

Pioneer Dj

DJ MIXER

DJM-900NXS2

<http://pioneerdj.com/support/>

The Pioneer DJ site shown above offers FAQs, information on software, and various other types of information and services to allow you to use your product in greater comfort.

<http://rekordbox.com/>

For various types of information and services regarding rekordbox™, see the Pioneer website above.

Operating Instructions (Quick Start Guide)

IMPORTANT



The lightning flash with arrowhead symbol, within an equilateral triangle, is intended to alert the user to the presence of uninsulated "dangerous voltage" within the product's enclosure that may be of sufficient magnitude to constitute a risk of electric shock to persons.

CAUTION

**RISK OF ELECTRIC SHOCK
DO NOT OPEN**

CAUTION:
TO PREVENT THE RISK OF ELECTRIC SHOCK, DO NOT REMOVE COVER (OR BACK). NO USER-SERVICEABLE PARTS INSIDE. REFER SERVICING TO QUALIFIED SERVICE PERSONNEL.



The exclamation point within an equilateral triangle is intended to alert the user to the presence of important operating and maintenance (servicing) instructions in the literature accompanying the appliance.

D3-4-2-1-1b_A1_En

IMPORTANT



Ce symbole de l'éclair, placé dans un triangle équilatéral, a pour but d'attirer l'attention de l'utilisateur sur la présence, à l'intérieur du coffret de l'appareil, de "tensions dangereuses" non isolées d'une grandeur suffisante pour représenter un risque d'électrocution pour les êtres humains.

ATTENTION

**DANGER D'ÉLECTROCUTION
NE PAS OUVRIR**

ATTENTION :
POUR ÉVITER TOUT RISQUE D'ÉLECTROCUTION, NE PAS ENLEVER LE COUVERCLE (NI LE PANNEAU ARRIÈRE). AUCUNE PIÈCE RÉPARABLE PAR L'UTILISATEUR NE SE TROUVE À L'INTÉRIEUR. CONFIER TOUT ENTRETIEN À UN PERSONNEL QUALIFIÉ UNIQUEMENT.



Ce point d'exclamation, placé dans un triangle équilatéral, a pour but d'attirer l'attention de l'utilisateur sur la présence, dans les documents qui accompagnent l'appareil, d'explications importantes du point de vue de l'exploitation ou de l'entretien.

D3-4-2-1-1b_A1_Fr

IMPORTANT SAFETY INSTRUCTIONS

- 1) Read these instructions.
- 2) Keep these instructions.
- 3) Heed all warnings.
- 4) Follow all instructions.
- 5) Do not use this apparatus near water.
- 6) Clean only with dry cloth.
- 7) Do not block any ventilation openings. Install in accordance with the manufacturer's instructions.
- 8) Do not install near any heat sources such as radiators, heat registers, stoves, or other apparatus (including amplifiers) that produce heat.
- 9) Do not defeat the safety purpose of the polarized or grounding-type plug. A polarized plug has two blades with one wider than the other. A grounding type plug has two blades and a third grounding prong. The wide blade or the third prong are provided for your safety. If the provided plug does not fit into your outlet, consult an electrician for replacement of the obsolete outlet.
- 10) Protect the power cord from being walked on or pinched particularly at plugs, convenience receptacles, and the point where they exit from the apparatus.
- 11) Only use attachments/accessories specified by the manufacturer.
- 12) Use only with the cart, stand, tripod, bracket, or table specified by the manufacturer, or sold with the apparatus. When a cart is used, use caution when moving the cart/apparatus combination to avoid injury from tip-over.
- 13) Unplug this apparatus during lightning storms or when unused for long periods of time.
- 14) Refer all servicing to qualified service personnel. Servicing is required when the apparatus has been damaged in any way, such as power-supply cord or plug is damaged, liquid has been spilled or objects have fallen into the apparatus, the apparatus has been exposed to rain or moisture, does not operate normally, or has been dropped.



D3-7-13-69_En

VENTILATION CAUTION

When installing this unit, make sure to leave space around the unit for ventilation to improve heat radiation (at least 5 cm at rear, and 3 cm at each side).

D3-4-2-1-7d*_A1_En

CAUTION

The **POWER** switch on this unit will not completely shut off all power from the AC outlet. Since the power cord serves as the main disconnect device for the unit, you will need to unplug it from the AC outlet to shut down all power. Therefore, make sure the unit has been installed so that the power cord can be easily unplugged from the AC outlet in case of an accident. To avoid fire hazard, the power cord should also be unplugged from the AC outlet when left unused for a long period of time (for example, when on vacation).

D3-4-2-2-2a*_A1_En

Operating Environment

Operating environment temperature and humidity: +5 °C to +35 °C (+41 °F to +95 °F); less than 85 %RH (cooling vents not blocked)

Do not install this unit in a poorly ventilated area, or in locations exposed to high humidity or direct sunlight (or strong artificial light).

D3-4-2-1-7c*_A2_En

WARNING

This equipment is not waterproof. To prevent a fire or shock hazard, do not place any container filled with liquid near this equipment (such as a vase or flower pot) or expose it to dripping, splashing, rain or moisture.

D3-4-2-1-3_A1_En

WARNING

This product equipped with a three-wire grounding (earthed) plug - a plug that has a third (grounding) pin. This plug only fits a grounding-type power outlet. If you are unable to insert the plug into an outlet, contact a licensed electrician to replace the outlet with a properly grounded one. Do not defeat the safety purpose of the grounding plug.

D3-4-2-1-6_A1_En

WARNING

To prevent a fire hazard, do not place any naked flame sources (such as a lighted candle) on the equipment.

D3-4-2-1-7a_A1_En

CAUTION

This product satisfies FCC regulations when shielded cables and connectors are used to connect the unit to other equipment. To prevent electromagnetic interference with electric appliances such as radios and televisions, use shielded cables and connectors for connections.

D8-10-3a_A1_En

PRÉCAUTION DE VENTILATION

Lors de l'installation de l'appareil, veuillez à laisser un espace suffisant autour de ses parois de manière à améliorer la dissipation de chaleur (au moins 5 cm à l'arrière et 3 cm de chaque côté).

D3-4-2-1-7d*_A1_Fr

ATTENTION

L'interrupteur **POWER** de cet appareil ne coupe pas complètement celui-ci de sa prise secteur. Comme le cordon d'alimentation fait office de dispositif de déconnexion du secteur, il devra être débranché au niveau de la prise secteur pour que l'appareil soit complètement hors tension. Par conséquent, veuillez à installer l'appareil de telle manière que son cordon d'alimentation puisse être facilement débranché de la prise secteur en cas d'accident. Pour éviter tout risque d'incendie, le cordon d'alimentation sera débranché au niveau de la prise secteur si vous prévoyez une période prolongée de non utilisation (par exemple avant un départ en vacances).

D3-4-2-2-2a*_A1_Fr

Milieu de fonctionnement

Température et humidité du milieu de fonctionnement : De +5 °C à +35 °C (de +41 °F à +95 °F) ; Humidité relative inférieure à 85 % (orifices de ventilation non obstrués)

N'installez pas l'appareil dans un endroit mal ventilé ou un lieu soumis à une forte humidité ou en plein soleil (ou à une forte lumière artificielle).

D3-4-2-1-7c*_A1_Fr

AVERTISSEMENT

Cet appareil n'est pas étanche. Pour éviter les risques d'incendie et de décharge électrique, ne placez près de lui un récipient rempli d'eau, tel qu'un vase ou un pot de fleurs, et ne l'exposez pas à des gouttes d'eau, des éclaboussures, de la pluie ou de l'humidité.

D3-4-2-1-3_A1_Fr

AVERTISSEMENT

Cet appareil est muni d'une fiche de mise à la terre (masse) à trois fils. Comme la fiche présente une troisième broche (de terre), elle ne peut se brancher que sur une prise de courant, prévue pour une mise à la terre. Si vous n'arrivez pas à insérer la fiche dans la prise de courant, contactez un électricien qualifié pour faire remplacer la prise par une qui soit mise à la terre. N'annulez pas la fonction de sécurité que procure cette fiche de mise à la terre.

D3-4-2-1-6_A1_Fr

AVERTISSEMENT

Pour éviter les risques d'incendie, ne placez aucune flamme nue (telle qu'une bougie allumée) sur l'appareil.

D3-4-2-1-7a_A1_Fr

NOTE:

This equipment has been tested and found to comply with the limits for a Class B digital device, pursuant to Part 15 of the FCC Rules. These limits are designed to provide reasonable protection against harmful interference in a residential installation. This equipment generates, uses, and can radiate radio frequency energy and, if not installed and used in accordance with the instructions, may cause harmful interference to radio communications. However, there is no guarantee that interference will not occur in a particular installation. If this equipment does cause harmful interference to radio or television reception, which can be determined by turning the equipment off and on, the user is encouraged to try to correct the interference by one or more of the following measures:

- Reorient or relocate the receiving antenna.
- Increase the separation between the equipment and receiver.
- Connect the equipment into an outlet on a circuit different from that to which the receiver is connected.
- Consult the dealer or an experienced radio/TV technician for help.

D8-10-1-2_A1_En

IMPORTANT NOTICE

THE MODEL NUMBER AND SERIAL NUMBER OF THIS EQUIPMENT ARE ON THE RIGHT SIDE. RECORD THESE NUMBERS ON PAGE 15 FOR FUTURE REFERENCE.

D36-AP9-3*_A1_En

Information to User

Alterations or modifications carried out without appropriate authorization may invalidate the user's right to operate the equipment.

D8-10-2_A1_En

WARNING: This product contains chemicals known to the State of California and other governmental entities to cause cancer and birth defects or other reproductive harm.

Wash hands after handling.

D36-P5_C1_En

POWER-CORD CAUTION

Handle the power cord by the plug. Do not pull out the plug by tugging the cord and never touch the power cord when your hands are wet as this could cause a short circuit or electric shock. Do not place the unit, a piece of furniture, etc., on the power cord, or pinch the cord. Never make a knot in the cord or tie it with other cords. The power cords should be routed such that they are not likely to be stepped on. A damaged power cord can cause a fire or give you an electrical shock. Check the power cord once in a while. When you find it damaged, ask your nearest service center or your dealer for a replacement.

S002*_A1_En

WARNING

Store small parts out of the reach of children and infants. If accidentally swallowed, contact a doctor immediately.

D41-6-4_A1_En

The Safety of Your Ears is in Your Hands

Get the most out of your equipment by playing it at a safe level – a level that lets the sound come through clearly without annoying blaring or distortion and, most importantly, without affecting your sensitive hearing. Sound can be deceiving. Over time, your hearing “comfort level” adapts to higher volumes of sound, so what sounds “normal” can actually be loud and harmful to your hearing. Guard against this by setting your equipment at a safe level BEFORE your hearing adapts.

ESTABLISH A SAFE LEVEL:

- Set your volume control at a low setting.
- Slowly increase the sound until you can hear it comfortably and clearly, without distortion.
- Once you have established a comfortable sound level, set the dial and leave it there.

BE SURE TO OBSERVE THE FOLLOWING GUIDELINES:

- Do not turn up the volume so high that you can't hear what's around you.
- Use caution or temporarily discontinue use in potentially hazardous situations.
- Do not use headphones while operating a motorized vehicle; the use of headphones may create a traffic hazard and is illegal in many areas.

S001a_A1_En

FEDERAL COMMUNICATIONS COMMISSION DECLARATION OF CONFORMITY

This device complies with part 15 of the FCC Rules. Operation is subject to the following two conditions: (1) This device may not cause harmful interference, and (2) this device must accept any interference received, including interference that may cause undesired operation.

Product Name: DJ MIXER

Model Number: DJM-900NXS2

Responsible Party Name: PIONEER ELECTRONICS (USA) INC.
SERVICE SUPPORT DIVISION

Address: 1925 E. DOMINGUEZ ST. LONG BEACH, CA 90810-1003, U.S.A.

Phone: 1-800-421-1404

URL: <http://www.pioneerelectronics.com>

D8-10-4*_C1_En

Contents

How to read this manual

Thank you for buying this Pioneer DJ product.

Be sure to read this manual and the Operating Instructions that is available on the Pioneer DJ site. Both contain important information that you should understand before using this product.

In particular, be sure to read "IMPORTANT SAFETY INSTRUCTIONS." Furthermore, be sure to keep this manual together with "Warranty" on the last pages.

- In this manual, names of channels and buttons indicated on the product, names of menus in the software, etc., are indicated within square brackets ([]). (e.g. [MASTER] channel, [ON/OFF], [File] menu)
- Please note that the screens and specifications of the software described in this manual as well as the external appearance and specifications of the hardware are currently under development and may differ from the final specifications.
- Please note that depending on the operating system version, web browser settings, etc., operation may differ from the procedures described in this manual.

This manual provides brief descriptions regarding the names of parts of this unit and the connections between this unit and peripherals.

For more detailed instructions on using this unit, see the Operating Instructions for this unit.

- For how to obtain the Operating Instructions for this unit, see *Acquiring this unit's Operating Instructions* on page 6.

01 Before start

Features	6
What's in the box	6
Acquiring this unit's Operating Instructions	6
Preparing the software.....	6

02 Part names and functions

Rear panel	7
Control Panel	8

03 Connections

Connecting input terminals.....	10
Connecting output terminals	11
Connecting to the control panel.....	11

04 Operation

Basic Operation	12
-----------------------	----

05 Additional information

Troubleshooting	13
Changing the settings.....	13
About trademarks and registered trademarks	13
Cautions on copyrights	13
Specifications.....	14

Before start

Features

This unit is a mixer for professional DJ players that carries on the tradition of the Pioneer DJM series, which has become a world standard in the disco and club scene. It is not only equipped with a wide range of features for DJ performances, including SOUND COLOR FX, BEAT FX, and PRO DJ LINK, but it also has a design that facilitates high-quality sound and high reliability design as well as a panel layout providing excellent operability, thereby offering strong support for all types of DJ performances.

What's in the box

- Power cord
- USB cable
 - Only one USB cable is included with this unit.
To connect two units, use a cable conforming to USB 2.0 standards.
- Operating Instructions (Quick Start Guide) (This document)

Acquiring this unit's Operating Instructions

Various instructions are sometimes provided as files in PDF format. Adobe® Reader® must be installed in order to view PDF format files.

- 1 Launch a web browser on the computer and access the Pioneer DJ site below.**
<http://www.pioneerdj.com/>
- 2 Click [Support].**
- 3 Click the [FIND TUTORIALS & MANUALS] icon.**
- 4 Click the [DJM-900NXS2] icon in the [Mixer] category.**
- 5 Click on the required language on the download page.**

Preparing the software

About the driver software

This driver software is an exclusive driver for outputting audio signals from a computer.

❖ Obtaining the driver software

- 1 Launch a web browser on the computer and access the Pioneer DJ site below.**
<http://www.pioneerdj.com/>
- 2 Click the [Support] icon.**
- 3 Click the [FIND SOFTWARE & FIRMWARE UPDATES] icon.**
- 4 Click the [DJM-900NXS2] icon in the [Mixer] category.**
- 5 After clicking [Drivers], download the latest driver software from the download page.**

Part names and functions

Rear panel

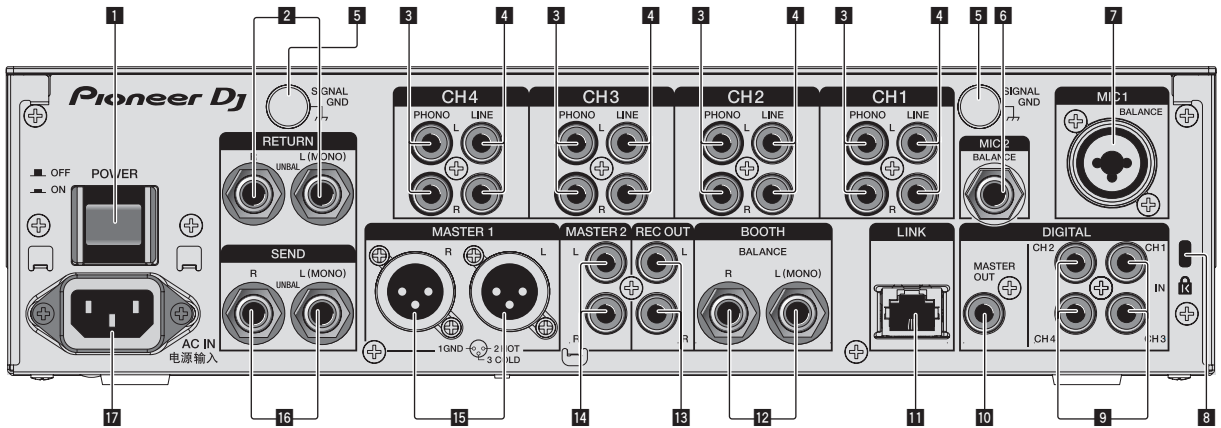

1 POWER button (page 12)

Turns this unit's power on and off.

2 RETURN terminals (page 11)

Connect to the output terminal of an external effector. When the [L (MONO)] channel only is connected, the [L (MONO)] channel input is simultaneously input to the [R] channel.

3 PHONO terminals (page 10)

Connect to a phono level (MM cartridge) output device. Do not input line level signals.

To connect a device to the [PHONO] terminals, remove the short-circuit pin plug inserted in the terminals.

Insert this short-circuit pin plug into the [PHONO] terminals when nothing is connected to them to cut external noise.

4 LINE terminals (page 10)

Connect to a DJ player or a line level output component.

5 SIGNAL GND terminal (page 10)

Connects an analog player's ground wire here. This helps reduce noise when the analog player is connected.

6 MIC2 terminal (page 10)

Connects a microphone here.

7 MIC1 terminal (page 10)

Connects a microphone here.

8 Kensington security slot

9 DIGITAL IN terminal (page 10)

Connect these to the digital coaxial output terminals on DJ players, etc. The sound may be momentarily interrupted when the output signal sampling frequency is switched.

10 DIGITAL MASTER OUT terminal (page 11)

Connect this to the digital terminal of a preamplifier, etc. It outputs the master channel audio in SPDIF format. **Take careful not to connect it to an analog input terminal by mistake.**

11 LINK terminal (page 10)

Connect this to the LINK terminals of a Pioneer DJ player or the LAN ports of a computer with rekordbox installed (PRO DJ LINK).

To connect multiple devices, use a switching hub (commercially available).

Use a 100Base-TX-compatible switching hub. Some switching hubs may not operate properly.

12 BOOTH terminals (page 11)

These are output terminals for a booth monitor.

When only [L (MONO)] is connected, monaural audio is output.

13 REC OUT terminals (page 11)

These are output terminals for recording.

14 MASTER2 terminals (page 11)

Connect these to the analog input terminals of a power amplifier, etc.

15 MASTER1 terminals (page 11)

Connect these to the analog input terminals of a power amplifier, etc. Be sure to use these as balanced outputs. **Be careful not to accidentally insert the power cord of another unit.**

16 SEND terminals (page 11)

Connect to the input terminal of an external effector. When the [L (MONO)] channel only is connected, a monaural audio signal is output.

17 AC IN

Connects to a power outlet using the included power cord. Wait until all connections between the equipment are completed before connecting the power cord.

Be sure to use the included power cord.

WARNING

The short-circuit pin plugs out of the reach of children and infants. If accidentally swallowed, contact a doctor immediately.

Control Panel

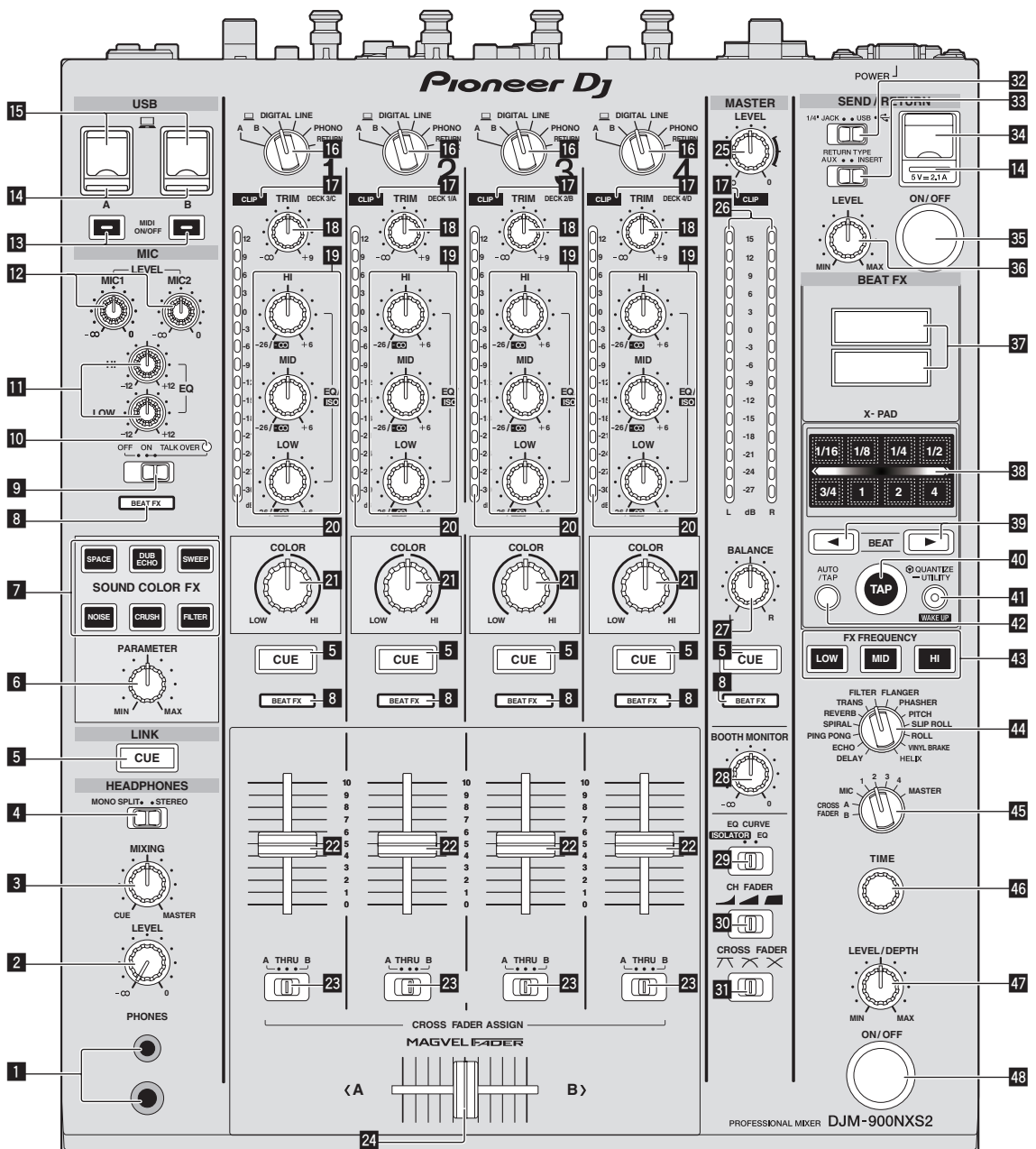

1 PHONES terminal (page 12)

Connect headphones here.
This product supports 1/4" stereo phone plugs and 3.5 mm stereo mini plugs.

2 LEVEL control (page 12)

Adjusts the sound level output from the headphones.

3 MIXING control (page 12)

This adjusts the monitor volume balance of the sound of channels for which the [CUE] button is pressed and the sound of the [MASTER] channel.

4 MONO SPLIT, STEREO selector switch (page 12)

Switches how the monitor sound output from the headphones is distributed.

5 CUE button (page 12)

Presses the [CUE] button(s) for the channel(s) you want to monitor.

6 PARAMETER control

Adjusts the SOUND COLOR FX parameter.

7 SOUND COLOR FX buttons

These turn the SOUND COLOR FX effects on/off.

8 Effect channel selector indicator

The indicator of the channel selected with the effect channel selector switch lights.

9 OFF, ON, TALK OVER selector switch (page 12)

Turns the microphone on/off.

10 Microphone indicator (page 12)

- 11 EQ (HI, LOW) controls (page 12)**
These adjust the tone quality of the [MIC1] and [MIC2] channels.
- 12 MIC LEVEL control (page 12)**
Adjusts the level of the sound output from the [MIC1] channel or [MIC2] channel.
- 13 MIDI ON/OFF buttons**
Switches the MIDI function on and off.
- 14 USB connection indicator**
An indicator lights when a computer is connected. It flashes when the driver software is not installed on the computer.
- 15 USB terminal (page 11)**
Connect the computer.
- 16 Input selector switches (page 12)**
Selects the input source of each channel from the components connected to this unit.
- 17 CLIP indicators**
An indicator lights when sound with an excessively high volume is input to a channel.
- 18 TRIM control (page 12)**
Adjusts the level of audio signals input in each channel.
- 19 EQ/ISO (HI, MID, LOW) controls**
These adjust the sound quality of the respective channels.
- 20 Channel Level Indicator (page 12)**
Displays the sound level of the respective channels before passing through the channel faders.
- 21 COLOR control**
This changes the parameters of the SOUND COLOR FX of the different channels.
- 22 Channel Fader (page 12)**
Adjusts the level of audio signals output in each channel.
- 23 CROSS FADER ASSIGN (A, THRU, B) selector switch (page 12)**
Sets the output destination of each channel to [A] or [B].
- 24 Crossfader (page 12)**
Outputs audio signals assigned by the crossfader assign switch corresponding to the curve characteristics selected by [CROSS FADER] (Crossfader Curve Selector Switch).
- 25 MASTER LEVEL control (page 12)**
Adjusts the audio level output from the [MASTER1] and [MASTER2] terminals.
- 26 Master Level Indicator (page 12)**
Displays the audio level output from the [MASTER1] and [MASTER2] terminals.
- 27 BALANCE control**
Adjusts the left/right balance of the sound output from the [MASTER1] terminals, etc.
- 28 BOOTH MONITOR control (page 12)**
Adjusts the level of audio signals output from the [BOOTH] terminal.
- 29 EQ CURVE (ISOLATOR, EQ) selector switch**
Switches the function of the [EQ/ISO (HI, MID, LOW)] controls.
- 30 CH FADER () selector switch**
Switches the channel fader's curve characteristics.
- 31 CROSS FADER () selector switch**
This switches the crossfader curve characteristics.
- 32 SEND/RETURN (1/4" JACK, ) selector switch**
Switches the I/O source of the SEND/RETURN channel.
This selects either the device connected to the [SEND/RETURN] terminals on the back of the unit or the device connected to the mobile device connection terminal on the operation panel.
- 33 RETURN TYPE (AUX, INSERT) selector switch**
Selects the SEND/RETURN method.
- 34 Mobile device connection terminal (USB port)**
Connect a mobile device.
- 35 SEND/RETURN ON/OFF button**
Turns SEND/RETURN on and off.
- 36 SEND/RETURN LEVEL control**
Adjusts the sound level of SEND/RETURN.
- 37 Main unit display**
Displays the effect name, BPM, effect parameter, etc.
- 38 X-PAD**
BEAT FX is on while this is touched. Also, the parameter can be adjusted depending on the place touched.
- 39 BEAT ◀, ▶ buttons**
Set the beat fraction for synchronizing the effect sound.
- 40 TAP button**
When the BPM measurement mode is set to [TAP], tap the button with a finger to input the BPM manually.
- 41 QUANTIZE (UTILITY, WAKE UP) button**
— **QUANTIZE**: When the QUANTIZE function is turned on for BEAT FX, the effect is applied to the sound without getting out of tempo with the currently playing track.
— **UTILITY**: Displays the [UTILITY] screen.
— **WAKE UP**: Cancels the standby state.
- 42 AUTO/TAP button**
Switches the BPM measurement mode.
- 43 FX FREQUENCY button**
Select the range to apply BEAT FX. BEAT FX is applied to the range of the button that is lit.
- 44 Beat effect selector switch**
Switches the BEAT FX effect type.
- 45 Effect channel selector switch**
Switches the channel to which the BEAT FX is to be applied.
- 46 TIME control**
Adjusts the BEAT FX's time parameter.
- 47 LEVEL/DEPTH control**
Adjusts the BEAT FX's quantitative parameter.
- 48 Beat effect ON/OFF button**
Turns BEAT FX on and off.

Do not pull on the channel fader and crossfader knobs with excessive force. The knobs have a structure by which they cannot be pulled off easily. Pulling the knobs strongly may result in damaging the unit.

Connections

Be sure to turn off the power and unplug the power cord from the power outlet whenever making or changing connections. Connect the power cord after all the connections between devices have been completed. Be sure to use the included power cord. Refer to the operating instructions for the component to be connected.

- When connecting using a LAN cable, use an STP (CAT5e shielded) cable.
- Do not disconnect the LAN cable when music files and/or information are being shared using PRO DJ LINK.

Connecting input terminals

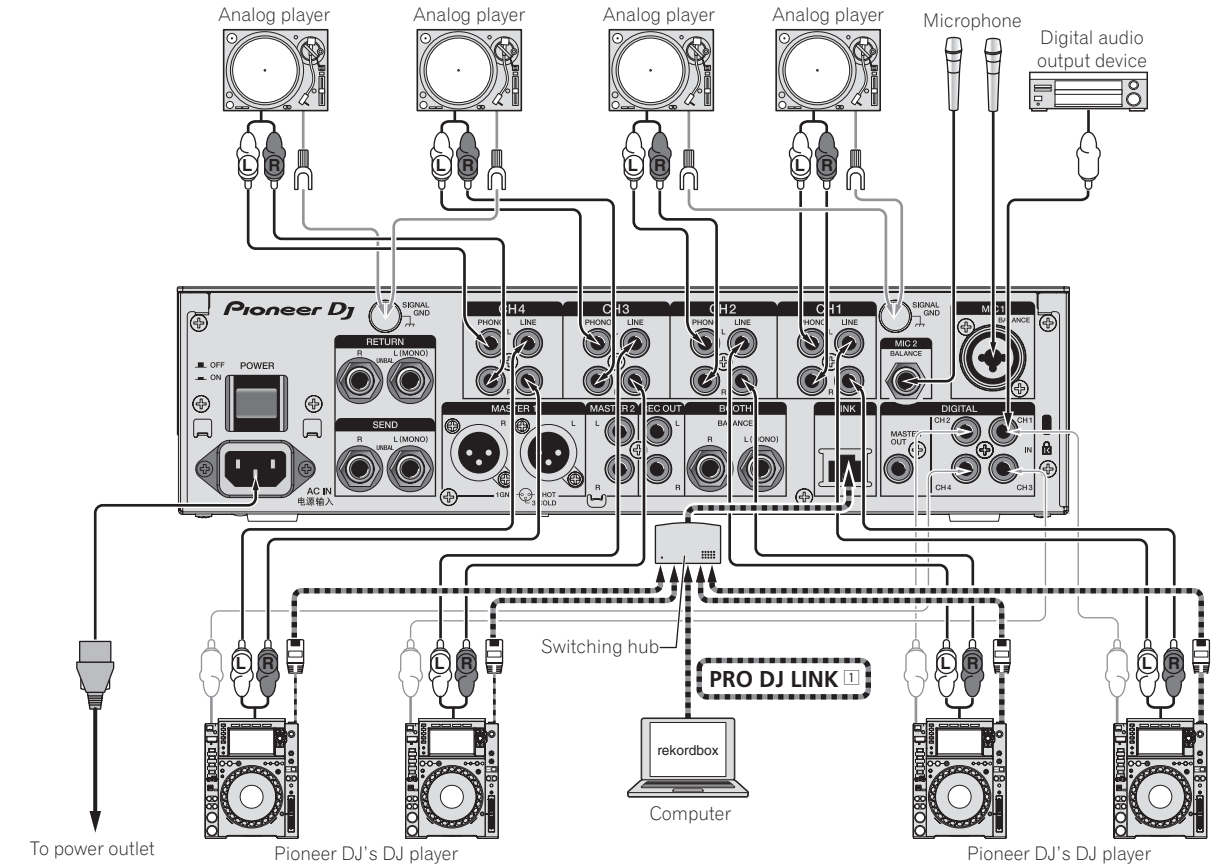

1 For details on PRO DJ LINK, see the Operating Instructions.

Connecting output terminals

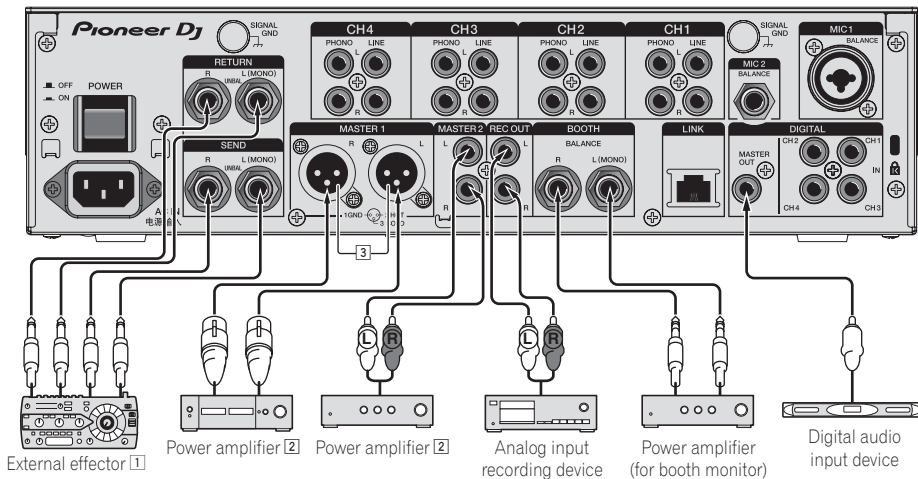

- 1 Also connect the external effector to the [RETURN] terminal (input terminal).
- 2 Be sure to use the [MASTER1] terminals only for a balanced output. Connection with an unbalanced input (such as RCA) using an XLR to RCA converter cable (or converter adapter), etc., may lower the sound quality and/or result in noise. For connection with an unbalanced input (such as RCA), use the [MASTER2] terminals.
- 3 **Be careful not to accidentally insert the power cord of another unit to [MASTER1] terminal.**

Connecting to the control panel

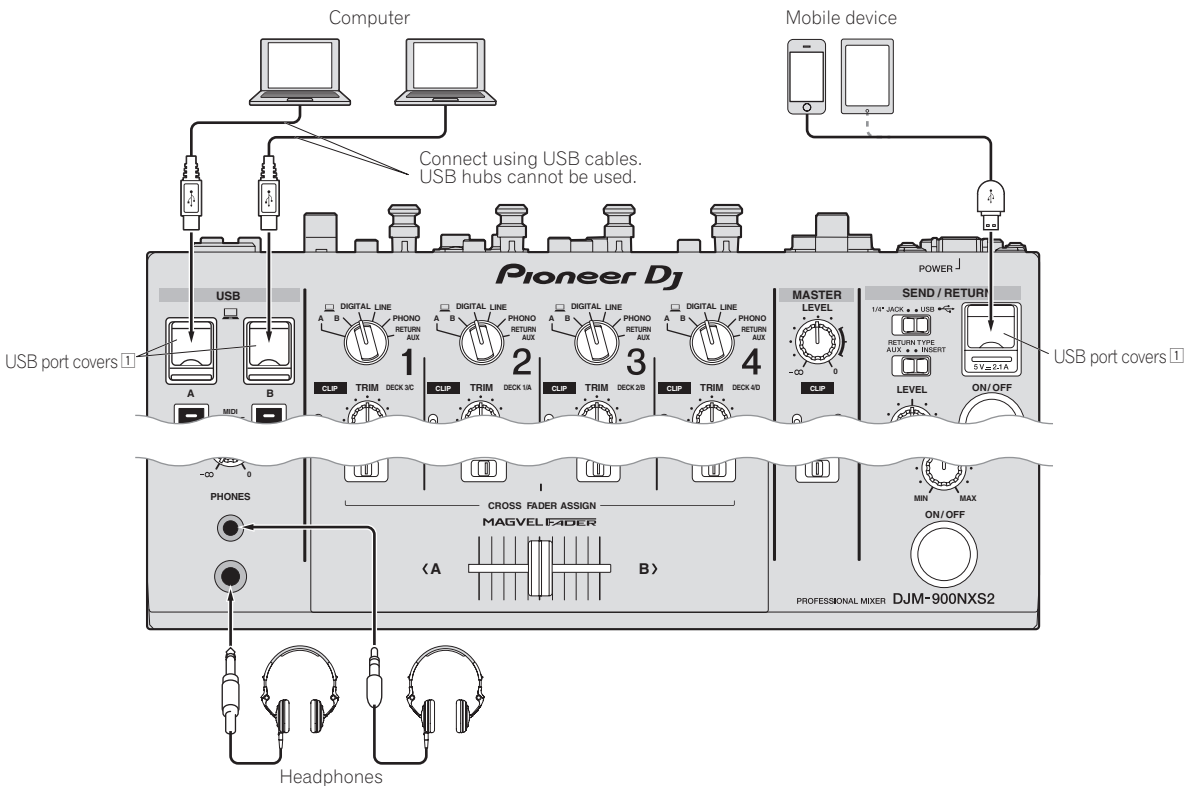

- 1 Do not push or pull hard on a USB port cover. It could be damaged.

Operation

Basic Operation

Outputting sound

1 Press [POWER] button.

Turn on the power of this unit.

2 Switch the input selector switches.

Selects the input sources for the different channels from among the devices connected to this unit.

3 Turn the [TRIM] control.

Adjusts the level of audio signals input in each channel. The corresponding channel level indicator lights when audio signals are being properly input to that channel.

4 Move the channel fader away from you.

Adjusts the level of audio signals output in each channel.

5 Switch the [CROSS FADER ASSIGN (A, THRU, B)] selector switch.

Switches the output destination of each channel.

6 Set the crossfader.

This operation is not necessary when the [CROSS FADER ASSIGN (A, THRU, B)] selector switch is set to [THRU].

7 Turn the [MASTER LEVEL] control.

Audio signals are output from the [MASTER1] and [MASTER2] terminals. The master level indicator lights.

Monitoring sound with headphones

1 Connect headphones to the [PHONES] terminal.

2 Press the [CUE] button(s) for the channel(s) you want to monitor.

3 Switch the [MONO SPLIT, STEREO] selector switch.

4 Turn the [MIXING] control.

This adjusts the monitor volume balance of the sound of channels for which the [CUE] button is pressed and the sound of the [MASTER] channel.

5 Turn the [LEVEL] control for [HEADPHONES].

The sound of the channels for which the [CUE] button is pressed is output from the headphones.

- When the [CUE] button is pressed again, monitoring is canceled.
-

Using a microphone

1 Connect a microphone to the [MIC1] or [MIC2] terminal.

2 Set the [OFF, ON, TALK OVER] selector switch to [ON] or [TALK OVER].

- When set to [TALK OVER], the sound of channels other than the [MIC] channel is attenuated by 18 dB (default) when a sound of -10 dB or greater is input to the microphone.
- The sound attenuation level of [TALK OVER] can be changed with [UTILITY]. For details on how to change the level, see the Operating Instructions.
- The TALK OVER mode can be switched to normal mode or advanced mode. For details on how to change the mode, see the Operating Instructions.

3 Turn the [MIC1 LEVEL] or [MIC2 LEVEL] control.

Adjust the level of the sound output from the [MIC] channel.

- Pay attention that rotating to the extreme right position outputs a very loud sound.

4 Input audio signals to the microphone.

Audio is output from the [BOOTH] terminal

Turn the [BOOTH MONITOR] control.

Adjusts the level of audio signals output from the [BOOTH] terminal.

Additional information

Troubleshooting

- If you think that there is something wrong with this unit, check the following items, and also access [FAQ & DJ software support information] on the Pioneer DJ support site and check [FAQ] for [DJM-900NXS2]. Sometimes the problem may lie in another component. Inspect the other components and electrical appliances being used. If the problem cannot be rectified, ask your nearest Pioneer authorized service center or your dealer to carry out repair work.
<http://pioneerdj.com/support/>
- This unit may not operate properly due to static electricity or other external influences. In such cases, normal operation may be restored by unplugging the power cord then plugging it back in.

Problem	Check	Remedy
The power is not turned on.	Is the power cord properly connected?	Plug in the power cord to an AC outlet.
No sound or small sound.	Is the input selector switch set to the proper position?	Switch the input selector switch to switch the channel's input source. (page 12)
	Are the connection cables properly connected?	Connect the connection cables properly. (page 10)
	Are the terminals and plugs dirty?	Clean the terminals and plugs before making connections.
Distorted sound.	Is the sound level output from the [MASTER] channel appropriately set?	Adjust the [MASTER LEVEL] control so that the master channel level indicator lights at around [0 dB] at the peak level. (page 12)
	Is the level of audio input to each channel properly set?	Adjust the [TRIM] control so that the channel level indicator lights at about [0 dB] at the peak level. (page 12)
Can't crossfade.	Are the [CROSS FADER ASSIGN (A, THRU, B)] selector switches properly set?	Set the [CROSS FADER ASSIGN (A, THRU, B)] selector switches for the different channels properly. (page 12)
Sound is distorted when an analog player is connected to this unit's [PHONO] terminals. Or, lighting of the channel level indicator does not change even when the [TRIM] control is turned.	Have you connected an analog player with a built-in phono equalizer?	Connect the analog player with built-in phono equalizer to the [LINE] terminals. (page 10) If the analog player with built-in phono equalizer has a PHONO/LINE selector switch, switch it to PHONO.
	Is an audio interface for computers connected between the analog player and this unit?	If the output of the audio interface for computers is line level, connect it to the [LINE] terminals. (page 10) If the analog player has a PHONO/LINE selector switch, switch it to PHONO.

Changing the settings

- For details on how to change the settings of this unit, see "Changing the settings" in the Operating Instructions.

About trademarks and registered trademarks

- "Pioneer DJ" is a trademark of PIONEER CORPORATION, and is used under license.

The names of companies and products mentioned herein are trademarks or registered trademarks of their respective owners.

Cautions on copyrights

Recordings you have made are for your personal enjoyment and according to copyright laws may not be used without the consent of the copyright holder.

- Music recorded from CDs, etc., is protected by the copyright laws of individual countries and by international treaties. It is the full responsibility of the person who has recorded the music to ensure that it is used legally.
- When handling music downloaded from the Internet, etc., it is the full responsibility of the person who has downloaded the music to ensure that it is used in accordance with the contract concluded with the download site.

Specifications

General

Power requirements	AC 110 V to 240 V, 50 Hz/60 Hz
Power consumption	60 W
Power consumption (standby)	0.4 W
Main unit weight	8.0 kg (17.6 lb)
Max. dimensions	333 mm (W) × 107.9 mm (H) × 414.2 mm (D) (13.1 in. (W) × 4.2 in. (H) × 16.3 in. (D))
Tolerable operating temperature	+5 °C to +35 °C (+41 °F to +95 °F)
Tolerable operating humidity	5 % to 85 % (no condensation)

Audio Section

Sampling rate	96 kHz
MASTER D/A converter	32 bits
Other A/D and D/A converters	24 bits
Frequency characteristic	
LINE	20 Hz to 40 kHz
S/N ratio (rated output)	
PHONO	88 dB
LINE	105 dB
MIC1, MIC2	79 dB
Total harmonic distortion (LINE — MASTER1)	0.005 %
Standard input level / Input impedance	
PHONO	-52 dBu/47 kΩ
LINE	-12 dBu/47 kΩ
MIC1, MIC2	-52 dBu/8 kΩ
RETURN	-12 dBu/47 kΩ
Standard output level / Load impedance / Output impedance	
MASTER1	+6 dBu/10 kΩ/100 Ω or lower
MASTER2	+2 dBu/10 kΩ/390 Ω or lower
REC OUT	-8 dBu/10 kΩ/22 Ω or lower
BOOTH	+6 dBu/10 kΩ/100 Ω or lower
SEND	-12 dBu/10 kΩ/1 kΩ or lower
PHONES	+8.5 dBu/32 Ω/1 Ω or lower
Rated output level / Load impedance	
MASTER1	+25 dBu/10 kΩ
MASTER2	+21 dBu/10 kΩ
Crosstalk (LINE)	82 dB
Channel equalizer characteristic	
HI	-26 dB to +6 dB (30 kHz)
MID	-26 dB to +6 dB (1 kHz)
LOW	-26 dB to +6 dB (20 Hz)
Microphone equalizer characteristic	
HI	-12 dB to +12 dB (10 kHz)
LOW	-12 dB to +12 dB (100 Hz)

Input / Output terminals

PHONO input terminal	
RCA pin jacks	4 sets
LINE input terminal	
RCA pin jacks	4 sets
MIC1 input terminal (XLR/TRS)	
XLR connector & 1/4" TRS jack	1 set
MIC2 input terminal (TRS)	
1/4" TRS jack	1 set
RETURN Input terminals (TS)	
1/4" TS jack	1 set
DIGITAL IN coaxial input terminal	
RCA pin jacks	4 sets
MASTER output terminal	
XLR connector	1 set
RCA pin jacks	1 set
BOOTH output terminal (TRS)	
1/4" TRS jack	1 set
REC OUT output terminal	
RCA pin jacks	1 set
SEND output terminal (TS)	
1/4" TS jack	1 set
DIGITAL MASTER OUT coaxial output terminal	
RCA pin jacks	1 set

PHONES output terminal	
1/4" stereo phone jack	1 set
3.5 mm stereo mini jack	1 set
USB terminal	
Type A	1 set
Power supply	5 V/2.1 A or less
B type	2 sets
LINK terminal	
LAN terminal (100Base-TX)	1 set
• The specifications and design of this product are subject to change without notice.	
• © 2015 Pioneer DJ Corporation. All rights reserved.	

Pioneer Dj

Pioneer DJ Americas, Inc.
LIMITED WARRANTY
WARRANTY VALID ONLY IN THE U.S.A. AND CANADA

WARRANTY

Pioneer DJ Americas, Inc. (PDJA) warrants that products distributed by PDJA in the U.S.A. and Canada that fail to function properly under normal use due to a manufacturing defect when installed and operated according to the owner's manual enclosed with the unit will be repaired or replaced with a unit of comparable value, at the option of PDJA, without charge to you for parts or actual repair work. Parts supplied under this warranty may be new or rebuilt at the option of PDJA.

THIS LIMITED WARRANTY APPLIES TO THE ORIGINAL OR ANY SUBSEQUENT OWNER OF THIS PIONEER DJ PRODUCT DURING THE WARRANTY PERIOD PROVIDED THE PRODUCT WAS PURCHASED FROM AN AUTHORIZED PIONEER DJ DISTRIBUTOR/DEALER IN THE U.S.A. OR CANADA. YOU WILL BE REQUIRED TO PROVIDE A SALES RECEIPT OR OTHER VALID PROOF OF PURCHASE SHOWING THE DATE OF ORIGINAL PURCHASE OR, IF RENTED, YOUR RENTAL CONTRACT SHOWING THE PLACE AND DATE OF FIRST RENTAL. IN THE EVENT SERVICE IS REQUIRED, THE PRODUCT MUST BE DELIVERED WITHIN THE WARRANTY PERIOD, TRANSPORTATION PREPAID, ONLY FROM WITHIN THE U.S.A. AS EXPLAINED IN THIS DOCUMENT. YOU WILL BE RESPONSIBLE FOR REMOVAL AND INSTALLATION OF THE PRODUCT. PDJA WILL PAY TO RETURN THE REPAIRED OR REPLACEMENT PRODUCT TO YOU WITHIN THE U.S.A.

PRODUCT WARRANTY PERIOD

DJ Audio and Video

Parts Labor

1 Year 1 Year

The warranty period for retail customers who rent the product commences upon the date product is first put into use (a) during the rental period or (b) retail sale, whichever occurs first.

WHAT IS NOT COVERED

IF THIS PRODUCT WAS PURCHASED FROM AN UNAUTHORIZED DISTRIBUTOR, THERE ARE NO WARRANTIES, EXPRESS OR IMPLIED, INCLUDING THE IMPLIED WARRANTY OF MERCHANTABILITY AND THE IMPLIED WARRANTY OF FITNESS FOR A PARTICULAR PURPOSE AND THIS PRODUCT IS SOLD STRICTLY "AS IS" AND "WITH ALL FAULTS".

PIONEER DJ SHALL NOT BE LIABLE FOR ANY CONSEQUENTIAL AND/OR INCIDENTAL DAMAGES.

THIS WARRANTY DOES NOT APPLY IF THE PRODUCT HAS BEEN SUBJECTED TO POWER IN EXCESS OF ITS PUBLISHED POWER RATING.

THIS WARRANTY DOES NOT COVER THE CABINET OR ANY APPEARANCE ITEM, USER ATTACHED ANTENNA, ANY DAMAGE TO RECORDS OR RECORDING TAPES OR DISCS, ANY DAMAGE TO THE PRODUCT RESULTING FROM ALTERATIONS, MODIFICATIONS NOT AUTHORIZED IN WRITING BY PIONEER DJ, ACCIDENT, MISUSE OR ABUSE, DAMAGE DUE TO LIGHTNING OR TO POWER SURGES, SUBSEQUENT DAMAGE FROM LEAKING, DAMAGE FROM INOPERATIVE BATTERIES, OR THE USE OF BATTERIES NOT CONFORMING TO THOSE SPECIFIED IN THE OWNER'S MANUAL.

THIS WARRANTY DOES NOT COVER THE COST OF PARTS OR LABOR WHICH WOULD BE OTHERWISE PROVIDED WITHOUT CHARGE UNDER THIS WARRANTY OBTAINED FROM ANY SOURCE OTHER THAN A PIONEER DJ AUTHORIZED SERVICE COMPANY OR OTHER DESIGNATED LOCATION. THIS WARRANTY DOES NOT COVER DEFECTS OR DAMAGE CAUSED BY THE USE OF UNAUTHORIZED PARTS OR LABOR OR FROM IMPROPER MAINTENANCE.

ALTERED, DEFACED, OR REMOVED SERIAL NUMBERS VOID THIS ENTIRE WARRANTY

NO OTHER WARRANTIES

PIONEER DJ LIMITS ITS OBLIGATIONS UNDER ANY IMPLIED WARRANTIES INCLUDING, BUT NOT LIMITED TO, THE IMPLIED WARRANTIES OF MERCHANTABILITY AND FITNESS FOR A PARTICULAR PURPOSE, TO A PERIOD NOT TO EXCEED THE WARRANTY PERIOD. NO WARRANTIES SHALL APPLY AFTER THE WARRANTY PERIOD. SOME STATES DO NOT ALLOW LIMITATIONS ON HOW LONG AN IMPLIED WARRANTY LASTS AND SOME STATES DO NOT ALLOW THE EXCLUSIONS OR LIMITATIONS OF INCIDENTAL OR CONSEQUENTIAL DAMAGES, SO THE ABOVE LIMITATIONS OR EXCLUSIONS MAY NOT APPLY TO YOU. THIS WARRANTY GIVES YOU SPECIFIC LEGAL RIGHTS AND YOU MAY HAVE OTHER RIGHTS WHICH MAY VARY FROM STATE TO STATE.

TO OBTAIN SERVICE

PDJA has appointed a number of Authorized Service Companies throughout the U.S.A. and Canada should your product require service. To receive warranty service you need to present your sales receipt or, if rented, your rental contract showing place and date of original owner's transaction. If shipping the unit you will need to package it carefully and send it, transportation prepaid by a traceable, insured method, to an Authorized Service Company. Package the product using adequate padding material to prevent damage in transit. The original container is ideal for this purpose. Include your name, address and telephone number where you can be reached during business hours.

On all complaints and concerns in the U.S.A. and Canada call Customer Support at 1-800-872-4159.

For hook-up and operation of your unit or to locate an
Authorized Service Company, please call or write:
CUSTOMER SUPPORT
Pioneer DJ Americas, Inc.
P.O. BOX 1720
LONG BEACH, CALIFORNIA 90801
1-800-872-4159
<http://www.pioneerelectronics.com>

DISPUTE RESOLUTION

Following our response to any initial request to Customer Support, should a dispute arise between you and Pioneer DJ, Pioneer DJ makes available its Complaint Resolution Program to resolve the dispute. The Complaint Resolution Program is available to you without charge. You are required to use the Complaint Resolution Program before you exercise any rights under, or seek any remedies, created by Title I of the Magnuson-Moss Warranty-Federal Trade Commission Improvement Act, 15 U.S.C. 2301 *et seq.*

To use the Complaint Resolution Program call 1-800-872-4159 and explain to the customer service representative the problem you are experiencing, steps you have taken to have the product repaired during the warranty period and the name of the authorized Distributor/Dealer from whom the Pioneer DJ product was purchased. After the complaint has been explained to the representative, a resolution number will be issued. Within 40 days of receiving your complaint, Pioneer DJ will investigate the dispute and will either: (1) respond to your complaint in writing informing you what action Pioneer DJ will take, and in what time period, to resolve the dispute; or (2) respond to your complaint in writing informing you why it will not take any action.

RECORD THE PLACE AND DATE OF PURCHASE FOR FUTURE REFERENCE

Model No. _____ Serial No. _____ Purchase Date _____

Purchased From _____

KEEP THIS INFORMATION AND YOUR SALES RECEIPT IN A SAFE PLACE

UCP0515

To register your product, find the nearest authorized service location, to purchase replacement parts, operating instructions, or accessories, please go to one of following URLs :

Pour enregistrer votre produit, trouver le service après-vente agréé le plus proche et pour acheter des pièces de rechange, des modes d'emploi ou des accessoires, reportez-vous aux URL suivantes :

In the USA/Aux Etats-Unis or In Canada/Aux Canada
<http://www.pioneerelectronics.com>

S018_C1_EnFr_PSV

© 2015 Pioneer DJ Corporation.
All rights reserved.

Pioneer DJ Corporation

1-1, Shin-ogura, Saiwai-ku, Kawasaki-shi, Kanagawa 212-0031, Japan

Pioneer DJ 株式会社

〒212-0031 神奈川県川崎市幸区新小倉1番1号

Корпорация Пайонир Диджей

1-1, Син-Огура, Сайвай-ку, г. Кавасаки, префектура Канагава, 212-0031, Япония

Pioneer DJ Europe Limited

Anteros Building, Odyssey Business Park, West End Road, South Ruislip, Middlesex, HA4 6QQ, U.K. TEL: 44-203-7617-220

Pioneer DJ Americas, Inc.

P.O. BOX 1720, Long Beach, California 90801-1720, U.S.A. TEL: (800) 421-1404

PIONEER ELECTRONICS ASIACENTRE, PTE. LTD.

253 Alexandra Road, #04-01, Singapore 159936 TEL: 65-6472-7555

PIONEER ELECTRONICS AUSTRALIA PTY. LTD.

5 Arco Lane, Heatherton, Victoria, 3202, Australia, TEL: (03) 9586-6300

PIONEER ELECTRONICS (THAILAND) CO., LTD.

17th Fl., KPN Tower, 719 Rama 9 Road, Bangkapi, Huaykwang, Bangkok 10310
TEL: 66-2-717-0777

PIONEER TECHNOLOGY (MALAYSIA) SDN. BHD

16th Floor, Menara Uni. Asia 1008 Jalan Sultan Ismail 50250 Kuala Lumpur
TEL: 60-3-2697-2920

先鋒股份有限公司

台灣台北市內湖區瑞光路 407 號 8 樓 TEL: 886-(0)2-2657-3588

先鋒電子(香港)有限公司

香港九龍長沙灣道 909 號 5 樓 TEL: 852-2848-6488

PIONEER ELECTRONICS DE MEXICO S.A. DE C.V.

Blvd. Manuel Avila Camacho 138 10 piso Col. Lomas de Chapultepec, Mexico, D.F. 11000 TEL: 52-55-9178-4270

PIONEER INDIA ELECTRONICS PRIVATE LTD.

216, Second Floor, Time Tower, M.G. Road, Sector 28, Gurgaon 122001, Haryana, India TEL: +91-124-463-6100

PDJ_001_all

Printed in

<DRH1330-A>

