



# ROYER R-10

## Ribbon-Velocity Studio Microphone

The Royer R-10 is a passive mono ribbon microphone designed for critical studio and live performance applications. Its compact size and mounting configuration allows for flexible placement with minimum intrusion. The R-10 exhibits a flat frequency response and a well-balanced soundfield, while at the same time handling sound pressure levels of up to 160 dB @ 1 kHz.

The R-10 incorporates advancements pioneered by Royer Labs, including a multi-layered wind screen and an internally shock-mounted ribbon transducer. The layered wind screen provides superior protection from air blasts and plosives, and also reduces proximity effect so guitar cabinets and acoustic instruments can be close miked with less bass build-up. The R-10's internally shock-mounted ribbon transducer assembly isolates the ribbon element from shocks and vibrations and increases ribbon durability.

The R-10 is a perfect choice for electric guitars, brass instruments and drums, and its figure-8 pattern conveys superb ambience and depth when used for room miking applications. The R-10's smooth frequency response, phase linearity and lack of self-distortion make it ideal for digital recording.

The R-10 incorporates Royer's patented offset-ribbon technology and low mass, 2.5-micron (99.9% pure) aluminum ribbon element. A custom designed impedance-matching transformer minimizes saturation and the open grill configuration minimizes standing waves and associated comb-filtering effects. The transducer's flux-frame design and rare earth Neodymium magnets create a powerful magnetic field which increases sensitivity while reducing stray magnetic radiation.

The R-10's patented offset-ribbon design positions the ribbon element towards the front of the transducer, which allows for the higher SPL handling of the front (logo) side and the option of a brighter response when recording lower SPL sound sources on the back side (3 feet or closer; phase reversed position).

### R-10 FEATURES

- High SPL capability for electric guitar, brass and other close miking applications
- Multi-layered wind screen provides superior protection to ribbon element
- Internally shock-mounted ribbon transducer gives increased durability
- Passive design and custom transformer minimize high SPL overload
- Extremely low residual noise
- Ribbon element not affected by heat or humidity
- Absence of high-frequency peaks, "ringing" and phase shifts
- Equal sensitivity from front or back of the element

### RECOMMENDED APPLICATIONS

- Close miking in the studio and on live stages
- Electric & acoustic guitars
- Drum overheads, kick drum (see manual for position), room miking
- Percussion instruments
- Brass, horn sections
- Strings - solo & sections
- Acoustic piano
- Vocals



# ROYER R-10

## Technical Specifications

---



<b>Acoustic Operating Principle</b>	Electrodynamic pressure gradient
<b>Polar Pattern</b>	Figure-8
<b>Generating Element</b>	2.5-micron aluminum ribbon
<b>Magnets</b>	Rare Earth Neodymium (Grade 52)
<b>Frequency Response</b>	30Hz-15,000Hz +/- 3dB
<b>Sensitivity</b>	-54dBv (re. 1v/pa)
<b>Output Impedance</b>	100 Ohms
<b>Maximum SPL</b>	135dB @ 50 Hz, 160dB @ 1kHz
<b>Recommended Load Impedance</b>	700 Ohms (or greater)
<b>Output Connector</b>	Male XLR 3-pin (Pin 2 Hot)
<b>Dimensions</b>	Length including mounting base: 5 7/8 inches (149 mm) Width 1 3/8 inches (35 mm)
<b>Weight</b>	13 oz (368 grams)
<b>Shipping Weight</b>	Single: 2.5 lbs, Matched Pair: 4 lbs
<b>Accessories</b>	Microphone Holder, Mic Sock, Carrying Case
<b>Microphone</b>	Adjustable Swivel Mount (Black)
<b>Microphone Warranty</b>	Five Years, First re-ribbon free in first year



Matched pairs are available at extra charge

## Frequency Response and Polar Pattern

---

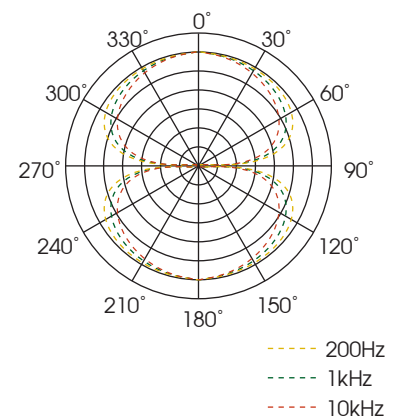
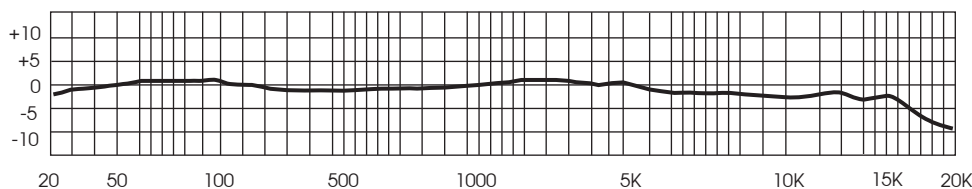

**Royer Labs**

[www.royerlabs.com](http://www.royerlabs.com)

2711 Empire Ave, Burbank, CA 91504

Tel. (818) 847-0121 Fax (818) 847-0122

COPYRIGHT ROYER LABS 2017  
All specifications subject to  
change without notice