

## P502WL/P502HL/P502WL-2/P502HL-2 Installation Guide

### Desktop and Ceiling Mount

Rev 1.0

#### Contents

Product Description, Lens Specs, Screen/Aspect Ratio	
Notes	Pg 1
Distance Charts and Formulas, Ceiling Mount/Desktop Installation	Pg 2-3
Lens Shift Adjustable Range	Pg 4
Cabinet Dimensions	Pg 5
Cabinet Dimensions	Pg 6
Ventilation Requirements/Regulatory Stickers	Pg 7
Input Panel and Button Panel	Pg 8
Control Codes	Pg 9



#### Product Description

Type:	1 chip DMD Reflection Type 0.65 in. 2x LVDS DMD	Dimensions: 18.5"(W) x 5.4"(H) x 14.4"(D) Weight: 19.2lbs. / 8.7kg
Resolution:	P502WL/P502WL-2: 1280 x 800 (16:10) P502HL/P502HL-2: 1920 x 1080 (16:9)	Brightness: 5000 Lumens
Fan Noise:	39 dB / 33dB @ 1 meter	
Power Consumption: 464W (max)		BTU's: 1583 BTU/hour
Network Ready, integrated wired networking Power: Lens Shift, Horizontal & Vertical /Zoom/ Focus		

#### Lens Specifications

Throw Ratio:	P502WL/P502WL-2: 1.3 – 2.2:1 (for 100" diagonal) P502HL/P502HL-2: 1.24 – 2.1:1 (for 100" diagonal)	Focal Length: 18.2mm – 31.1mm
Offset Angle:	4.8° - 8.0° (for 100" diagonal)	F/#: 2.0
Screen Sizes:	30" - 300" diagonal	Manual Focus/Manual Zoom

#### Screen/Aspect Ratio

**4:3, 16:9 and 16:10 screens are fully supported** with proper aspect ratio control for both type sources using NEC developed scaling technology. Menu selections have settings for each screen type and aspect ratio control for each source type.

#### Notes

- For screen sizes not indicated on the projection tables, use the formulas below.  
If the figures on the tables do not match the results of formulas, use the figures in the table..
- Distances are in inches, for millimeters multiply by 25.4.
- Distances may vary ±5%.

## P502WL/P502HL/P502WL-2/P502HL-2 Installation Guide

Desktop and Ceiling Mount

Rev 1.0

### Diagrams and Distance Charts

The following shows the proper relative positions of the projector and screen. Refer to the table to determine the position of installation. Distances are in inches. For millimeters multiply by 25.4.

#### Ceiling Mounted

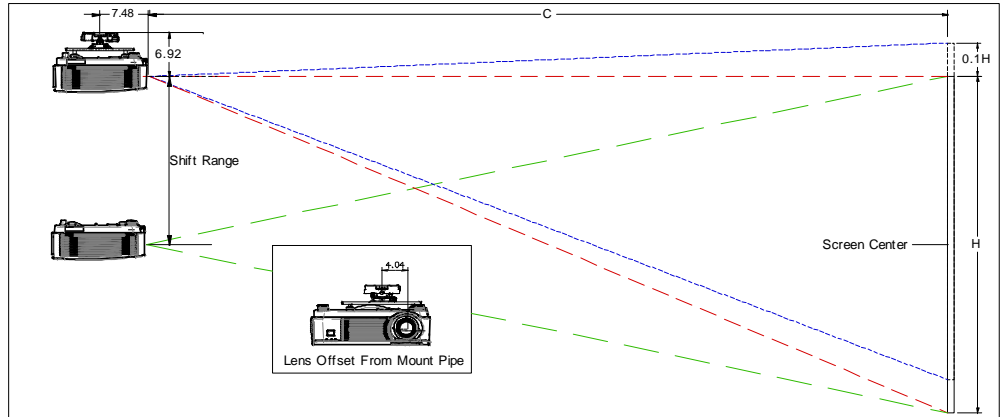

#### Desktop

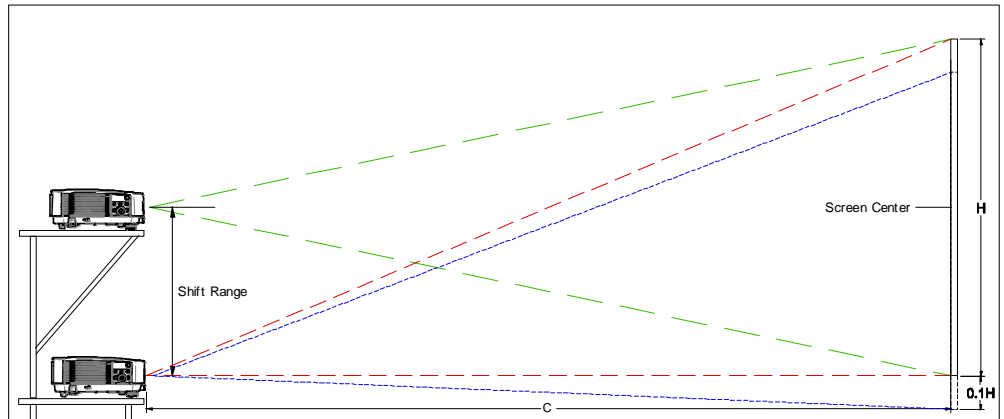

### Distance Chart for popular 16:10 screens

#### 16:10 Screen Formulas:

$$W = H \times 16/10$$

$$H = W \times 10/16$$

$$\text{Screen Diagonal} = W \times 18.868/16$$

#### Projection Formulas:

$$B = 0.369W$$

$$C \text{ (wide)} = 1.309W - 1.457$$

$$C \text{ (tele)} = 2.248W - 1.404$$

$$D \text{ (max)} = -0.056W$$

$$D \text{ (min)} = 0.313W$$

$$\alpha \text{ (wide)} = \tan^{-1} (B/C(\text{wide}))$$

$$\alpha \text{ (tele)} = \tan^{-1} (B/C(\text{tele}))$$

**Note:** For screen sizes not indicated on the projection tables, use the formulas on page 1.

Screen Size (16:10)			B	C		D		$\alpha$	
Diagonal	Width(W)	Height (H)		wide - tele	max - min	max - min	wide - tele	degrees	
inches	inches	inches	inches	inches	inches	inches	degrees	degrees	
57	48	30	18	61 - 107	-3 - 15	16.1 - 9.4			
66	56	35	21	72 - 124	-3 - 18	16.0 - 9.4			
68	58	36	21	74 - 128	-3 - 18	16.0 - 9.4			
75	64	40	24	82 - 142	-4 - 20	16.0 - 9.4			
79	67	42	25	87 - 150	-4 - 21	16.0 - 9.4			
85	72	45	27	93 - 160	-4 - 23	16.0 - 9.4			
92	78	49	29	101 - 175	-4 - 25	16.0 - 9.4			
98	83	52	31	107 - 186	-5 - 26	15.9 - 9.4			
102	86	54	32	112 - 193	-5 - 27	15.9 - 9.4			
111	94	59	35	122 - 211	-5 - 30	15.9 - 9.4			
113	96	60	35	124 - 214	-5 - 30	15.9 - 9.4			
123	104	65	38	135 - 232	-6 - 33	15.9 - 9.4			
125	106	66	39	137 - 236	-6 - 33	15.9 - 9.4			
147	125	78	46	162 - 279	-7 - 39	15.9 - 9.4			
149	126	79	47	164 - 283	-7 - 40	15.9 - 9.4			
213	181	113	67	235 - 405	-10 - 57	15.8 - 9.4			
255	216	135	80	281 - 484	-12 - 68	15.8 - 9.3			
270	229	143	84	298 - 513	-13 - 72	16 - 9			
300	254	159	94	332 - 570	-14 - 80	16 - 9			

## P502WL/P502HL/P502WL-2/P502HL-2 Installation Guide

Desktop and Ceiling Mount

Rev 1.0

### Diagrams and Distance Charts

The following shows the proper relative positions of the projector and screen. Refer to the table to determine the position of installation. Distances are in inches. For millimeters multiply by 25.4.

#### Ceiling Mounted

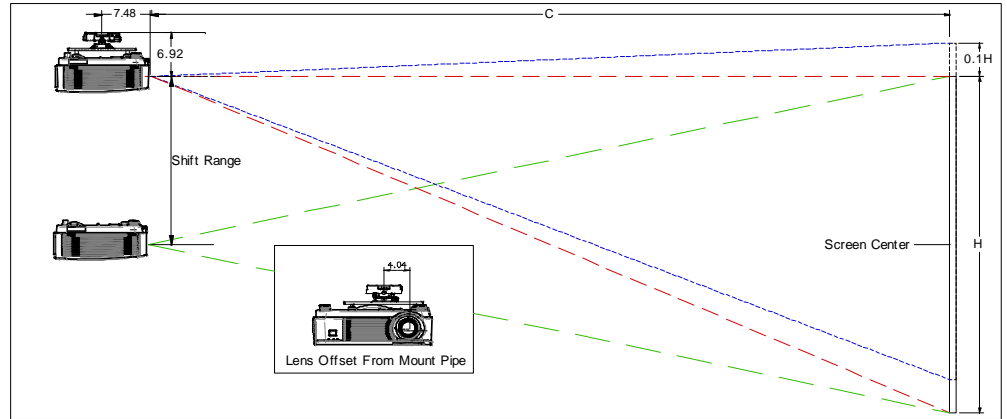

#### Desktop

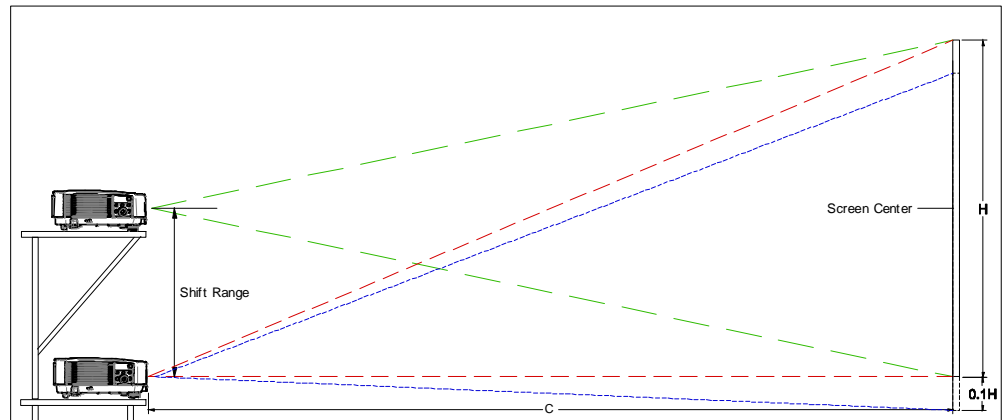

### Distance Chart for popular 16:9 screens

#### 16:9 Screen Formulas:

$$W = H \times 16/9$$

$$H = W \times 9/16$$

$$\text{Screen Diagonal} = W \times 18.358/16$$

#### Projection Formulas:

$$B = 0.369W$$

$$C \text{ (wide)} = 1.247W - 1.426$$

$$C \text{ (tele)} = 2.142W - 1.374$$

$$D \text{ (max)} = -0.068W$$

$$D \text{ (min)} = 0.281W$$

$$\alpha \text{ (wide)} = \tan^{-1} (B/C(\text{wide}))$$

$$\alpha \text{ (tele)} = \tan^{-1} (B/C(\text{tele}))$$

**Note:** For screen sizes not indicated on the projection tables, use the formulas on page 1.

Screen Size (16:9)			B inches	C wide - tele inches	D max - min inches	$\alpha$ wide - tele degrees
Diagonal inches	Width(W) inches	Height (H) inches				
61	53	30	20	63 - 110	4 - 15	17.5 - 10.2
71	62	35	23	74 - 129	4 - 17	17.4 - 10.1
73	64	36	24	76 - 133	4 - 18	17.4 - 10.1
82	71	40	26	85 - 148	5 - 20	17.3 - 10.1
86	75	42	28	89 - 156	5 - 21	17.3 - 10.1
92	80	45	30	96 - 167	5 - 22	17.2 - 10.1
100	87	49	32	104 - 182	6 - 24	17.2 - 10.1
106	92	52	34	111 - 194	6 - 26	17.2 - 10.0
110	96	54	36	115 - 201	7 - 27	17.2 - 10.0
120	105	59	39	126 - 220	7 - 29	17.1 - 10.0
122	107	60	40	128 - 224	7 - 30	17.1 - 10.0
133	116	65	43	139 - 243	8 - 32	17.1 - 10.0
135	117	66	44	142 - 247	8 - 33	17.1 - 10.0
159	139	78	51	168 - 292	9 - 39	17.0 - 10.0
161	140	79	52	170 - 296	10 - 39	17.0 - 10.0
230	201	113	75	244 - 425	14 - 56	17.0 - 9.9
275	240	135	89	293 - 508	16 - 67	16.9 - 9.9

## P502WL/P502HL/P502WL-2/P502HL-2 Installation Guide

### Desktop and Ceiling Mount

Rev 1.0

#### Lens Shift Adjustable Range

##### Lens Shift Range for Desktop and Ceiling Mount Application

The diagram below shows the location of the image position in the lens for the P502WL. The P502WL has a maximum horizontal lens shift range of +/- 28% and a maximum vertical lens shift of + 59%. The lens can be shifted within the shaded area as shown using the normal projection position as a starting point.

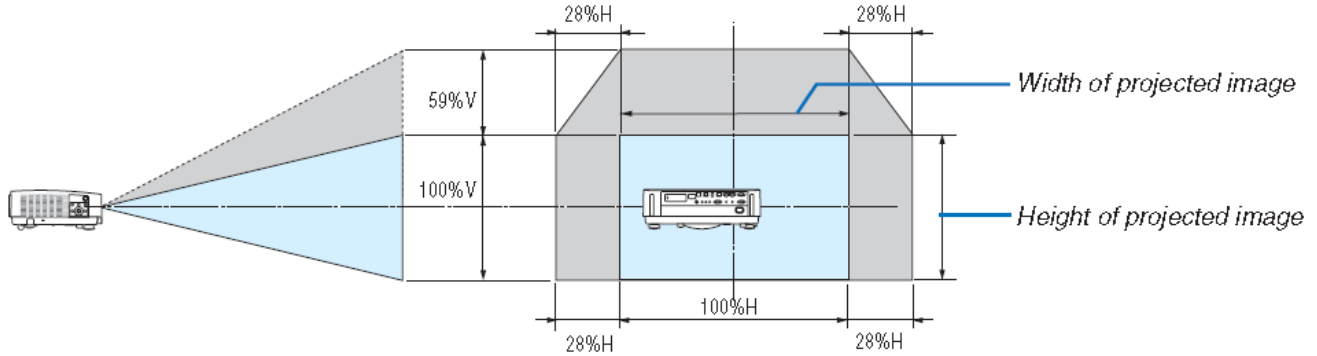

##### Lens Shift Range for Desktop and Ceiling Mount Application

The diagram below shows the location of the image position in the lens for the P502HL. The P502HL has a maximum horizontal lens shift range of +/- 25% and a maximum vertical lens shift of + 62%. The lens can be shifted within the shaded area as shown using the normal projection position as a starting point.

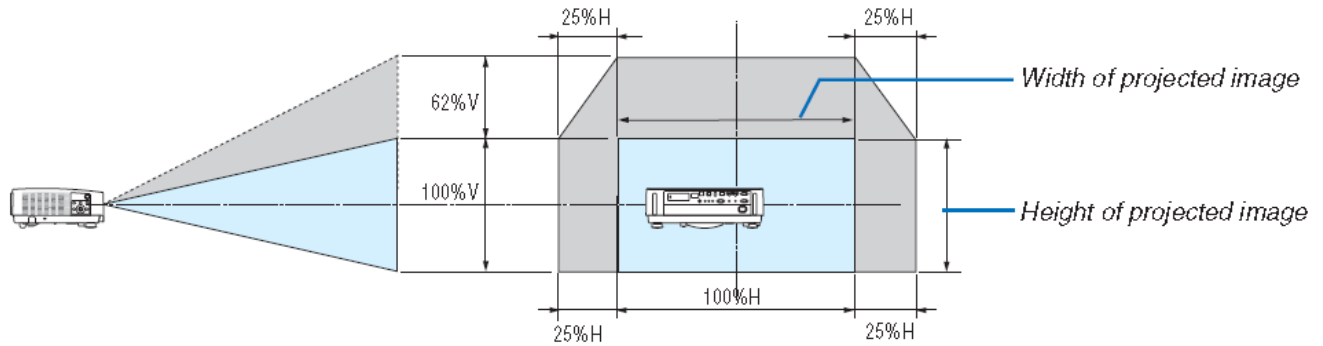

**Note:** Projector is set out of the box at center position, which is how it is depicted above.  
(H: width of projected image, V: height of projected image)

## P502WL/P502HL/P502WL-2/P502HL-2 Installation Guide

Desktop and Ceiling Mount

Rev 1.0

### Cabinet Dimensions

The following diagrams show the cabinet dimensions for the P502WL\_P502HL. Dimensions are in inches. For millimeters multiply by 25.4.

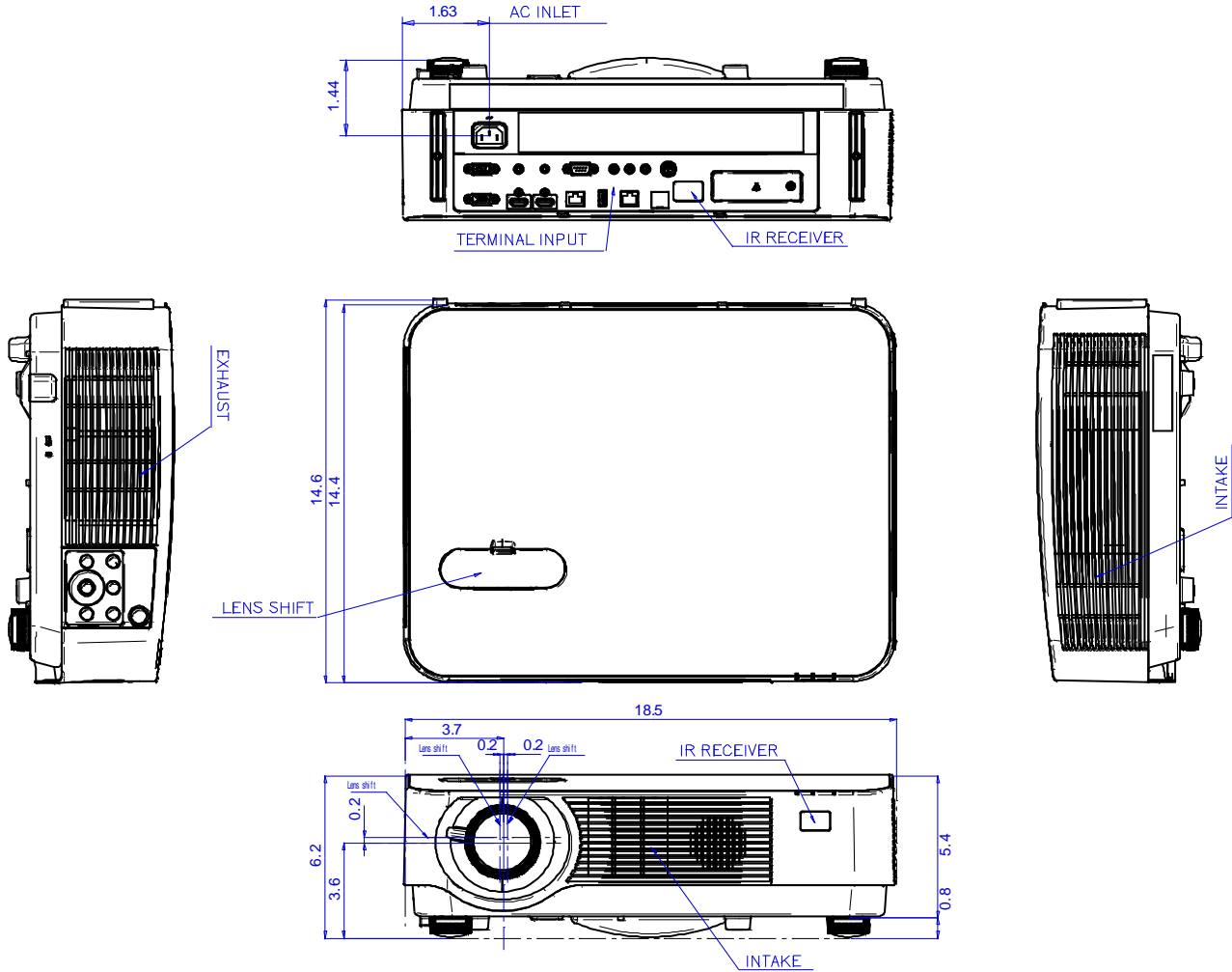

## P502WL/P502HL/P502WL-2/P502HL-2 Installation Guide

Desktop and Ceiling Mount

Rev 1.0

### Cabinet Dimensions

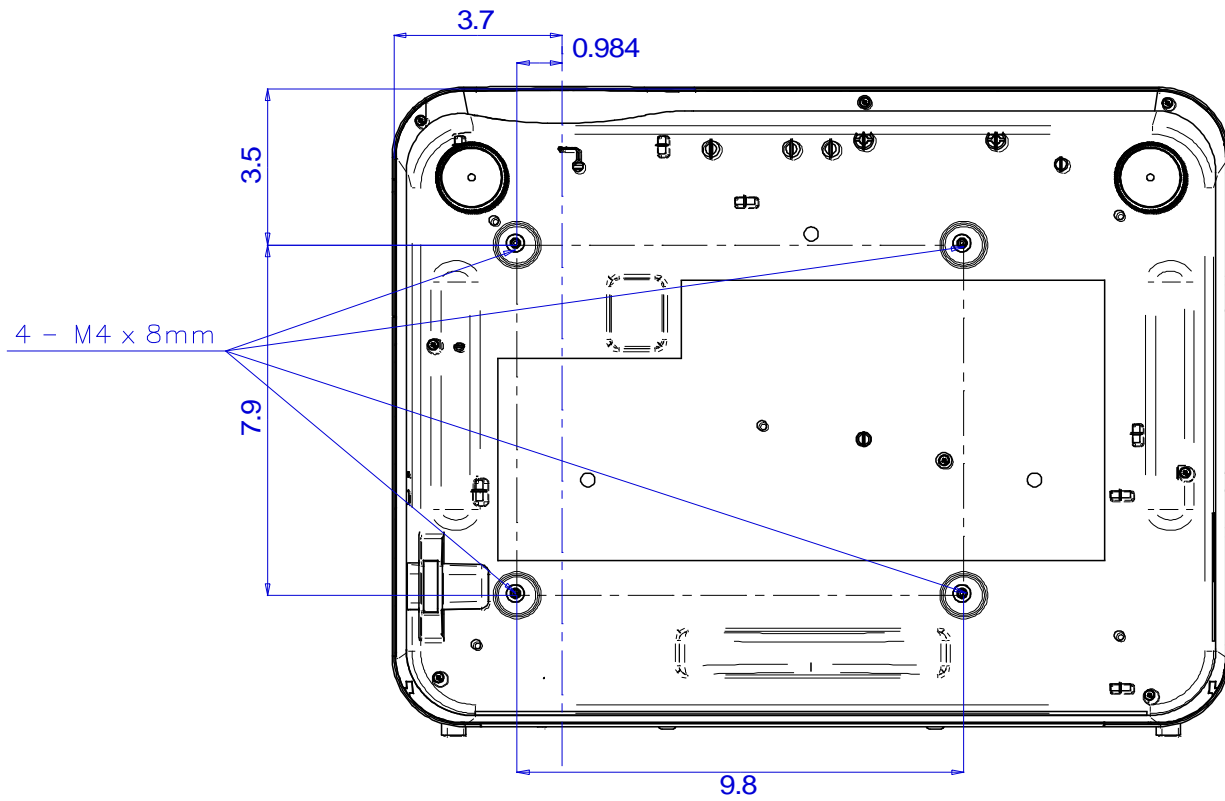

## P502WL/P502HL/P502WL-2/P502HL-2 Installation Guide

Desktop and Ceiling Mount

Rev 1.0

### Ventilation Requirements

- If installed on a portrait stand :

(Unit: mm)

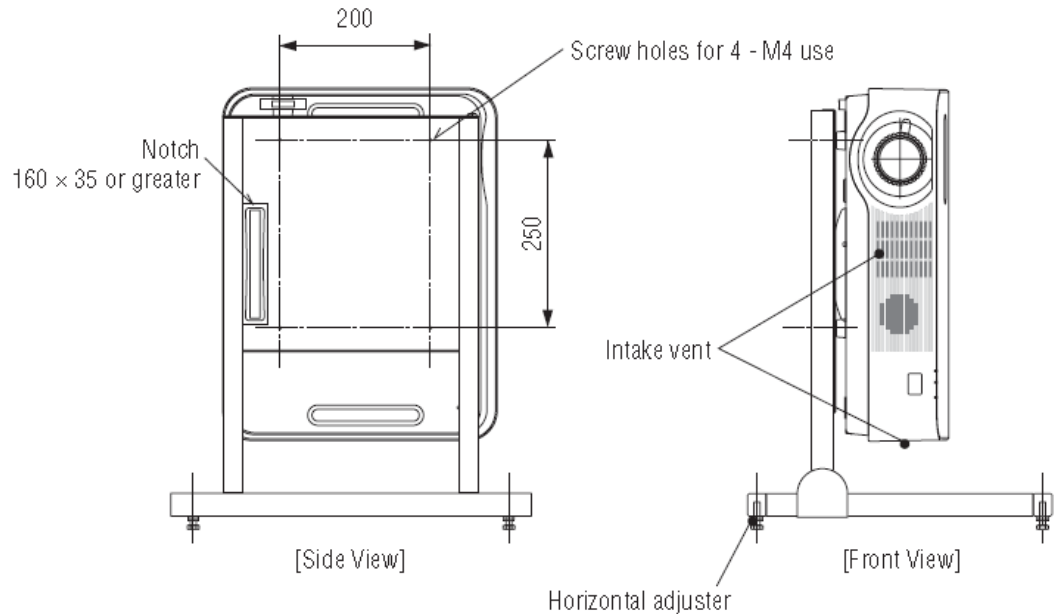

### Regulatory Stickers

Label 1:

	<p><b>LASER RADIATION</b> DO NOT STARE INTO BEAM CLASS 2 LASER PRODUCT WAVE LENGTH: 450-460 nm MAX OUTPUT: 14.12 mW PULSE DURATION: 0.85 ms IEC/EN 60825-1:2007</p>	<p><b>RAYONNEMENT LASER</b> NE PAS FIXER LE FAISCEAU DU REGARD PRODUIT LASER DE CLASSE 2 LONGUEUR D'ONDE : 450-460 nm SORTIE MAXIMALE : 14.12 mW DURÉE DE L'IMPULSION : 0.85 ms IEC/EN 60825-1:2007</p>	<p><b>LASERSTRAHLUNG</b> NICHT IN DEN STRAHL SCHAUEN LASERPRODUKT DER KLASSE 2 WELLENLÄNGE: 450-460 nm MAXIMALE AUSGANGSLEISTUNG: 14.12 mW IMPULSDAUER: 0.85 ms IEC/EN 60825-1:2007</p>
	<p>CLASS 1 LASER PRODUCT IEC/EN 60825-1: 2014</p>	<p>PRODUIT LASER DE CLASSE 1 IEC/EN 60825-1: 2014</p>	<p>LASERPRODUKT DER KLASSE 1 IEC/EN 60825-1:2014</p>

COMPLIES WITH 21 CFR 1040.10 AND 1040.11 EXCEPT FOR DEVIATIONS PURSUANT TO LASER NOTICE No. 50, DATED JUNE 24, 2007

Label 2:

	<p><b>CAUTION</b> POSSIBLY HAZARDOUS OPTICAL RADIATION EMITTED FROM THIS PRODUCT. DO NOT STARE AT OPERATING LAMP. MAY BE HARMFUL TO THE EYES. RISK GROUP 2 IEC 62471:2006</p>	<p><b>VORSICHT</b> Dieses Produkt strahlt eventuell gefährliche optische Strahlung aus. Schauen Sie nicht in die eingeschaltete Lampe. Dies kann Ihre Augen gefährden. RISIKOGRUPPE 2 IEC 62471:2006</p>
--	---	--

## P502WL/P502HL/P502WL-2/P502HL-2 Installation Guide

Desktop and Ceiling Mount

Rev 1.0

### Input Panel

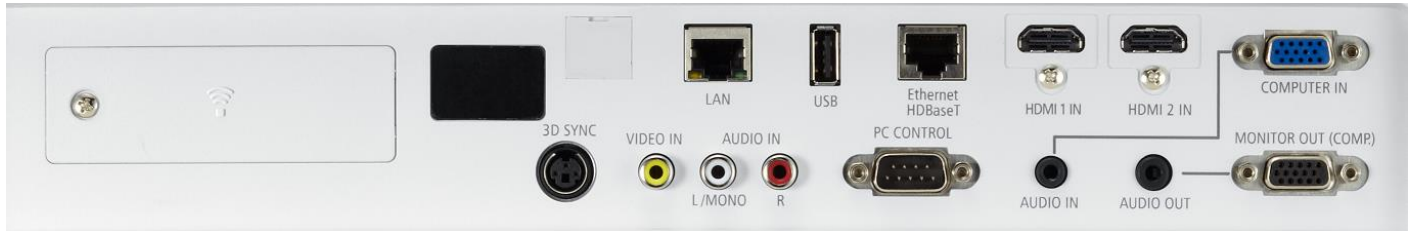

### Control Panel





## P502WL/P502HL/P502WL-2/P502HL-2 Installation Guide

Desktop and Ceiling Mount

Rev 1.0

### PC Control Codes

Function	Code Data
POWER ON	02H 00H 00H 00H 00H 02H
POWER OFF	02H 01H 00H 00H 00H 03H
INPUT SELECT COMPUTER	02H 03H 00H 00H 02H 01H 01H 09H
INPUT SELECT HDMI 1	02H 03H 00H 00H 02H 01H 1AH 22H
INPUT SELECT HDMI 2	02H 03H 00H 00H 02H 01H 1BH 23H
INPUT SELECT VIDEO	02H 03H 00H 00H 02H 01H 06H 0EH
INPUT SELECT APPS	02H 03H 00H 00H 02H 01H 20H 28H
INPUT SELECT HDBaseT	02H 03H 00H 00H 02H 01H 22H 2AH
PICTURE MUTE ON	02H 10H 00H 00H 00H 12H
PICTURE MUTE OFF	02H 11H 00H 00H 00H 13H
SOUND MUTE ON	02H 12H 00H 00H 00H 14H
SOUND MUTE OFF	02H 13H 00H 00H 00H 15H

### Cable Connection

#### Communication Protocol:

- Baud Rate: 38400 bps (for cable lengths longer than 20', it is recommended changing to 9600 bps in setup menu)
- Data Length: 8 bits
- Parity: No Parity
- Stop Bit: One bit
- X on/off: None
- Communications: Full duplex

#### PC Control Connector (D-Sub 9P)

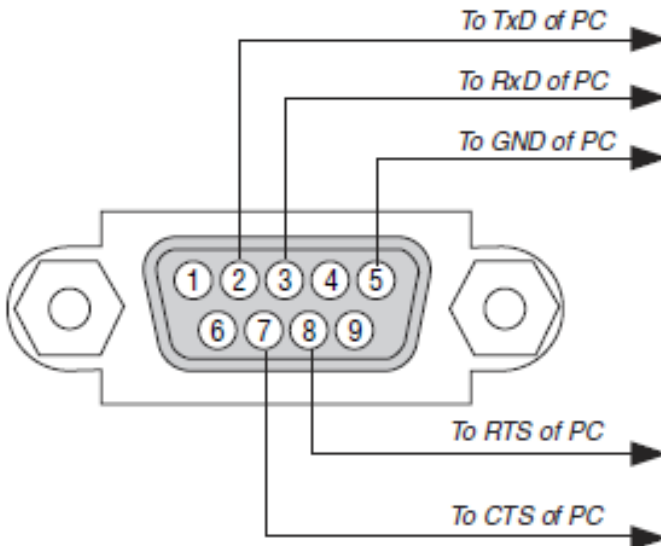

**Note 1 :** Pins 1, 4, 6, and 9 are used inside the projector.

**Note 2:** For long cable runs it is recommended to set communication speed within the projector to 9600 bps.

**Note 3:** Jumper "Request to Send" and "Clear to Send" together on both ends of the cable to simplify cable connection.