

Equalizers

EQP-KT

Classic Tube Equaliser with
Switchable Frequency Selection,
Variable Bandwidth and
Custom-Built MIDAS Transformers



- ⊗ Single-channel, two-band equaliser based on the classic Pultec* EQP-1A
- ⊗ Class A, all discrete circuitry for highest signal integrity
- ⊗ Premium selection 12AX7 and 12AU7 tubes
- ⊗ Custom-built MIDAS input and output transformers
- ⊗ Switchable frequency selectors with up to 7 frequency points
- ⊗ Independent boost and cut controls provide immense creative potential
- ⊗ Variable bandwidth control for wide sound sculpting
- ⊗ Inductor based equaliser section
- ⊗ Bypass feature allows for A/B comparison
- ⊗ Transformer balanced inputs and outputs on Neutrik* XLR connectors
- ⊗ Rugged 2U rackmount chassis for durability in portable applications
- ⊗ Auto-ranging universal switch-mode power supply
- ⊗ 3-Year Warranty Program*
- ⊗ Designed and engineered in the U.K.

If ever there is an official “Audio Technology Hall of Fame”, it will definitely include a shrine to the legendary Pultec EQP-1A. We pay homage to this audio-processing pioneer that has graced so many recordings, with our EQP-KT Classic Tube Equaliser. And while vintage Pultec units are extremely rare and expensive, the EQP-KT is amazingly affordable – and designed for the 21st Century. Mastering quality equalisation, at a price point that makes the EQP-KT equally at home in your studio – and your live rack!



Building on a Classic

The EQP-KT draws inspiration from the legendary Pultec EQP-1A equaliser, which was first produced in the early 1950s. Since then, Pultec equalisers have been prized for their smooth musical sound, and audio engineers have utilised them at all stages of the recording process – from tracking to mastering.



*All third-party trademarks are the property of their respective owners. Their use neither constitutes a claim of the trademark nor affiliation of the trademark owners with MUSIC Group. Product names are mentioned solely as a reference for compatibility, effects and/or components. Warranty details can be found at music-group.com.

Equalizers

EQP-KT

Classic Tube Equaliser with
Switchable Frequency Selection,
Variable Bandwidth and
Custom-Built MIDAS Transformers

A Class Act

At the heart of the EQP-KT is a vintage Class-A circuit design constructed from the highest-quality discrete components – all of which meet or exceed the Pultec EQP-1A's original specifications. This is just one of the many ways the EQP-KT brings unparalleled precision and superb signal integrity into the new audio age.



The Warm Sound of Tubes

EQP-KT owes its characteristic warmth to a set of premium, hand-selected 12AX7 and 12AU7 tubes. This time-tested combination provides ultra low-noise analog output with the ideal balance of tight, warm bass, silky-smooth midrange and brilliant, airy treble.

MIDAS – The Legend in Sound Quality

Ever since its formation in the 1970s, MIDAS has had a long history of innovation and leadership in the world of audio mixing consoles. Employed by the most famous touring acts and installations worldwide, legendary MIDAS consoles such as the XL4 and Heritage H3000 quickly became industry standards.

MIDAS has earned an impeccable reputation due to their no-compromise approach for audio and build-quality, and in particular for their Award-winning Mic Preamps, considered by experts as the industry's best-sounding designs. Building on this legacy, the XL8 and PRO Series of Live Mixing Systems continue this great heritage of Award-winning audio quality.

KLARK TEKNIK is proud to incorporate custom-designed MIDAS Input and Output transformers in the EQP-KT for the ultimate in high-quality audio reproduction in both live and studio environments. Find out more about MIDAS' amazing legacy by visiting their extensive website.



Equalizers

EQP-KT

Classic Tube Equaliser with
Switchable Frequency Selection,
Variable Bandwidth and
Custom-Built MIDAS Transformers



Incredible Flexibility

EQP-KT provides the kind of tone-sculpting flexibility that you simply won't find on the average equaliser, such as the ability to boost and cut specific frequency content simultaneously. This functionality is a product of EQP-KT's two-band design, which allows the boost and cut controls to work independently of one another – for incredibly flexible shelving. Both the LF Boost/Cut and HF Boost controls provide 7 frequency selections, along with a variable broad-bandwidth midrange control. Finally, EQP-KT's HF Cut control lets you dial in the perfect amount of "air" to add a touch of finesse to your top-end content.

Bypass Mode

As mentioned earlier, the EQP-KT is anything but typical, and that includes the operation of its Bypass/EQ On switch. If you could see EQP-KT's signal path, you'll find: a [MIDAS](#) Input transformer; two-band equaliser; a makeup gain amplifier; and a [MIDAS](#) Output transformer. When the switch is in the Bypass position, the only section that is no longer part of the signal path is the equaliser.



Balanced Connections

The EQP-KT has both XLR and 1/4" TRS balanced Inputs and Outputs, both of which operate at line level. Unbalanced connections are also available via 1/4" TS cables.

Equalizers

EQP-KT

Classic Tube Equaliser with
Switchable Frequency Selection,
Variable Bandwidth and
Custom-Built MIDAS Transformers

Unequaled Equalisation

While Pultec may have written the book on studio equalisation with the legendary EQP-1A in the 1950, we just added a new chapter to that venerable tone – the **KLARK TEKNIK** EQP-KT! Now audio aficionados of all means can afford the amazingly precise, tone-sculpting technology that has defined generations of musical excellence – both on and off the stage.

Check out the EQP-KT at your **KLARK TEKNIK** dealer, or get yours online today!



You Are Covered

We always strive to provide the best possible Customer Experience. Our products are made in our own **MUSIC Group** factory using state-of-the-art automation, enhanced production workflows and quality assurance labs with the most sophisticated test equipment available in the world. As a result, we have one of the lowest product failure rates in the industry, and we confidently back it up with a generous **3-Year Warranty** program.

Equalizers

EQP-KT

Classic Tube Equaliser with
Switchable Frequency Selection,
Variable Bandwidth and
Custom-Built MIDAS Transformers

Dimensions

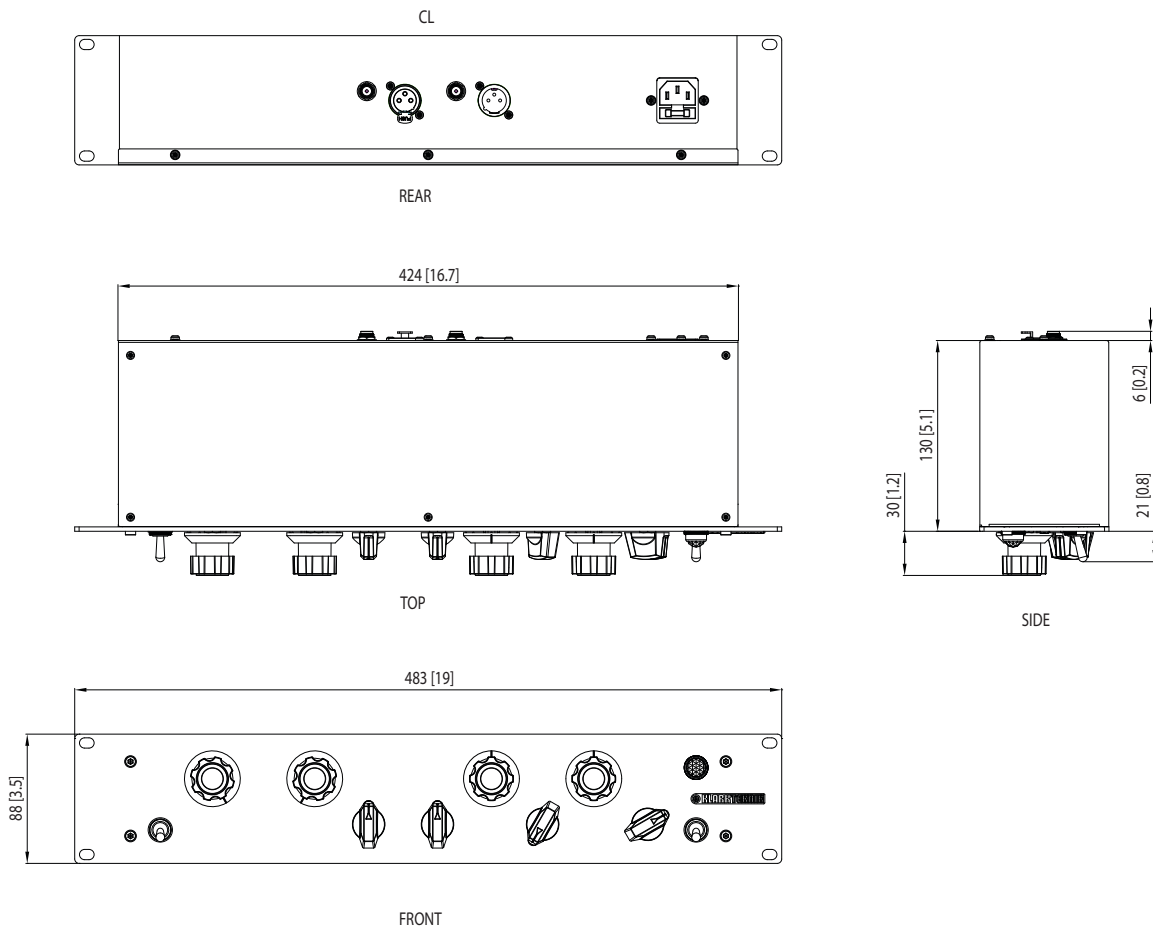

Equalizers

EQP-KT

Classic Tube Equaliser with
Switchable Frequency Selection,
Variable Bandwidth and
Custom-Built MIDAS Transformers

Technical Specifications

Audio Input

Type	XLR, ¼" TRS, transformer balanced
Impedance	>600 Ω, balanced and unbalanced
Max. input level	+21 dBu
Optimum input level	+4 dBu

Audio Output

Type	XLR, ¼" TRS, transformer balanced
Min. output load impedance	600 Ω
Impedance	<300 Ω, balanced and unbalanced
Max. output level	+21 dBu

System Specifications

Frequency response	20 Hz to 20 kHz, ±1 dB
Distortion (THD+N)	<0.1% @ 1 kHz, +4 dBu
Dynamic range (20 Hz to 20 kHz unweighted)	>101 dB, typical
S/N ratio	80 dB @ +4 dBu In
Circuit	Class-A
Vacuum tubes	12AX7, 12AU7

Filters

Low Frequency Cut / Boost Section

Boost	0 to 12 dB, shelving
Cut	0 to -24 dB, shelving
LF boost / cut	20, 30, 60, 100, 200, 400, 800 Hz, selectable

High Frequency Boost Section

Boost	0 to 12 dB, shelving
	0 to +10 dB (Broad)
HF boost	3, 4, 5, 8, 10, 12, 16 kHz, selectable
Bandwidth	Q = 1 to 10 (sharp to broad), selectable

High Frequency Cut Section

Cut	0 to -20 dB, shelving
HF cut	3, 4, 5, 10, 20 kHz, selectable

Power Supply

Mains voltage	100 – 240 V~, 50/60 Hz
Power consumption	15 W
Fuse	T1AH 250V
Mains connection	Standard IEC receptacle

Physical

Dimensions (H x W x D)	88 x 483 x 167 mm (3.5 x 19 x 6.6")
Weight	3.0 kg (6.6 lbs)

EQP-KT

Classic Tube Equaliser with
Switchable Frequency Selection,
Variable Bandwidth and
Custom-Built MIDAS Transformers

Architecture & Engineering Specifications

The equaliser shall provide a passive single channel two band program equaliser with valve driven transformer output stage in a standard 2U 19" rack mount chassis.

The equaliser low frequency band shall provide:

A separate boost control with a range of 0 to +12 dB with shelving response

A separate cut control with a range of 0 to -24 dB with shelving response

A separate seven position rotary frequency selector switch with frequency settings of 20, 30, 60, 100, 200, 400 and 800 Hz

The equaliser high frequency boost band shall provide:

A separate boost control with a range of 0 to +15 dB (Sharp) and 0 to +10 dB (Broad) bell response

A separate seven position rotary frequency selector switch with frequency settings of 3, 4, 5, 8, 10, 12 and 16 kHz

A separate bandwidth control with a Q range of 1 (Sharp) to 10 (Broad)

The equaliser high frequency cut band shall provide:

A separate cut control with a range of 0 to -20 dB with shelving response

A separate five position rotary frequency selector switch with frequency settings of 3, 4, 5, 10 and 20 kHz

The equaliser shall have an equalisation section bypass switch.

The input and output audio connections shall be transformer balanced and shall have 3 pin XLR and parallel TRS jack connectors.

The equaliser shall be fitted with an internal switch mode power supply, capable of operation at AC voltages ranging from 100 to 240 VAC, at 50/60Hz. The mains connector shall be a standard IEC receptacle.

The equaliser dimensions shall be 88 mm high x 483 mm wide x 167 mm deep (3.5 x 19 x 6.6"). The nominal weight shall be 3.0 kg (6.6 lbs).

The equaliser shall be the **KLARK TEKNIK** model EQP-KT, and no other alternative shall be acceptable.

Equalizers

EQP-KT

Classic Tube Equaliser with
Switchable Frequency Selection,
Variable Bandwidth and
Custom-Built MIDAS Transformers



Equalizers

EQP-KT

Classic Tube Equaliser with
Switchable Frequency Selection,
Variable Bandwidth and
Custom-Built MIDAS Transformers



For service, support or more information contact the KLARK TEKNIK location nearest you:

Europe
MUSIC Group Services UK
Tel: +44 156 273 2290
Email: CARE@music-group.com

USA/Canada
MUSIC Group Services NV Inc.
Tel: +1 702 800 8290
Email: CARE@music-group.com

Japan
MUSIC Group Services JP K.K.
Tel: +81 3 6231 0454
Email: CARE@music-group.com

MUSIC Group accepts no liability for any loss which may be suffered by any person who relies either wholly or in part upon any description, photograph, or statement contained herein. Technical specifications, appearances and other information are subject to change without notice. All trademarks are the property of their respective owners. MIDAS, KLARK TEKNIK, LAB GRUPPEN, LAKE, TANNØY, TURBOSOUND, TC ELECTRONIC, TC HELICON, BEHRINGER, BUGERA and DDA are trademarks or registered trademarks of MUSIC Group IP Ltd.
© MUSIC Group IP Ltd. 2016 All rights reserved.

