

LS-AES

Owner's Manual



Contents

Contents	1
Introduction	2
Before You Begin.....	2
Contents	2
Optional Equipment	2
System Requirements	2
Manual Conventions	3
Warranty Registration	3
Locating the Serial Number of Your LS-AES	3
Installation Procedure	4
LynxTWO/L22 Driver.....	4
LynxTWO/L22 Firmware	4
LS-AES Internal Card Installation	5
External Connections	6
LynxTWO / L22 Mixer Controls	7
LStream Panel Control Description.....	7
Digital I/O Panel Description.....	8
LStream Interface to the Host LynxTWO/L22	9
LS-AES Output Routing.....	10
Output Channel Source Selection.....	10
LStream Output Channel Group Mapping	11
LS-AES Input Routing	12
WideWire Channel Mapping.....	13
Clocking and Synchronization	14
Dual Card Systems	14
Support	15
Digital I/O Port Pinout:	15
Specifications	16
License Agreement	17
Limited Warranty	17

Introduction

Thank you for purchasing the LS-AES™! We are proud to provide you with a reliable, professional quality product for your digital audio requirements.

This manual provides basic information to help you get started. Additional information is available via our web site and email support. Please refer to the support section at the end of this manual for support contact information.

The LS-AES is an 8-channel AES/EBU or S/PDIF LStream™ interface module that is designed for use with the LynxTWO and L22 professional audio interfaces. The device communicates via Lynx's proprietary LStream multi-channel interface.

The internal header LStream port on the LynxTWO/L22 provides support for connecting two LS-AES internal cards. In this case, the number of AES or S/PDIF channels is doubled.

Before You Begin

We recommend that you read through the manual to acquire an overview of the installation procedure and use of the LS-AES. You should have a working knowledge of Windows and general PC concepts. Additionally, refer to the User's Guide included with your LynxTWO or L22.

Contents

Verify that you received the following in the LS-AES shipping carton:

- LS-AES card in cushioned antistatic bag
- LS-AES digital I/O cable (six-foot cable with eight XLR connectors)
- LS-AES LStream cable (gray ribbon cable with three IDC connectors)
- Warranty Registration Card

Optional Equipment

The following equipment may be required depending on the configuration of your system and the type of devices the LS-AES is connected to:

- Lynx P/N CBL-XFDRM18: female S/PDIF adapter cable for digital outputs
- Lynx P/N CBL-XMDRM18: male S/PDIF adapter cable for digital inputs

System Requirements

Verify that your computer meets or exceeds the following the system requirements specified in the LynxTWO or L22 User's Guide.

The LS-AES requires one expansion card position in your computer. A PCI slot **is not required**. The LS-AES derives all signals from the host LynxTWO/L22 card via the LStream ribbon cable.

Manual Conventions

The term “LynxTWO/L22” is a reference to either the LynxTWO or L22. Both products are compatible with the LS-AES.

This manual uses the following typographic conventions:

- ALL UPPER CASE text denotes the names of specific connectors.
- *Italic* text denotes emphasis or a warning.
- Phrases, such as Start > Programs > Lynx Studio Technology, use the greater than (“>”) sign to separate multiple menu options or icon names that are selected with a keyboard or mouse action.

Warranty Registration

We are committed to providing you with the best service possible. To help us serve you better, please be sure to register your LS-AES using one of the following methods:

- Fill out and mail the Warranty Registration Card included with your LS-AES.
- Register on the web at:
<http://www.lynxstudio.com/support.html>

Once you are registered you will automatically receive notifications of new products and upgrades.

Locating the Serial Number of Your LS-AES

To register your LS-AES, you must supply its serial number. The serial number is located on a label attached to the back of the card and on the shipping carton.

Installation Procedure

The following installation procedure must be followed in the order described to insure proper operation.

LynxTWO/L22 Driver

Verify that the driver installed for your LynxTWO/L22 is Build 049 or later. You can determine the driver version by selecting About Mixer in the Mixer menu of the LynxTWO/L22 Mixer. If you do not have the correct driver version it can be downloaded from the Lynx web site at <http://www.lynxstudio.com/download.html>. Refer to the Installation section of the LynxTWO or L22 User's Guide for more information related to driver installation.

LynxTWO/L22 Firmware

Verify that the version of firmware installed on your LynxTWO/L22 will support the LS-AES. You can determine the firmware version by selecting About Mixer in the Mixer menu of the LynxTWO/L22 Mixer. Verify the firmware version for your product is:

LynxTWO A Model: Rev 22 or later
LynxTWO B Model: Rev 8 or later
LynxTWO C Model: Rev 6 or later
L22: Rev 8 or later

If you do not have the correct firmware version installed, download the latest LynxTWO/L22 Firmware Update program from <http://www.lynxstudio.com/download.html>. This is a self-extracting archive file.

1. Start L2UpdateXX.exe.
2. When prompted, navigate to a temporary directory to store L2Update.
3. L2Update will automatically start.
4. Click the Update button to continue.
5. Click OK when prompted and wait for the update process to complete.
6. Power down your computer. ***A warm boot will not load the new firmware.***

LS-AES Internal Card Installation

1. If you are installing one LS-AES internal card, verify that a shorting jumper is in place on JP4 (refer to figure on following page for location). This will set the board's LStream bus address to 0. If you are installing a second LS-AES, remove the jumper to set the address of this card to 1. For dual-card installations, each card must be assigned a unique address and the **LStream Dual Internal** option must be checked in the advanced settings menu in the LynxTWO mixer.
2. With the computer powered down, install the LS-AES in a bracket slot adjacent to the LynxTWO/L22 as shown in the figure below. The LS-AES must be secured to the computer chassis with a screw.
3. The included LStream ribbon cable connects a LynxTWO/L22 to either one or two LS-AES internal cards. Locate the cable end terminated in both a 14-pin and 2-pin receptacle. Connect the 14-pin receptacle to the connector labeled JP1 on the LynxTWO/L22. Take care to align the polarizing tab on the cable connector with the slot on the board connector. **Failure to do may result in serious damage to the LynxTWO/L22 and LS-AES.** Snap the 2-pin cable receptacle to connector labeled JP2/CLOCK IN on the LynxTWO/L22.
4. Connect either of the two 16-pin cable connectors to connector JP1 on the LS-AES (labeled INT LSTREAM). Again, insure that the polarizing tab is aligned. In dual-card installations, both cable connectors are used.



LynxTWO and LS-AES Installation in Computer Chassis

External Connections

The following figure depicts the LS-AES circuit board layout and its connector.

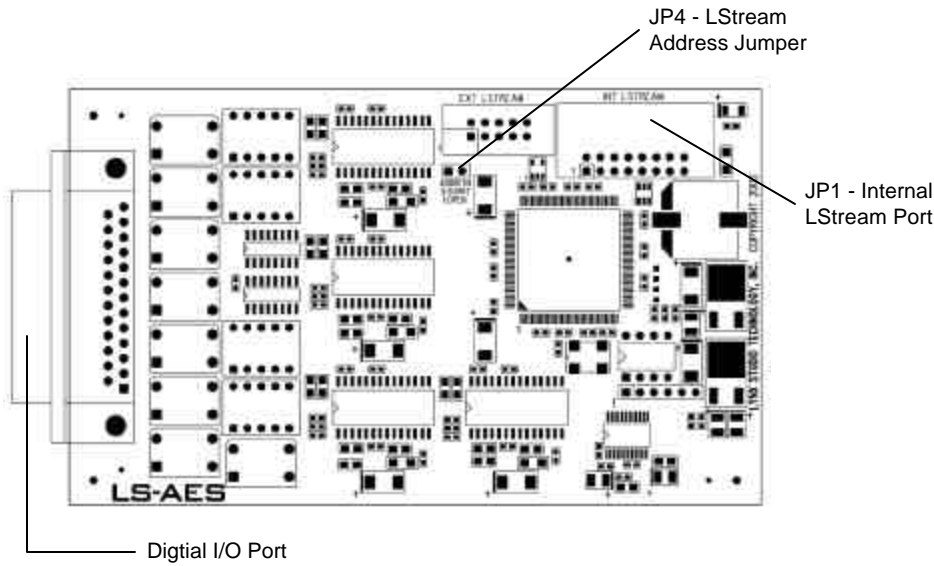

Connect the included breakout cable to the bracket-mounted Digital I/O Port connector on the LS-AES. The XLR connectors on the cable connect directly to equipment with AES/EBU ports. For S/PDIF coaxial connections, use Lynx XLR to RCA S/PDIF adapters (CBL-XFDRM18 and CBL-XMDRM18). The following table shows the audio signal channels associated with each cable connector.

Cable Connections	Digital I/O Channels
IN 1	Input channels 1 and 2
IN 2	Input channels 3 and 4
IN 3	Input channels 5 and 6
IN 4	Input channels 7 and 8
OUT 1	Output channels 1 and 2
OUT 2	Output channels 3 and 4
OUT 3	Output channels 5 and 6
OUT 4	Output channels 7 and 8

LynxTWO / L22 Mixer Controls

The LStream page of the LynxTWO/L22 Mixer contains controls for installed LStream interface cards. With the LS-AES installed, AES-specific controls are displayed as shown below.

The LStream page for the LS-AES contains five panels. The leftmost panel, labeled **LStream n**, includes controls pertaining to LStream and LS-AES routing. The remaining four panels, labeled **Digital I/O n**, provide control and status for the LS-AES’s digital inputs and outputs.

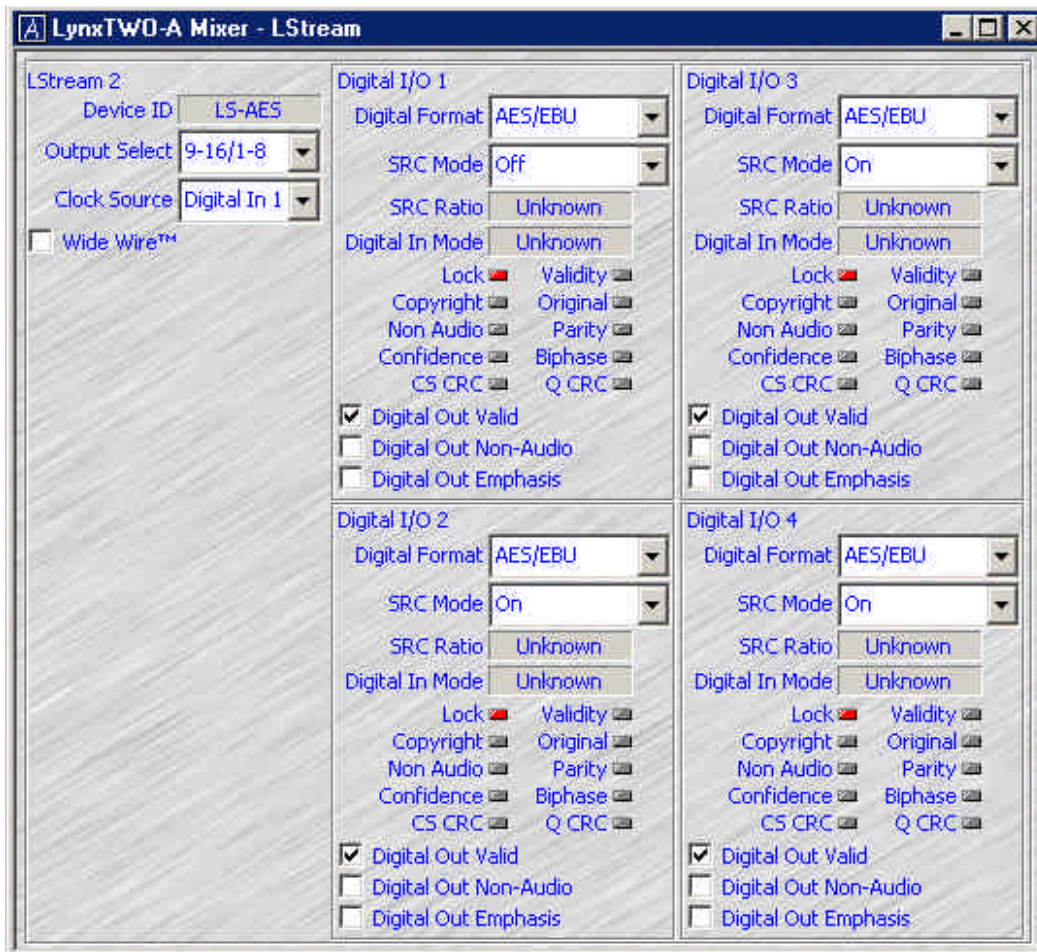

LStream Panel Control Description

Device ID	LStream device identification
Output Select	Controls routing of the eight upper and lower digital outputs from the host card to LStream channels.
Clock Source	Controls selection of the clock source for the LS-AES.
Wide Wire	Enables multi-wire digital I/O modes (side “WideWire” section)

NOTE: All LStream Panel controls are described in detail later in this manual.

Digital I/O Panel Description

Digital Format	Selects AES/EBU or S/PDIF formats. This control affects the electrical characteristics and channel status protocol on the digital input and output
SRC Mode	<p>Selects the sample rate converter mode:</p> <p>On - The sample rate converter is enabled on the digital input. The sample rate of the digital input signal is converted to the current rate selected for the host card and LS-AES. Bit-perfect digital transfers are not possible in this mode. This is the default mode. Use this mode when connecting to external equipment that is not synchronized to the LS-AES.</p> <p>Off - The sample rate converter is disabled. In this mode, the digital input signal must be synchronous to the clock source driving the host card and LS-AES in order to prevent signal errors. Digital input data is transferred bit-perfect. Use this mode when connecting to external devices that are locked to a clock source that is common to the LS-AES or host card. This mode is also valid if the digital input is selected as the clock source for the LS-AES.</p> <p>On: Digital Out – The sample rate converter is enabled on the digital output. The sample rate of the digital output signal is converted to the sample rate received on the corresponding digital input.</p>
SRC Ratio	Indicates the sample rate conversion ratio in either of SRC On modes.
Digital In Mode	Indicates either Professional or Consumer digital input status. Professional status is generally associated with an AES/EBU signal, and consumer status is generally associated with an S/PDIF signal.
Digital In Status Indicators	<p>Indicates various digital inputs status:</p> <p>Lock – Red: receiver PLL not locked, Green: receiver PLL locked</p> <p>Validity – Green: channel status validity bit set</p> <p>Copyright – Green: SCMS copyright bit set, consumer mode only</p> <p>Original – Green: SCMS original bit set, consumer mode only</p> <p>Non Audio – Green: channel status non-audio bit set. Typically set when non-PCM data is received, e.g. Dolby Digital, DTS</p> <p>Parity – Red: parity error detected</p> <p>Confidence – Red: signal quality degraded</p> <p>Biphase – Red: bi-phase coding error detected</p> <p>CS CRC – Red: channel status CRC error detected</p> <p>Q CRC – Red: subcode data CRC detected</p>
Digital Out Valid	Sets the validity bit in the digital output channel status.
Digital Out Non-Audio	Sets the non-audio bit in the digital output channel status. This bit must be set when transmitting non-PCM data such as Dolby Digital and DTS.
Digital Out Emphasis	Sets the emphasis bit in the digital output channel status.

LStream Interface to the Host LynxTWO/L22

The LS-AES communicates with the host card through Lynx's proprietary LStream interface. LStream is a high-speed TDM serial interface that supports up to 16 channels of bi-directional 24-bit audio data with synchronization and control information.

The individual channels of the LStream interface are integrated into the host card's on-board digital mixer. This allows LStream data, in this case AES data, to be freely routed and mixed with the host card's analog and digital audio I/O. Currently, the architecture of LynxTWO/L22 digital mixer supports a maximum of 16 input and 16 output channels that can be assigned as needed to the available physical I/O's. Controlling the digital mixer requires an understanding of the LynxTWO/L22 Mixer application. Please refer to the User's Guide included with the product you own for further details.

The number of channels supported on one LStream port varies with sample rate as follows:

Sample Rate	Speed	Number of LStream Channels per Port
44.1/48 kHz	Single	16*
88.2/96 kHz	Double	8
176.4/192 kHz	Quad	4

* The LS-AES uses the first eight channels of an LStream port in single speed mode

In dual-card installations, each card is assigned an individual LStream port, thereby doubling the number of signal channels

LS-AES Output Routing

As shown below and in the Outputs page of the LynxTWO/L22 Mixer application, 16 output channels are available from the digital mixer. Output channels 1-8 are wired to the analog outputs, AES digital output, loopback registers, *and* to both LStream ports. Channels 9-16 are wired only to LStream output channels. This connection scheme allows any (or all) of the digital mixer's output channels to be routed to the outputs of the LS-AES via the LStream interface. Please note, that the signals sent to host card's analog and digital outputs will be mimicked on the corresponding LS-AES channels if mixer outputs 1-8 are routed to the LS-AES.

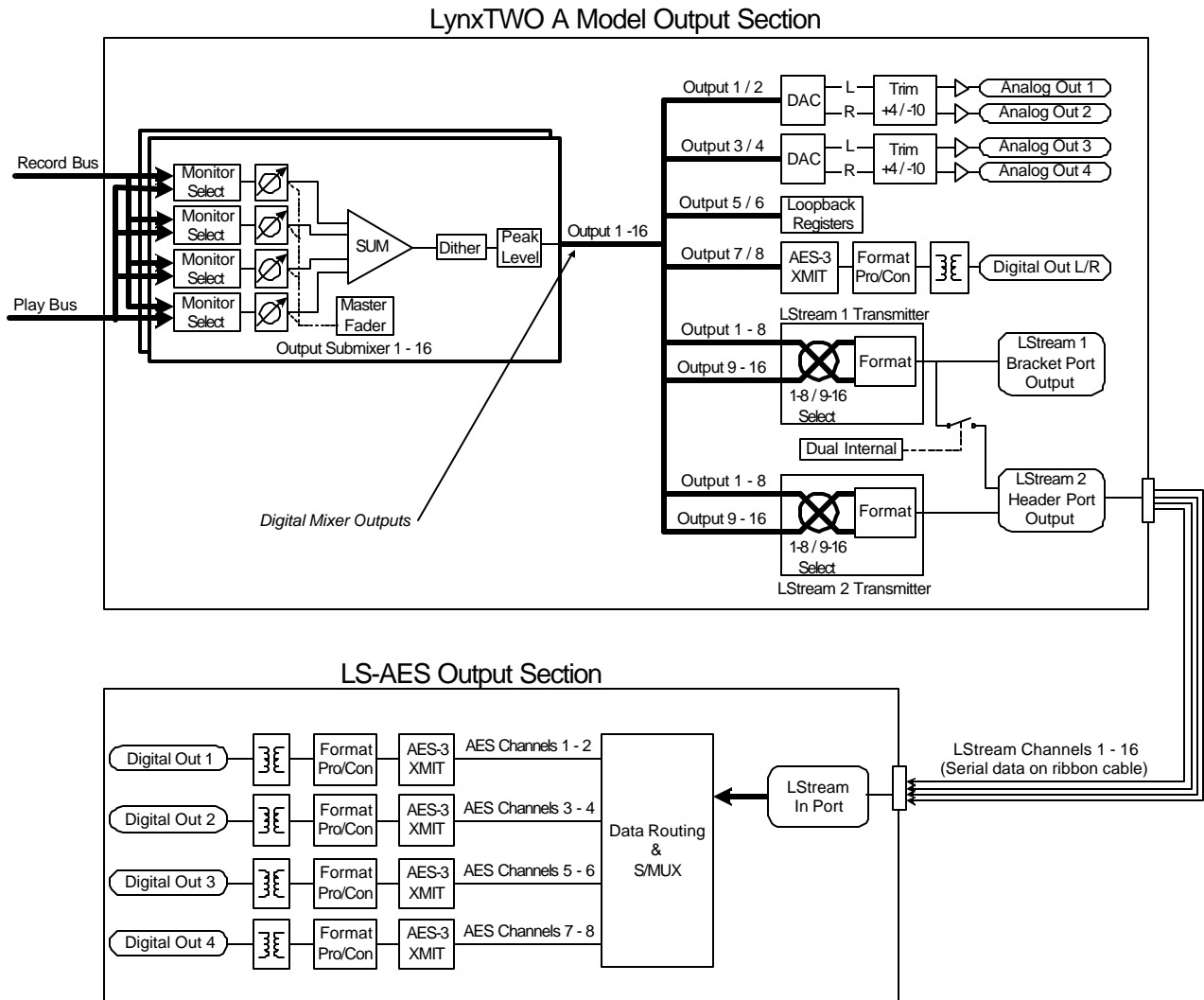

Output Channel Source Selection

As shown in the diagram, each digital mixer output channel is derived from a four-input submixer. The inputs to the submixer are recording and playback signals that can be selected using the Output Monitor Source select buttons. These buttons reside in the Outputs page of the LynxTWO/L22 Mixer just above the faders for each output channel. Choose up to four sources for each output. The mute button (labeled M) next to each Output Monitor Source button must be in the “out” position in order for the signal to be heard.

LStream Output Channel Group Mapping

The mapping of the digital mixer's output channels to LStream channels can be controlled to accommodate specific I/O configuration requirements. The Output Select control (labeled "1-8/9-16 Select" in the diagram above) allows the destination of the upper eight and lower eight mixer output channels to be altered. This feature is particularly useful for re-routing output channels 1 – 8, which are hardwired to the host card's analog and digital outputs and to the LStream ports.

The Output Select control on the LStream page of the LynxTWO/L22 Mixer has two settings:

9-16/1-8 Maps mixer output channels 9-16 to LStream output channels 1-8. This is the default setting.

1-8/9-16 Maps mixer output channels 1-8 to LStream output channels 1-8.

Typically, the default setting is easiest to work with since the LS-AES uses only the first eight LStream channels. This setting utilizes digital mixer outputs that are independent of those connected to the host card's analog and digital outputs.

Please note that this section pertains to the mapping of LStream channels, and not to LS-AES output channels. As will be discussed in a later section there is not always a one-to-one correspondence between LStream channels and LS-AES I/O channels.

LS-AES Input Routing

As shown below, the AES data from the LS-AES is routed into the digital mixer of the host card via the LStream 2 Header port. This data can be routed to the record bus using the Input Source Select function within each Input Submixer.

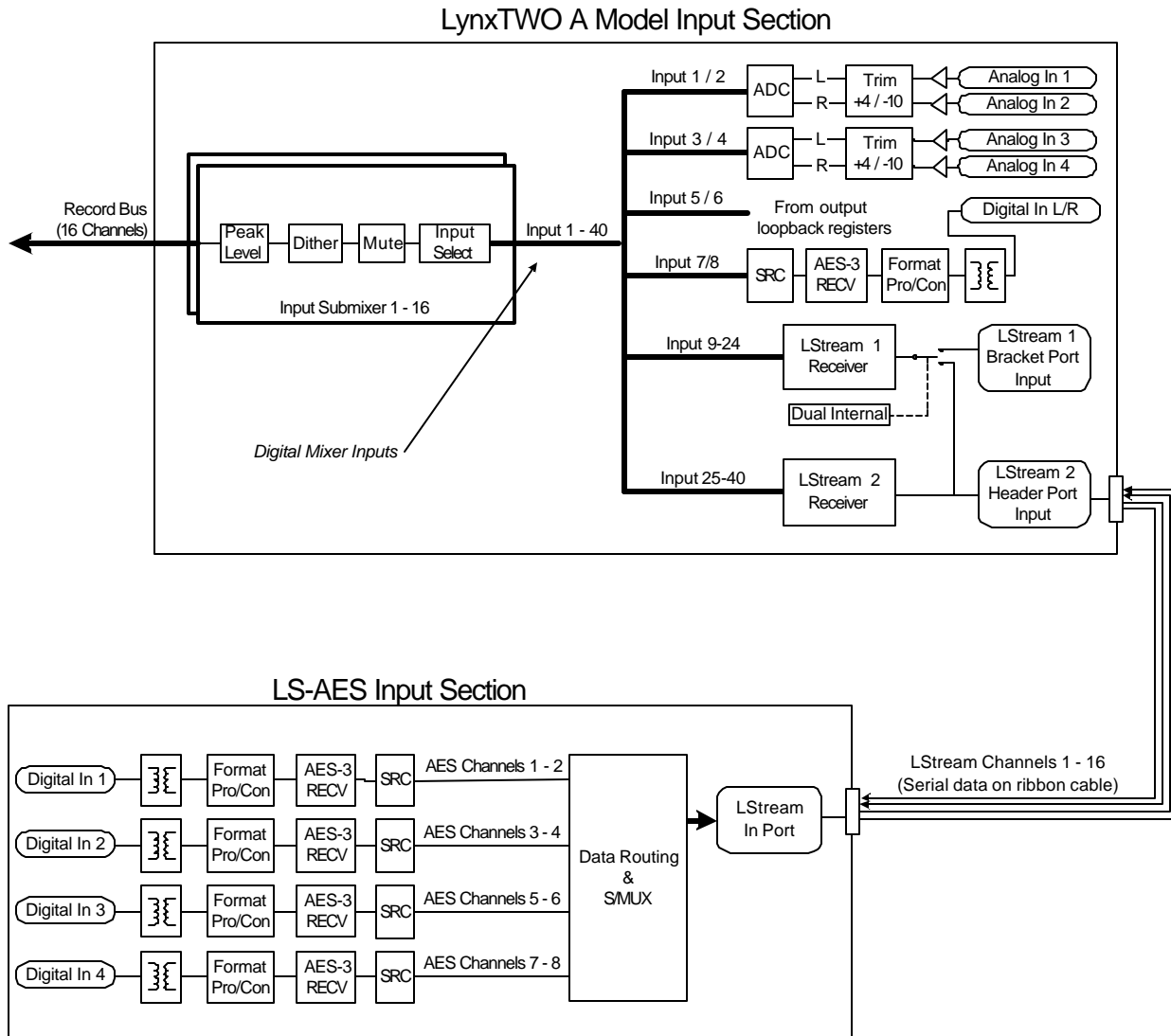

The Input Source Selection buttons on the Record/Play page of the LynxTWO/L22 Mixer provide access to the input select function. These buttons are located just above the meters for each input channel.

When these buttons are clicked, a menu containing the 40 possible input sources will be displayed. To access channels from the internal version of the LS-AES, choose sources from **LStream 2 In 1** through **LStream 2 In 8**. In dual-card installations with the second card assigned LStream bus address 1, choose sources from **LStream 1 In 1** through **LStream 1 In 8**

Each Input Source is routed to either the left or right channel of a record device. The record device number is located under the meters, e.g., Record 1, Record 2. When setting up for recording in an audio editing application, these device numbers are used to specify the recording source.

WideWire Channel Mapping

The WideWire feature of the LS-AES provides alternative multi-wire digital I/O connection modes for compatibility with legacy third party devices.

WideWire is enabled in the LStream window of the LynxTWO/L22 Mixer. When enabled, alternate dual and quad wire connections are available, but vary according to the signal sample rate according to the following table:

WideWire Sample Rates and I/O Modes

Signal Sample Rate (Hz)	WideWire ON/OFF	I/O Mode	LS-AES I/O Frame Rate
44.1k / 48k	Either	Single-wire	44.1k / 48k
88.2k / 96k	OFF	Single-wire	88.2k / 96k
88.2k / 96k	ON	Dual-wire	44.1k / 48k
176.4k / 192k	OFF	Dual-wire	88.2k / 96k
176.4k / 192k	ON	Quad-wire	44.1k / 48k

Dual-wire connections require two digital input or output connections to transfer two audio channels. Quad-wire connections require four digital input or output connections to transfer two audio channels. In each case, the number of active LStream channels is reduced. The LS-AES inputs and outputs used for each mode are shown in the following table.

WideWire Channel Mapping

LStream Channel	LS-AES INPUT/OUTPUT		
	Single-wire mode	Dual-wire mode	Quad-wire mode
1	IN/OUT 1 Left Channel	IN/OUT 1 Left and Right Channels	IN/OUT 1, L/R And IN/OUT 2, L/R
2	IN/OUT 1 Right Channel	IN/OUT 2 Left and Right Channels	IN/OUT 3, L/R And IN/OUT 4, L/R
3	IN/OUT 2 Left Channel	IN/OUT 3 Left and Right Channels	Not valid
4	IN/OUT 2 Right Channel	IN/OUT 4 Left and Right Channels	
5	IN/OUT 3 Left Channel	Not valid	
6	IN/OUT 3 Right Channel		
7	IN/OUT 4 Left Channel		
8	IN/OUT 4 Right Channel		

Clocking and Synchronization

The Clock Source control on the LStream page of the LynxTWO/L22 Mixer provides LS-AES clock source selection as follows:

Clock Source Selection	Action
Slave	LS-AES clock is slaved to the host card system clock source. The system clock source is selected on the Adapter page of the Mixer.
Digital In 1	The word clock derived from the digital IN 1 port is the clock source for the LS-AES and host card.
Digital In 2	The word clock derived from the digital IN 2 port is the clock source for the LS-AES and host card.
Digital In 3	The word clock derived from the digital IN 3 port is the clock source for the LS-AES and host card.
Digital In 4	The word clock derived from the digital IN 4 port is the clock source for the LS-AES and host card.

Important: *If a clock source other than Slave is used, the LynxTWO/L22 clock source must also be set to **Header** in the Adapter page of the Mixer.*

To insure glitch-free recording and playback using external AES devices *without enabling the LS-AES's sample rate converters*, the LS-AES, host LynxTWO/L22, and external AES devices must run synchronously from a common clock source. There are only two scenarios to consider that satisfy this requirement:

1. The LynxTWO/L22 host card is the clock master. The LS-AES and external AES devices must run in clock slave mode. This case includes host card synchronization to external clocks such as word clocks and composite video.
2. An external AES device is the clock master. The LS-AES clock source must be derived from one of its digital inputs and the host card clock source must be set to Header.

When the sample rate converter is enabled on a particular digital input of the LS-AES, the device driving the LS-AES does not have to run synchronously with the LS-AES. Data received from the input will be sample rate converted to rate of the clock source selected for the LS-AES.

Dual Card Systems

When using two LS-AES cards with one LynxTWO/L22, the clock source of at least one of the two cards *must be set to Slave*. Failure to do so will cause unstable clock generation.

To select a digital input from a second LS-AES (at LStream bus address 1) as the clock source:

- Select one of the Digital In clock sources (1-4) from the LStream 1 page
- Set the clock source on the LStream 2 page to Slave
- Select Header as the host card's clock source in the Adapter page of the LynxTWO/L22 Mixer

Support

We are devoted to making your experience with LS-AES trouble-free and productive. If you have questions or comments regarding the operation of your LS-AES please check the Troubleshooting topics on the Support section of the Lynx web site at:

<http://www.lynxstudio.com/support.html>

If you are unable to find information about your problem please email us at:

support@lynxstudio.com

In your email message include the following information:

- The serial number of your LS-AES and the serial number of your LynxTWO/L22.
- Which operating system you are using.
- The type of computer you are using.
- The name of the application you are using.
- A detailed description of the problem including any error messages you received.

We will provide a response in a timely manner.

Telephone support is available by calling (949) 515-8265, ext. 206 from 9AM to 5PM Pacific Time, Monday through Friday, excluding Holidays. Please have the above information available before calling.

Digital I/O Port Pinout

DB25 Pin	Signal	Connector Pin	DB25 Pin	Signal	Connector Pin
1	OUT 4 Hot	XLR 2	14	OUT 4 Cold	XLR 3
2	OUT 4 Gnd	XLR 1	15	IN 4 Hot	XLR 2
3	IN 4 Cold	XLR 3	16	IN 4 Gnd	XLR 1
4	OUT 3 Hot	XLR 2	17	OUT 3 Cold	XLR 3
5	OUT 3 Gnd	XLR 1	18	IN 3 Hot	XLR 2
6	IN 3 Cold	XLR 3	19	IN 3 Gnd	XLR 1
7	OUT 2 Hot	XLR 2	20	OUT 2 Cold	XLR 3
8	OUT 2 Gnd	XLR 1	21	IN 2 Hot	XLR 2
9	IN 2 Cold	XLR 3	22	IN 2 Gnd	XLR 1
10	OUT 1 Hot	XLR 2	23	OUT 1 Cold	XLR 3
11	OUT 1 Gnd	XLR 1	24	IN 1 Hot	XLR 2
12	IN 1 Cold	XLR 3	25	IN 1 Gnd	XLR 1
13	not connected				

Specifications

DIGITAL I/O	
Number	Four inputs and four outputs, transformer coupled
Format	24-bit AES/EBU or S/PDIF supported, on-board impedance and level switching
Wiring Modes / Sample Rates	Single-wire @ 32 kHz, 44.1 kHz, 48 kHz, 88.2 kHz, and 96 kHz sampling rates Dual-wire @ 88.2 kHz, 96 kHz, 176.4 kHz, and 192 kHz sampling rates Quad-wire @ 176.4 kHz and 192 kHz sampling rates
Channels	8 in/out in single-wire mode 4 in/out in dual-wire mode 2 in/out in quad-wire mode
Sample Rate Conversion	Support for conversion ratios up to 3:1. Available on any input or output.
Channel Expansion	Support for two LS -AES cards per LynxTWO or L22 provides double channel capacity
CLOCK SYNCHRONIZATION	
Clock Sources	Host card (LynxTWO or L22) or any LS -AES digital input
Modes	Master mode: utilizes LynxTWO or L22 low-jitter sample clock to drive external AES devices Slave mode: word clock derived from any digital input
ARCHITECTURE	
Core	FPGA -based core. Support for field upgrades of firmware.
Audio Devices	Via host card, the LS-AES's four digital inputs and outputs are visible to applications as four stereo record devices and four stereo play devices
Routing/Mixing	Integrates with host card's digital mixer to allow independent routing of AES I/O with host card analog and digital I/O
CONNECTIONS	
Digital I/O Ports	Bracket-mounted 25-pin female D-sub connector
LStream	Board-mounted header for connection to host audio card
GENERAL	
Host Interface	Lynx proprietary LStream™ Interface: 24.5 Mbps bi-directional
Requirements	One available bracket position (PCI slot not required), Host card: LynxTWO or L22
Size	2.990" H X 5.000" W
Shipping Weight	2.5 pounds
EMI Certifications	FCC and CE

License Agreement

This legal document is an agreement between you and Lynx Studio Technology, Inc. By opening the sealed board package, or written materials, you are agreeing to become bound by the terms of the agreement, which includes this License and Limited Warranty (collectively the "Agreement"). This Agreement constitutes the complete agreement between you and Lynx Studio Technology, Inc. If you do not agree to the terms of the Agreement, DO NOT OPEN the anti-static bag containing the LS-AES board. Promptly return the unopened package and all other items using the original packaging to the location of purchase.

Limited Warranty

Lynx Studio Technology, Inc. ("Lynx") warrants this product to be free of defects in material and workmanship for a period of one year from the date of original retail purchase. This warranty is enforceable only by the original retail purchaser. To be protected by this warranty, the purchaser must complete and return the enclosed warranty card within 14 days of purchase.

During the warranty period Lynx shall, at its sole and absolute option, either repair or replace free of charge any product that proves to be defective on inspection by Lynx or its authorized service representative. In all cases disputes concerning this warranty shall be resolved as prescribed by law.

To obtain warranty service, the purchaser must first call or write Lynx at the address and telephone number printed below to obtain a Return Authorization Number and instructions concerning where to return the unit for service. All inquiries must be accompanied by a description of the problem. All authorized returns must be sent to Lynx or an authorized Lynx repair facility postage prepaid insured and properly packaged. Proof of purchase must be presented in the form of a bill of sale, canceled check or some other positive proof that the product is within the warranty period. Lynx reserves the right to update any unit returned for repair. Lynx reserves the right to change or improve design of the product at any time without prior notice.

This warranty does not cover claims for damage due to abuse, neglect, alteration or attempted repair by unauthorized personnel, and is limited to failures arising during normal use that are due to defects in material or workmanship in the product.

ANY IMPLIED WARRANTIES, INCLUDING IMPLIED WARRANTIES OF MERCHANTABILITY AND FITNESS FOR A PARTICULAR PURPOSE, ARE LIMITED IN DURATION TO THE LENGTH OF THIS LIMITED WARRANTY. Some states do not allow limitations on how long an implied warranty lasts, so the above limitation may not apply to you.

IN NO EVENT WILL LYNX BE LIABLE FOR INCIDENTAL, CONSEQUENTIAL OR OTHER DAMAGES RESULTING FROM THE BREACH OF ANY EXPRESS OR IMPLIED WARRANTY, INCLUDING, AMONG OTHER THINGS, DAMAGE TO PROPERTY, DAMAGE BASED ON INCONVENIENCE OR ON LOSS OF USE OF THE PRODUCT, AND, TO THE EXTENT PERMITTED BY LAW, DAMAGES FOR PERSONAL INJURY. Some states do not allow the exclusion or limitation of incidental or consequential damages, so the above limitation or exclusion may not apply to you.

This warranty gives you specific legal rights, and you may also have other rights which vary from state to state.

This warranty only applies to products sold in the United States of America or Canada. The terms of this warranty and any obligations of Lynx under this warranty shall apply only within the country of sale. Without limiting the foregoing, repairs under this warranty shall be made only by a duly authorized Lynx service representative in the country of sale. For warranty information in all other countries please refer to your local distributor.

Your warranty will be in effect and you will receive warranty information ONLY IF YOU REGISTER YOUR LS-AES as described in the "Warranty Registration" section.

Lynx Studio Technology, LS-AES and the LS-AES Logo are trademarks of Lynx Studio Technology, Inc. All other product or company names are the trademarks or registered trademarks of their respective owners.

LS-AES™ Owner's Manual, printed 1/8/03

