

# DR66

W H E N   Y O U ' R E   M I X I N G   W I T H   P R O F E S S I O N A L S



- 24 bit Digital Mix Processor
- 6 in 6 out Audio System
- PC configuration software

**ALLEN**  
**&**  
**HEATH**

# INTRODUCTION

The **DR66** digital audio mix processor is a **full matrix mixer** with gain, levels, gates, compressors, graphic and parametric EQ's.

All this is housed in a discreet **1U case**, with removable ears for easy desk or rack mounting. **Allen & Heath WinDR software** makes custom system design simpler and more flexible than ever before.

All aspects of the system, from ducking and EQ's to front panel keys and password protection are conveniently **set by the installer**. For the operator, **DR66's** simple panel keys make everyday use **exceptionally easy and convenient**.

- **Cost effective solution to complex audio matrix systems**
- **Digital processing architecture allowing custom system design**
- **6 outputs with 2 mic/line and 4 line inputs**
- **WinDR System Manager configuration software**
- **Stand-Alone operation with simple user controls**
- **Password protected setup**
- **Many resources available: Ducking, Gates, Mix, Level, Limiter, Parametric EQs, Graphic Equaliser etc**
- **Designed to meet BS5839 installation requirements**
- **Custom Digital Technology with 24 Bit Conversion**
- **DSPx Expander option provides an additional 2 PEs for greater signal processing capability. 1 DSPx option can be fitted.**
- **DSPd Delay option provides up to 0.66s of delay on every output and can be fitted instead of a DSPx.**



## THE BEST MIX

DR66 employs the best mix of existing and new technologies to offer a beautifully simple yet extremely powerful solution for the systems designer. The circuitry uses both conventional and surface mount components for compactness and reliability. The power supply is a mix of switched-mode and linear topologies, giving the unit the ability to run from a single 24V battery backup in the event of a mains failure (conforming to BS5839). The advanced memory management at the heart of the system uses a mixture of DRAM and Flash memory, the latter enabling remote firmware upgrades via the RS232 port, eliminating the need for chip swapping.

## INNOVATION TO EXCELLENCE

Drawing together the unparalleled expertise of our sister companies in the Harman Group, we developed the revolutionary T-MIX ASIC (Application Specific Integrated Circuit). This powerful device provides the crucial interface between the DSP 'brain' of the unit and the input and output circuits. Each DR66 comes with two ASIC+DSP Processing Engines (PE). The first PE handles all mixing, level control, phase, metering and

output limiting, while the second PE executes a powerful selection of signal processing 'palettes' that can be configured and positioned by the installer. It is this unique architecture that defines the DR66 as an exceptional tool.

## SYSTEM PROTECTION

The DR66 provides safety and security with its battery backup, tamper-proof function keys, password access and alarm system integration. DR66 eliminates the need for costly return visits to installations for repairs and reconfiguration associated with racks of analogue equipment.



# WinDR

# DR66

## THE DR66 CAN BE SET UP USING PC COMPATIBLE WinDR SOFTWARE

Simply connect the PC to the DR66 unit and run the WinDR System Manager application. WinDR interrogates any DR66 unit attached for its configuration. Various functions of the system can then be viewed and edited as required. For example, Resource Palettes are selected to suit the application.

This provides a toolbox of audio processing blocks, e.g. Graphic or Parametric EQs that can be dragged onto the required Input or Output channels. The resource then appears as an icon in the channel strip.

Once allocated, a simple click on the icon creates a window where the resource can be viewed and modified. Different variations of the resource

palettes can then be stored in patches on disk or downloaded to the DR66.

In addition to the Resource Palettes, all DR66 functions can be easily configured from WinDR i.e. Crosspoint Mix Matrix, Ducker, Password & Security, Function Key assign, Remote Switch Event assign, Time/Date.

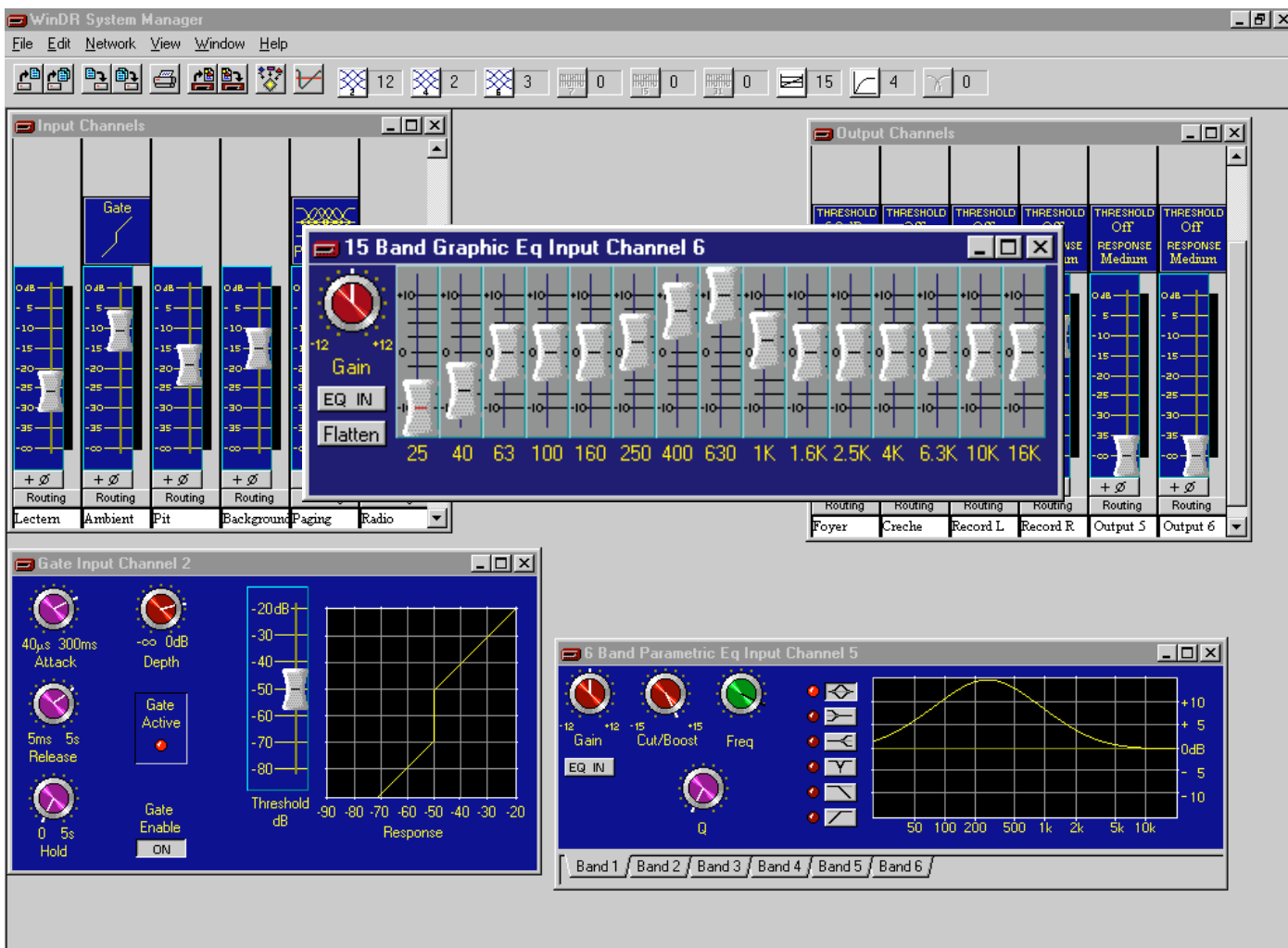

A free fully working version of WinDR software can be downloaded from the Allen & Heath Website :  
<http://www.allen-heath.com>

- 32-bit Windows 95™ application
- Communicates with DR66 via PC's serial port using an AES-24 ready, object-oriented communications protocol
- Can be run On-Line or Stand-Alone for remote system configuration
- On-Line connection provides real-time control and monitoring of all DR66 functions
- Allows configuration and archiving of installation setups

Region for allocating Palette Resources. Click on channel resource to view and edit.  
 Note: All 8 Outputs have limiters assigned to them as default.  
 Real-time signal meters on all inputs and outputs.

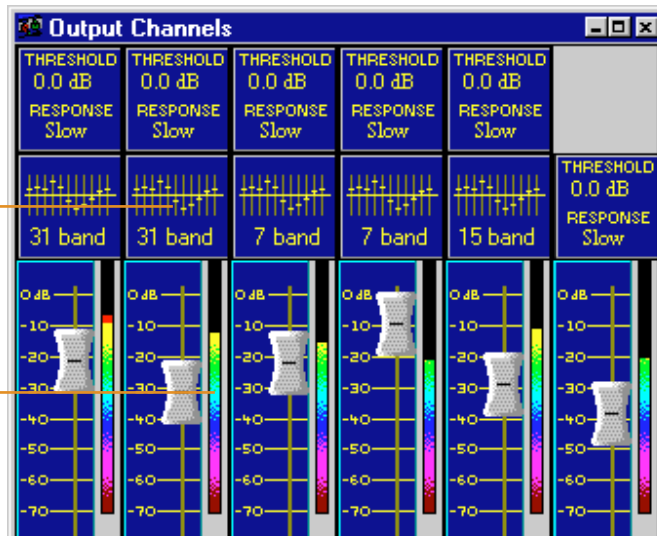

Region for naming input and output channels.

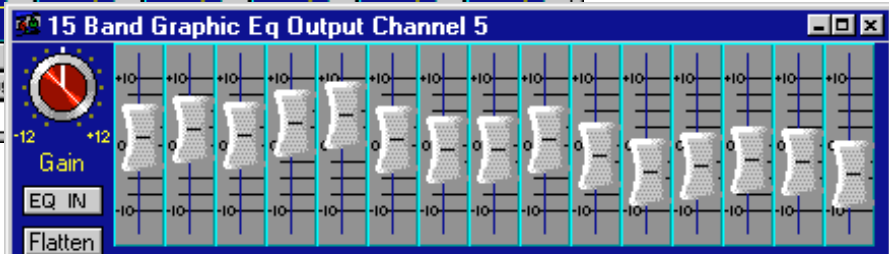

### RESOURCE PALETTES

To optimize the Digital Signal Processing power provided in the DR128, audio signal processing elements are provided in Resource Palettes.

Resource Palettes provide 'toolboxes' containing the audio processing blocks required for particular applications.

Each palette contains a certain number of Graphic EQs Parametric EQs & Gates, etc. that can be allocated to input channels as required. Each Processing Engine can be allocated its own Resource Palette.

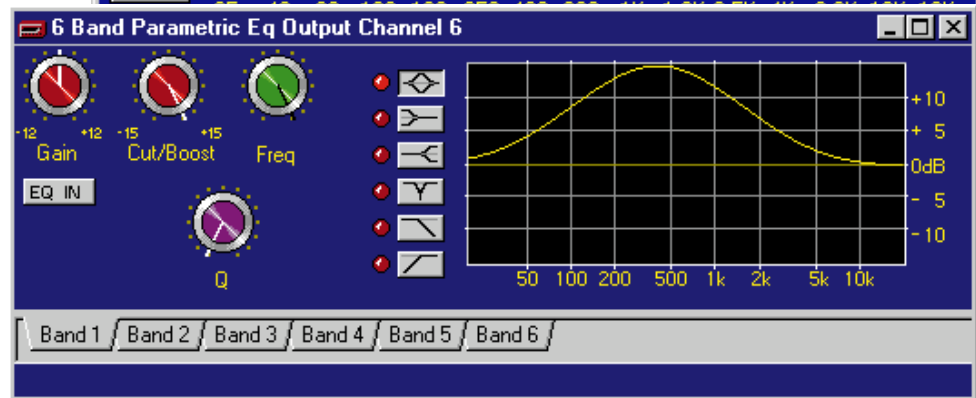

Resource icon - drag and drop onto channel strip to allocate. Number indicates unallocated resources remaining.

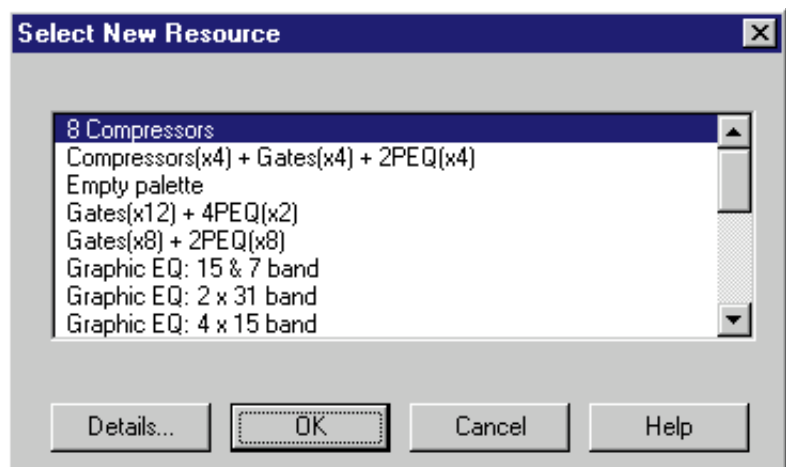

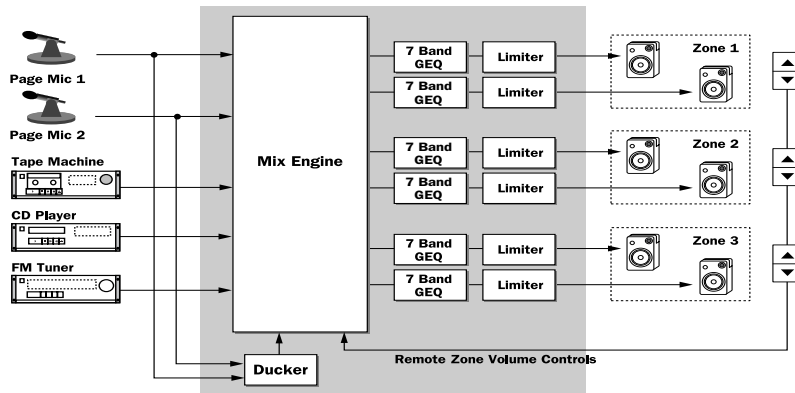

**ZONE PAGING  
WITH BACKGROUND MUSIC**

**BASIC DR66 USING PALETTE 1**

**THEME PUB/KARAOKE BAR**

**DR66 WITH DSPx EXPANDER  
USING PALETTES 4 and 18**

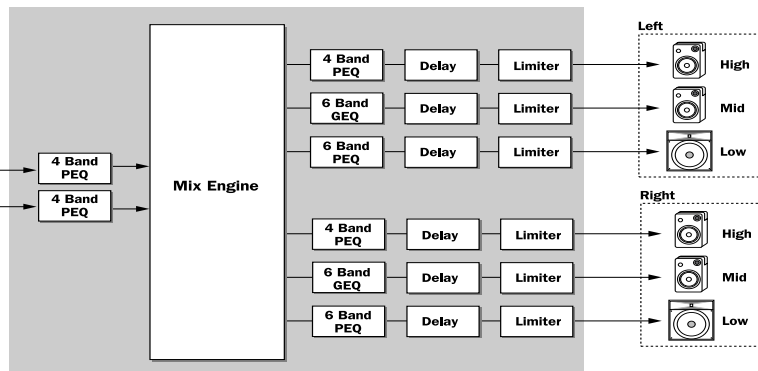
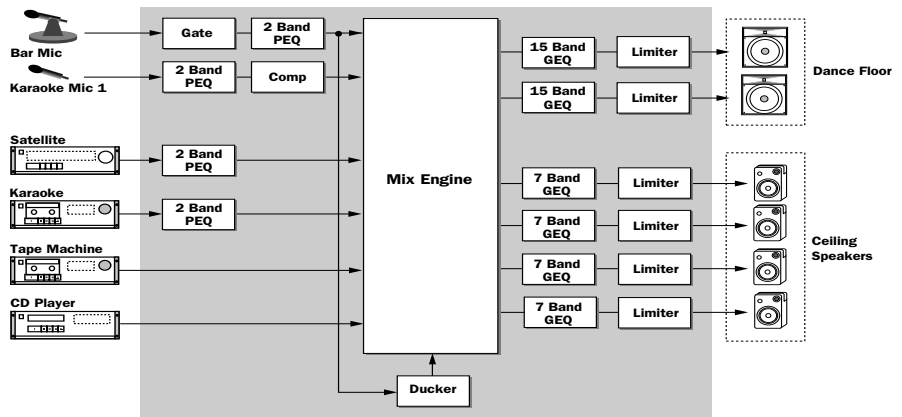

**SOUND  
REINFORCEMENT**

**DR66 WITH DSPx DELAY  
OPTION USING PALETTE 7**

**Resource Notes**

**GEQ** Graphic Equalizer available in 7, 15 & 31 Band configurations. **PEQ** Parametric Equaliser available in 2, 4, 6 Band configurations. **GATE** Noise Gate with controls for Attack, Release, Hold, Threshold and Depth. **COMP** Compressor with controls for Threshold, Ratio, Soft Knee, Attack/Release & Make-up gain.

PALETTE	RESOURCE	QTY
1	7 BAND GEQ	8
2	15 BAND GEQ	4
3	31 BAND GEQ	2
4	7 BAND GEQ	4
	15 BAND GEQ	2
5	15 BAND PEQ	10
6	4 BAND PEQ	8
	6 BAND PEQ	4
7	4 BAND PEQ	4
	6 BAND PEQ	4
8	2 BAND PEQ	6
	4 BAND PEQ	4
	6 BAND PEQ	2
9	15 BAND GEQ	2
	4 BAND PEQ	4
10	15 BAND GEQ	2
	4 BAND PEQ	8
11	7 BAND GEQ	4
	4 BAND PEQ	4

PALETTE	RESOURCE	QTY
12	7 BAND GEQ	4
	6 BAND PEQ	2
13	7 BAND GEQ	2
	4 BAND GEQ	4
	6 BAND PEQ	2
14	COMP	8
15	COMP	4
	4 BAND PEQ	4
16	COMP	4
	2 BAND PEQ	8
17	COMP	5
	GATE	5
18	COMP	4
	GATE	4
	2 BAND PEQ	4
19	GATE	8
	2 BAND PEQ	8
20	GATE	6
	4 BAND PEQ	6

**OTHER TYPICAL APPLICATIONS**

- Hotels
- Conference Centres
- Houses of Worship
- Theme Parks
- Stadia
- Distance Learning Suites
- Law Courts
- Installed public address
- Stage monitor processor and more...



## DR66 SPECIFICATIONS

0dBu = 0.775 VOLTS RMS    0dBV = 1 VOLT RMS    0dBFS

INPUTS		CONNECTOR	IMPEDANCE	GAIN
MIC IN	X2 XLR	PIN2+,3-	BALANCED	VARIABLE 12 TO 55dB
			PAD SELECTED	VARIABLE -10 TO 33dB
LINE IN	X4 DUAL RCA		UNBALANCED	LINK SELECTABLE -8dB TO +4DBU
			PHONO A&B MONO-SUMMED	
OUTPUTS				
OUTPUT	X6 XLR	PIN2+,3-	BALANCED	LINK SELECTABLE -8dB TO +4dBU
OTHER				
RS-232	X1	9 WAY D FEMALE	56KBAUD	
REMOTE SWITCH	X1	25 WAY D FEMALE		
	SWITCH INPUTS	X12	OPTO-ISOLATED TO 2.5kV	
	SWITCH OUTPUTS	X4	@10mA OPTO-ISOLATED TO 2.5kV	
DC POWER BACKUP		+24V (+/-15%) @ 1A		

INTERNAL HEADROOM	+12dBu	AC POWER REQUIREMENTS	FACTORY WIRED FOR 100, 120, 220, 230V AC
MAXIMUM OUTPUT LEVEL	+16dBu INTO 600 ohms		50/60Hz MAINS INPUT
FREQUENCY RESPONSE	+/-1dB 20Hz TO 20kHz		FUSE T315mA (220V - 240V AC)
DISTORTION	THD BETTER THAN 0.004% @ 1kHz		T630mA (100 - 120V AC)
CROSSTALK	INTERCHANNEL > -80dB AT 1kHz	DC POWER BACKUP	EXTERNAL DC POWER SUPPLY INPUT
NOISE 22Hz - 22kHz	MIC EIN -128dB (150 ohms source)		NOMINAL +24V DC (+/- 15%)
	LINE PREAMP AT 0dB GAIN -90dBu		FUSE 2A (INTERNAL)
	MIX NOISE (ALL ROUTED) > -80dBu		
MAX DYNAMIC RANGE	92dB	DIMENSIONS	486 X 380 X 41 mm
PANEL METERS	2 COLOUR: RED: PEAK -6dB dBFS GREEN: SIGNAL -42dB dBFS	UNPACKED WEIGHT	6.5kg
PHANTOM POWER	+18V, INTERNAL JUMPER LINKS	PACKED WEIGHT	7kg
POWER REQUIREMENTS	50/60Hz 25W MAX	ADC	20-BIT FS X 128
	MAINS VOLTAGE SET FOR LOCAL REQUIREMENTS	DAC	20-BIT FS X 128
POWER SUPPLY	INTERNAL REGULATED HYBRID SWITCH MODE/LINEAR	PROCESSING	2 X MOTOROLA 56002 24-BIT FIXED POINT
POWER CONSUMPTION	25VA MAX	SAMPLING FREQUENCY	48kHz

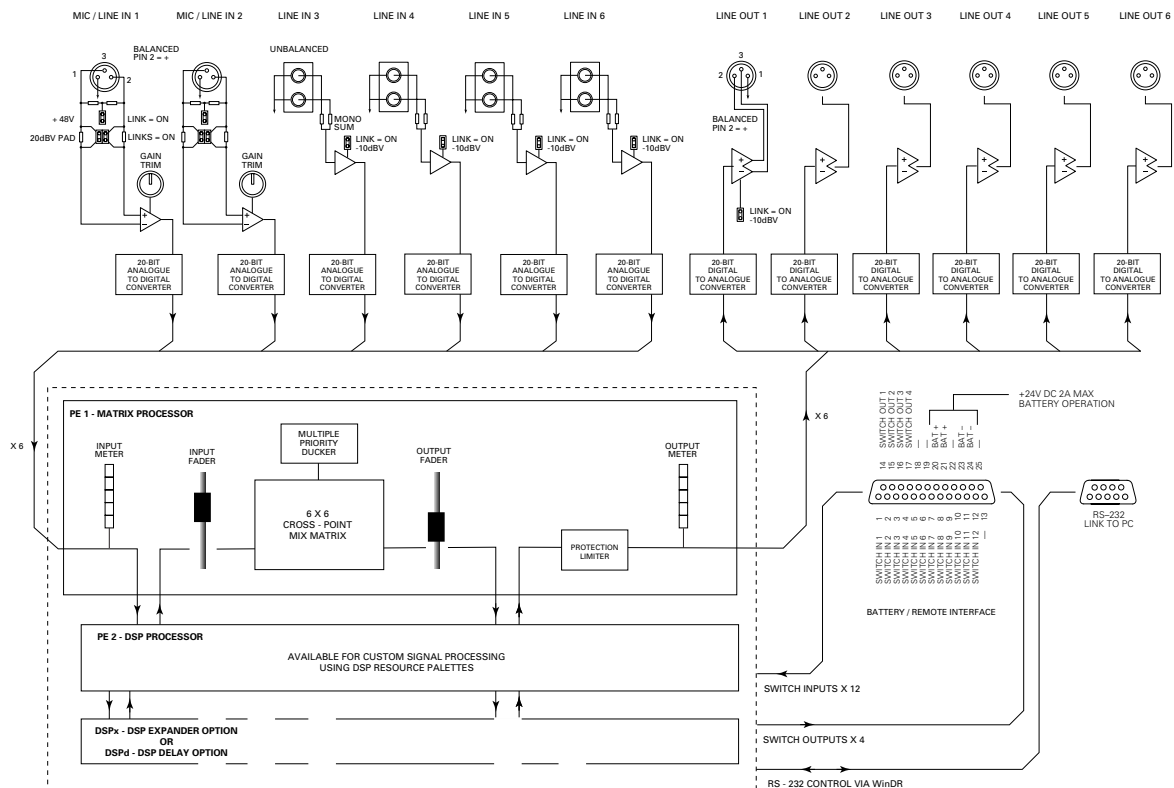

**ALLEN & HEATH** Kernick Industrial Estate, Penryn, Cornwall TR10 9LU.  
**Tel: (+44) 01326 372070** Fax: (+44) 01326 377097  
<http://www.allen-heath.com>

Allen & Heath reserve the right to improve or otherwise alter any information supplied in this document or any other documentation supplied hereafter



**CE** The DR66 complies with the European Directives for Electromagnetic Compatibility 89/336/EEC & 92/31/EEC

**H** A Harman International Company