



Exterior PixLine™ Family User Manual



Dimensions

PixLine 10

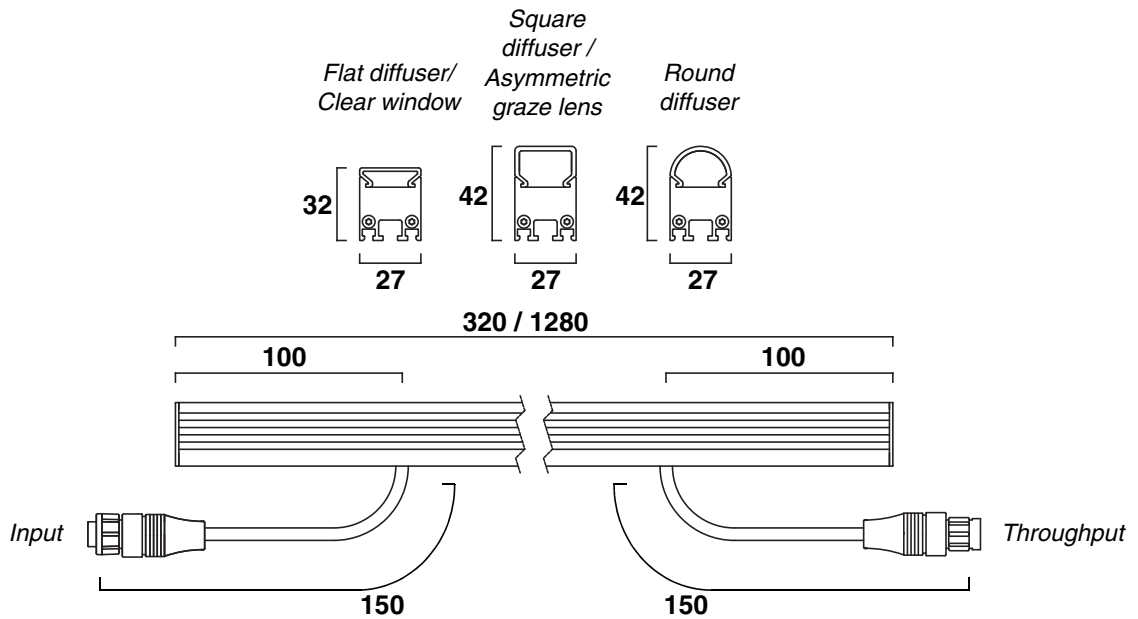

PixLine 10 mounting profile

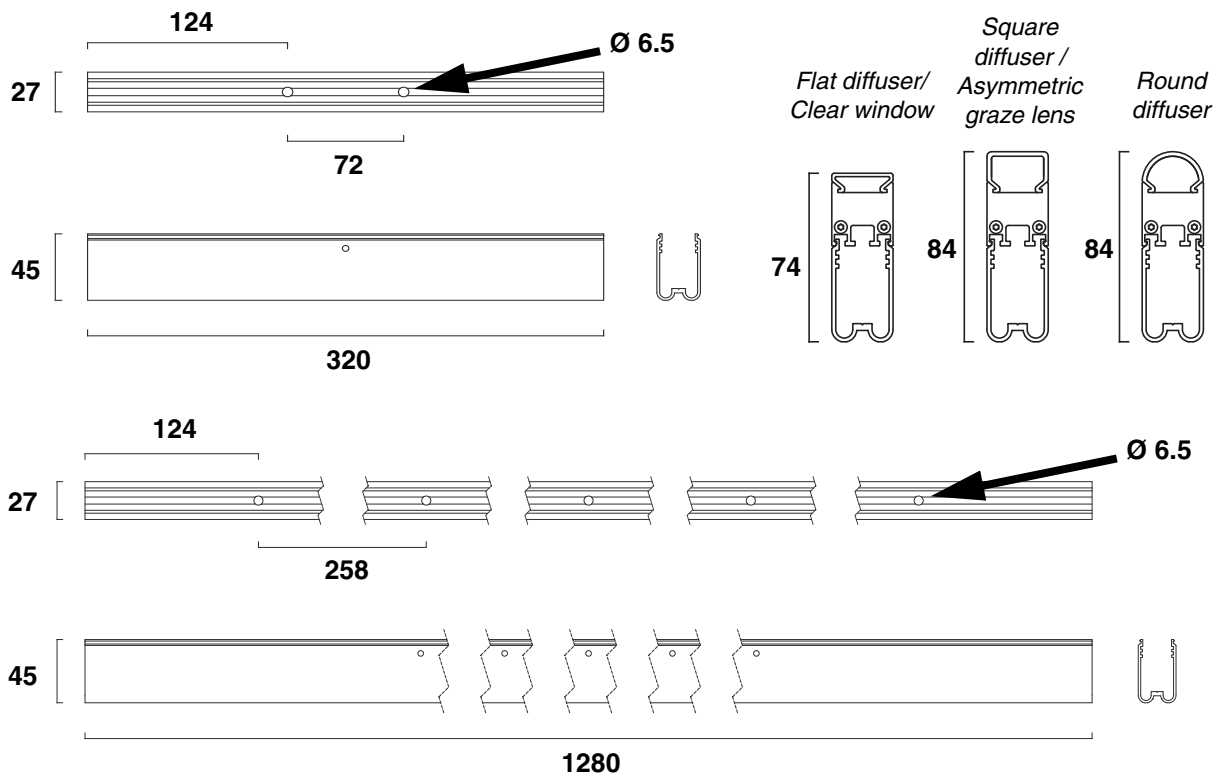

All dimensions are in millimeters

© 2015-2017 Martin Professional ApS. Information subject to change without notice. Martin Professional™ and all affiliated companies disclaim liability for any injury, damage, direct or indirect loss, consequential or economic loss or any other loss occasioned by the use of, inability to use or reliance on the information contained in this document. Martin™, Harman™ and all other trademarks in this document pertaining to services or products by Martin Professional™ or its affiliates and subsidiaries are registered as the property of Harman International Industries. Martin Exterior PixLine products are covered by patent application EP 15165618.8 and/or one or more other intellectual property rights, including one or more intellectual property rights listed on www.martin.com/ipr

PixLine 20, PixLine 40

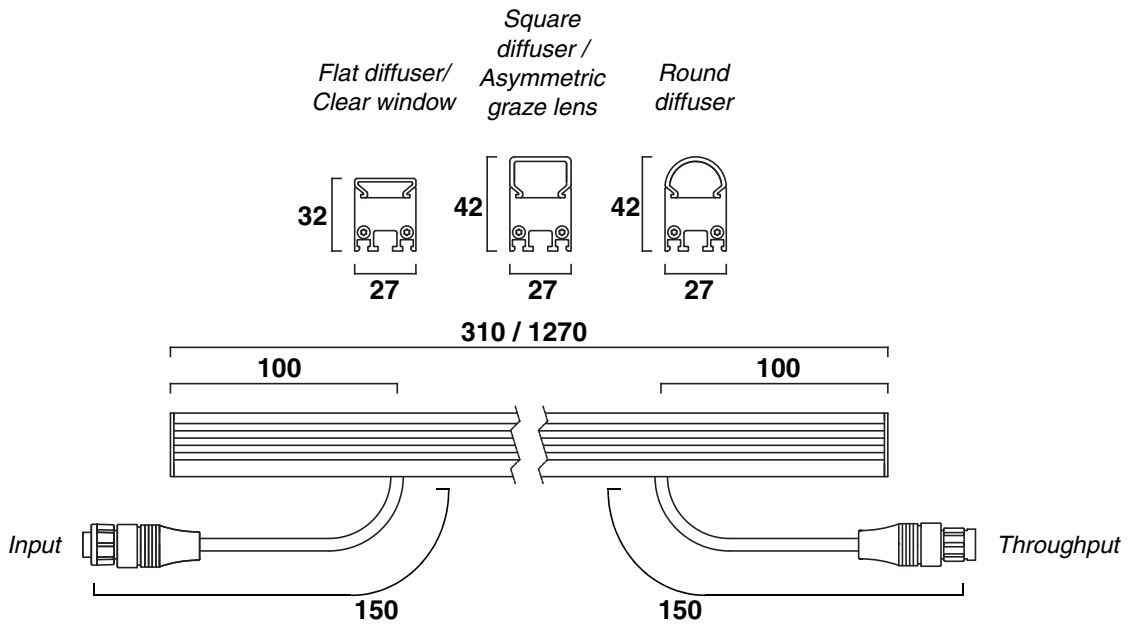

PixLine 20, PixLine 40 mounting profile

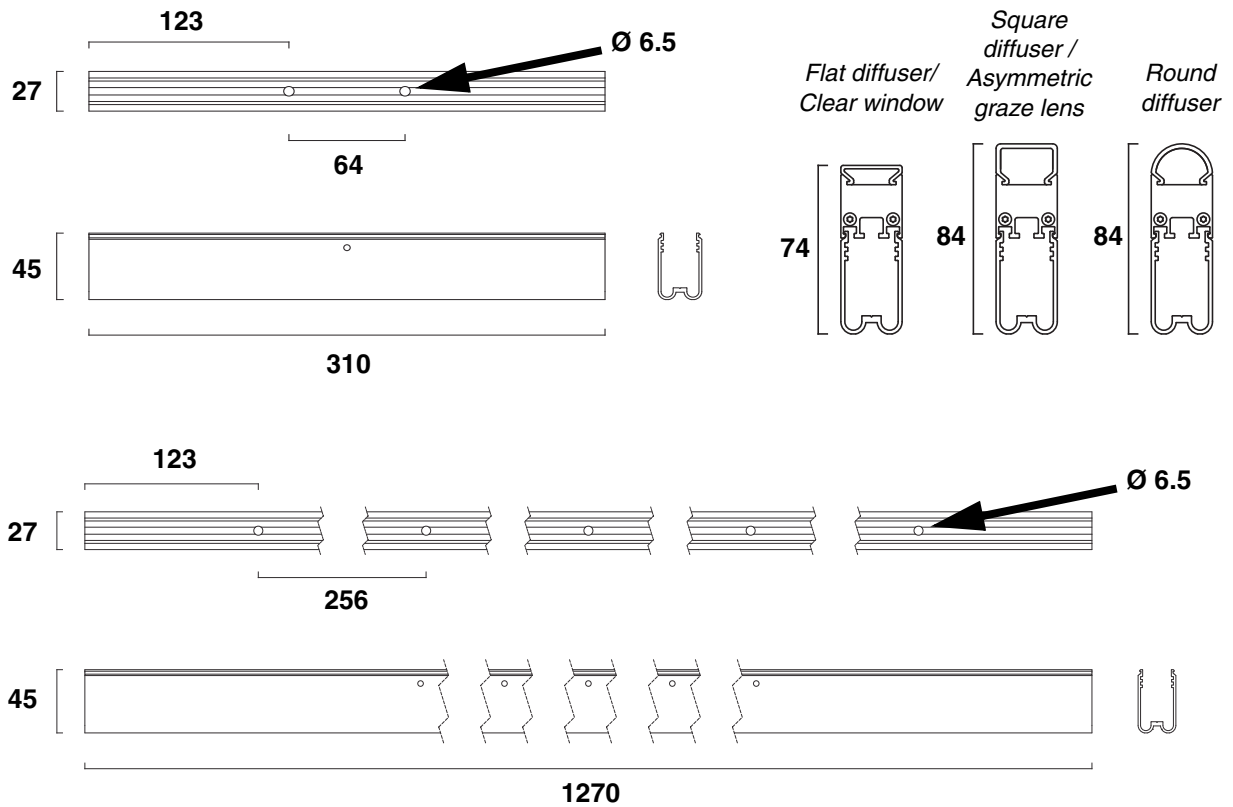

All dimensions are in millimeters

Contents

Dimensions	2
Safety information	5
Introduction	10
Precautions to avoid damage	10
Exterior PixLine™ overview	11
Physical installation	12
Avoiding damage when installing	12
Installing using mounting profile	14
Installing directly on a surface or structure	16
System installation	17
Installing a P3 system	17
Installing a DMX-controlled system	19
System setup	24
Pixels and segments	24
Setting up for P3 display	24
Setting up for DMX control	24
RDM	26
Using the Exterior PixLine	27
P3 display	27
DMX control	27
Magnetic 'control button'	27
Service and maintenance	29
Cleaning	29
Condensation and pressure relief valve	29
LED performance	29
Installing new software	30
Troubleshooting	31
DMX protocols	32
RGB Mode	32
Basic Mode	32
Segment Mode	33
Pixel Mode	34
Pre-programmed FX	35
Specifications	36

Safety information



WARNING!

Read the safety precautions in this section before installing, powering, operating or servicing this product.

The following symbols are used to identify important safety information on the product and in this document:



Warning!
Safety hazard.
Risk of severe
injury or
death.



Warning!
Hazardous
voltage. Risk
of severe or
lethal electric
shock.



Warning!
Fire hazard.



Warning!
Refer to user
manual.



Warning!

- **Read this user manual before installing and operating the Martin Exterior PixLine™. Keep this manual for future reference.**
- **Follow the safety precautions given in this user manual and in the manuals of all the devices you connect to it. Observe all warnings given in manuals and printed on devices. Make sure that everyone who is involved in working on or using the Exterior PixLine has read and understood these safety precautions and warnings.**
- **Install, connect, operate and service devices only as described in this manual and in connected devices' manuals and only in accordance with local laws and regulations. All Martin™ manuals are supplied with devices and are also available for download from www.martin.com.**
- **The Exterior PixLine is not for household use. It presents risks of severe injury or death due to fire and burn hazards, electric shock and falls. It must be installed by qualified technicians only.**
- **The Exterior PixLine does not have user-serviceable parts. Refer any operation not described in this manual to Martin™ Global Service or Martin™ authorized service agents.**



If you have any questions about how to operate the Exterior PixLine safely, please contact your Martin™ supplier or call the Martin™ 24-hour service hotline on +45 8740 0000, or in the USA on 1-888-tech-180.



PROTECTION FROM ELECTRIC SHOCK

- Read and respect the directions given in the user manuals of all the devices that you intend to connect to the Exterior PixLine, particularly the instructions, warnings and limits that apply to:
 - system layout,
 - connections to other devices,
 - specified cables,
 - maximum cable lengths, and
 - maximum number of devices that can be connected.
- Use only the cables specified in this manual and on the Martin™ website at www.martin.com to interconnect devices in the installation. If the specified cables are not long enough for an intended cable run, consult Martin™ for assistance in finding or creating a safe alternative solution.

- Provide a means of locking out AC mains power that allows power to the installation to be shut down and made impossible to reapply, even accidentally, during work on the installation.
- Shut down power to the installation during service and when it is not in use.
- Before applying power to the installation, check that all power distribution equipment and cables are in perfect condition and rated for the current requirements of all connected devices.
- Isolate the installation from power immediately if any product, power cable or power plug is in any way damaged, defective, or if it shows signs of overheating.
- Do not immerse the Exterior PixLine fixture in water.
- Do not allow the total length (including fixtures and cable) of a linked chain of Exterior PixLine fixtures to exceed 50 m (164 ft.) from the 48 VDC power source (Martin P3 PowerPort 1500™, Martin P3 PowerPort 1000 IP™, Martin™ IP66 PSU or other external PSU) to the last Exterior PixLine at the end of the chain.
- If you supply a chain of Exterior PixLine fixtures with DC power from a **generic 48 VDC external PSU** and the DC output used does not have constant overcurrent protection that limits current to 8 A, install an inline fuseholder with a 7.5 A or 8 A fuse on the circuit that you connect to that DC output.

Safety limits for connecting devices

Do not exceed the maximum safety limits given in the following tables.

Martin P3 PowerPort 1500™ safety limits

If you supply Exterior PixLine fixtures with DC power from a Martin P3 PowerPort 1500™:

- Do not connect more than one chain of fixtures to one DC output on the P3 PowerPort 1500™. Since the P3 PowerPort 1500™ has four DC outputs, you can connect a maximum of four chains of fixtures to one P3 PowerPort 1500™.
- Do not exceed the maximum total length of fixtures (including standard and custom lengths) that you can include in one chain (see Table 1).
- Do not exceed a maximum total length of 50 m (164 ft.) for a chain, including fixtures and cable, measured from the P3 PowerPort 1500™ to the end of the chain (see Table 1).

Type of fixture in chain	Maximum total length of fixtures in chain	Maximum total length of chain (fixtures and cable)
Exterior PixLine 10	10 m	50 m
Exterior PixLine 20	20 m	50 m
Exterior PixLine 40	40 m	50 m

Table 1: Maximum length of Exterior PixLine fixtures and chain per P3 PowerPort 1500™ output

Besides the above limits, each output of a P3 PowerPort 1500™ can drive a maximum of 63 fixtures regardless of the length of the fixtures. This may affect the Exterior PixLine 40. If you are creating a chain containing Exterior PixLine 40 320 mm fixtures, you must stop and create a new chain if you reach 63 fixtures.

Martin P3 PowerPort 1000 IP™ safety limits

If you supply Exterior PixLine fixtures with DC power from an output on a Martin P3 PowerPort 1000 IP™:

- Do not connect more than one linked chain of Exterior PixLine fixtures to one DC output. Since the P3 PowerPort 1000 IP™ has four DC outputs, you can connect a maximum of four chains of fixtures to one P3 PowerPort 1000 IP™.
- Do not exceed the maximum total length of fixtures (including standard and custom lengths) that you can include in one chain given (see Table 2).
- Do not exceed a maximum total length of 50 m (164 ft.) for a chain, including fixtures and cable, measured from the P3 PowerPort 1000 IP™ to the end of the chain (see Table 2).

Type of fixture in chain	Maximum total length of fixtures in chain	Maximum total length of chain (fixtures and cable)
Exterior PixLine 10	7 m	50 m
Exterior PixLine 20	14 m	50 m
Exterior PixLine 40	27 m	50 m

Table 2: Maximum number of Exterior PixLine fixtures per P3 PowerPort 1000 IP™ output

Besides the above limits, each output of a P3 PowerPort 1000™ can drive a maximum of 63 fixtures regardless of the length of the fixtures. This may affect the Exterior PixLine 40. If you are creating a chain containing Exterior PixLine 40 320 mm fixtures, you must stop and create a new chain if you reach 63 fixtures.

Martin™ IP66 PSU safety limits

You can supply Exterior PixLine fixtures with DC power from a Martin™ IP66 PSU 240W external power supply unit (this unit was previously called the ‘Martin™ Tripix Power IP66’). If you use this unit to supply DC power:

- Do not connect more than one linked chain of Exterior PixLine fixtures to the DC power output of the Martin™ IP66 PSU.
- Do not exceed the maximum total length of fixtures (including standard and custom lengths) that you can include in one chain given (see Table 3).
- Do not exceed a maximum total length of 50 m (164 ft.) for a chain, including fixtures and cable, measured from the Martin™ IP66 PSU to the end of the chain (see Table 3).

Type of fixture in chain	Maximum total length of fixtures in chain	Maximum total length of chain (fixtures and cable)
Exterior PixLine 10	7 m	50 m
Exterior PixLine 20	14 m	50 m
Exterior PixLine 40	27 m	50 m

Table 3: Maximum number of Exterior PixLine fixtures per Martin™ IP66 PSU

Generic 48 VDC external PSU safety limits

If you supply a chain of Exterior PixLine fixtures with DC power from a **48 VDC external PSU (power supply unit) that you obtain yourself**, you must not exceed **the lowest** of these limits:

- Do not create a chain that will exceed the maximum power rating of the PSU output used to supply that chain with power (to find the power consumption of the chain, multiply the number of fixtures in the chain with the wattage per fixture according to Table 4).
- Do not exceed the maximum total length of fixtures and the maximum total length of cable that you can connect in one chain (see Table 4). Include the length of all standard and all custom fixtures when calculating the total length of fixtures.
- Do not create a chain with a total length of more than 50 m (164 ft.).

Each time you reach (a) the maximum total length of fixtures in one chain, or (b) 50 m (164 ft.) total length of the chain, or (c) the PSU output's maximum power rating – **whichever you reach first** – you must create a new chain of fixtures that is connected to a new 48 VDC power output.

Type of fixture in chain	Wattage per fixture	Maximum total length of fixtures in chain	Maximum total length of chain (fixtures and cable)
Exterior PixLine 10, 1280 mm	44 W		
Exterior PixLine 10, 320 mm	11 W	10 m	50 m
Exterior PixLine 10, custom lengths	Allow 36 W per meter		
Exterior PixLine 20, 1280 mm	22 W		
Exterior PixLine 20, 320 mm	5.5 W	20 m	50 m
Exterior PixLine 20, custom lengths	Allow 18 W per meter		
Exterior PixLine 40, 1280 mm	11 W		
Exterior PixLine 40, 320 mm	3 W	40 m	50 m
Exterior PixLine 40, custom lengths	Allow 9 W per meter		

Table 4: Maximum number of Exterior PixLine fixtures per 48 VDC external PSU (provided that PSU rating in watts is not exceeded).



PROTECTION FROM BURNS AND FIRE

- The Exterior PixLine is cooled by convection. Ensure sufficient ventilation by providing free airflow and keep a minimum distance of 10 mm (0.4 in.) between the fixture and any surfaces or objects around it.
- Do not operate the Exterior PixLine if the ambient temperature (T_a) around the fixture exceeds 55° C (131° F).
- Do not modify the Exterior PixLine in any way not described in this manual or install other than genuine Martin™ parts. Use only accessories approved by Martin™.



PROTECTION FROM INJURY

- Read carefully the chapter “Physical installation” on page 12 and respect the limits and instructions given in that chapter.
- Ensure that the installation hardware and supporting surface or structure can hold at least 10 times the weight of all the devices they support.
- Block access below the work area and work from a stable platform whenever installing, servicing or moving the Exterior PixLine.
- Make sure that all items are securely installed, taking into consideration all possible environmental conditions including temperature variation and wind. Make sure that it is impossible for items to fall, causing injury or damage.
- Use grade 8.8 strength fasteners that are suitable for their purpose and the installation environment.
- Fasten 310 mm and 320 mm fixtures to the supporting surface or structure with a minimum of two fasteners (screws, bolts, etc.) per fixture. Fasten 1270 mm and 1280 mm fixtures to the supporting surface or structure with a minimum of five fasteners (screws, bolts, etc.) per fixture.
- Either use self-locking nuts or use lockwashers with standard nuts on all bolts.
- Use a torque driver when tightening bolts on mounting profile locks and tighten to a torque of 1 Nm (0.75 ft.-lbs.).

- In all installations where fixtures may be exposed to temperature variation of +/- 5° C (+/- 9° F) or more, allow as described in this manual a 10 mm gap between fixtures to allow for thermal expansion. This requirement applies in all indoor locations that are not maintained at constant temperature and in all outdoor locations.

Introduction

Thank you for selecting a product from the Martin Exterior PixLine™ family. These compact LED-based display fixtures are designed to integrate into a Martin P3™ video system, where they can display video from a variety of sources. They can also be controlled using DMX. Use of an RDM-compliant DMX controller such as the Martin M-PC™ allows two-way communication and remote management of Exterior PixLine fixtures from the controller.

The Exterior PixLine combines flexibility and simplicity with high-quality video display capabilities. Multiple Exterior PixLine fixtures can be combined in ways that give exceptional creative potential. Fixtures are supplied in a range of optical configurations including left and right side wallwasher versions designed for illuminating surfaces. A hybrid (power and data) cabling system allows Exterior PixLine fixtures to be daisy-chained for easy setup and minimal cabling.

The Exterior PixLine consists of a linear array of LEDs encapsulated in resin in an aluminum profile with a diffuser or other front cover that is permanently sealed onto the profile to give a rugged IP66-rated fixture. It offers the following features:

- IP66-rated fixtures and connectors
- Fast, flexible mounting options
- Clear anodized as standard, custom RAL colors available by special order
- Range of optical variants: clear front, flat diffuser, round diffuser, square diffuser and graze (asymmetric wallwasher) lens options
- Three pixel pitch (LED center-to-center distance) options: 10, 20 or 40 mm
- Short 310/320 mm (12.2/12.6 in.) and long 1270/1280 mm (50.0/50.4 in.) models
- Individually controllable pixels
- High-quality 16-bit per color RGB image processing technology
- Pixel-level brightness and color calibration for optimal image quality
- P3 and DMX control with automatic protocol detection
- Intuitive pixel mapping and addressing using a Martin P3™ system controller
- Single hybrid cable transmits both power and data
- External power and data processor (Martin P3 PowerPort 1500™ or P3 PowerPort 1000 IP™) and simple cabling system.

Custom lengths from 300 mm to 2000 mm can be made to special order. Please consult your Martin™ supplier for details.

For detailed dimensions drawings in various file formats of all the products in the Exterior PixLine family, please see the Exterior PixLine Product Support pages on the Martin™ website at www.martin.com

Martin™ user documentation is supplied with products and available for download from www.martin.com, where you can also find the latest specifications, firmware updates and support information for all Martin™ products.

At Martin™ we welcome input from users. Comments or suggestions regarding this manual can be e-mailed to service@martin.dk or posted to: User Documentation, Martin Professional ApS, Olof Palmes Allé 18, DK-8200 Aarhus N, Denmark.

Precautions to avoid damage

Important! To get the best out of the Exterior PixLine and avoid causing damage that is not covered by the product warranty, read the following information carefully. Make sure that everyone who is involved in installing, working on or using the Exterior PixLine has read and understood this information.

Cleaning

Excessive dirt buildup causes overheating and may damage the product. Damage caused by inadequate cleaning is not covered by the product warranty.

Operating temperature precautions

- Operating the Exterior PixLine in an ambient temperature that exceeds the specified maximum of 55° C (131° F) for showing average video content may reduce the lifetime of the product.
- Exterior PixLine fixtures have an internal thermal sensor. If the sensor measures excessive temperature, a thermal protection cutout shuts down the fixture. The fixture will not function normally again until the temperature has fallen to a safe level.
- When using a Martin P3™ System Controller you can enable "thermal throttling" functionality. This feature gradually dims fixtures if they get hot, avoiding full thermal shutdowns.

Sealing unused connectors with blanking caps

Blanking caps for female BBD connectors can be ordered separately in sets of 10 (see "Connectors" on page 38). Install blanking caps on all unused female BBD connectors to seal them against water and dirt, otherwise short-circuits and damage may occur.

Exterior PixLine™ overview

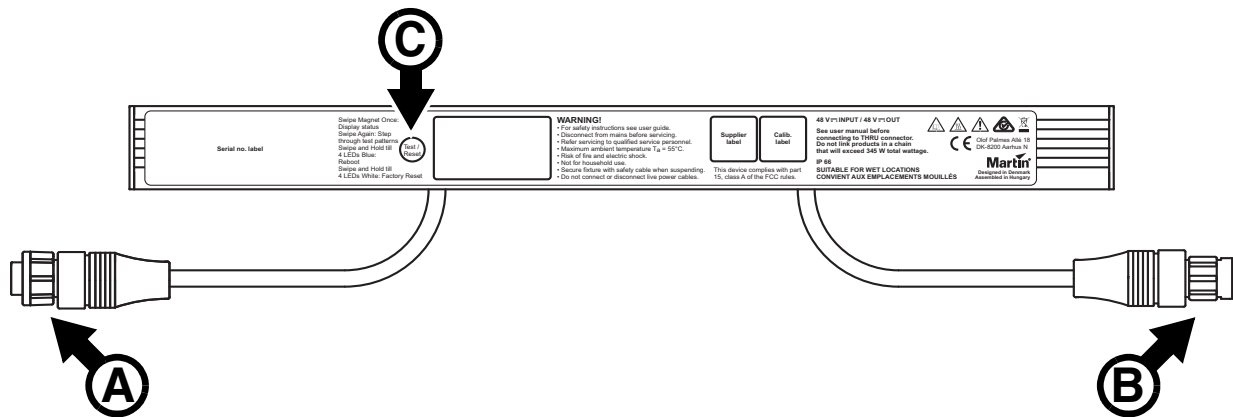

320 mm fixture illustrated

A - 48 VDC power + video data male BBD-type input connector

B - 48 VDC power + video data female BBD-type output (thru) connector

C - Magnetic control sensor (encased inside fixture) – can be activated using accessory tool

Figure 1: Overview

Physical installation



Warning! Read “Safety information” on page 5 before installing the Exterior PixLine and read all of this ‘Physical installation’ chapter before starting work.

Warning! Thermal expansion can create a safety hazard and cause damage if fixtures are installed end-to-end without a gap between them and exposed to temperature variations of $\pm 5^{\circ}\text{C}$ ($\pm 9^{\circ}\text{F}$) or more. In outdoor locations and all locations where significant temperature variations are present, all Exterior PixLine mounting profiles and fixtures must be installed with a 10 mm gap between the ends of fixtures to allow for thermal expansion.

You can install the Exterior PixLine on a surface or structure using two methods:

- You can fasten Exterior PixLine mounting profile into position first and then secure fixtures on the profile. This option lets you conceal up to two cable runs inside the profile and gives a clean appearance.
- You can bolt Exterior PixLine fixtures directly to a structure or surface, using the channels in the base of fixtures as tracks to hold M6 bolt heads.

The Exterior PixLine can be installed in any orientation.

Allow free airflow and 10 mm (0.4 in.) minimum clearance around the fixture. You must also allow clearance around mounting locks for access with a wrench or Allen key (see Figure 4 on page 15).

The Exterior PixLine is designed to withstand water projections such as rainfall and low-pressure water jets and can be installed outdoors, but do not submerge it and do not install it in a location where water can build up around the fixture. If necessary, provide drainage at the installation location.

Optimizing optical characteristics

If you install multiple fixtures that run parallel at the same angle, install the fixtures with their male connectors at the same end, running extension cables between female and male connectors if necessary (see “Cables” on page 38). This will give the most even optical characteristics.

Installing Exterior PixLine fixtures vertically in columns will give the most even light output when viewing the installation from the side. There is only a minor difference compared to fixtures installed horizontally in rows, however, and any unevenness in horizontal fixtures will only be visible when they are viewed from the side.

Avoiding damage when installing

Avoid causing damage that is not covered by the product warranty by following these instructions carefully.

Keeping connections dry

Moisture on connectors can cause short circuits and damage to products. Check that all connectors are perfectly dry before you connect them. Do not install the Exterior PixLine during wet weather conditions or if condensation is visible on any surfaces.

Avoiding shocks and stress

Do not expose the Exterior PixLine to physical shocks (by dropping onto a hard surface, for example).

Do not apply pressure to or otherwise stress diffusers or lenses.

Do not stress cables (by bending them sharply, for example). Protect cables from sharp edges.

Protection from corrosion

Fixtures and profiles are manufactured in corrosion-resistant anodized aluminum, but you must take precautions to avoid direct contact between aluminum and other metals, as this can cause galvanic corrosion:

- Use an electrically insulating material (such as rubber or plastic) or a coating between aluminum fixtures or mounting profiles and any other metal.
- Use a non-conductive coating such as Delta Seal on fasteners (screws, bolts, washers, etc.) where they come into contact with fixtures or mounting profiles.

Thermal expansion, end-to-end gaps and pixel pitch

In indoor locations at room temperature and similar locations where Exterior PixLine fixtures are subject to minimal temperature variations only, it is not necessary to leave end-to-end gaps between Exterior PixLine 10 fixtures to allow for thermal expansion, but you must still leave a gap of approximately 10 mm between Exterior PixLine 20 and Exterior PixLine 40 fixtures if you want to maintain a uniform pixel pitch. If maintaining exact pixel pitch is important, adjust the position of fixtures until the end-to-end gaps give the most even pixel pitch.

To avoid damage to fixtures from thermal expansion and obtain the best visual results, follow these instructions carefully:

Exterior PixLine 20 and 40

Exterior PixLine 20 and Exterior PixLine 40 standard length fixtures are 310 mm or 1270 mm long.

- **In all locations**, install standard and custom length fixtures with an end-to-end gap of approximately 10 mm between them. This gap maintains even pixel pitch in a line of fixtures and allows for thermal expansion.

Exterior PixLine 10

Exterior PixLine 10 standard length fixtures are 320 mm or 1280 mm long.

- **In all locations where there may be temperature variations of +/- 5° C (+/- 9° F) or more**, install standard and custom length Exterior PixLine 10 fixtures with an end-to-end gap of approximately 10 mm between them. This means that there will be a one-pixel gap between Exterior PixLine 10 fixtures.
- **In indoor locations that remain at constant temperature**, you can install fixtures with no end-to-end gap between them. This will maintain a constant 10 mm pixel pitch across two or more fixtures and avoid the one-pixel gap between fixtures.

Pressure relief valve

The air inside fixtures expands and contracts as they warm up and cool down. See Figure 2. To equalize the resulting pressure variations without allowing water into the fixture, the Exterior PixLine features a pressure relief valve (arrowed) with a Gore-Tex membrane.

Do not allow pressure relief valves to become blocked.

If a valve is not in perfect condition, do not operate the fixture. Contact Martin™ Service for valve replacement.

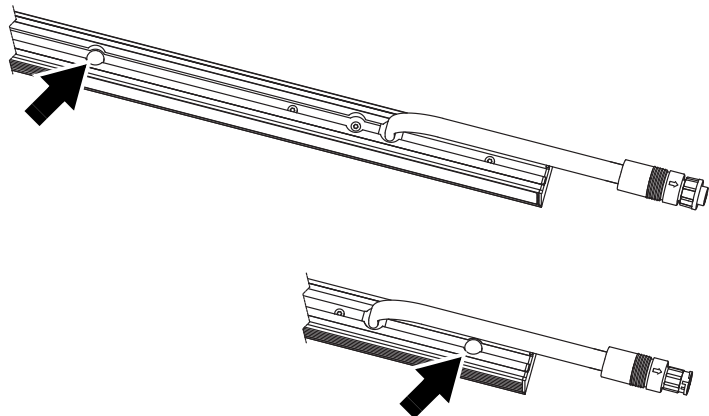

Figure 2: Pressure relief valves

Installing using mounting profile

To simplify installation on a surface, you can install Exterior PixLine mounting profiles on the surface and then fasten fixtures into the profiles. The profiles are deep enough to conceal a total of three cable runs.

See Figure 3. To install an Exterior PixLine fixture **A** on a surface using the mounting profile **B** designed for the product:

1. Make sure that you have the same length of mounting profile as the length of the fixtures.
2. If necessary, allow a 10 mm end-to-end gap between profiles (see “Thermal expansion, end-to-end gaps and pixel pitch” on page 13).
3. With reference to “Dimensions” on page 2, mark up the mounting surface or structure and prepare holes to accept the fasteners that you will pass through the mounting profiles in the installation. Insert screw plugs if necessary for a secure installation.
4. Obtain grade 8.8 strength 6 mm diameter fasteners (screws, screwbolts, bolts, etc.) that are suitable for the application. You will need one fastener per 6.5 mm diameter hole in the mounting profile. Apply an electrically insulating coating such as Delta Seal to fasteners to prevent contact between the aluminum profile and the fasteners. If necessary, use electrically insulating material to prevent contact between the aluminum profile and any other metals when the profile is installed. Fasten each mounting profile to the surface or structure.
5. There is space for you to conceal up to two cable runs in the mounting profile.

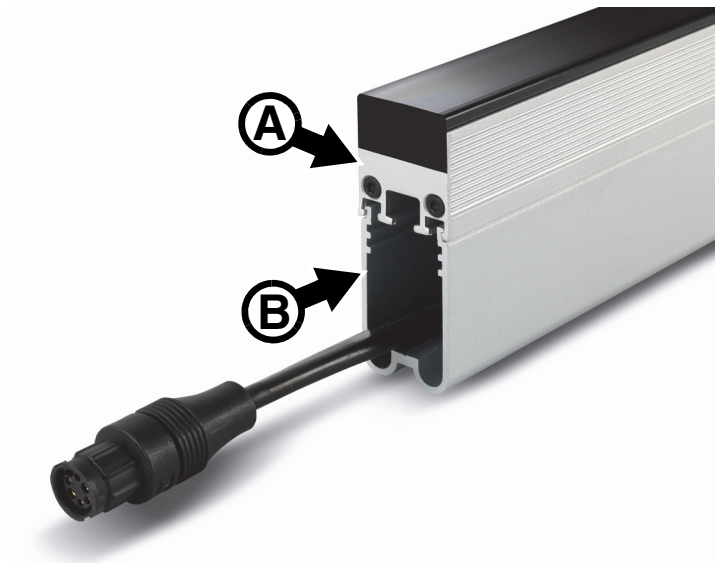

Figure 3: Mounting profile: end view

- See Figure 4. Prepare one mounting profile lock **C** per 310/320 mm fixture or minimum three mounting profile locks per 1270/1280 mm fixture. Apply a small quantity of Loctite 243 to the threads of the lock bolts **D**. Place each lock **C** in position so that it engages with the grooves in the profile as shown at **E** and tighten the bolt **D** finger-tight only.

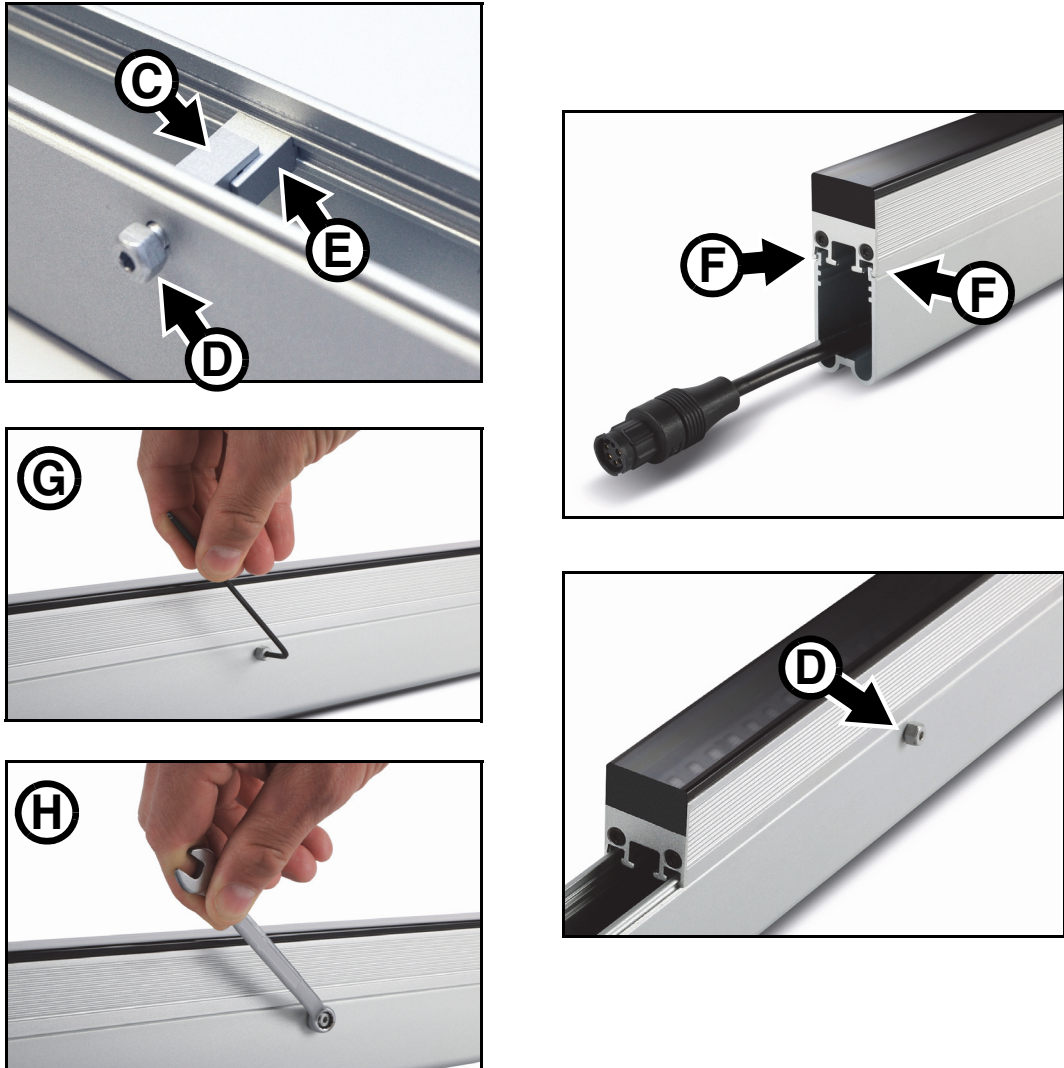

Figure 4: Mounting Profile Lock

- Connect the fixture to the input cable or the previous fixture on the link, ensuring that connections are correctly fastened together, then position the fixture on the profile so that the lips on the fixture engage in the channels in the profile as shown at **F**.
- Tighten the lock bolt on each mounting profile lock to secure the fixture in the profile. The bolt accepts a 2.5 mm Allen key **G** or a 7 mm wrench **H**. Tighten the bolt to a torque of 1 Nm (0.75 ft.-lbs.) using a torque driver or torque wrench. When you have tightened the bolt, check that the head of the bolt **D** sits flat against the mounting profile.
- Check that the fixture is held securely. If necessary, leave a 10 mm gap (see “Thermal expansion, end-to-end gaps and pixel pitch” on page 13) before you install the next fixture.

Installing directly on a surface or structure

You can install the Exterior PixLine directly on a surface or structure without using mounting profiles if you have access to the rear of the surface or structure so that you can fasten nuts onto mounting bolts.

To install an Exterior PixLine fixture directly on a structure using M6 bolts.

1. Obtain suitable M6 bolts and either self-locking nuts or nuts with lockwashers. Nuts and bolts must be grade 8.8 strength.
2. Apply a non-conductive coating such as Delta Seal to all parts of the bolts that will come into contact with the fixture.
3. With reference to “Dimensions” on page 2, prepare 6.5 mm diameter holes in the structure to take the ends of captive bolts in the track on the fixture. Position holes so that captive bolts will not interfere with cable entry and pressure relief valves when installed. Provide two holes for 310 mm and 320 mm fixtures. Provide five evenly spaced holes for 1270 mm and 1280 mm fixtures. In locations where fixtures will not be exposed to vibration or wind forces, you can use three evenly spaced holes.
4. See Figure 5. Slide the bolt heads into the track (arrowed) in the fixture either from the end of the fixture or through the cutouts provided in the track.
5. Pass the ends of the bolts through the holes in the structure and fasten the bolts using either self-locking nuts or nuts secured with locking washers. Tighten the nuts to a torque of 8 Nm.

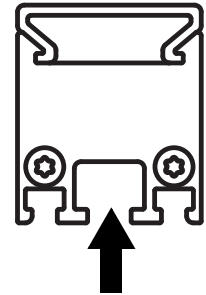

Figure 5: Track for M6 bolt

Custom length fixtures

Custom length Exterior PixLine fixtures are available to special order from Martin™. When installing a custom length fixture:

- Just as with standard length fixtures, allow for thermal expansion by leaving a 10 mm end-to-end gap between fixtures if you install in a location where the ambient temperature may vary.
- Use **all** the holes provided in mounting profiles for:
 - screwing the profile to a mounting surface or structure and
 - installing mounting profile locks.

System installation



Warning! Read “Safety information” on page 5 and “Precautions to avoid damage” on page 10 carefully before installing an Exterior PixLine™ system.

Warning! Connect the Exterior PixLine™ only to the devices and using only the Martin™ cables specified in this manual.

Warning! Do not exceed the maximum numbers of devices that can be connected in chains and maximum cable lengths specified in “Protection from electric shock” starting on page 5 and in the manuals of the other devices in the system.

The Exterior PixLine is designed to display either Martin P3™ video or DMX-controlled lighting effects. It automatically recognizes and responds to either a Martin P3™ or a DMX data signal. The next sections explain how to create an Exterior PixLine installation to display P3 video data or DMX-controlled lighting effects.

Installing a P3 system

See Figure 7 for an overview of the elements and layout of a Martin P3™ video display system.

To install a system that displays P3 video on Exterior PixLine fixtures, see the overview in Figure 7 and follow these directions:

1. Make sure that no devices in the installation can be connected to AC mains power until all installation work is complete.
2. Read “Safety information” on page 5 and “Precautions to avoid damage” on page 10.
3. Connect Exterior PixLine fixtures together in chains either directly using the fixtures’ cable tails and BBD connectors or by adding Martin™ hybrid cables with BBD connectors (see “Cables” on page 38).
Warning! Do not exceed the maximum total length of fixtures and total cable length per chain given in “Safety limits for connecting devices” on page 6.
4. Install a blanking cap (see “Cables” on page 38) on the output connector of the last fixture on each chain to protect from water, dirt etc.
5. Connect each chain of Exterior PixLine fixtures to one of the four 4-pin female XLR hybrid (48 VDC power + P3 data) outputs on a P3 PowerPort 1500™ using a Martin™ hybrid 4-pin male XLR to BBD adapter cable, P/N 91616046 (see Figure 6). Alternatively, connect each chain of Exterior PixLine fixtures to one of the 4 outputs on a P3 PowerPort 1000 IP™.

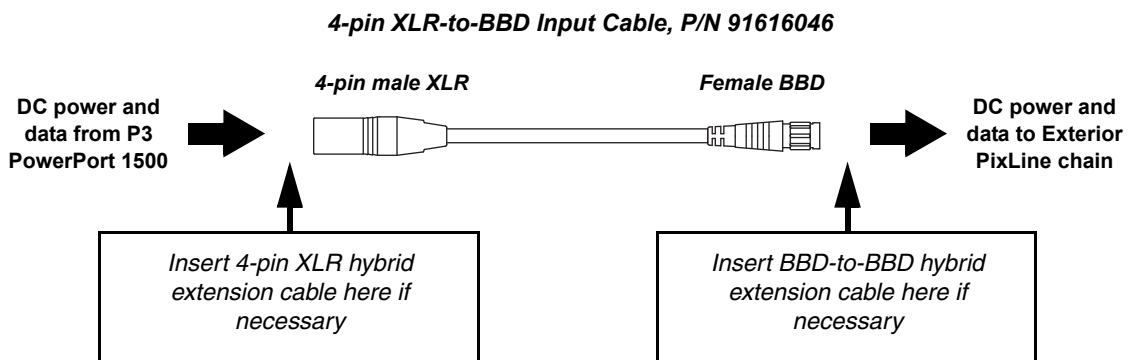
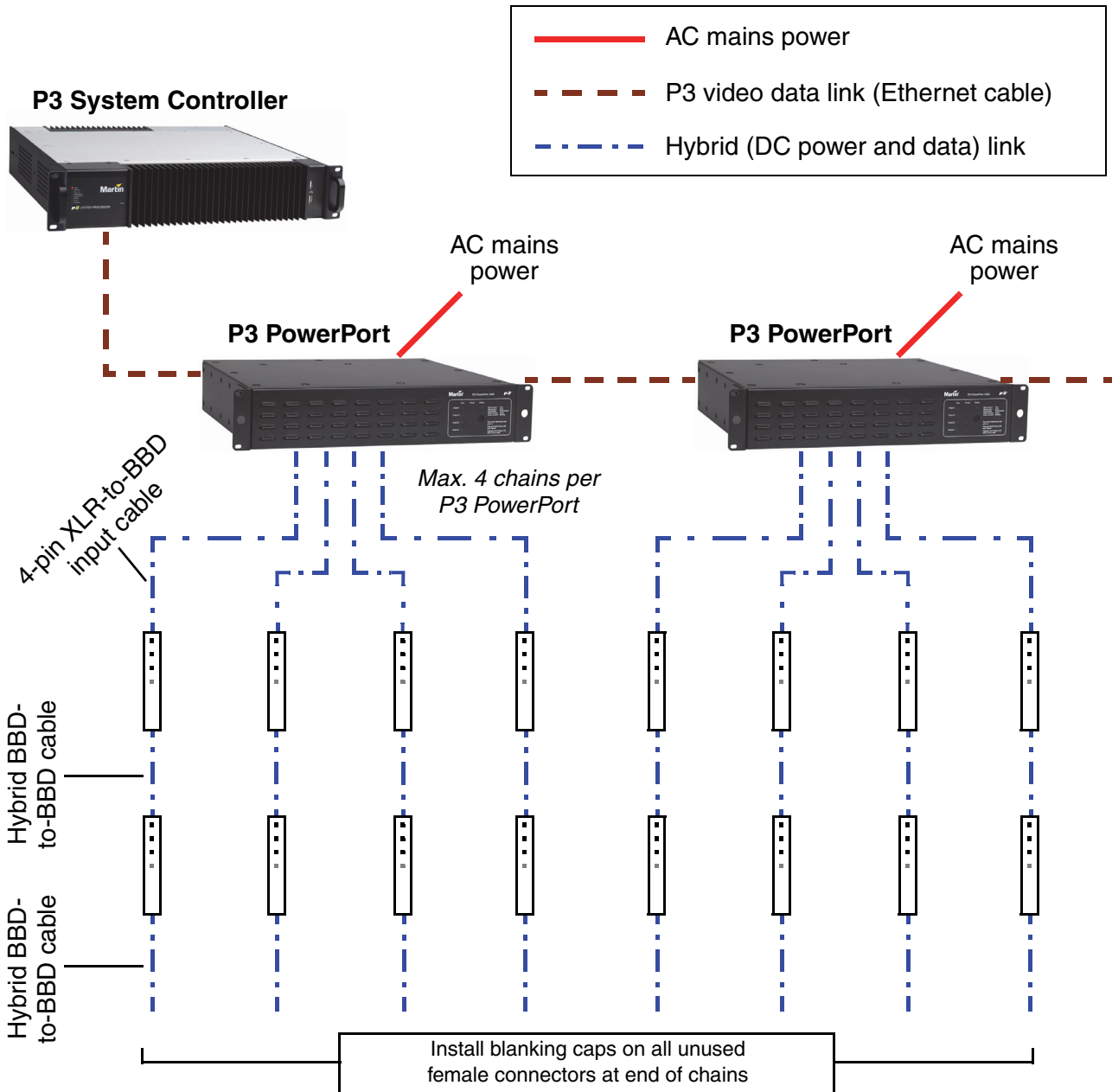

Figure 6: Power and P3 video data input

6. If necessary, add a BBD-to-BBD extension cable between the first fixture and the P3 PowerPort. Suitable extension cables are available from Martin™ in various lengths. See “Cables” on page 38.
7. Create a P3 video data link from a Martin P3™ system controller such as the P3-100™, P3-200™, P3-300™ or P3 PC™ to the P3 PowerPort 1500™ or P3 PowerPort 1000 IP™ (see the products’ user manuals for details).

8. It is possible to connect P3 PowerPort devices in daisy-chains in a P3 network, but if you are using multiple P3 PowerPorts in a fixed installation we recommend that you distribute the P3 signal by connecting an unmanaged Gigabit Ethernet switch to the P3 System Controller and then connecting each P3 PowerPort directly to the switch. This eliminates the risk of one P3 PowerPort signal failing and causing loss of signal to the P3 PowerPorts daisy-chained behind it.
 9. Connect the P3 PowerPort to AC mains power at 100 - 240 V, 50/60 Hz as described in its user manual.
 10. connect the P3 system controller to AC mains power and power the controller on.
- You can now configure the system at the P3 controller. See "System setup" on page 24.



 See "Safety limits for connecting devices" on page 6 before creating a chain

Figure 7: P3 system layout

Installing a DMX-controlled system

In a DMX-controlled system, an RDM-compliant DMX lighting controller sends a DMX control data signal over a DMX link to the installation, and then over the hybrid link to the Exterior PixLine fixtures.

The DMX link requires DMX cable. It can be maximum 300 m (1000 ft.) in length and must run in one single daisy-chain, but it can be extended or split into branches using an RDM-compliant amplifier/splitter such as the Martin RDM 5.5 Splitter™ (P/N 90758150). Alternatively, you can run the DMX signal from the controller over Ethernet cable using Art-Net protocol and convert it to a DMX-compliant signal with an Art-Net to DMX converter.

If you would like assistance with creating a DMX link, your Martin™ supplier will be glad to advise.

The number of Exterior PixLine fixtures that you can control on one DMX link is limited by the number of DMX channels the fixtures will use and the 512 DMX channels available in one DMX universe at the DMX controller. Each time you have used 512 channels, you must create a new DMX link that is connected to a new DMX universe on the controller. Note that this limit applies to the *DMX link*. The maximum safety limits that apply to the chain of fixtures and cable (see “Safety limits for connecting devices” on page 6) take priority and must be respected in all cases.

If you need to take the DMX signal from the end of a chain of Exterior PixLine fixtures, connect a DMX Lead-out Cable (see “Cables” on page 38) to the output connector of the last fixture on the chain. The Lead-Out Cable has a 5-pin female XLR connector with standard DMX pinout (pin 1 = shield, pin 2 = data cold/negative, pin 3 = data hot/positive, pins 4 and 5 are not used) that lets you draw off the DMX signal.

DC Power options in DMX installations

A DMX-controlled Exterior PixLine installation can be supplied with DC power from the Martin™ IP66 Power Supply Unit or from a generic external PSU (the Mean Well SP-480 48, for example).

The hardware and cables required are slightly different depending on which type of PSU you use to supply the installation with DC power. The two different types of installation are covered in the next two sections:

- If you are using a Martin™ IP66 PSU, see “Installing a DMX system using the Martin™ IP66 PSU” on page 20.
- If you are using a generic 48 VDC PSU, see “Installing a DMX system using a generic external 48 VDC PSU” on page 22.

Installing a DMX system using the Martin™ IP66 PSU

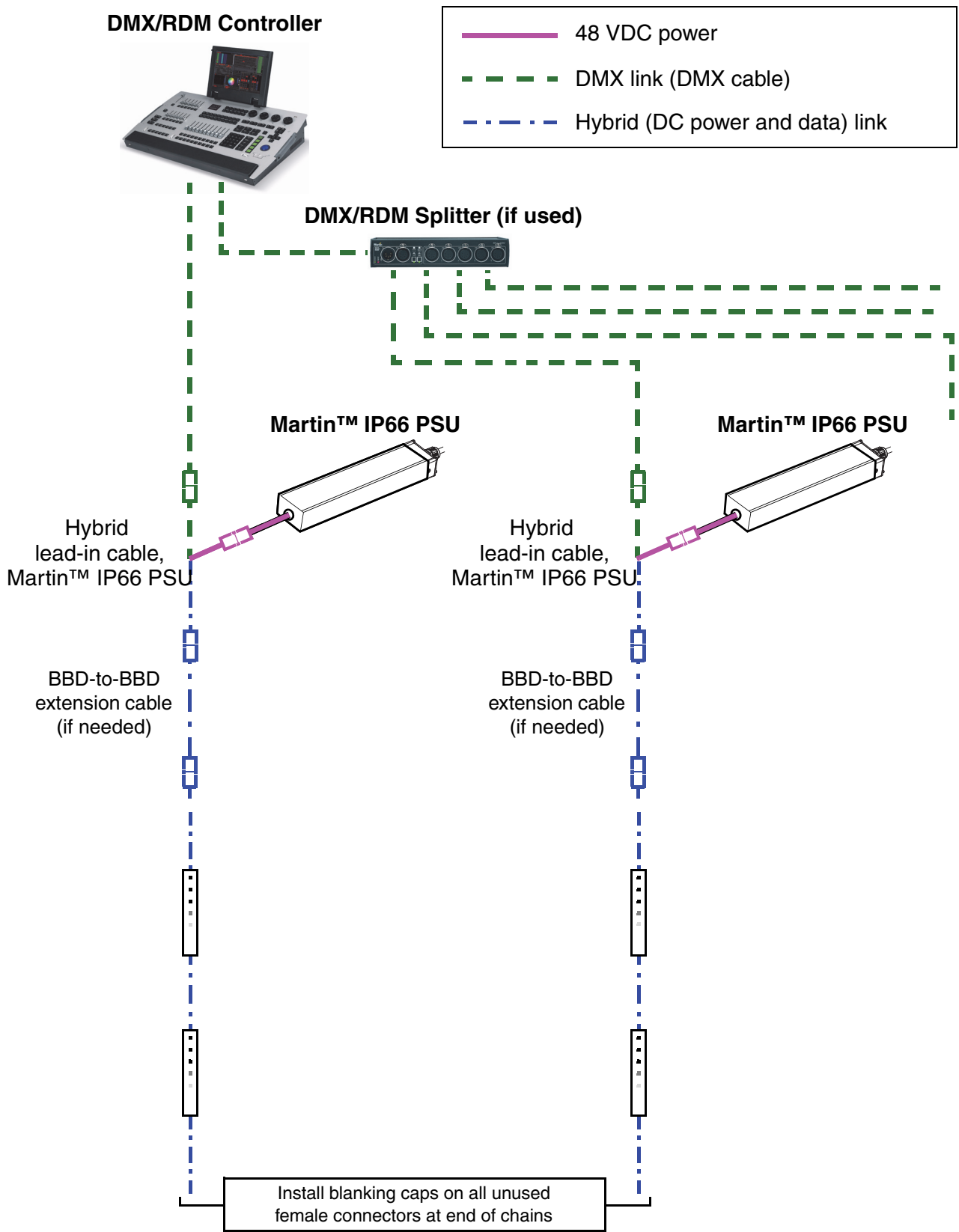

See “Safety limits for connecting devices” on page 6 before creating a chain

Figure 8: DMX-controlled system using the Martin™ IP66 Power Supply Unit

To create a DMX-controlled installation that draws DC power from the Martin™ IP66 PSU:

1. See Figure 8 on page 20 for an overview of this type of installation
2. Make sure that no devices in the installation can be connected to AC mains power until all installation work is complete.
3. Read “Safety information” on page 5 and “Precautions to avoid damage” on page 10.
4. Connect Exterior PixLine fixtures together in chains either directly using the fixtures’ cable tails and BBD connectors or by adding Martin™ hybrid cables with BBD connectors (see “Cables” on page 38).
Warning! Do not exceed the maximum total length of fixtures and total cable length per chain given in “Safety limits for connecting devices” on page 6.
5. Install a blanking cap (see “Cables” on page 38) on the output connector of the last fixture on each chain to protect from water, dirt etc. There is no need to install DMX termination plugs, as fixtures have integral DMX termination.
6. See Figure 9. Connect a Martin™ 5-pin XLR and Martin™ IP66 PSU to BBD adapter cable (P/N 91616050) to the start of each chain.
 - Connect the 5-pin male XLR connector on the adapter cable to a DMX link that carries a DMX signal from an RDM-compliant DMX controller such as the Martin M-PC™.
 - Connect the male Martin™ IP66 PSU connector on the adapter cable to the DC output of a Martin™ IP66 Power Supply Unit.
 - Connect the female BBD connector on the adapter cable to the male BBD connector at the start of the chain of Exterior PixLine fixtures.

XLR5+Martin™ IP66 PSU-to-BBD Input Cable, 0.25 m, P/N 91616050

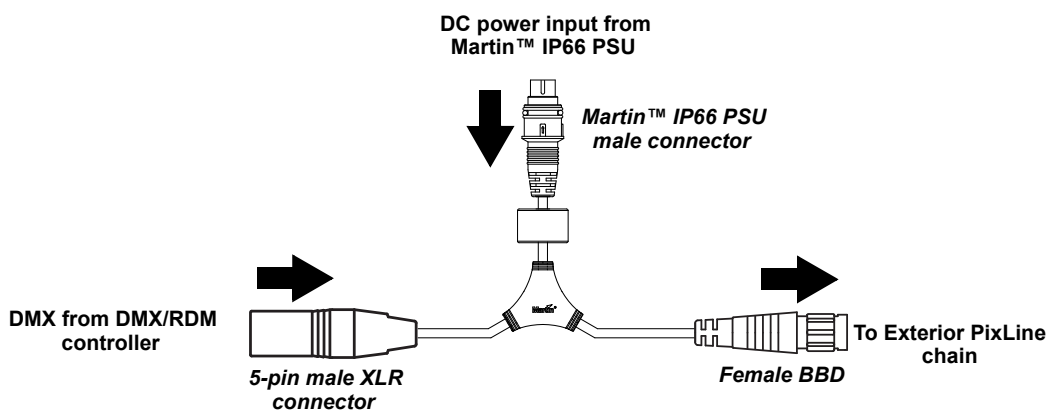
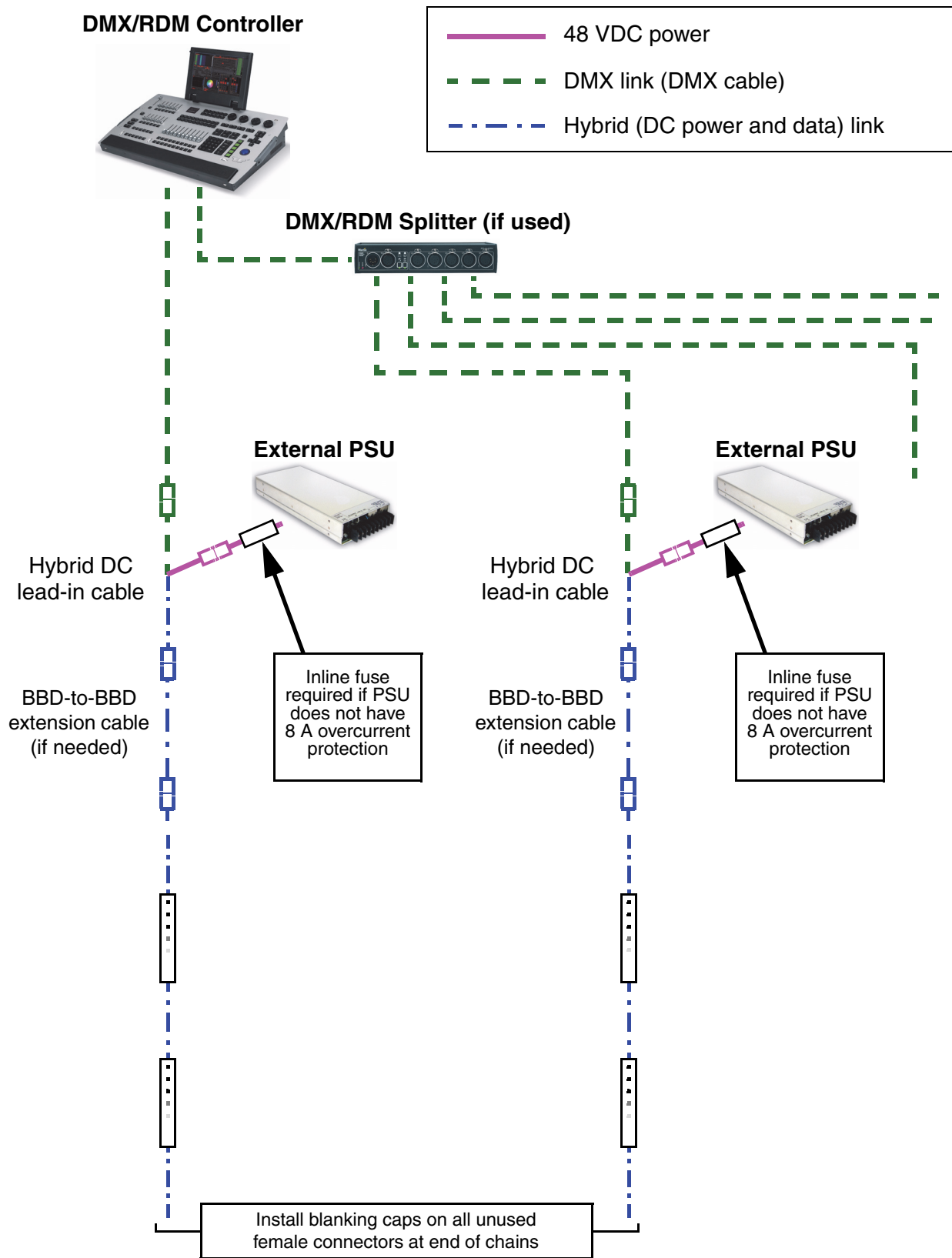

Figure 9: Martin™ IP66 PSU and DMX connections to an Exterior PixLine chain

7. Install a mains power cable on the Martin™ IP66 Power Supply Unit and connect it to AC mains power.
 8. Apply AC mains power to the DMX controller.
- You can now configure the system. See “System setup” on page 24.

Installing a DMX system using a generic external 48 VDC PSU



See "Safety limits for connecting devices" on page 6 before creating a chain. Do not exceed PSU output rating.

Figure 10: DMX-controlled system using a generic PSU

To create a DMX-controlled installation that draws DC power from a generic PSU:

1. See Figure 10 on page 22 for an overview of this type of installation.
2. Make sure that no devices in the installation can be connected to AC mains power until all installation work is complete.
3. Read "Safety information" starting on page 5 and "Precautions to avoid damage" on page 10.
4. Connect Exterior PixLine fixtures together in chains either directly using the fixtures' cable tails and BBD connectors or by adding Martin™ hybrid cables with BBD connectors (see "Cables" on page 38).

Warning! Do not exceed the maximum total length of fixtures and total length per chain given in "Safety limits for connecting devices" on page 6.

Warning! Check the PSU's DC output power rating in watts and the power consumption figures in watts for Exterior PixLine fixtures given in Table 4 on page 8. Do not create a chain of Exterior PixLine fixtures that will exceed the power rating of the DC output on the PSU. Even if the PSU's DC output power rating would be high enough, do not create a chain of Exterior PixLine fixtures that contains more than the maximum permitted number per chain given in Table 4 on page 8.

5. Install a blanking cap (see "Cables" on page 38) on the output connector of the last fixture on each chain to protect from water, dirt etc.
6. See Figure 11:
 - If the PSU does not have constant overcurrent protection that will limit current to 8 A on the DC output used, install an inline fuseholder with a 7.5 A or 8 A fuse on the white (+ve) power wire of a Martin™ Power and data adapter cable, XLR5 + power - BBD, 0.25 m (P/N 91616048). You can use a 30 amp automotive-type inline fuseholder with a 7.5 A blade fuse.
 - Connect the 5-pin male XLR connector on the power and data adapter cable to a DMX link that carries a DMX signal from an RDM-compliant DMX controller such as the Martin M1™ or M-PC™.
 - Connect the power wires on the power and data adapter cable to a DC output on the PSU. Connect the white wire to positive (+ve) and the black wire to negative (-ve).
 - Connect the female BBD connector on the adapter cable to the male BBD connector at the start of the chain of Exterior PixLine fixtures.

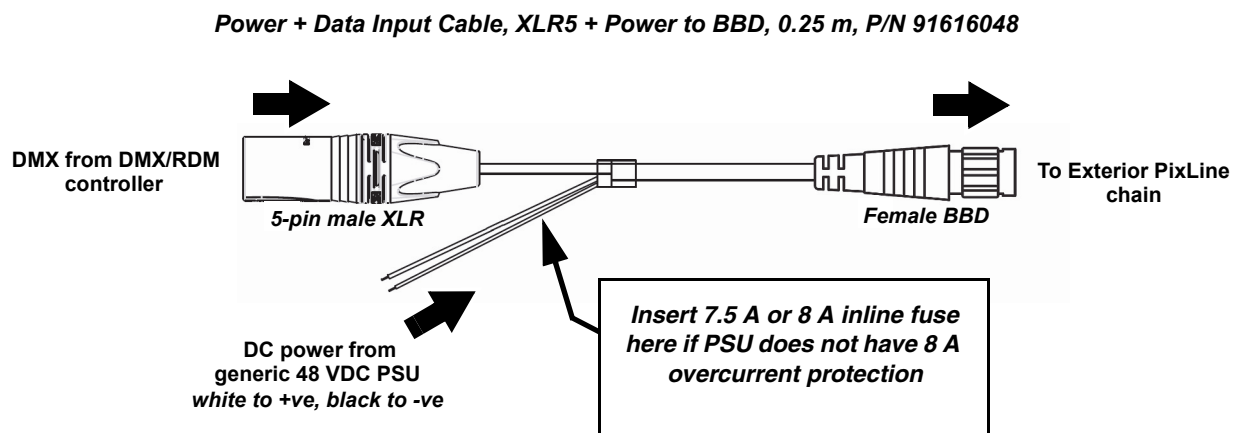

Figure 11: Generic PSU and DMX connections to an Exterior PixLine chain

7. Apply AC mains power to the external PSU.
8. Apply AC mains power to the DMX controller.

You can now configure the system. See "System setup" on page 24.

System setup



Warning! Read “Safety information” on page 5 and “Precautions to avoid damage” on page 10 before applying power to an Exterior PixLine installation.

Pixels and segments

A pixel is the smallest RGB-controllable unit in a fixture’s light output. A segment is a group of neighboring pixels that can be controlled as a unit.

Pixels and segments are numbered starting from the *female* connector end of fixtures: Pixel 1 and Segment 1 are closest to the female connector end.

Setting up for P3 display

A Martin P3™ system allows video to be displayed on an installation that consists of or includes Exterior PixLine fixtures. When a P3 controller is connected to the data link and the installation is powered on, you can set up all the devices on the link from the P3 controller. See the P3 controller user manual for details.

Setting up for DMX control

A DMX system gives 0 - 100% variable intensity control. Varying the intensity of red, blue and green LEDs in RGB products gives RGB color mixing.

You can set up and control an Exterior PixLine installation over the data link using an RDM-compatible DMX controller such as the Martin M-PC™ Windows application (running on a PC connected to a USB/DMX interface such as the Martin M-DMX Interface Box) the Martin M1™ DMX/RDM control console. The interface on the Martin M1™ monitor screen is basically identical to the Martin M-PC™ interface.

DMX control channels

DMX controllers send control data to devices over DMX control channels in DMX universes. One DMX universe has 512 channels available. Multiple fixtures can share the same DMX channels if you want grouped control and identical fixture behavior.

The Exterior PixLine can be controlled using four DMX modes (see under “DMX protocols” on page 32):

- In RGB mode, each fixture uses three DMX channels.
- In Basic mode, each fixture uses ten DMX channels.
- In Segment mode, each fixture uses seven DMX channels plus three DMX channels per segment:
 - 320 mm fixtures are divided into two segments
 - 1280 mm fixtures are divided into eight segments
 - Custom length fixtures are divided into segments of 160 mm. If the fixture length is not a multiple of 160 mm, the last segment will be shorter than 160 mm.
- In Pixel mode, each fixture uses seven DMX channels plus three DMX channels per pixel.

Type of Exterior PixLine fixture	DMX channels per fixture, RGB mode	DMX channels per fixture, Basic mode	DMX channels per fixture, Segment mode	DMX channels per fixture, Pixel mode
Exterior PixLine 10, 320 mm	3	10	13	103
Exterior PixLine 10, 1280 mm	3	10	31	391
Exterior PixLine 20, 320 mm	3	10	13	55
Exterior PixLine 20, 1280 mm	3	10	31	199
Exterior PixLine 40, 320 mm	3	10	13	31

Table 5: Number of DMX channels required per Exterior PixLine fixture

Type of Exterior PixLine fixture	DMX channels per fixture, RGB mode	DMX channels per fixture, Basic mode	DMX channels per fixture, Segment mode	DMX channels per fixture, Pixel mode
Exterior PixLine 40, 1280 mm	3	10	31	103
All fixtures, custom lengths	3	10	7 plus 3 per 160 mm segment	7 plus 3 per pixel

Table 5: Number of DMX channels required per Exterior PixLine fixture

Different modes can be mixed freely in an installation. For example, some Exterior PixLine fixtures can be set to RGB mode, some set to Basic mode and others to Pixel mode. All you need to do is set up fixtures, DMX addresses and DMX channel allocation correctly.

DMX addresses

To prepare an installation for DMX control, you set it up using an RDM-compliant DMX controller so that fixtures or pixels receive instructions from the controller on their own DMX channels. The DMX address (also known as the control address or start channel) is the first of these channels. An Exterior PixLine fixture or pixel uses more than one channel, so it uses the DMX address channel and the channels immediately above it. For example, one Exterior PixLine fixture set to RGB mode and set to DMX address 1 will use DMX channels 1 - 3. Channel 4 will be available for use as a DMX address for the next device.

RDM

Using an RDM-compliant DMX controller such as Martin M-PC™, you can communicate with the Exterior PixLine fixtures on the DMX data link via RDM. You can:

- Retrieve data from fixtures
- Set the DMX addresses of the fixtures and set their DMX mode
- Reset fixtures

To use Martin M-PC, connect a PC running this application to the data link using the Martin M-DMX USB/DMX interface box.

The Exterior PixLine responds to the RDM parameter IDs listed in Table 6.

RDM parameter IDs	GET allowed	SET allowed
Category – Network Management		
DISC_UNIQUE_BRANCH		
DISC_MUTE		
DISC_UN_MUTE		
Category - Product Information		
DEVICE_INFO	✓	
DEVICE_MODEL_DESCRIPTION	✓	
MANUFACTURER_LABEL	✓	
DEVICE_LABEL	✓	✓
SOFTWARE_VERSION_LABEL	✓	
Category - DMX512 Setup		
DMX_PERSONALITY	✓	✓
DMX_PERSONALITY_DESCRIPTION	✓	
DMX_START_ADDRESS	✓	✓
SLOT_DESCRIPTION	✓	
Category - Control		
IDENTIFY_DEVICE	✓	✓
RESET_DEVICE		✓

Table 6: RDM communication with the Exterior PixLine

Using the Exterior PixLine



Warning! Read “Safety information” on page 5 and “Precautions to avoid damage” on page 10 on before applying power to the Exterior PixLine.

Do not use the Exterior PixLine if the ambient temperature exceeds 55° C (131° F) or falls below -20° C (-4° F).

P3 display

The Exterior PixLine can display video from all common video sources. The video signal must be sent to a Martin P3™ controller and then distributed to fixtures. The P3™ controller lets you map, configure and control an installation containing Exterior PixLine fixtures (and other Martin P3™ video display products if you have them). See the P3 controller documentation for details.

DMX control

The Exterior PixLine can display effects controlled by DMX. Three DMX modes are available:

- **RGB mode** uses three DMX channels and gives RGB color mixing of all the pixels on a fixture.
- **Basic mode** uses ten DMX channels and gives RGB color mixing, strobe effects and pre-programmed dynamic effects.
- **Segment mode** uses the first seven DMX channels of Basic mode plus three channels per segment for segment-level RGB color mixing, strobe effects and pre-programmed FX. 320 mm fixtures are divided into two segments, 1280 mm fixtures are divided into eight segments.
- **Pixel mode** uses the same ten DMX channels as Basic mode plus three channels per pixel for pixel-level RGB color mixing, strobe effects and pre-programmed dynamic effects.

See “DMX protocols” on page 32 for full details of DMX control.

An RDM-compatible controller is required so that you can address and configure the fixtures. See the DMX/RDM controller documentation for details.

Magnetic ‘control button’

A magnetic sensor is embedded inside the Exterior PixLine behind the label on the back of the fixture (see C in Figure 1 on page 11). The sensor acts as a control button. To activate the sensor, swipe a magnet past the side of the fixture near where the input cable tail enters the fixture.

You may find it convenient to use the Martin Test Tool (see “Accessories” on page 38), which contains a magnet.

Activating the magnetic sensor lets you display the product’s status, test the LEDs and reset the Exterior PixLine as explained in the following table.



Figure 12: Test Tool with magnet

Status display

To display a Exterior PixLine fixture's status, swipe the magnet over the sensor once. The first four and last two LEDs on the fixture will give one of the indications listed in the tables below for a few seconds.

Color	Output	Indication	Action required
Blue	Constant	Busy (e.g. booting up or writing to flash memory).	Wait a moment for normal operation to be resumed.
Red	Constant	Error. The Exterior PixLine has encountered a fatal error and can not run.	Perform a factory reboot, followed by a firmware upload.
Red	Flashing	No control source detected.	Connect a P3 system controller or DMX controller to the network.
Green	Flashing	Ready. Exterior PixLine connected to P3 controller but not mapped onto the canvas.	Set up the P3 controller to use the Exterior PixLine.
Green	Constant	Running normally in P3 mode.	None.
Cyan	Flashing	Ready. Exterior PixLine connected to DMX controller but not receiving valid DMX data.	Send DMX data (if flashing cyan continues although you are sending data, check that DMX controller is connected correctly and configured with Exterior PixLine's DMX address).
Cyan	Constant	Running normally in DMX mode.	None.

Table 7: Status information

Testing, rebooting and returning to defaults

The tables below list the functions of the magnetic 'control button' on each Exterior PixLine fixture.

Test patterns are stored in onboard memory. This lets you test the LEDs without an external controller, but test patterns can also be called up on P3 system controllers, the P3 PowerPort 1500™ and the P3 PowerPort 1000 IP™.

Action	Function
Quick swipe	The first swipe displays status as shown in Table 7 for a few seconds. The next swipes display the following test patterns on the LEDs (each swipe scrolls to the next pattern): <ul style="list-style-type: none"> - Calibrated white - Full red - Full green - Full blue - Scrolling gradient - Dimmed (20% uncalibrated white)
Hold magnet over 'button' until LEDs 1-4 light blue	Reboot the Exterior PixLine.
Hold magnet over 'button' until LEDs 1-4 light white	Return the Exterior PixLine to its default factory firmware.

Table 8: Magnetic 'control button' functions

Service and maintenance



Warning! Read “Safety information” on page 5 and “Precautions to avoid damage” on page 10 before carrying out service on the Exterior PixLine.

Warning! Lock out AC mains power to the installation before servicing.

Warning! Refer any service operation not described in this manual to a qualified service technician.

Important! Excessive dirt buildup causes overheating and may damage the product. Damage caused by inadequate cleaning is not covered by the product warranty.

The user will need to clean the Exterior PixLine periodically. All other service operations on the Exterior PixLine must be carried out by Martin Professional™ or its approved service agents.

Installation, on-site service and maintenance can be provided worldwide by the Martin Professional Global Service organization and its approved agents, giving owners access to Martin's expertise and product knowledge in a partnership that will ensure the highest level of performance throughout the product's lifetime. Please contact your Martin supplier for details.

Cleaning

Cleaning schedules vary depending on the operating environment. It is therefore impossible to specify precise cleaning intervals for the Exterior PixLine. Environmental factors that may result in a need for frequent cleaning include airborne dust and pollution.

Inspect products frequently to see whether cleaning is necessary. If in doubt, consult your Martin™ dealer about a suitable maintenance schedule.

To clean the product, use warm water and a soft brush or a low-pressure or medium-pressure water jet. Use car shampoo to help remove dirt and grease. If possible, dry with a soft cloth to avoid streaking. Do not use a stiff brush or scouring pad. Do not use solvents or abrasives.

Condensation and pressure relief valve

Under certain conditions, condensation may become visible inside fixtures. This is normal and harmless. Any condensation will gradually be expelled by the fixture's Gore-Tex pressure relief valve (see Figure 2 on page 13) as the fixture goes through power off/on cycles.

Make sure that the pressure relief valve is clean and unblocked. The valve must be able to breathe freely so that it can equalize pressure and expel water vapor. If a valve becomes blocked, excessive pressure can damage seals or cause air and water to be sucked along cables and into the fixture.

Water on the valve membrane will block the membrane's micropores. Do not allow water to collect on or near valves. If you suspect that a valve has become blocked with dirt, contact your Martin supplier.

LED performance

Martin™ use the best components available, but the characteristics of all LEDs change gradually over many thousands of hours of use. Not all colors change at the same rate, and rates of change vary depending on factors such as temperature and how intensively a particular color is used. Because of the changes, overall light output and the exact hues obtained from specific color mixes in all LED-based products can be expected to shift slightly over time.

To help you obtain consistent output despite these changes, Martin™ P3 software from version 4.1.0 contains the P3 Fixture Adjuster tool. This feature lets you compensate for changes in LED characteristics and restore initial output and color authenticity levels. Please contact Martin™ for more details.

Installing new software

It may be necessary to upload new software (i.e. device firmware) to the Exterior PixLine if it appears to have a software-related fault or if you want to update to a newer software version.

Software for Martin™ products is available from the Martin™ website. The Exterior PixLine software can be installed from the P3 System Controller over the P3 data link. You will need a Martin P3 PowerPort 1500™ or a Martin P3 PowerPort 1000 IP™ for this. See the P3 System Controller user manual for software installation instructions.

Troubleshooting

Problem	Probable cause(s)	Remedy
Control is lost and activating magnetic 'control button' causes Exterior PixLine to show constant or flashing red status indication.	Error has occurred.	Check that system is correctly connected, set up and running. Hold magnet over 'control button' until LEDs 1 - 4 turn blue, then move magnet away, to reboot Exterior PixLine. Restart P3 or DMX controller.
Product seems completely dead.	Product has gone into thermal protection shutdown.	Check product temperature readouts on P3 system controller. Reduce ambient temperature by providing ventilation or fan cooling, for example.
	No DC power to product.	Check 48 VDC power supply and cables
	Internal fault.	Disconnect from power. Do not attempt repairs yourself. Contact Martin™ Service or an authorized Martin™ service partner for assistance.
Exterior PixLine does not display as intended.	Fault in 48 VDC power transmission.	Inspect connections and cables. Correct poor connections. Repair or replace damaged cables.
	Fault in data transmission.	Inspect connections and cables. Correct poor connections. Repair or replace damaged cables.
	Incorrect mapping or addressing of products.	Check product address and controller settings.
	Product in installation is defective and is disturbing data transmission.	Substitute known good products one at a time until normal operation is regained. Have faulty product serviced by Martin™ Service.

Table 9: Troubleshooting

DMX protocols

RGB Mode

Channel	DMX Value	Function
1	0 - 255	Red 0 → 100%
2	0 - 255	Green 0 → 100%
3	0 - 255	Blue 0 → 100%

Table 10: DMX Protocol, RGB Mode

Basic Mode

Channel	DMX Value	Function
1	0 - 65535	Dimmer fade (MSB) 8-bit coarse control, closed 0% → open 100%
2		Dimmer fade (LSB) 16-bit fine adjustment, closed → open
3	0 - 49 50 - 200 201 - 210 211 - 255	Strobe No strobe Strobe, slow → fast No strobe Random strobe, slow → fast
4	0 - 255	Strobe duration 0 → 1 second
5	0 - 7 8 - 255	FX selection No FX: output controlled on RGB channels FX selection (see “Pre-programmed FX” on page 35)
6	0 - 126 127 - 128 129 - 255	FX speed / modifier (depending on effect) Fast → slow Stop Slow → fast
7	0 1 2 3 - 34 35 36 37 - 100 101 - 120 121 - 140 141 - 255	FX synchronization No sync Fixture offset 10° Fixture offset 10° ... Fixture offset 350° Synchronized <i>No function (reserved for future use)</i> Random start Random duration <i>No function (reserved for future use)</i>
8	0 - 255	Red 0 → 100%
9	0 - 255	Green 0 → 100%
10	0 - 255	Blue 0 → 100%

Table 11: DMX Protocol, Basic Mode

Segment Mode

Channel	DMX Value	Function
1	0 - 65535	Dimmer fade (MSB) 8-bit coarse control, closed 0% → open 100%
		Dimmer fade (LSB) 16-bit fine adjustment, closed → open
3	0 - 49	Strobe No strobe
	50 - 200	Strobe, slow → fast
	201 - 210	No strobe
	211 - 255	Random strobe, slow → fast
4	0 - 255	Strobe duration 0 → 1 second
5	0	FX selection No FX: output controlled on RGB channels
	1 - 255	FX selection (see "Pre-programmed FX" on page 35)
6	0 - 126	FX speed / modifier (depending on effect) Fast → slow
	127 - 128	Stop
	129 - 255	Slow → fast
7	0	FX synchronization No sync
	1	Fixture offset 10°
	2	Fixture offset 10°
	3 - 34	...
	35	Fixture offset 350°
	36	Synchronized
	37 - 100	<i>No function (reserved for future use)</i>
	101 - 120	Random start
	121 - 140	Random duration
	141 - 255	<i>No function (reserved for future use)</i>
Segment control		
8	0 - 255	Segment 1 Red 0 → 100%
9	0 - 255	Segment 1 Green 0 → 100%
10	0 - 255	Segment 1 Blue 0 → 100%
11	0 - 255	Segment 2 Red 0 → 100%
12	0 - 255	Segment 2 Green 0 → 100%
13	0 - 255	Segment 2 Blue 0 → 100%
Etc...
	Channels used for RGB control of segments:	
	<ul style="list-style-type: none"> • 320 mm fixtures (two 160 mm segments) = channels 8 - 13 • 1280 mm fixtures (eight 160 mm segments) = channels 8 - 31 	

Table 12: DMX Protocol, Segment Mode

Pixel Mode

Channel	DMX Value	Function
1	0 - 65535	Dimmer fade (MSB) 8-bit coarse control, closed 0% → open 100%
		Dimmer fade (LSB) 16-bit fine adjustment, closed → open
3	0 - 49	Strobe No strobe
	50 - 200	Strobe, slow → fast
	201 - 210	No strobe
	211 - 255	Random strobe, slow → fast
4	0 - 255	Strobe duration 0 → 1 second
5	0 - 7	FX selection No FX: output controlled on RGB channels
	8 - 255	FX selection (see "Pre-programmed FX" on page 35)
6	0 - 126	FX speed / modifier (depending on effect) Fast → slow
	127 - 128	Stop
	129 - 255	Slow → fast
7	0	FX synchronization No sync
	1	Fixture offset 10°
	2	Fixture offset 10°
	3 - 34	...
	35	Fixture offset 350°
	36	Synchronized
	37 - 100	<i>No function (reserved for future use)</i>
	101 - 120	Random start
	121 - 140	Random duration
141 - 255	<i>No function (reserved for future use)</i>	
Individual pixel control		
8	0 - 255	Pixel 1 Red 0 → 100%
9	0 - 255	Pixel 1 Green 0 → 100%
10	0 - 255	Pixel 1 Blue 0 → 100%
11	0 - 255	Pixel 2 Red 0 → 100%
12	0 - 255	Pixel 2 Green 0 → 100%
13	0 - 255	Pixel 2 Blue 0 → 100%
14	0 - 255	Pixel 3 Red 0 → 100%
Etc...	Etc... Channels used for individual RGB control of individual pixels: <ul style="list-style-type: none"> • Sceptron 10, 320 mm = channels 8 - 103 • Sceptron 10, 1280 mm = channels 8 - 391 • Sceptron 20, 320 mm = channels 8 - 55 • Sceptron 20, 1280 mm = channels 8 - 199 • Sceptron 40, 320 mm = channels 8 - 31 • Sceptron 40, 1280 mm = channels 8 - 103 	

Table 13: DMX Protocol, Pixel Mode

Pre-programmed FX

Select the FX in this table on channel 5 in Basic Mode or Pixel Mode.

Set FX execution speed on channel 6.

Synchronize and set offsets between fixtures on channel 7.

Channel	DMX Value	Function
5	0	No FX
		Intensity FX
	1	Wave
	2	Step
	3	Pulse
	4	Blackout strobe
	5	2x strobe
	6	3x strobe
	7	4x strobe
	8	Up, down flash
	9	Up, flash, down, flash
	10	Random levels
	11	Pixel killer
	12	Noise overlay
	13 - 19	<i>No function (reserved for future use)</i>
	20	Movie flicker
	21	Electric arc
	22	Atomic lightning
	23	Thunderstorm
	24 - 50	<i>No function (reserved for future use)</i>
		Color FX
	51	Rainbow wave
	52	Rainbow step
	53	Rainbow pulse
	54	RGB wave
	55	RGB step
	56	RGB pulse
	57	CMY wave
	58	CMY step
	59	CMY pulse
	60	Random mix wave
	61	Random mix step
	62	Random mix pulse
	63 - 68	<i>No function (reserved for future use)</i>
	69	Solid
	70	Spectrum shifter
	71	RGB to white wave
	72	RGB to white step
	73	RGB to white pulse
	74	RGB to white strobe
	75	Normal to white wave
	76	Normal to white step
	77	Normal to white pulse
	78	Normal to white strobe
	79	Video to RGB wave
	80	Video to RGB step
	81	Video to RGB pulse
	82	Video to RGB strobe
	83	Video to video + RGB wave
	84	Video to video + RGB step
	85	Video to video + RGB pulse
	86	Video to video + RGB strobe
	87-100	<i>No function (reserved for future use)</i>

Table 14: Pre-programmed FX

Specifications

Physical

Length, standard fixtures	310/320 mm (12.2/12.6 in.) and 1270/1280 mm (50.0/50.4 in.)
Length, custom fixtures	300 mm - 2000 mm (11.9 - 78.8 in.), available by special order
Width27 mm (1.07 in.)
Height with flat diffuser / clear front32 mm (1.26 in.)
Height with flat diffuser / clear front in mounting profile74 mm (2.92 in.)
Height with graze (asymmetric wallwasher) lens42 mm (1.65 in.)
Height with graze (asymmetric wallwasher) lens in mounting profile84 mm (3.31 in.)
Height with round diffuser42 mm (1.65 in.)
Height with round diffuser in mounting profile84 mm (3.31 in.)
Weight including diffuser	1.3 kg per meter (0.9 lbs. per foot)
Weight including mounting profile and diffuser	2.0 kg per meter (1.4 lbs. per foot)

Control and Programming

Control optionsMartin P3™ System Controller (via Martin P3 PowerPort 1500™ or P3 PowerPort 1000 IP™) and/or DMX
Protocol detection	Automatic
Control modes	RGB, basic, segment-level and pixel-level
Setting and addressing	P3 System controller or RDM-compliant controller
Control resolution	16-bit (P3) or 8-bit (DMX) control of each color
Color and intensity calibration	Pixel-level
DMX compliance	USITT DMX512-A
RDM compliance	ANSI/ESTA E1.20
Firmware update	Via P3 System controller

DMX channels

Exterior Pixline™ 10	3/10/13/31/103/391
Exterior Pixline™ 20	3/10/13/31/55/199
Exterior Pixline™ 40	3/10/13/31/31/103

Signal Protocol

P3 (via Martin P3 PowerPort™) or DMX

Control/User Interface

Device status	Multi-color visual indication
Device test and reset	Magnetic pushbutton to call up local test patterns and reset device

Video Processing

- Brightness control
- Gamma correction and control
- Color temperature control
- Color space control
- Calibration processing
- Synchronization

Optics

Available options

- Clear front window
- Flat Diffuser
- Round Diffuser
- Square Diffuser
- Asymmetric* wallwasher lens

*Asymmetric lenses are defined as follows:

Left = looking from male towards female connector, light output towards wall is on left.

Right = looking from male towards female connector, light output towards wall is on right.

All fixtures

Minimum LED lifetime	50 000 hours (to >70% luminous output)*
Color resolution	16 bits per color (48 bits per pixel)
Viewing angle	120° x 120°

*Figure obtained under manufacturer's test conditions

Exterior PixLine™ 10

Pixels per meter	100
Pitch (pixel center-to-center)	10.00 mm

Exterior PixLine™ 20

Pixels per meter	50
Pitch (pixel center-to-center)	20.00 mm

Exterior PixLine™ 40

Pixels per meter	25
Pitch (pixel center-to-center)	40.00 mm

For full photometric data, see the Martin website at www.martin.com

Construction

Base	Extruded aluminum profile
Color	Clear anodized (custom RAL colors available by special order)
Protection rating	IP66
Impact resistance	IK05
RoHS compliant	

Installation

Orientation	Any
Mounting options	M6 bolts, pre-install mounting profile system

Connections

Power and data input	6-pin custom BBD-type IP66-rated
Power and data thru	6-pin custom BBD type IP66-rated

Electrical

Nominal input voltage	48 VDC +/- 4%
Power supply options	Martin P3™ PowerPort 1500, Martin P3™ PowerPort 1000 IP, Martin™ IP66 Power Supply Unit or generic 48 VDC PSU

Power Consumption

Exterior PixLine™ 10

Typical total power consumption	.33 W per meter at full intensity, full white
---------------------------------	---

Exterior PixLine™ 20

Typical total power consumption	.17 W per meter at full intensity, full white
---------------------------------	---

Exterior PixLine™ 40

Typical total power consumption	8.5 W per meter at full intensity, full white
---------------------------------	---

Allow for +/-10% variation in power consumption figures

Thermal

Cooling	Convection
Maximum ambient temperature (Ta max.) for typical video content	55° C (131° F)
Minimum ambient temperature (Ta min.)	-20° C (-4° F)

Exterior PixLine™ 10

Max. total heat dissipation, calculated, +/- 10%	115 BTU/hr per meter
--	----------------------

Exterior PixLine™ 20

Max. total heat dissipation, calculated, +/- 10%	60 BTU/hr per meter
--	---------------------

Exterior PixLine™ 40

Max. total heat dissipation, calculated, +/- 10%	30 BTU/hr per meter
--	---------------------

Approvals



EU safety	EN 60950-1, EN 60950-22, EN 62471
EU EMC	EN 55024, EN 55032
US safety	UL 60950-1, UL 60950-22
US EMC	CFR Title 47 Part 15 Class A
Canadian safety	CSA C22.2 No. 60950-1, No. 60950-22
Canadian EMC	ICES-003 Class A
Australia/NZ (pending)	RCM

Accessories

Magnetic Test Tool, set of 10 P/N 91610139

Mounting profiles

Exterior PixLine Mounting Profile, 320 mm, Aluminum, for PixLine 10 P/N 91611620
Exterior PixLine Mounting Profile, 1280 mm, Aluminum, for PixLine 10 P/N 91611610
Exterior PixLine Mounting Profile, 310 mm, Aluminum, for PixLine 20/40 P/N 91611700
Exterior PixLine Mounting Profile, 1270 mm, Aluminum, for PixLine 20/40 P/N 91611710
Exterior PixLine Mounting Profile Locks, set of 10 P/N 91611725

Cables

Power + Data Input Cable, 4-pin male XLR (for P3 PowerPort)
to female BBD, 0.25 m (9.8 in.) P/N 91616046
Power + Data Input Cable, 5-pin male XLR (for DMX) + wire tails (for PSU)
to female BBD, 0.25 m (9.8 in.) P/N 91616048
Power + Data Input Cable, 5-pin male XLR (for DMX) + 4-pin male XLR (for
P3 PowerPort) to female BBD, 0.25 m (9.8 in.) P/N 91616049
Power + Data Input Cable, 5-pin male XLR (for DMX) + male Tripix type (for
Martin™ IP66 PSU 240W) to female BBD, 0.25 m (9.8 in.) P/N 91616050
Power + Data Extension Cable, Installation Type, CMX, BBD to BBD 1 m (3.3 ft.) P/N 91616055
Power + Data Extension Cable, Installation Type, CMX, BBD to BBD, 2.5 m (8.2 ft.) P/N 91616056
Power + Data Extension Cable, Installation Type, CMX, BBD to BBD, 5 m (16.4 ft.) P/N 91616057
Power + Data Extension Cable, Installation Type, CMX, BBD to BBD, 10 m (32.8 ft.) P/N 91616058
Power + Data Extension Cable, Installation Type, CMX, BBD to BBD, 25 m (82.1 ft.) P/N 91616059
Power + Data Extension Cable, Installation Type, CMX,
100 m (328 ft.) bulk without connectors P/N 91616060
Power + Data Output Cable, male BBD
to 4-pin female XLR, 0.25m (9.8 in.) P/N 91616047
DMX Lead-out Cable, male BBD to 5-pin female XLR, 0.25 m (9.8 in.) P/N 91616051

Connectors

Power + Data Cable Connector, BBD, Male P/N 91611750
Power + Data Cable Connector, BBD, Female P/N 91611751
Blanking Caps for sealing unused female BBD connectors, set of 10 P/N 91616052

Related Items

Martin P3™ PowerPort 1500 P/N 90721040
Martin P3™ PowerPort 1000 IP, Installation model P/N 90721080
Martin™ IP66 PSU 240W external power supply unit (was Tripix Power IP66) P/N 90760330
Martin P3-050™ System Controller P/N 90721090
Martin P3-100™ System Controller P/N 90721010
Martin P3-150™ System Controller P/N 90721015
Martin P3-200™ System Controller P/N 90721020
Martin P3-300™ System Controller P/N 90721060
Martin P3-PC™ System Controller P/N 90721030

Ordering Information

Exterior Pixline™ 10

Exterior PixLine 10 RGB, 320 mm, Aluminum, Clear Front	P/N 90356895
Exterior PixLine 10 RGB, 1280 mm, Aluminum, Clear Front	P/N 90356890
Exterior PixLine 10 RGB, 320 mm, Aluminum, Flat Diffuser Front	P/N 90356885
Exterior PixLine 10 RGB, 1280 mm, Aluminum, Flat Diffuser Front	P/N 90356880
Exterior PixLine 10 RGB, 320 mm, Aluminum, Round Diffuser Front	P/N 90356875
Exterior PixLine 10 RGB, 1280 mm, Aluminum, Round Diffuser Front	P/N 90356870
Exterior PixLine 10 RGB, 320 mm, Aluminum, Square Diffuser Front.	P/N 90356865
Exterior PixLine 10 RGB, 1280 mm, Aluminum, Square Diffuser Front.	P/N 90356860
Exterior PixLine 10 RGB, 320 mm, Alu., Graze (Asymmetric Wallwasher) Lens, Left*	P/N 90356855
Exterior PixLine 10 RGB, 1280 mm, Alu., Graze (Asymmetric Wallwasher) Lens, Left*	P/N 90356850
Exterior PixLine 10 RGB, 320 mm, Alu., Graze (Asymmetric Wallwasher) Lens, Right*	P/N 90356845
Exterior PixLine 10 RGB, 1280 mm, Alu., Graze (Asymmetric Wallwasher) Lens, Right*	P/N 90356840

Exterior Pixline™ 20

Exterior PixLine 20 RGB, 310 mm, Aluminum, Clear Front	P/N 90356835
Exterior PixLine 20 RGB, 1270 mm, Aluminum, Clear Front	P/N 90356830
Exterior PixLine 20 RGB, 310 mm, Aluminum, Flat Diffuser Front	P/N 90356825
Exterior PixLine 20 RGB, 1270 mm, Aluminum, Flat Diffuser Front	P/N 90356820
Exterior PixLine 20 RGB, 310 mm, Aluminum, Round Diffuser Front	P/N 90356815
Exterior PixLine 20 RGB, 1270 mm, Aluminum, Round Diffuser Front	P/N 90356810
Exterior PixLine 20 RGB, 310 mm, Aluminum, Square Diffuser Front.	P/N 90356805
Exterior PixLine 20 RGB, 1270 mm, Aluminum, Square Diffuser Front.	P/N 90356800
Exterior PixLine 20 RGB, 310 mm, Alu., Graze (Asymmetric Wallwasher) Lens, Left*	P/N 90356795
Exterior PixLine 20 RGB, 1270 mm, Alu., Graze (Asymmetric Wallwasher) Lens, Left*	P/N 90356790
Exterior PixLine 20 RGB, 310 mm, Alu., Graze (Asymmetric Wallwasher) Lens, Right*	P/N 90356785
Exterior PixLine 20 RGB, 1270 mm, Alu., Graze (Asymmetric Wallwasher) Lens, Right*	P/N 90356780

Exterior Pixline™ 40

Exterior PixLine 40 RGB, 310 mm, Aluminum, Clear Front	P/N 90356775
Exterior PixLine 40 RGB, 1270 mm, Aluminum, Clear Front	P/N 90356770
Exterior PixLine 40 RGB, 310 mm, Aluminum, Flat Diffuser Front	P/N 90356765
Exterior PixLine 40 RGB, 1270 mm, Aluminum, Flat Diffuser Front	P/N 90356760
Exterior PixLine 40 RGB, 310 mm, Aluminum, Round Diffuser Front	P/N 90356755
Exterior PixLine 40 RGB, 1270 mm, Aluminum, Round Diffuser Front	P/N 90356750
Exterior PixLine 40 RGB, 310 mm, Aluminum, Square Diffuser Front.	P/N 90356745
Exterior PixLine 40 RGB, 1270 mm, Aluminum, Square Diffuser Front.	P/N 90356740
Exterior PixLine 40 RGB, 310 mm, Alu., Graze (Asymmetric Wallwasher) Lens, Left*	P/N 90356735
Exterior PixLine 40 RGB, 1270 mm, Alu., Graze (Asymmetric Wallwasher) Lens, Left*	P/N 90356730
Exterior PixLine 40 RGB, 310 mm, Alu., Graze (Asymmetric Wallwasher) Lens, Right*	P/N 90356725
Exterior PixLine 40 RGB, 1270 mm, Alu., Graze (Asymmetric Wallwasher) Lens, Right*	P/N 90356720

**For Graze models with asymmetric lenses, Left or Right indicates the direction of the light output from the fixture when looking from the male connector (power and data input) end towards the female connector end of the fixture*

Specifications subject to change without notice. For the latest product specifications, see www.martin.com

FCC Compliance

This device complies with Part 15 of the FCC Rules. Operation is subject to the following two conditions: (1) This device may not cause harmful interference, and (2) this device must accept any interference received, including interference that may cause undesired operation.

Canadian Interference-Causing Equipment Regulations - *Règlement sur le Matériel Brouilleur du Canada*

This Class A digital apparatus meets all requirements of the Canadian Interference-Causing Equipment Regulations.
Cet appareil numérique de la classe A respecte toutes les exigences du Règlement sur le Matériel Brouilleur du Canada.

EU EMC

Operation of this equipment in a residential environment could cause radio interference.

Not for use in a computer room as defined in the Standard for the Protection of Information Technology Equipment, ANSI/NFPA 75.

Ne peut être utilisé dans une salle d'ordinateurs telle que définie dans la norme ANSI/NFPA 75 'Standard for the Protection of Information Technology Equipment'.

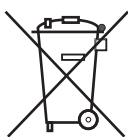

Disposing of this product

Martin™ products are supplied in compliance with Directive 2002/96/EC of the European Parliament and of the Council of the European Union on WEEE (Waste Electrical and Electronic Equipment), as amended by Directive 2003/108/EC, where applicable.

Help preserve the environment! Ensure that this product is recycled at the end of its life. Your supplier can give details of local arrangements for the disposal of Martin products.



www.martin.com • Olof Palmes Allé 18 • 8200 Aarhus N • Denmark
Tel: +45 8740 0000 • Fax +45 8740 0010