

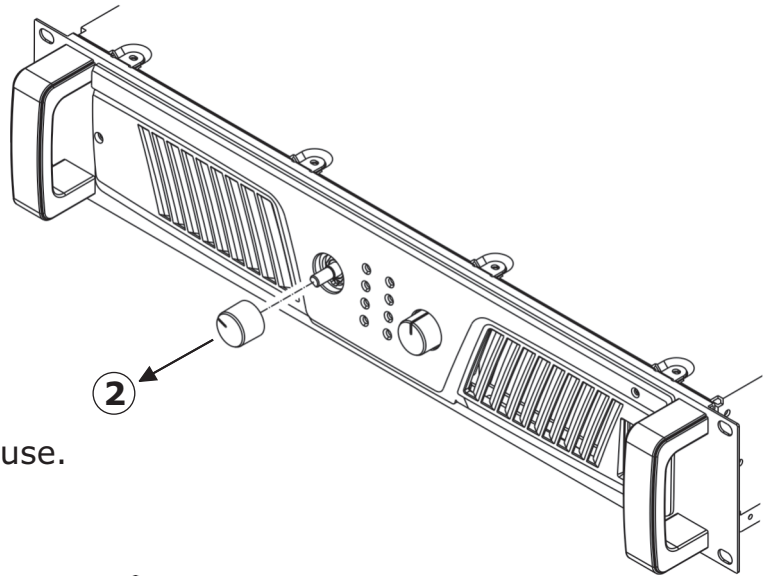

Security Knob Installation for KLR Amplifier Level Controls

- ① Set knob at desired level.
- ② Carefully remove original knob by pulling it straight off without turning shaft.
- ③ Save original knob for future use.



- ④ Install the lock-washer provided with the knob kit.
- ⑤ Carefully install the security knob by screwing it onto the potentiometer shaft threads. The security knob will turn but the potentiometer shaft will not. *Turn by hand until finger tight.*

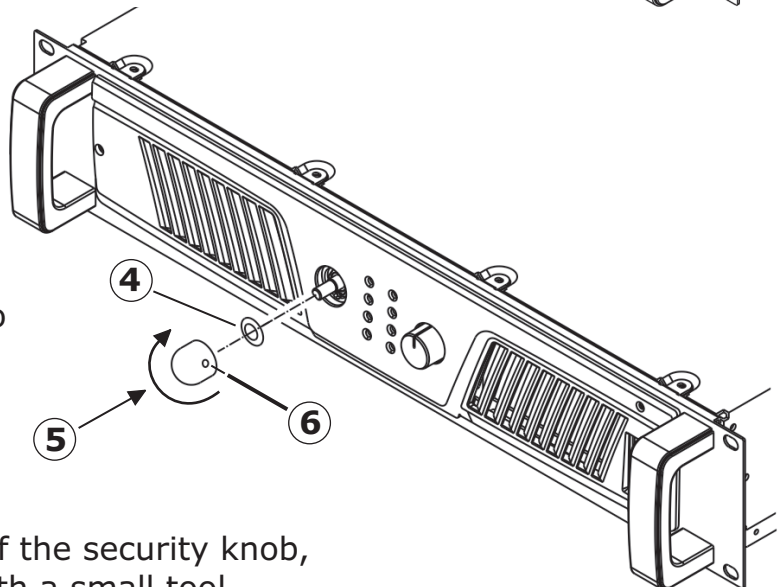

- ⑥ There are holes on the side of the security knob, which may be optionally used with a small tool to gently and minimally tighten the knob during installation, or to loosen the knob for removal later on.

Note: Over-tightening of the security knob will damage the potentiometer bushing on the amplifier. Any damage caused by over-tightening will be considered misuse and neglect.

DO NOT OVER-TIGHTEN.

Ashly Audio Inc
847 Holt Road, Webster, NY 14580
Toll Free (800) 828-6308, Telephone (585) 872-0010, FAX (585) 872-0739
www.ashly.com

All Rights Reserved



Ashly Audio Inc. LIMITED WARRANTY (USA ONLY)

(Other countries please contact your respective distributor or dealer.)

For units purchased in the USA, warranty service for this unit shall be provided by ASHLY AUDIO, INC. in accordance with the following warranty statement.

ASHLY AUDIO, INC. warrants to the owner of this product that it will be free from defects in workmanship and materials for a period of FIVE years from the original-date-of-purchase. ASHLY AUDIO INC. will without charge, repair or replace at its discretion, any defective product or component parts upon prepaid delivery of the product to the ASHLY AUDIO, INC. factory service department, accompanied with a proof of original-date-of-purchase in the form of a valid sales receipt. This warranty gives you specific legal rights, and you may also have other rights, which vary from state to state.

EXCLUSIONS: This warranty does not apply in the event of misuse, neglect, or as a result of unauthorized alterations or repairs made to the product. This warranty is void if the serial number is altered, defaced, or removed. ASHLY AUDIO, INC. reserves the right to make changes in design, or make additions to, or improvements upon, this product without any obligation to install the same on products previously manufactured.

Any implied warranties, which may arise under the operation of state law, shall be effective only for FIVE years from the original-date-of-purchase of the product. ASHLY AUDIO, INC. shall be obligated to only correct defects in the product itself. ASHLY AUDIO, INC. is not liable for any damage or injury, which may result from, or be incidental to, or a consequence of, such defects. Some states do not allow limitations on how long an implied warranty lasts, or the exclusion, or limitation of incidental or consequential damages, so the above limitations or exclusions may not apply to you.

OBTAINING WARRANTY SERVICE:

For warranty service in the United States, please follow this procedure:

1) Return the product to ASHLY AUDIO, INC. freight prepaid, with a written statement describing the defect and application that the product is used in. ASHLY AUDIO, INC. will examine the product and perform any necessary service, including replacement of defective parts, at no further cost to you.

2) Ship your product to:

ASHLY AUDIO, INC.
Attention: Service Department
847 Holt Road
Webster, NY 14580-9103

Ashly Audio Inc
847 Holt Road, Webster, NY 14580
Toll Free (800) 828-6308, Telephone (585) 872-0010, FAX (585) 872-0739
www.ashly.com

All Rights Reserved