



CSV28M

TWO-WAY, OAK FINISH
STAGE MONITOR SYSTEM

APPLICATIONS:

- Theatres
- Nightclubs
- Restaurants
- Houses of Worship
- Conference Rooms
- Concert Halls
- Cinema Surround Sound

FEATURES:

- High Output
- Ultra-Compact Low-Profile Enclosure
- PowerSense™ Dynamic Driver Protection
- Simulated Oak Laminate Exterior

DESCRIPTION

The CSV28M™ is a high output, super-compact, two-way stage monitor system. The system utilizes one PZT high frequency driver coupled to an exponential horn and one 12" woofer for high sensitivity and excellent power handling capability. These components are matched to an extremely low-profile enclosure of an optimally tuned, direct radiating, bass reflex design. The attractive oak laminate exterior, brown fabric grille, and recessed handles allow this system to be aesthetically integrated into its surroundings and be easily transportable.

The CSV28M offers a robust internal PowerSense DDP (Dynamic Driver Protection) crossover. The PowerSense crossover is built to last with high quality 250V film capacitors, inductors and military grade circuit boards. The proprietary PowerSense DDP circuit provides both over-current and thermal protection for added performance and reliability.

Designed as a high performance stage monitor, the CSV28M offers the clarity and detail necessary for critical live performance use. In addition, its smooth, peak-free response provides maximum gain before feedback ensuring capability for high on-stage sound pressure levels. The compact, low-profile design makes the CSV28M ideal for TV broadcast, house of worship and other applications where stage equipment must occupy little space, be visually attractive, and provide fully professional performance. Threaded T-nut inserts are provided plus an optional wall/ceiling bracket is available for permanent mounting for surround sound or other applications.

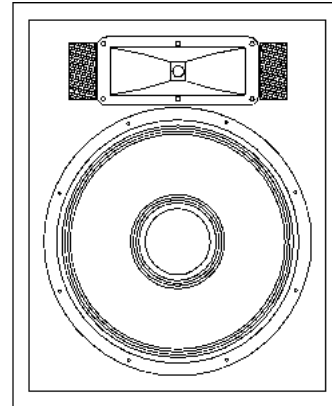

SPECIFICATIONS

Loudspeaker Type:

Two-Way, Full-Range, Stage Monitor System

Frequency Response: 70-18,000 Hz

Power Handling: 100W RMS 250W Program

Recommended Amp: 200W to 300W @ 8 Ohms

Sensitivity at 1W/1M: 97.5 dB

Nominal Dispersion: 90° x 60° (HxV)

Nominal Impedance: 8 ohms

Crossover Frequency: 3,000Hz

Drivers:

One PZT on an Exponential Horn

One 12" Woofer

Speaker Protection: PowerSense DDP

Input Connections:

Dual Neutrik Speakon in parallel

Dual 1/4" phone jacks in parallel

Enclosure Material:

Simulated Oak Laminate covered high density particle board

Brown fabric grille

Dimensions:

Height: 14 inches (356 mm)

Width: 15 inches (381 mm)

Depth: 22.25 inches (565 mm)

Front Slope: 35 Degrees from horizontal

Weight: 29 lbs. (13.2 kg.)

Shipping Weight: 37 lbs. (16.8 kg.)



CSV 28M

TWO-WAY, OAK FINISH
STAGE MONITOR SYSTEM

FREQUENCY RESPONSE

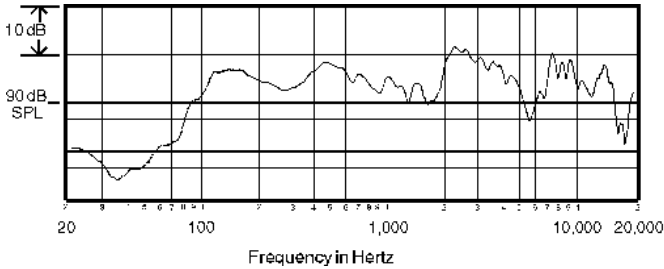

IMPEDANCE

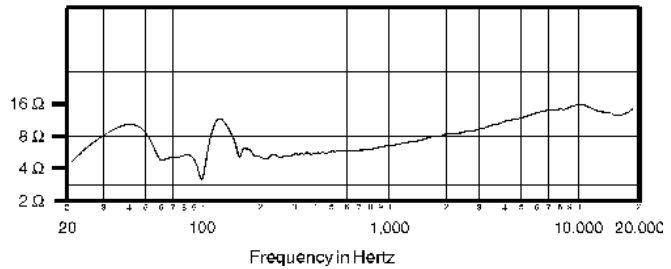

DIMENSIONS

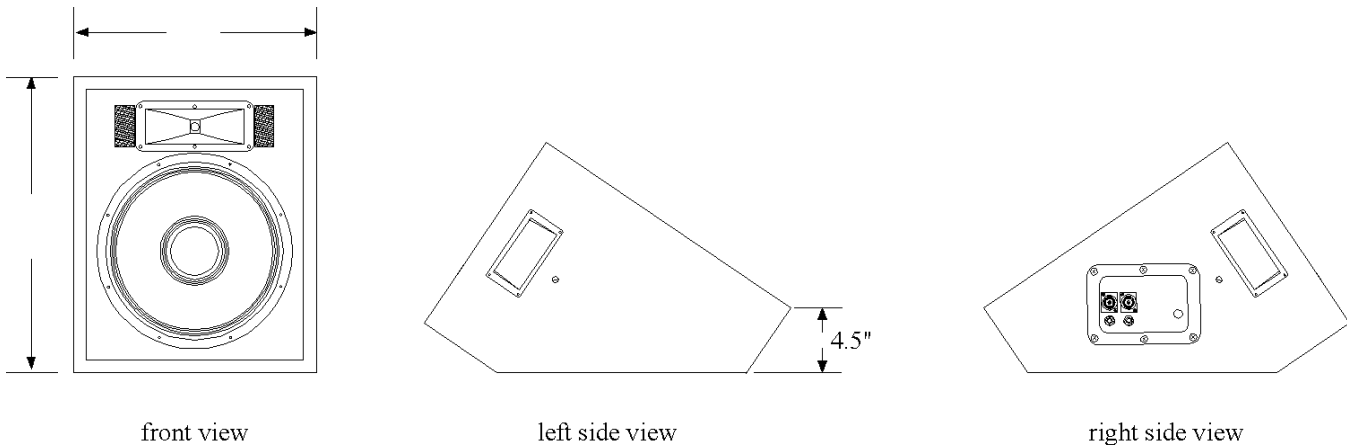

ARCHITECTS' AND ENGINEERS' SPECIFICATION

The loudspeaker system shall be a direct-radiating, slant-front, bass-reflex design with one 12" woofer and one PZT driver coupled to an exponential horn. All components shall be connected to an integral crossover/protector. The crossover/protector shall be a two-way design with a 12dB/octave high-pass at 3,000 Hz to the high frequency driver. The crossover shall utilize high quality 250V film capacitors, inductors and high positive current coefficient resistors (HPCCR's) for component protection. The loudspeaker enclosure shall have an internal volume of 0.98 cu. ft. (27.7 L) and be constructed of dense stock covered with a simulated oak laminate with two built-in handles. The system shall meet the following performance criteria: Amplitude response of 70 Hz to 18,000 Hz +/- 5 dB, 100W RMS power handling, 97.5 dB sensitivity at one meter with one watt applied. Coverage pattern shall be 90° x 60° (HxV). Dimensions shall be 14" (356 mm) H x 15" (381 mm) W x 22.25" (565 mm) D with a front slope of 35° from horizontal. The system impedance shall be 8 ohms nominal. It shall weigh 29 lb. (13.2 kg).

LIMITED WARRANTY

Community CSX/CSV Loudspeakers are guaranteed to be free from defects in materials and workmanship for a period of five years from the original date of sale. Since the warranty applies to the product, the remainder of the warranty period will be automatically transferred to any subsequent owner. Only failures caused by defects in materials and workmanship are covered, not failures caused by abuse, accident, modification, improper handling/installation, or repairs made without factory authorization or by other than an authorized Community Field Service Station. Products covered by this warranty will be repaired or replaced at the option of Community, without charge for materials or labor, provided all the terms of this warranty have been met. This statement is a condensed version of the Community Product Warranty, intended for quick reference only. For complete warranty information, consult the product owner's manual or call (610) 876-3400 for a copy.

Specifications subject to change without notice.

CSV28 Page 2 of 2

COMMUNITY PROFESSIONAL LOUDSPEAKERS

333 East Fifth Street Chester, PA 19013-4511 USA Phone (610) 876-3400 Fax (610) 874-0190

CV28-991020