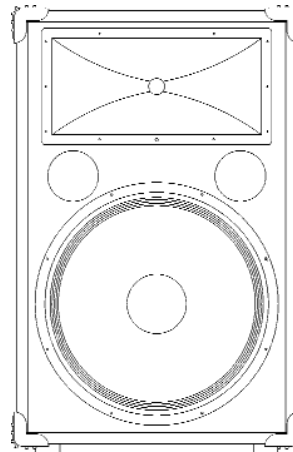

SPECIFICATIONS (See notes 1 and 2)

Loudspeaker Type:	Two-way, full-range
Operating Range:	60 Hz - 17 kHz 60 Hz - 15 kHz (+/-5dB)
Max Input Ratings:	200W continuous, 500W Program 40 volts RMS, 89 volts momentary peak
Recommended Power Amplifier:	For maximum SPL: 400W to 600W @ 8 Ohms
Sensitivity 1W/1m:	96 dB SPL (63 Hz - 13 kHz 1/3 octave bands) 94 dB SPL (250 Hz - 4 kHz speech range)
Maximum Output:	119 dB SPL / 126 dB SPL (peak)
Nominal Impedance:	8 Ohms
Min Impedance:	4 Ohms @ 11140 Hz
Nominal -6dB Beamwidth:	90° H (-10° / -50°, 1 kHz - 13 kHz) 40° V (+61° / -10°, 1 kHz - 12 kHz)
Axial Q / DI:	16.5 / 12.2, 1 kHz - 12 kHz
Crossover Frequency:	2 kHz
Recommended Signal Processing:	60Hz high pass filter
Drivers:	LF (1) 15" cast frame HF (1) LM20™ compression driver, non-metallic diaphragm, Ferrofluid-cooled
Driver Protection:	Thermal Link™
Input Connection:	(2) 1/4" jacks, (2) Locking Connectors
Controls:	None
Enclosure:	MDF
Enclosure Hardware:	(2) Recessed handles (8) Interlocking corner protectors (4) Rubber feet
Mounting / Rigging Provisions:	(1) 1-3/8" stand socket (6) 5/16-18 hanging point inserts
Grille:	16 gauge perforated steel
Required Accessories:	None
Supplied Accessories:	None
Optional Accessories:	Strapkit: (3) steel straps for suspending WB1: (2) steel plate brackets for wall mounting
Dimensions:	Height: 27.8" / 708 mm Width (front): 18" / 457 mm Width (rear): 12.4" / 315 mm Depth: 19" / 483 mm
Weight:	60 lb. / 27 kg
Shipping Weight:	73 lb. / 33 kg

1. Sensitivity: Free field pink noise measurement at 40 ft / 12.2 m at 50% power; extrapolated to 1 meter and an input of 2.83 volts RMS.
2. Watts: All wattage figures are calculated using the rated nominal impedance.

**APPLICATIONS:**

- SOUND REINFORCEMENT/PORABLE PA
- CLUBS/DJ
- BANDS
- HOUSES OF WORSHIP
- PERMANENT INSTALLATION
- SPORT FACILITIES & HEALTH CLUBS
- RENTAL SYSTEMS
- KARAOKE

FEATURES:

- SIGNAL PRESENT LED
- THERMAL LINK™ HF DRIVER PROTECTION
- LM20™ LOW MASS FERROFLUID-COOLED NON-METALLIC DIAPHRAGM
- DIE CAST ZINC STAND SOCKET
- HEAVILY BRACED MDF CONSTRUCTION
- TWO 1/4" INPUT CONNECTORS, AND TWO LOCKING CONNECTORS
- RECESSED HANDLES
- 16 GAUGE STEEL GRILLES

DESCRIPTION

The MVP36 is a rugged, high-efficiency, two-way, full-range loudspeaker system. The system utilizes one LM20™ high-frequency driver coupled to a Pattern Control horn and one 15" cast frame woofer for high efficiency and excellent power handling capability. These components are matched to an optimally tuned direct radiating bass-reflex enclosure. The recessed handles, black carpeted exterior and injection molded corners also make this system attractive and rugged.

The MVP36 offers a robust internal crossover with Thermal Link™ Dynamic HF Driver Protection. The crossover is built to last with high quality inductors, precision wound coils and military grade circuit boards. The proprietary Thermal Link Dynamic HF Driver Protection circuit provides both over-current and thermal protection for added performance and reliability.

Designed as a stand-alone full-range loudspeaker system, the MVP36 offers enough bass for most applications. For more demanding applications, extended bass can be achieved by adding a MVP subwoofer. Mounting is easily accomplished utilizing the threaded inserts provided and optional mounting kits. This product should never be suspended by its handles.

Frequency Response

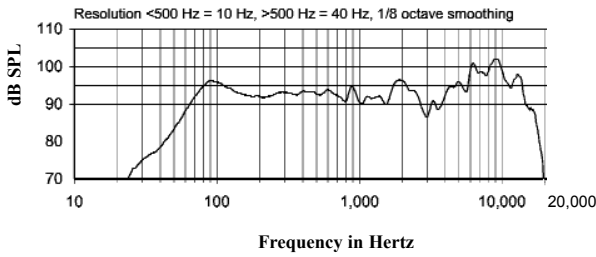

Impedance

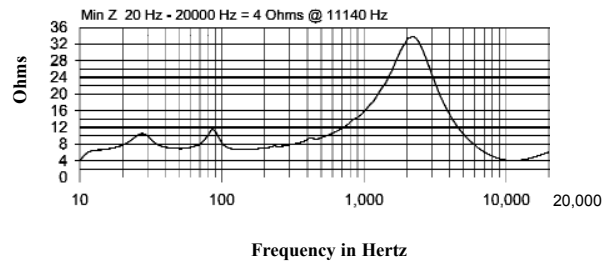

Beamwidth

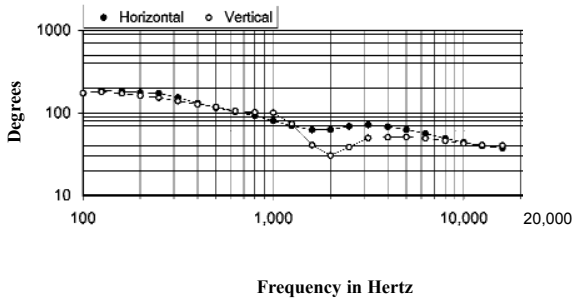

Axial Q

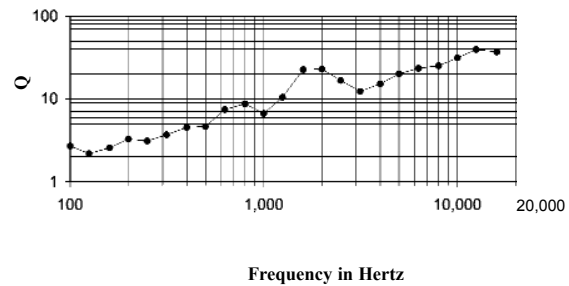

DIMENSIONS

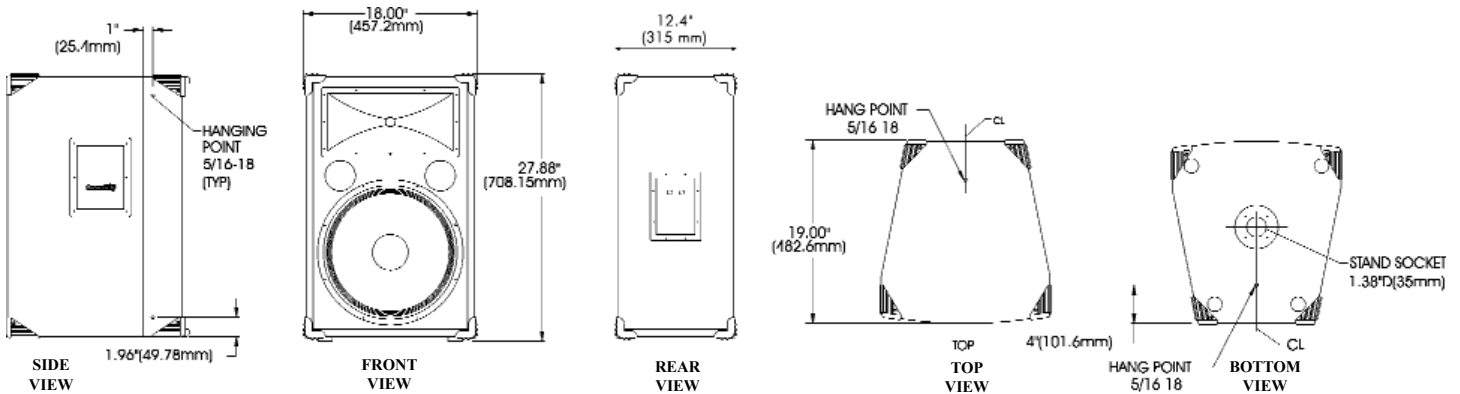

ARCHITECTS AND ENGINEERS SPECIFICATIONS

The loudspeaker system shall be a two-way, full-range bass reflex trapezoidal design with one 15" cast frame woofer and one 3/4" exit HF driver with a non-metallic diaphragm mounted to a 90° H x 40° V molded horn. Drivers shall be connected to an integral crossover with a crossover frequency of 2 kHz and a HF driver over-current and thermal protection circuitry. There shall be two 1/4" phone jacks and two locking connectors. The loudspeaker enclosure shall be black carpeted MDF construction with a 16 gauge perforated steel grille. The system shall have an amplitude response of 60 Hz to 15 kHz (+/- 5 dB), input capability of 40V RMS, 96 dB sensitivity at one meter and 2.83 V/8 ohms nominal impedance. The nominal dispersion shall be 90° H x 40° V from 1 kHz to 13 kHz. The loudspeaker shall be 27.8" (708 mm) H x 18" (457 mm) W (front) x 12.4" / 315 mm W (rear) x 19" (483 mm) D and weigh 60 lbs (27 kg).

LIMITED WARRANTY

Community MVP loudspeakers are guaranteed to be free from defects in materials and workmanship from the original date of sale for a period of five years in the U.S.A and worldwide. This warranty is automatically transferable to any and all owners during the specified period. For complete warranty information, consult the product owners manual or call (610) 876-3400 for a copy.