



# BOSE®

## FreeSpace® Model 32SE Surface-Mount Loudspeaker

### General Description

The Bose® FreeSpace Model 32SE loudspeaker is a 32-Watt loudspeaker designed for surface-mount installations in indoor and outdoor commercial spaces.

It offers the following features:

- A 4.5" (11.4 cm) Bose HVC (helical voice coil) environmental driver with active equalization, providing reliable high quality sound in a compact enclosure
- A multi-tap line transformer that provides easy-to-change tap settings for 1W, 2W, 4W, 8W, 16W, and 32W (available on 70V and 100V versions)
- Uses the same equalization as the Model 32 flush-mount and Model 25 loudspeakers
- Simple design available in black or white to blend with any decor or can be painted to match any interior
- Mounting hardware that permits fast and easy installation
- Weather-resistant design and hardware ensure reliable performance indoors or outdoors

### Installation

Hardware and installation instructions are included with the loudspeakers.

The loudspeakers may be mounted horizontally or vertically using the U-brackets, which attach to the side internal threaded inserts. The loudspeaker slips easily into the mounting bracket and can be tilted.



FreeSpace®  
BUSINESS MUSIC SYSTEMS

### Technical Information

#### Frequency Range

90Hz to 16kHz (±3dB)

#### Model 32SE Speaker Versions

##### Active Equalization

- 70V (1W, 2W, 4W, 8W, 16W, 32W taps)
- 100V (1W, 2W, 4W, 8W, 16W, 32W taps)

##### Passive Equalization

- 4Ω, 32W, no transformer

#### Sensitivity<sup>1</sup>

##### Active Equalization

86dB-SPL @ 1W, 1m (pink noise)

##### Passive Equalization

86dB-SPL @ 1W, 1m (pink noise)

#### Maximum Acoustic Output<sup>2</sup>

101dB-SPL @ 1m (pink noise)

101dB-SPL @ 1m (IEC<sup>3</sup> noise)

#### Dispersion (-6dB point, average, 1-4kHz)

132° conical

#### Long-Term Power Handling<sup>4</sup>

32W continuous

#### Mechanical Specifications

Dimensions: 6"H x 9"W x 5.6"D  
(15.2 cmH x 22.9 cmW x 14.1 cmD)

Weight: 5 lb (2.3 kg)

Connectors: 70V/100V, screw terminal; 4Ω, hex nut post terminals

Mounting Hardware Included: Quick install U-bracket and hardware

Additional Mounting Points: Two (2) 1/4"-20 inserts, 0.7 inch on bottom

<sup>1</sup>Full bandwidth pink noise is applied to the FreeSpace system controller and amplified to a level at the loudspeaker terminals corresponding to 1 Watt as referenced to the nominal impedance. The average sound pressure level (dB-SPL) is measured at 1 meter from the speaker in an anechoic environment.

<sup>2</sup>Full bandwidth pink noise is applied to the FreeSpace system controller and amplified to a level at the loudspeaker terminals corresponding to the long-term rated power handling of the speaker. The average sound pressure level (dB-SPL) is measured at 1 meter from the speaker in an anechoic environment.

<sup>3</sup>Full bandwidth pink noise, meeting Electrotechnical Commission (IEC) Standard #268-5, with a spectrum corresponding to average program material.

<sup>4</sup>Full bandwidth noise, meeting the IEC Standard #268-5 is applied to the FreeSpace system controller and amplified to a level at the loudspeaker terminals corresponding to the power handling of the loudspeaker. The loudspeaker must show no visible damage or measurable loss of performance after 100 hours of continuous testing.

## Views of Speaker with Bracket

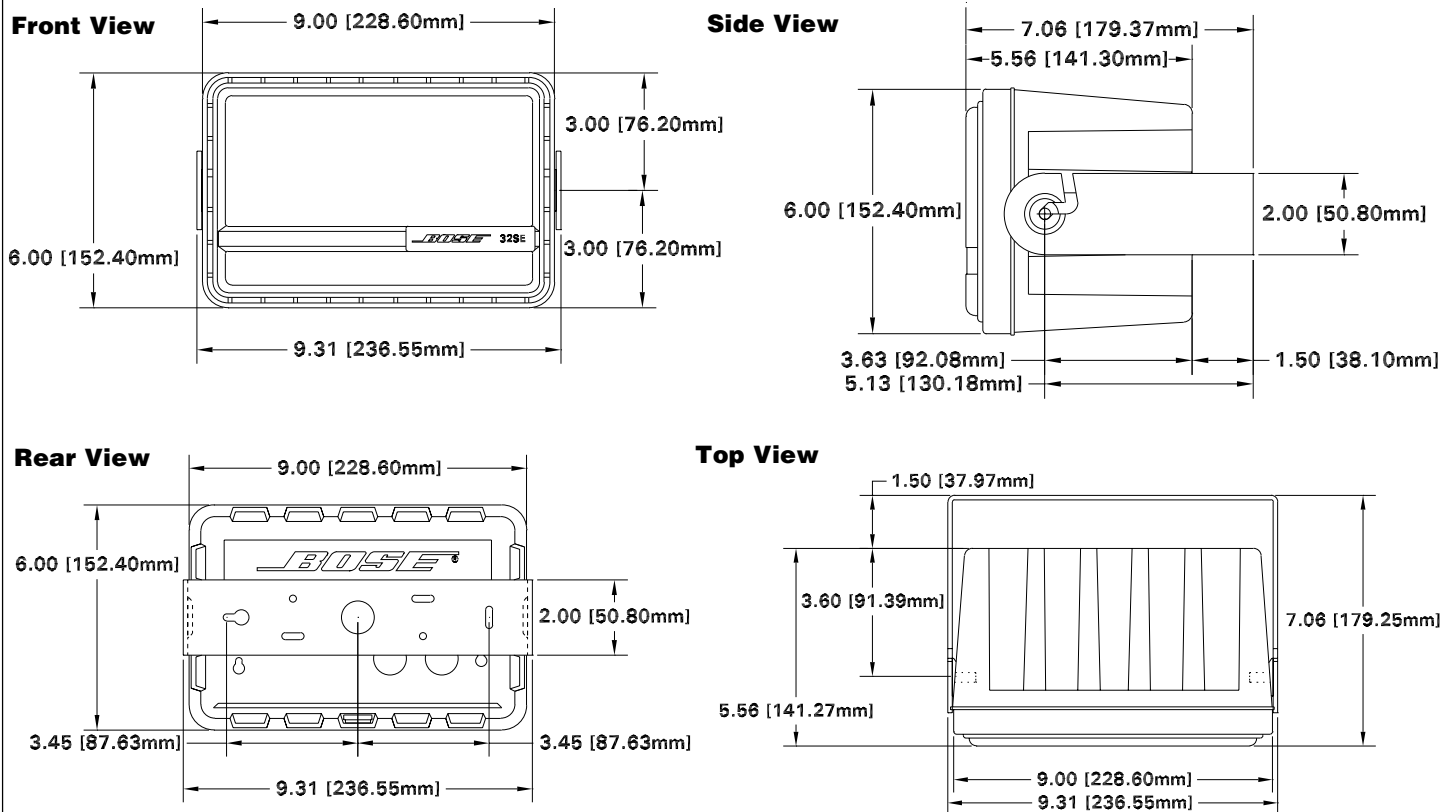

### Loudspeaker Configuration

Either the 70V or 100V version of the Model 32SE loudspeaker can be part of a distributed sound system when used in conjunction with any Bose® amplifier or when used with a FreeSpace® system controller and a comparable amplifier.

The 4Ω version is passively equalized and therefore does not require a controller.

All versions of the Model 32SE loudspeaker may be permanently installed in indoor or outdoor applications.

The Model 32SE loudspeaker is electrically and acoustically compatible with Model 32 loudspeakers. This permits a mix of FreeSpace Model 32SE and Model 32 loudspeakers to be connected to the Model 32 equalized amplifier output.

The Model 32SE is packaged two units per carton.

### Engineers' and Architects' Specifications

The loudspeaker is a 32-Watt, ported loudspeaker system utilizing one 4.5" (11.4 cm) HVC environmental full-range driver mounted on the frontal-facet baffle assembly. The driver shall have a rated impedance of 2Ω (except the 4Ω version) and shall be wired in parallel with a line voltage-matching (stepdown) transformer with level selector appropriate for various output taps. The 4Ω version is intended for direct connection to unequalized low impedance amplifier sources.

The loudspeaker shall have a twinported vent system, with a maximum acoustic output of 101dB-SPL from 90kHz to 16kHz, with measurements referenced to a full-bandwidth pink noise input at 1 meter at the loudspeaker's rated power. The input connection shall consist of a barrier strip "screw" type terminal. Its power handling capability shall be 1, 2, 4, 8, 16, or 32 Watts continuous power when referenced to IEC noise for 100 hours. The nominal dispersion shall be 132° at -6dB conical.

The loudspeaker shall be the Bose FreeSpace Model 32SE loudspeaker.

### Safety and Regulatory Compliance

All versions of the Bose FreeSpace Model 32SE loudspeaker are UL listed for safety and suitable for general purpose use. They comply with ANSI/EIA 636, *Recommended Loudspeaker Safety Practices* and EMC Directive 89/336/EEC and Article 10 (1) of the Directive in compliance with EN50081-1, EN50082-1, as signified by the CE mark.

### Warranty Information

All versions of the Bose FreeSpace Model 32SE loudspeaker are covered by a 5-year, transferable limited warranty.

**BOSE**  
Better sound through research.®

©2000 Bose Corporation, The Mountain,  
Framingham, MA 01701-9168  
255684 AM Rev.01 PC025131 JN00761