



APX20TN

TECHNICAL SPECIFICATIONS

Frequency Response:	400-7500 Hz (±6dB)
Power Rating:	
Model APX20TN:	20 Watts (continuous)
Model APX40TN:	40 Watts (continuous)
Sensitivity:	Model APX20TN 107dB 1 Watt/1 Meter (avg) 500-5000 Hz 118dB 20 Watts/1 Meter (avg) 500-5000 Hz 122dB 20 Watts (peak)
	Model APX40TN 107dB 1 Watt/1 Meter (avg) 500-5000 Hz 120dB 40 Watts/1 Meter (avg) 500-5000 Hz 124dB 40 Watts (peak)
Directivity Factor:	14 (2 kHz Octave Band)
Usable Low	
Frequency Limit:	350 Hz (see Fig. 3)
Dispersion Angle:	60° x 40° (+10 degrees)
Transformer:	25/70.7/100V
Voice Coil Diameter:	1.5" (38mm)
Magnet Weight:	8 oz. (.227 kg)
Flux Density:	13,000 Gauss, 1.3 Tesla
Construction:	UL94 Polycarbonate resin with UV light inhibitor added. Loudspeaker mounts to die-cast zinc base using a triple safety lock.
Finish:	Neutral grey
Dimensions:	14½"W x 10¼"H x 13¼"D (368 x 260 x 337mm)
Weight:	6 lbs. (2.7kg)

FEATURES

- Constant-Directivity Loudspeaker Offers Controlled
- Coverage of 60° x 40° Across a Wide Frequency Range for Predictable Beamwidth Control
- Choice of 20 and 40 Watt Models Provides Better Output Over Competitive 15 and 30-Watt Standards
- Triple Lock Horn-to-Base Mounting Method Speeds Installation and Insures Long-Term Stability
- Rotating Bell Pivots in 15° Increments for Exact On-Site Positioning of Projection Angles Detailed in Acoustic Simulation Programs
- Rear Cap Includes Partially-Captured Screws (No Loose Parts) for Swing-Open Access to Power Taps and Wire Connections. Cap Includes Knockout for Conduit Connection
- Sturdy Die-Cast Base Includes Provisions for Flex Conduit and May Be Mounted to 1-gang, 2-gang, and 4" Square E.O. Boxes, Banded to Poles or Removed for Easy Retrofit of Existing AP Series Loudspeakers
- Loudspeaker is Molded of High-Impact, Neutral-Grey Polycarbonate Resin with UV Light Inhibitor Preventing Embrittlement or Discoloration
- Universal 25/70/100V Transformer Includes a Rotary-Dial Selector for Easy Tap Identification
- Distinctive Blue Bands Identify Power from a Distance
- Speaker Mounting is Backwards Compatible to AP Series—Simply Remove Base and Mount to Omni-Purpose® Bracket
- Built-in Screen Protects Against Bug Nesting
- Multiple Patents Pending

APPLICATIONS

Atlas Sound, the most respected name in paging loudspeakers, offers Models APX20TN and APX40TN conservatively-rated, 20-watt and 40-watt, constant-directivity paging loudspeakers for use in public address or paging applications. They combine constant-directivity with superior engineering design, achieving extraordinary performance with quick and easy installation. These constant-directivity loudspeakers offer exact positioning flexibility with a simple twist of the wrist. The APX loudspeakers are well-suited for indoor applications including commercial, light industrial, and large retail/distribution applications where clear and pleasant indoor paging/communications and security are required. The speakers are also appropriate for installation in outdoor retail, commercial, recreational, and public use areas where dependable weatherproof performance is needed for communications and security. The neutral-grey finish compliments most interior or exterior surroundings. It may also be painted to match installation guidelines or cosmetics.

Specifications subject to change without notice



1601 JACK MCKAY BLVD. / ENNIS, TEXAS 75119 U.S.A. / TELEPHONE: (800) 876-3333 / FAX (800) 765-3435

Fig. 1

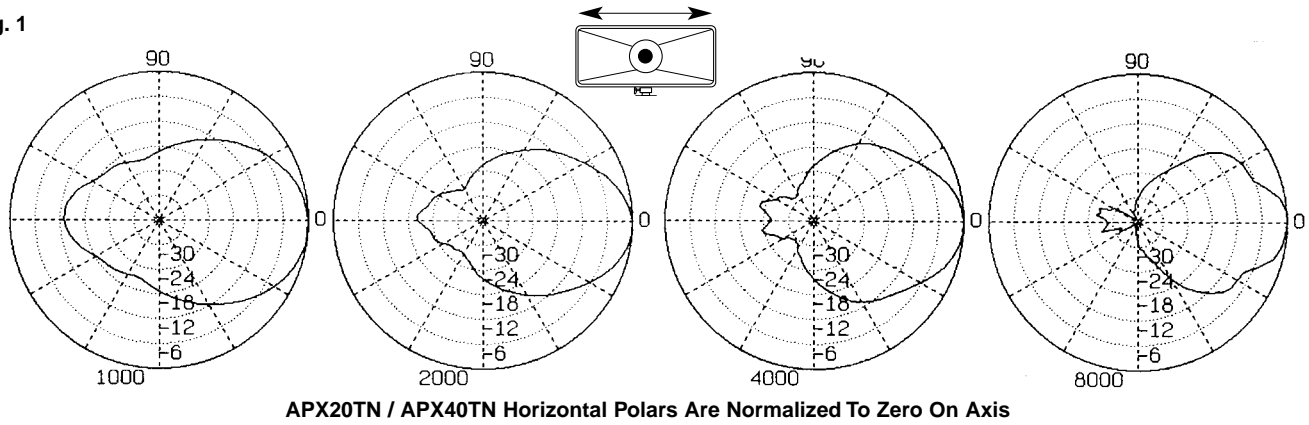
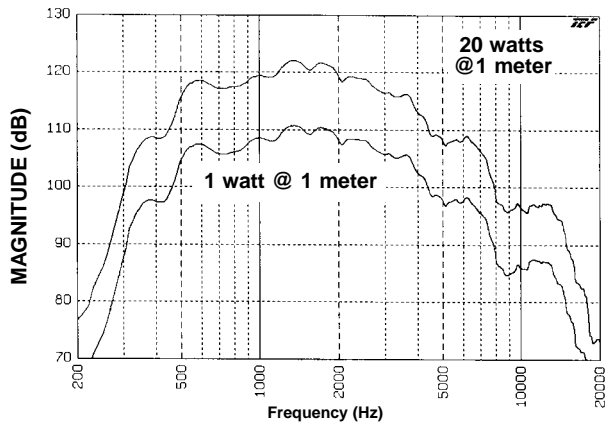
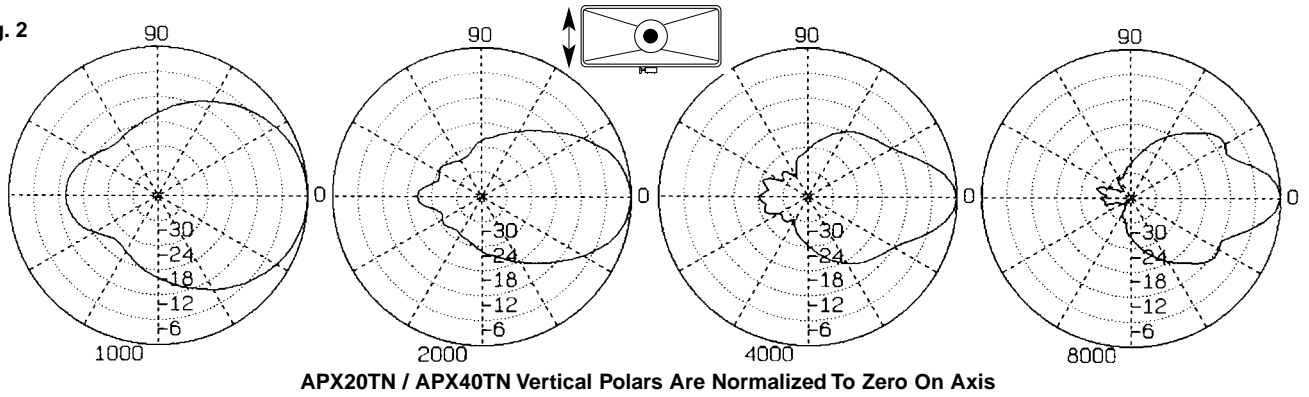

Fig. 2



APX20TN Frequency Response

Fig. 3

Fig. 4

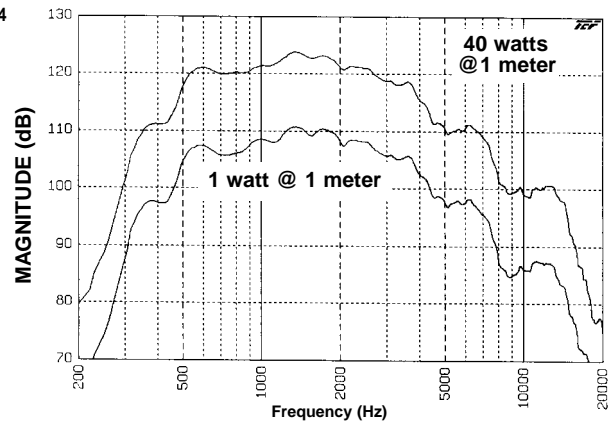

APX40TN Frequency Response

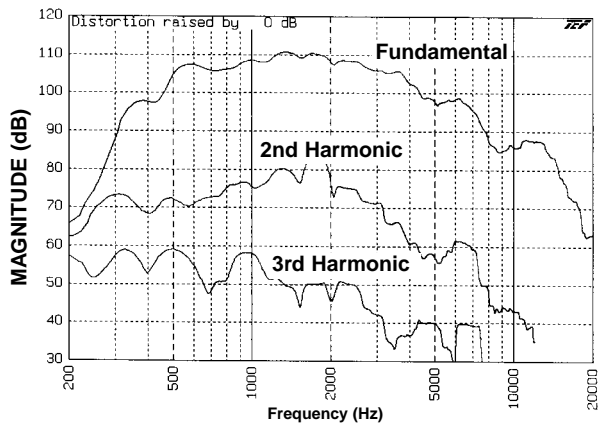

APX20TN / APX40TN (Harmonic Distortion - 2.83 watts @ 1 meter)

Fig. 6

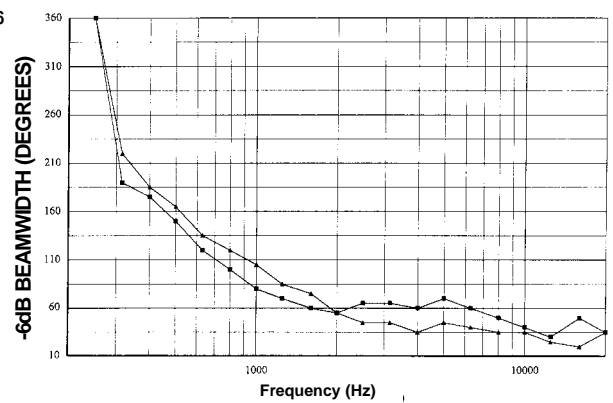

APX20TN / APX40TN Beamwidth

Specifications subject to change without notice



1601 JACK MCKAY BLVD. / ENNIS, TEXAS 75119 U.S.A. / TELEPHONE: (800) 876-3333 / FAX (800) 765-3435

Wire entrance slot may be enlarged with needle nosed pliers for larger jacketed cables.

Unique rotary dial identifies and sets the power taps on the 25/70/100V Xfmr.

Handy tap reference chart

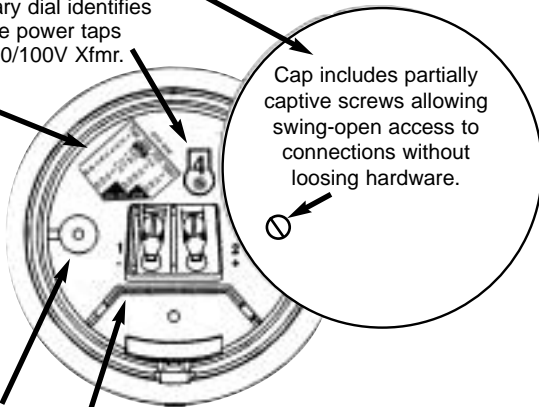

Cap includes partially captive screws allowing swing-open access to connections without loosening hardware.

Posts and notched barrier provide cable strain relief.

Fig. 9

Frequency (Hz)	Q	(dB) Di	Beamwidth (Degrees)	
			Horizontal	Vertical
500	6	7	120	140
1000	15	12	80	100
2000	26	14	60	60
4000	27	14	60	40
8000	36	16	50	40

Triple Lock Security

Loudspeaker quickly snap-locks to base to allow easy wiring connections, then secures with screws to withstand weather conditions and external forces that, traditionally, cause sagging or repositioning of the loudspeaker bell.

- ① Loudspeaker snap-locks to base sleeve
- ② Snap-lock Plastite® type screw secures assembly
- ③ Security cap screw-locks base between cap and speaker with (2) two screws

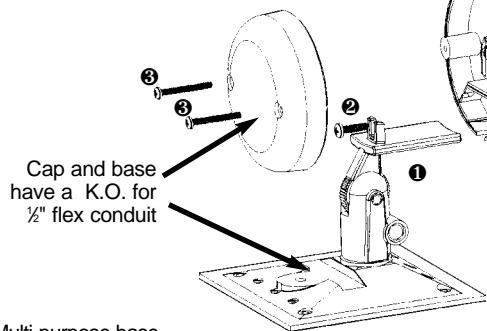

Cap and base have a K.O. for 1/2" flex conduit

Multi-purpose base accepts 1-gang, 2-gang or 4" Sq. E.O. Boxes in recessed, surface, indoor or outdoor styles.

The base may also be clamped or band mounted to poles or beams, removed for flush/bulkhead installation, or removed to retrofit existing speaker installations with AP Series Omni-Purpose® mount.

(See Other Side)

Fig. 7

Switch Position	Impedance (Ohms)	Watts @ 25V	Watts @ 70.7V	Watts @ 100V
1	4,000	-	1.25	2.5
2	2,000	-	2.5	5.0
3	1000	.63	5.0	10.0
4	500	1.25	10.0	20.0
5	333	1.88	15.0	X*
6	250	2.5	20.0	X*
7	125	5.0	X*	X*
8	62.5	10.0	X*	X*
9	31.3	20.0	X*	X*

(*Do Not Use)

Fig. 8

Switch Position	Impedance (Ohms)	Watts @ 25V	Watts @ 70.7V	Watts @ 100V
1	2,000	-	2.5	5.0
2	1,000	.63	5.0	10.0
3	500	1.25	10.0	20.0
4	250	2.5	20.0	40.0
5	167	3.75	30.0	X*
6	125	5.0	40.0	X*
7	62.5	10.0	X*	X*
8	31.3	20.0	X*	X*
9	15.6	40.0	X*	X*

(*Do Not Use)

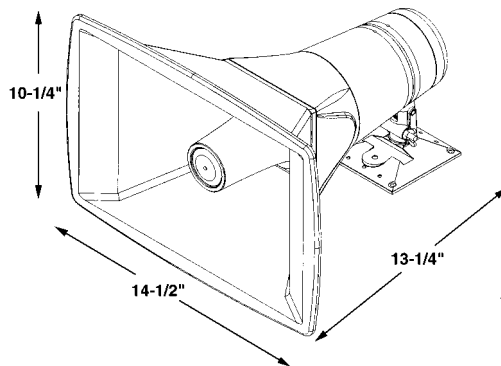
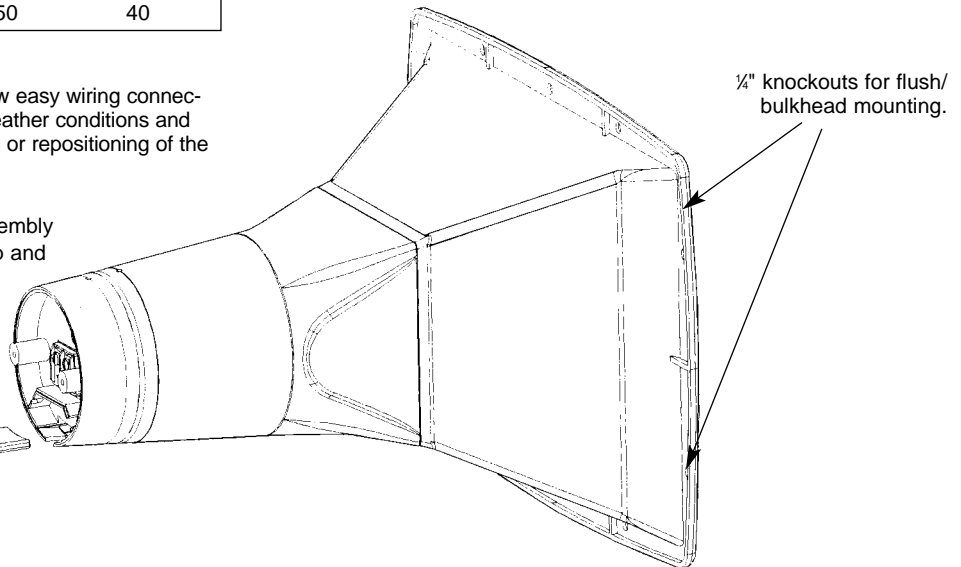

Rotating Bell
Lets you respond to specific coverage needs quickly in precise 15° increments. Allows full 360° rotation.

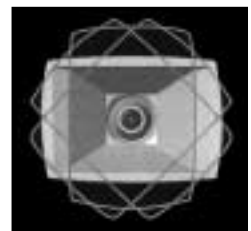

Note: All installation methods should carefully take into consideration loudspeaker assembly weight and environmental conditions.

Specifications subject to change without notice



1601 JACK MCKAY BLVD. / ENNIS, TEXAS 75119 U.S.A. / TELEPHONE: (800) 876-3333 / FAX (800) 765-3435

GENERAL DESCRIPTION

Performance

APX loudspeakers provide consistent beamwidth control in both horizontal and vertical directions—without guesswork—over a wide frequency range. This means clear messaging and music with less speakers and less cost. Models APX20TN and APX40TN offer 20 and 40-watts (respectively) of continuous power handling. They feature 60° x 40° (+10 degrees) constant-dispersion pattern across the controlled frequency band of 1.25-10K (horizontal) and 2-20K (vertical). The bell rotates in 15-degree increments (through full 360°) for precise projection angles. The frequency range is 400-7500 Hz (+6dB). Model APX20TN offers a peak SPL of 122dB at rated power and Model APX40TN has a peak SPL of 124dB at rated power. The loudspeaker's power rating is easy to recognize from a distance by the "power stripe" identification band around the driver assembly. One blue band equates to the 20-watt model and the 40-watt version displays two bands.

Connections

APX models are equipped with an internal 25/70.7/100-volt transformer with screw terminal connections made beneath the rear cap. The cap includes a wire slot and knockout to accommodate various sizes from 22-ga. to 14-ga. Romex®-type* or ½" flex conduit. Strain relief service loop options are provided via posts and notched barrier. Power taps are changed using a unique, screwdriver adjustable rotary switch with a nine-position dial indicator. The rear cap of an APX includes partially captured screws (no loose parts to drop). One screw may be loosened more than the other to allow swing open access to wire connections and power taps.

*Larger gauge jacket cable can be accommodated by enlarging the opening with needle nose pliers.

Mounting

Time and labor-saving mounting features make installation of the APX loudspeaker fast, easy, and economical. Pre-mount the die-cast zinc base to a standard U.S. 1-gang, 2-gang, or 4" sq. E.O. box. Base also includes provisions for strap-mounting the loudspeaker to poles or beams using hose clamps. After the base is secure, the loudspeaker snap locks to base sleeve for fast and easy wire connection. When connections are complete, simply insert sleeve screw and tighten the cap screws which will provide triple-lock security. This triple-lock mounting method will save installation time and keep the loudspeaker securely in place during extreme environmental conditions. Mounting accessories include an APX neutral color base/swivel assembly (APXBK-N), an APX base in grey (APXB-G), and an APX base only in neutral (APXB-N). In retrofit applications, if you are replacing Atlas Sound AP Series speakers, you may use the existing AP base for the APX Series. Simply unscrew wing nut on the APX to remove base and mount to AP bracket. (If neutral color AP base is desired, order XS8200601). Additionally, the bell includes ¼" knockouts for flush/bulkhead mounting in a box or to a wall. All installation methods should carefully take into consideration loudspeaker assembly weight and environmental conditions.

Construction

Designed and engineered to withstand wind and environmental exposure, the loudspeakers are molded of weather-resistant polycarbonate resin for years of performance reliability. The polycarbonate is combined with ultra-violet (UV) light inhibitor which enhances the loudspeaker's durable construction and adds to its longevity by preventing it from becoming brittle and discolored. APX models are reinforced with a smooth surface-mating collar which provides extra strength and a sleek appearance. The loudspeaker features a built-in screen located in front of the driver to protect against bug nesting. The neutral-gray units may be painted to match indoor or outdoor environments. Die-cast zinc base is painted to match the loudspeaker. Loudspeaker dimensions: 14½"W x 10¼"H x 13¼"D (368 x 260 x 337mm). It weighs 6 lbs. (2.7 kg).

ARCHITECT AND ENGINEER SPECIFICATIONS

Loudspeaker(s) shall be Atlas Sound Model _____ (APX20TN, APX40TN) or approved equal. Each loudspeaker shall be a constant-directivity type equipped with an integral compression driver. Sound-dispersion angle shall be 60 degrees x 40 degrees (+10 degrees) with a constant-dispersion pattern across the controlled frequency band of 1.25-10K (horizontal) and 2-20K (vertical). The tip of the loudspeaker shall loosen to allow bell to be rotated in 15-degree increments.

Model APX20TN shall have a power-handling capability of 20 watts continuous and Model APX40TN shall have a power handling capability of 40 watts continuous. Frequency response range shall be 400-7500 Hz (+6dB). SPL for Model APX20TN shall be 118dB (20W/1M), 107dB (1W/1M) and 122dB peak at 20 watts. APX40TN shall have a SPL of 120dB (40W/1M), 107dB (1W/1M), and 124dB peak at 40 watts.

The rear cap of the loudspeaker shall feature partially captured screws and swing open for access to the transformer with nine-position dial indicator rotary switch and wire connections. The cap shall include a slot and a knockout to accommodate connections using 22-ga. to 14-ga. wire or ½" flexible conduit. Wiring connections shall be made via enclosed terminal screws. Model APX20TN shall have impedance selection of 4000, 2000, 1000, 500, 333, 250, 125, 62.5, 31.3 ohms and accommodate 25, 70.7, or 100V line. Power taps shall be available at .63, 1.25, 1.88, 2.5, 5.0, 10.0, and 20 watts for 25V line; 1.25, 2.5, 5.0, 10.0, 15.0, and 20.0 watts for 70V line; and 2.5, 5.0, 10, and 20 watts for 100V line. Model APX40TN shall have impedance selection of 2000, 1000, 500, 250, 167, 125, 62.5, 31.3, and 15.6 ohms and accommodate 25, 70.7, or 100V line. Power taps shall be available at .63, 1.25, 2.5, 3.75, 5.0, 10.0, 20.0, and 40.0 watts for 25V line; 2.5, 5.0, 10.0, 20.0, 30.0, and 40.0 watts for 70V line; 5.0, 10.0, 20.0, and 40.0 watts for 100V line.

Loudspeakers shall feature a triple safety lock method of attaching to the base assembly via a snap-lock die-cast sleeve secured by a sleeve screw and two cap screws. It shall include a smooth surface mating collar for extra strength. Unit shall include a built-in screen within the loudspeaker to prevent bug nesting. The base shall be constructed of die-cast zinc and have provisions for flex conduit and mounting to a standard 1-gang, 2-gang, or 4" sq. E.O. box, or strap-mounting with hose clamps (by others). Additionally, the bell shall include ¼" knockouts for flush/bulkhead mounting in a box or to a wall. The base shall be powder-painted epoxy to match the loudspeaker and shall be paintable. Model APX20TN shall have one band around the back assembly to indicate a 20-watt unit and APX40TN shall feature two bands to indicate a 40-watt version. Loudspeaker assembly shall be environment-resistant, and constructed of heavy-duty, neutral-grey polycarbonate resin combined with ultra-violet (UV) light inhibitor. Dimensions shall be 14½"W x 10¼"H x 13¼"D (368 x 260 x 337mm). Weight shall be 6 lbs. (2.7 kg).

Specifications subject to change without notice



1601 JACK MCKAY BLVD. / ENNIS, TEXAS 75119 U.S.A. / TELEPHONE: (800) 876-3333 / FAX (800) 765-3435