

datavideo

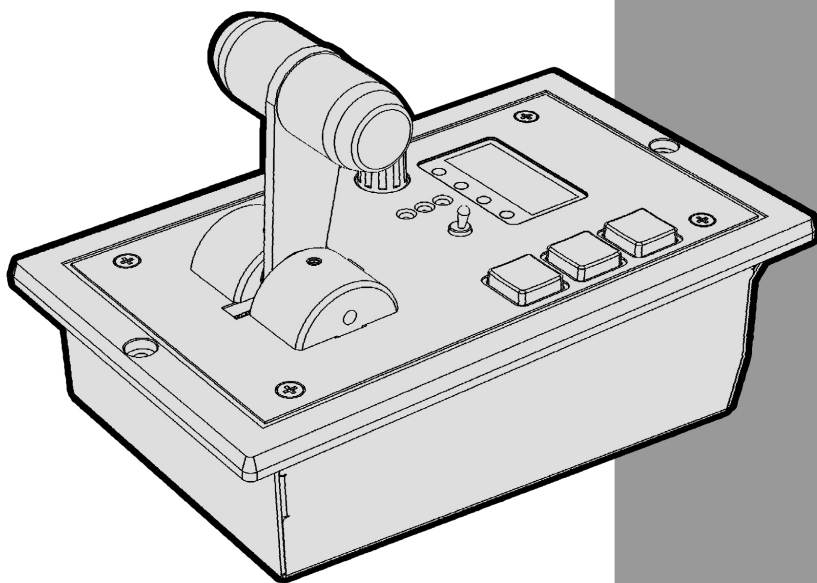

**IRIS/SHUTTER
CONTROL BOX
RMC-230**

Quick Start Guide

www.datavideo.com

Contents

Warnings and Precautions	3
Warranty	4
Standard Warranty	4
Two Year Warranty	4
Disclaimer of Product & Services	5
Disposal.....	5
Packing List.....	5
Product Overview	6
Features	6
System Diagram.....	7
Control Panel	9
Rear Panel	11
Firmware Upgrade	12
Dimensions	13
Frequently-Asked Questions.....	14
Specifications	15
Service & Support.....	16

Warnings and Precautions

1. Read all of these warnings and save them for later reference.
2. Follow all warnings and instructions marked on this unit.
3. Unplug this unit from the wall outlet before cleaning. Do not use liquid or aerosol cleaners. Use a damp cloth for cleaning.
4. Do not use this unit in or near water.
5. Do not place this unit on an unstable cart, stand, or table. The unit may fall, causing serious damage.
6. Slots and openings on the cabinet top, back, and bottom are provided for ventilation. To ensure safe and reliable operation of this unit, and to protect it from overheating, do not block or cover these openings. Do not place this unit on a bed, sofa, rug, or similar surface, as the ventilation openings on the bottom of the cabinet will be blocked. This unit should never be placed near or over a heat register or radiator. This unit should not be placed in a built-in installation unless proper ventilation is provided.
7. This product should only be operated from the type of power source indicated on the marking label of the AC adapter. If you are not sure of the type of power available, consult your Datavideo dealer or your local power company.
8. Do not allow anything to rest on the power cord. Do not locate this unit where the power cord will be walked on, rolled over, or otherwise stressed.
9. If an extension cord must be used with this unit, make sure that the total of the ampere ratings on the products plugged into the extension cord do not exceed the extension cord's rating.
10. Make sure that the total amperes of all the units that are plugged into a single wall outlet do not exceed 15 amperes.
11. Never push objects of any kind into this unit through the cabinet ventilation slots, as they may touch dangerous voltage points or short out parts that could result in risk of fire or electric shock. Never spill liquid of any kind onto or into this unit.
12. Except as specifically explained elsewhere in this manual, do not attempt to service this product yourself. Opening or removing covers that are marked "Do Not Remove" may expose you to dangerous voltage points or other risks, and will void your warranty. Refer all service issues to qualified service personnel.
13. Unplug this product from the wall outlet and refer to qualified service personnel under the following conditions:
 - a. When the power cord is damaged or frayed;
 - b. When liquid has spilled into the unit;
 - c. When the product has been exposed to rain or water;
 - d. When the product does not operate normally under normal operating conditions. Adjust only those controls that are covered by the operating instructions in this manual; improper adjustment of other controls may result in damage to the unit and may often require extensive work by a qualified technician to restore the unit to normal operation;
 - e. When the product has been dropped or the cabinet has been damaged;
 - f. When the product exhibits a distinct change in performance, indicating a need for service.

Warranty

Standard Warranty

- Datavideo equipment is guaranteed against any manufacturing defects for one year from the date of purchase.
- The original purchase invoice or other documentary evidence should be supplied at the time of any request for repair under warranty.
- Damage caused by accident, misuse, unauthorized repairs, sand, grit or water is not covered by this warranty.
- All mail or transportation costs including insurance are at the expense of the owner.
- All other claims of any nature are not covered.
- Cables & batteries are not covered under warranty.
- Warranty only valid within the country or region of purchase.
- Your statutory rights are not affected.



Two Year Warranty

- All Datavideo products purchased after 01-Oct.-2008 qualify for a free one year extension to the standard Warranty, providing the product is registered with Datavideo within 30 days of purchase. For information on how to register please visit www.datavideo.com or contact your local Datavideo office or authorized Distributors
- Certain parts with limited lifetime expectancy such as LCD Panels, DVD Drives, Hard Drives are only covered for the first 10,000 hours, or 1 year (whichever comes first).

Any second year warranty claims must be made to your local Datavideo office or one of its authorized Distributors before the extended warranty expires.

Disclaimer of Product & Services

The information offered in this instruction manual is intended as a guide only. At all times, Datavideo Technologies will try to give correct, complete and suitable information. However, Datavideo Technologies cannot exclude that some information in this manual, from time to time, may not be correct or may be incomplete. This manual may contain typing errors, omissions or incorrect information. Datavideo Technologies always recommend that you double check the information in this document for accuracy before making any purchase decision or using the product. Datavideo Technologies is not responsible for any omissions or errors, or for any subsequent loss or damage caused by using the information contained within this manual. Further advice on the content of this manual or on the product can be obtained by contacting your local Datavideo Office or dealer.

Disposal

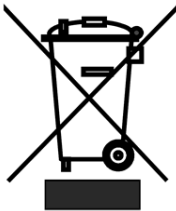

For EU Customers only - WEEE Marking

This symbol on the product indicates that it will not be treated as household waste. It must be handed over to the applicable take back scheme for the recycling of Waste Electrical and Electronic Equipment. For more detailed information about the recycling of this product, please contact your local Datavideo office.

Packing List

The following items should be in the box. If any items are missing please contact your supplier.

Item No.	Description	Quantity
1	RMC-230 Unit	1
2	Accessory List	1

Product Overview

The main design purpose of the RMC-230 is to replace camera iris and shutter control on MCU-100S and MCU-200S. It acts as an interface connected between an MCU unit and the cameras. One end of the RMC-230 is connected to the camera via AD-1S and another end of the RMC-230 is connected to the MCU units, which are cost effective remote controllers designed specifically for remote control of SONY video cameras and camcorders. However, the RMC-230 can also be used as a standalone device for just controlling the camera iris and shutter as shown in the diagram below.

That's Datavideo, sharing the value!

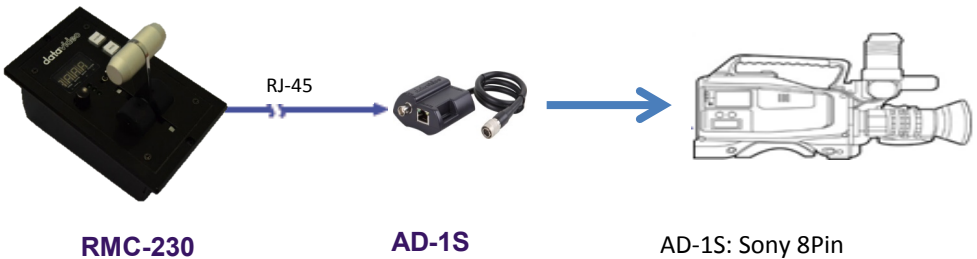

Features

- Two RJ-45 ports allow connections of one end of RMC-230 to AD-1 and another end of RMC-230 to MCU-100 Unit.
- Two PWR ports with one providing power connection and another one allowing cascade of multiple RMC-230 units.
- Control of Shutter adjustment.
- Control of Iris adjustment.
- Iris and Shutter level display

System Diagram

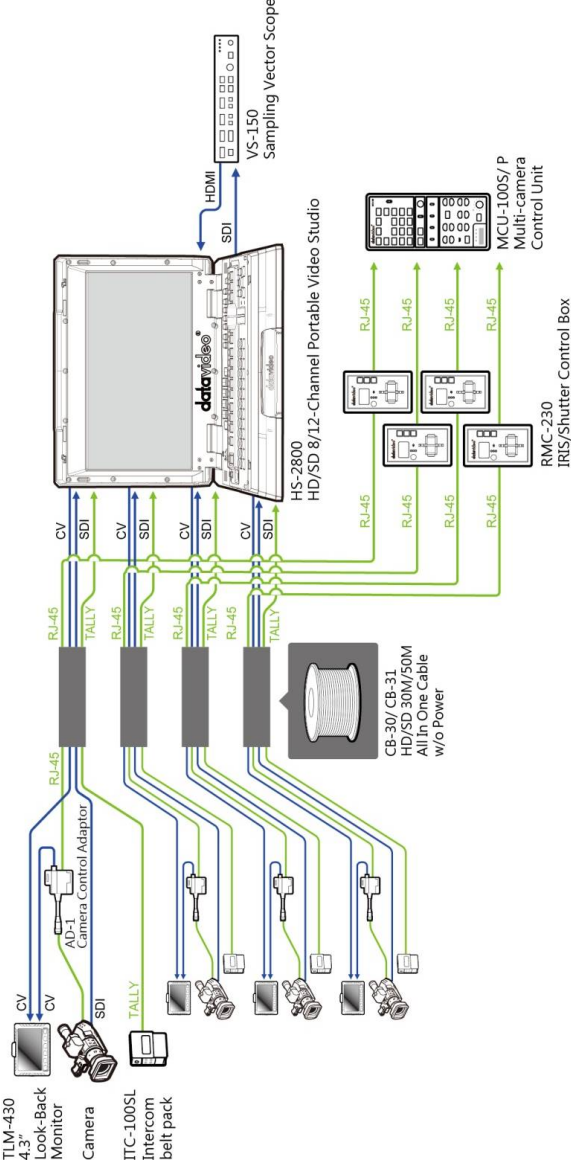

Power cascade of multiple RMC-230 Units

Connection to MCU-100/200

1. Use Cat. 5e cable to connect one RJ-45 connector of MCU-100/200 to the RJ-45 connector of the RMC-230
2. Connect the RJ-45 connectors of the RMC-230 and AD-1 via Cat. 5e cable.
3. The DC power adaptor must be connected to the first RMC-230 unit. If the user has to connect the second or the third unit, the user can use the DC power cable to cascade the units using another power connector. The user is also allowed to connect each RMC-230 unit to the DC power independently.

Connection to MCU-100S / 200S

1. Do not need to connect power adaptor to the RMC-230 as the RMC-230 is powered by Cat. 5e cable.
2. Use Cat. 5e cable to connect the RJ-45 connector of MCU-100S or MCU-200S to RJ-45 connector of the RMC-230
3. Connect RJ-45 connectors of the RMC-230 and AD-1 via Cat. 5e cable.

Control Panel

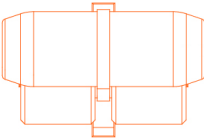
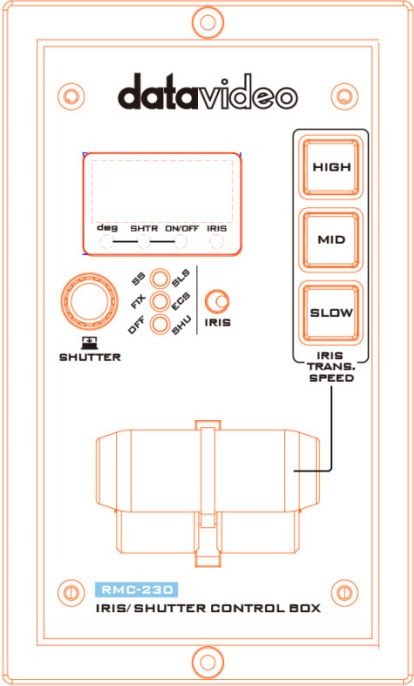

T-Bar
Adjustment of iris value



High iris transition speed button
High iris transition speed



Medium iris transition speed button
Medium iris transition speed



Slow iris transition speed button

Slow iris transition speed



7-Segment Display Screen

Displays Iris and Shutter values

LEDs

IRIS ON: Manual mode

IRIS OFF: Auto mode

ON: SONY camera shutter ON

OFF: SONY camera shutter OFF

SHTR ON: Shutter speed display

SHTR OFF: IRIS value display

Deg ON: Shutter angle is displayed

Deg OFF: Shutter speed is displayed



Shutter knob

Adjustment of shutter speed for SONY cameras

Press the knob to turn off the SONY camera shutter mode



Toggle Switch

Toggle Right: Switches between auto and manual IRIS modes

Toggle Left: Switches between different shutter modes (SONY camera: SLS/ECS/SHU)



LED Indicators for shutter modes

SONY camera: SLS/ECS/SHU

Rear Panel

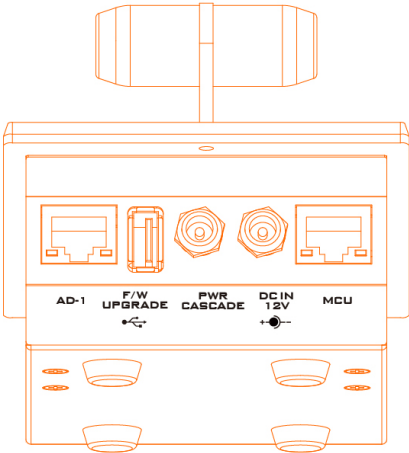

RJ-45 Port (AD1)
Connection to AD1



USB Port
Connection to the PC for F/W Upgrade



PWR Cascade
Powers another RMC-230 to cascade multiple RMC-230s



DC-IN 12V
Power supply



RJ-45 Port (MCU)
Connection to MCU

Firmware Upgrade

Datavideo usually releases new firmware containing new features or reported bug fixes from time to time. Customers can either download the firmware from our official website or contact their local dealer or reseller for assistance.

This section outlines the firmware upgrade process.

1. Turn off the RMC-230.
2. Connect the RMC-230 to the PC via USB cable.



3. Press and Hold the shutter button  .
4. Turn on the RMC-230.
5. 7-segment display of the RMC-230 will display “L-0.5”, and the PC will detect the RMC-230 and recognize it as a USB device.
6. Open the “RMC-230_U1” disk drive on the PC.
7. Remove the binary file (fw_0v500.bin) from the “RMC-230_U1” folder.
8. Copy new binary file to the “RMC-230_U1” disk drive.
9. Reboot RMC-230 to complete the firmware update.

Dimensions

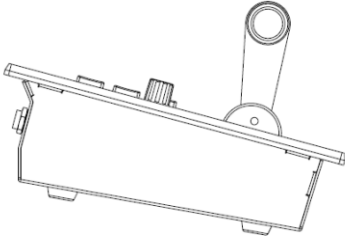
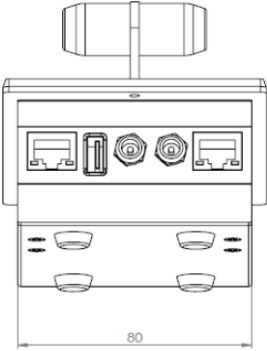
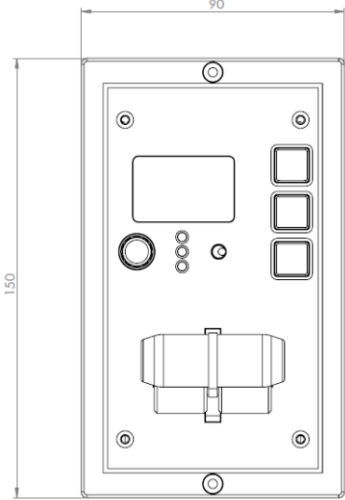

All measurements in millimetres (mm)

Frequently-Asked Questions

This section describes problems that you may encounter while using RMC-230. If you have questions, please refer to related sections and follow all the suggested solutions. If problem still exists, please contact your distributor or the service center.

No.	Problems	Solutions
1.	What is the maximum recommended length of Cat. 5e cable for the connection between RMC-230 and MCU-100 Unit?	The maximum recommended length of Cat. 5e is 50 meters.

Specifications

Input/Output Connection	RJ-45 x 2
Power Jack	DC IN x 1 Power Cascade x 1
F/W Upgrade	USB x 1
Display	7-segment Display and LED
Power	DC 12V
Environmental Conditions	Operating temperature. : 0~50°C Storage temperature : -10~60°C
Dimension	150 x 90 x 97.6mm
Weight	0.6kg

Service & Support

It is our goal to make your products ownership a satisfying experience. Our supporting staff is available to assist you in setting up and operating your system. Please refer to our web site www.datavideo.com for answers to common questions, support requests or contact your local office below.

Datavideo Taiwan

Datavideo Technologies Co. Ltd
10F, No. 176, Jian 1st Rd., Chung Ho District, New Taipei City 235, Taiwan, R. O. C.
Tel: +886-2-8227-2888
Fax: +886-2-8227-2777
E-mail: service@datavideo.com.tw

Datavideo USA

Datavideo Corporation
7048 Elmer Avenue.
Whittier, CA 90602,
U. S. A.
Tel: +1-562-696 2324
Fax: +1-562-698 6930
E-mail: sales@datavideo.us

Datavideo Hong Kong

Datavideo Hong Kong Ltd
G/F, 26 Cross Lane
Wanchai, Hong Kong
Tel: +852-2833-1981
Fax: +852-2833-9916
E-mail: info@datavideo.com.hk

Datavideo Europe

Datavideo Technologies Europe BV
Floridadreef 106
3565 AM Utrecht,
The Netherlands
Tel: +31-30-261-96-56
Fax: +31-30-261-96-57
E-mail: info@datavideo.nl

Datavideo China

Datavideo Technologies China Co
101, NO. 618, LiuYing Rd, Zhabei District, Shanghai, China
Tel: +86 21-5603 6599
Fax: +86 21-5603 6770
E-mail: service@datavideo.cn

Datavideo France

Datavideo France s.a.r.l
Cité Descartes 1, rue Albert Einstein
Champs sur Marne
774477-Marne la Vallée cedex 2
Tel: +33-1-60370246
E-mail: info@datavideo.fr

Datavideo United Kingdom

Datavideo UK Limited
Units 1 & 2 Waterside Business Park
Hadfield, Glossop, Derbyshire
SK13 1BE, UK
Tel: +44-1457 851 000
Fax: +44-1457 850 964
E-mail: sales@datavideo.co.uk

Datavideo Singapore

Datavideo Technologies (S) PTE Ltd
No. 178 Paya Lebar Road #06-03
Singapore 409030
Tel: +65-6749 6866
Fax: +65-6749 3266
E-mail: sales@datavideo.sg

Datavideo India

Datavideo Technologies India Pvt Ltd
A-132, Sec-63, Noida-201307,
Uttar Pradesh (UP), India.
Tel: +91-0120-2427337
Fax: +91-0120-2427338
E-mail: sales@datavideo.in



Please refer to our website for update the latest version manual.
www.datavideo.com/Camera+Control/RMC-230

datavideo

www.datavideo.com

All the trademarks are the properties of their respective owners. Datavideo Technologies Co., Ltd. All rights reserved 2018

Feb-06.2015 P/N: G082060726B1