



Description

As a quasi three-way, full-range loudspeaker system, the W2-228 provides three-way performance in a compact form-factor. It includes 8" LF and 8" MF / LF cones made of carbon fiber. The coaxially-mounted 1" HF driver has a weather-resistant, non-metallic, non-resonant polyimide diaphragm. Drivers are Ferrofluid-cooled to improve heat transfer, resulting in higher power handling and reduced distortion.

The W2-228 is ideal for short throw applications where both full-range reproduction and high weather-resistance are needed, providing an uncompromised musical system in a compact, attractive package.

Engineered for permanent installation, the loudspeaker enclosure and faceplate are constructed of multi-layer glass composite, resulting in extreme structural strength. A three-layer Weather-Stop™ grille provides weather-resistance to the internal components, while all exposed hardware is stainless steel or powder-coated aluminum extrusion. A weather-resistant stainless steel mounting yoke is included.

An optional "autoformer" version (model W2-228T) is available, with a built-in 200-watt autoformer for 70V/100V lines with selectable taps at 200W, 100W, 50W and 25W.

The W2-228 is backed by a five-year product warranty plus a fifteen-year enclosure warranty.

Applications

- Theme and Amusement Parks
- Outdoor Entertainment Centers
- Cruise Ships
- Stadium Fill
- Music Pavilions
- Musical Fountains
- Water Parks

Features

All-Weather, Multilayer Glass Composite Enclosure

Weather Inert Driver Diaphragms

Stainless Steel Hardware

Integral Mounting Points

High Power Passive Crossover

Ferrofluid-Cooling

Dual-layer Powder Coated Weather-Resistant Stainless Steel Grille and Yoke

Available in Black or White Finishes

Available with built-in 200W Autoformer for 70V / 100V Applications

Mounting Yoke Included

W2-228

WET SERIES II FULL-RANGE
QUASI 3-WAY, 8-INCH

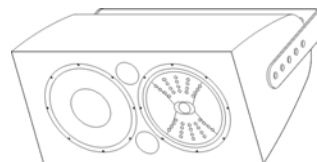

SYSTEM

Format: Quasi three-way, wide angle, full-range

Operating Range: 70 Hz - 18 kHz

Frequency Response: 80 Hz - 15 kHz (± 3 dB)

Dispersion (-6 dB): 85° H x 85° V

Maximum SPL @ 1m: 120 dB continuous / 127 dB peak

Crossover Frequency: 2 kHz

Sensitivity in SPL: 96 dB (100 Hz - 13 kHz, 1/3 octave)
96 dB (250 Hz - 4 kHz, speech range)

Max Power Handling: 250W RMS
600W Program

Autoformer Version:
70V Taps: 200W, 100W, 50W and 25W
100V Taps: 200W, 100W and 50W

Impedance: Nominal 4 Ω / 3.2 Ω at 180Hz

TRANSDUCERS

Low Frequency: 8" Carbon Fiber (203 mm)

Low/Mid-Frequency: 8" Carbon Fiber (203 mm)

High Frequency: 1" Non-Metallic (25.4 mm)

MECHANICAL

Enclosure: Hand-laminated fiberglass

Finish: Black or white gelcoat

Rigging Provisions: Two 1/2-13 rigging points; yoke bracket included

Input Connection: 16-2 SJOW (12 ft / 4m)
18-5 SJOW T-Version

Grille: Three-layer Weather-Stop™

Dimensions: 10.13" (257 mm) x 20" (508 mm) x 11.5" (292 mm)

Net Weight: 36 lbs / 16.3 kg

Recommended signal processing available at communitypro.com.

FREQUENCY RESPONSE

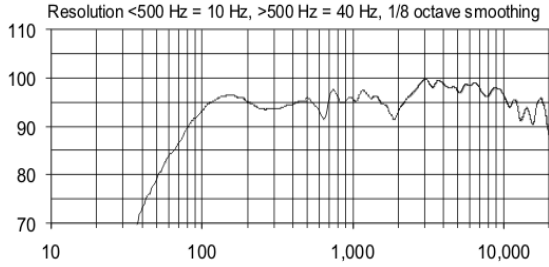

IMPEDANCE

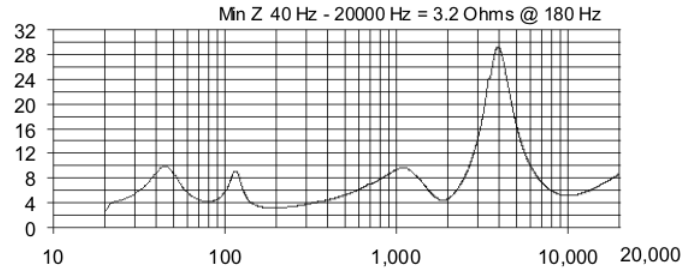

AUTOFORMER 200W IMPEDANCE

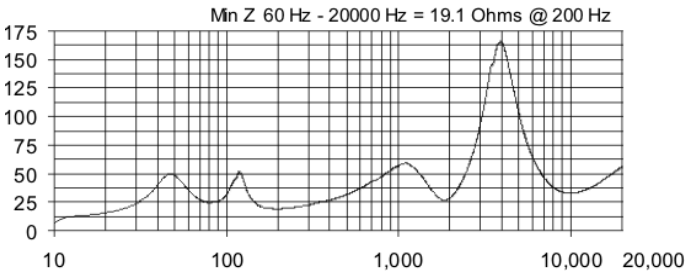

BEAMWIDTH

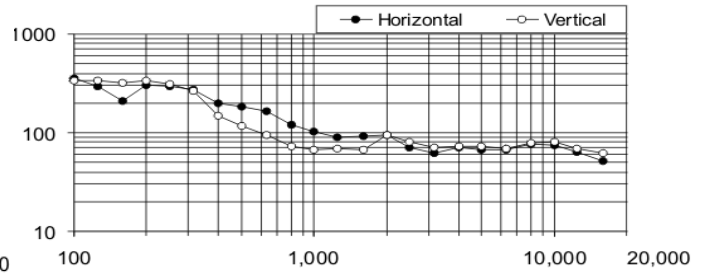

AXIAL Q

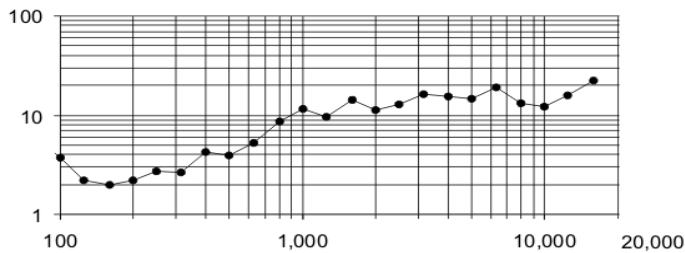

YOKE

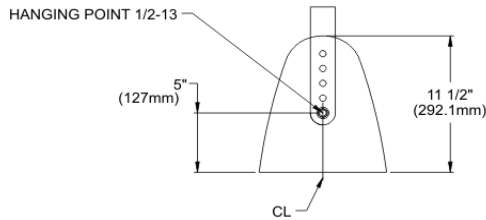
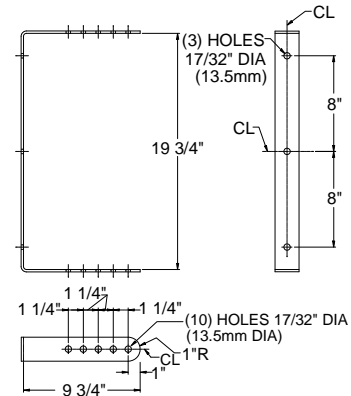

TOP

SIDES

FRONT

BACK

Architects' and Engineers' Specifications

The loudspeaker system shall be a full-range, three-way weather-resistant bass reflex design with one 8-inch carbon fiber low frequency woofer, one 8-inch carbon fiber low/mid frequency woofer and one 1-inch exit high frequency driver with a non-metallic diaphragm coaxially mounted on a fiberglass high frequency horn. Drivers shall be connected to an integral crossover with crossover frequency of 2 kHz and integral over-current protection circuitry using high positive current coefficient resistors. The input connection shall be one 12 foot (4m) SJOW #16 gauge cable with stripped ends. The loudspeaker enclosure shall be of molded reinforced fiberglass with a 16 gauge perforated steel grille. There shall be two 1/2 - 13 rigging points. The system shall have an amplitude response of 80 Hz - 15 kHz (+/- 3 dB), input capability of 32 volts RMS, 96 dB sensitivity at one meter / 2 V / 4 ohms nominal impedance. The nominal dispersion shall be 85° H x 85° V from 2 kHz - 12.5 kHz. The loudspeaker shall be 10.13 in. (257 mm) high x 20 in. (508 mm) wide x 11.5 in. (292 mm) deep and weigh 36 lbs (16.3 kg).

Community strives to improve its products on a continual basis. Specifications are therefore subject to change without notice.