

# LSR6312SP

## Linear Spatial Reference Powered Studio Subwoofer System

### Key Features:

- ▶ Multi-format powered subwoofer for Dolby Prologic, AC-3, DTS and other surround formats.
- ▶ RMC™ Room Mode Correction provides electronic control of response peaks due to room modes. RMC calibration kit included.
- ▶ 250 watt continuous output power amplifier.
- ▶ Sophisticated LCR bass management system.
- ▶ Direct LFE input with selectable 10 dB input sensitivity.
- ▶ Summed output allows chaining of multiple LSR6312SP for multiple subwoofer systems.
- ▶ Neodymium Differential Drive NDD™ technology with dynamic braking for extended low frequency response and low power compression.
- ▶ High density baffle for low resonance and stable inertial ground.
- ▶ Linear Dynamics Aperture port design minimizes port turbulence and reduces power compression.
- ▶ Reinforced enclosure with standardized mounting points allow mounted installation.

The LSR6312SP powered studio subwoofer is designed to provide low frequency extension and sophisticated bass management capabilities in stereo and multi-channel applications where exceptional spectral accuracy and high-SPL are required. The system includes JBL's RMC™ room mode correction circuit. The system is designed around JBL's 252F LF transducer, which uses dual voice coils and a powerful neodymium magnet. With the patented Neodymium Differential Drive NDD™ technology, power compression is kept to a minimum. An additional third coil located between the two drive coils acts as a dynamic brake to limit excess excursion and reduce audible distortion at the highest operating levels. The cone is made of a carbon fiber



polypropylene composite forming a rigid piston area supported by a soft butyl rubber surround.

A 250-watt continuous power amplifier is integrated into the LSR6312SP system and provides correct drive levels for optimized frequency response. Amplification is class A-B in an all discrete topology.

The subwoofer derives its feed from a combination of Left, Center, Right and Direct LFE inputs. Subwoofer signals can be selectively derived from the front channels or from the Direct input alone using a simple Remote Bypass contact closure switch. User-selectable settings are provided for -10 dBv, +4 and +8 dBu sensitivity. For calibration and level matching of the system, an Input Trim control can be inserted into the circuit for continuously variable attenuation of the system input. Additionally, the Direct input has a dedicated Input Trim. The LSR6312SP includes Left, Center and Right channel outputs to feed external satellite speakers. The LCR outputs are high-passed at 80 Hz. A ¼" jack allows connection of a Remote LCR Bypass contact closure switch. When the switch is used, full-range signals are sent to the Left, Center and Right satellite speakers and the subwoofer derives its feed from the Direct input only.

Subwoofer low pass filtering uses steep 5th order low pass sections to minimize the possibility of localization of the subwoofer's acoustic output. High pass filtering for Left, Center and Right outputs is 12 dB/octave. For convenience, input receptacles are Neutrik "Combi" type, which accommodate both XLR and ¼" connectors.

Six DIP switches on the input panel allow the user to precisely adjust the gain and response of the system. DIP switch one inserts a variable attenuator inserted into the circuit allowing the level to be trimmed from 0 to -13 dB. The Left, Center, Right and Direct inputs default to -10 dBv sensitivity. Using DIP switches 2 & 3 the user can set input sensitivity for all inputs to +4 dBu, +8 dBu or +12 dBu. A signal to any input will drive the output level of the LSR6312SP to 96 dB SPL at 1 meter.

Switch 4 inverts the signal polarity of the subwoofer feed. This is used to correct for placement mismatch between the subwoofer and satellite spacing. Due to the varied placement options available in audio production environments, it is suggested that this switch be adjusted after the final placement of the system has been determined.

# ▶ LSR6312SP Linear Spatial Reference Powered Studio Subwoofer System

Switch 5 adjusts the low frequency spectrum to compensate for the boundary conditions that exist when a subwoofer is placed against a wall or in a corner. Switch 5 reduces the output level below 50 Hz by 2 dB.

Discrete and bypass operation of the subwoofer can be switched via a remote control plugged into a 1/4" jack on the rear of the enclosure. Shorting the ring and tip will remove highpass filtering from the left, center, and right inputs, thus sourcing the subwoofer from the direct input only.

For compatibility with film industry playback standards, a +10 dB LFE sensitivity is provided and engaged by a push-on/push-off switch on the rear electronics panel. This operates only on the Direct input, and its purpose is to restore proper level to the LF effects channel, which may have been previously attenuated by 10 dB during program processing.

## RMC™ Equalization

The LSR6312SP includes JBL's exclusive RMC™ Room Mode Compensation circuitry for final matching of the system response to the room's acoustics. RMC consists of a single parametric cut-only equalizer that is individually tuned to attenuate to the dominant room mode peak in the system's response, thus making the overall room response linear. A kit including a small sound level meter, test CD and a Q template, and a remote bypass switch accompanies each system. Switch 6 defeats the RMC function. The remote bypass switch is connected to the LSR6312SP RMC remote bypass 1/4" jack via a 2-conductor cable.

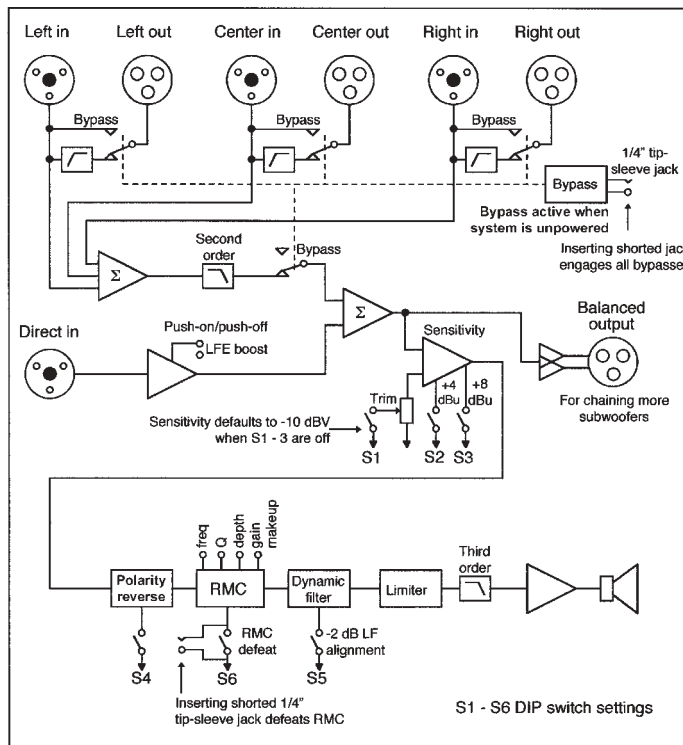
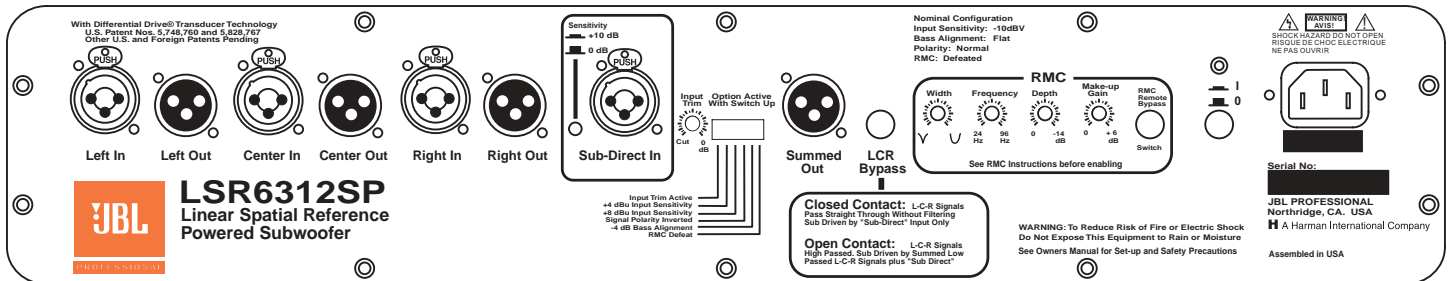

# Specifications:

<b>System:</b>	
Frequency Response (-6 dB):	28 - 80 Hz
Low Frequency Extension:	User controls set to default
-3 dB:	34 Hz
-10 dB:	26 Hz
Enclosure Resonance Frequency:	28 Hz
Low-To-High Crossover Frequency:	80 Hz (4th order electroacoustic Linkwitz-Riley)
Distortion, 96 dB SPL / 1 m:	
Low Frequency (<80 Hz):	
2nd Harmonic:	<2%
3rd Harmonic:	<1%
Maximum Continuous SPL:	>112 dB SPL / 1 m (35 Hz - 80 Hz)
Maximum Peak SPL:	>115 dB SPL / 1 m (35 Hz - 80 Hz)
Calibrated Input Sensitivity:	XLR or ¼"
Selectable -10 dBV, +4 dBu, +8 dBu:	96 dB / 1 m
Power Nonlinearity (20 Hz – 200 Hz):	
30 Watts:	<0.4 dB
100 Watts:	<1.0 dB
Power/Clip/Bypass Indicators:	Green LED – normal operation Amber LED – bypass mode Red LED – Limiter activated
<b>Amplifier:</b>	
Low Frequency Topology:	Class A-B, all discrete
Sine Wave Power Rating:	260 watts (<0.5% THD into rated impedance)
THD + N, ½ Power:	<0.05%
AC Input Voltage:	115 VAC, 60 Hz (230VAC, 50 Hz – model LSR6312SP/230)
AC Input Voltage Operating Range:	±15%
<b>Transducer:</b>	
Low Frequency Model:	252F
Diameter:	300 MM (12 in)
Voice Coil:	50 mm (2 in) Differential Drive <sup>®</sup> with dynamic braking coil
Magnet Type:	Neodymium, with integral heat sink
Cone Type:	Carbon fiber composite
Impedance:	2 ohms
<b>User Controls, Inputs and Outputs:</b>	
Left, Center, Right and Direct Inputs:	Neutrik Combi XLR-¼"
Left, Center and Right Outputs:	Neutrik XLR, balanced (pin 2 hot)
Low Frequency Summed Output:	Neutrik XLR, balanced (pin 2 hot)
Remote Bypass Connector:	¼" tip-sleeve jack
Direct Input LFE +10 dB:	Push-on/push-off switch
LF Output Trim:	0 to -13 dB
LF Sensitivity (+4 dBu):	-10 dBV, +4, +8, +12 dBu
Polarity Reverse:	In/Out
LF Alignment:	0, -2 dB
RMC Defeat:	In/Out
Remote RMC Defeat Connector:	¼" tip-sleeve jack
Subwoofer Bypass Connector:	¼" tip-sleeve jack
RMC Frequency Adjust:	35 Hz - 200 Hz (21 centers)
RMC Depth Adjust:	0 - 14 dB (cut only, 21 steps)
RMC Q Adjust:	1/20th to 1/2 Octave (21 steps)
<b>Physical:</b>	
Finish:	Smooth dark graphite
Enclosure Construction:	19 mm (¾ in) MDF
Mounting:	4 threaded mounting points conforming to industry standard square pattern 127 x 70 mm (5 x 2.75 in) center to center. M6 metric threads.
Baffle Material:	Injection molded structural ABS
Enclosure Volume (net):	50 liter (1.8 cu ft)
Net Weight:	22.7 kg (50 lb)
Dimensions (WxHxD):	63.5 x 39.4 x 29.2 cm (25.0 x 15.5 x 11.5 in)

**Caution:** Unsafe mounting or overhead suspension of any heavy load can result in serious injury and equipment damage. Mounting of speakers should be done by qualified persons in accordance with all applicable local safety and construction standards. Be certain to follow the instructions provided by the manufacturer of the mounting bracket. Before selecting a mounting bracket, be certain that it is capable of supporting the weight of the speaker to be mounted.

## Amplitude & Phase

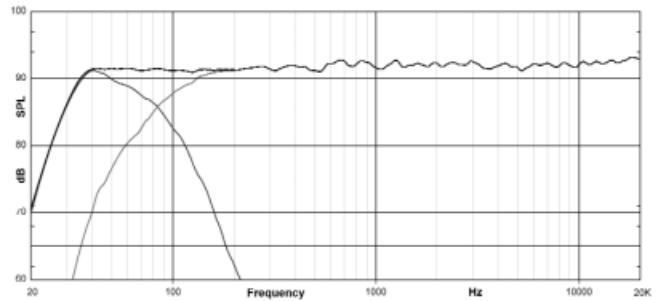

## 96 dB/1 m (Distortion raised 20 dB)

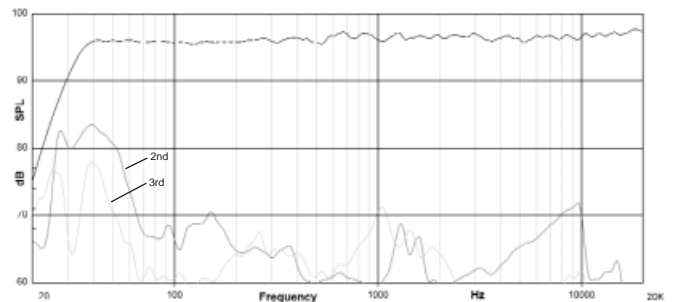

### Notes:

<sup>1</sup> Left, center and right input

<sup>2</sup> Produces quasi-fourth order Linkwitz-Riley acoustic high pass alignment when used with LSR6328P or LSR6332.

All measurements unless otherwise stated made anechoically in a 4π environment at 2 meters and referenced to 1 meter by the inverse square law.

The reference measurement microphone position is located perpendicular to the upper edge of the center of the woofer trim ring.

Acoustic loading provided by the listening room will increase maximum SPL capability and low frequency bass extension as compared to stated anechoic values.

Distortion measurements performed with the input voltage necessary to produce the stated "A" weighted SPL level at the stated measurement distance. Distortion figures refer to the maximum distortion measured in any 1/10th octave wide band in the stated frequency range.

JBL continually engages in research related to produce improvement. New materials, production methods, and design refinements are introduced into existing products without notice as a routine expression of that philosophy. For this reason, any current JBL product may differ in some respect from its published description, but will always equal or exceed the original design specifications unless otherwise stated.

# ▶ LSR6312SP Linear Spatial Reference Powered Studio Subwoofer System

---



JBL Professional  
8500 Balboa Boulevard, P.O. Box 2200  
Northridge, California 91329 U.S.A.

**H** A Harman International Company  
© Copyright 2003 JBL Professional

SS LSR6312P  
CRP 5M  
10/03