



SNAKE EYES™



Blizzard Lighting, LLC
www.blizzardlighting.com
Waukesha, WI USA
Copyright (c) 2016

TABLE OF CONTENTS

Snake Eyes™ Moving Head	1
1. Getting Started	3
What's In The Box?	3
Getting It Out Of The Box	3
Powering Up!	3
Getting A Hold Of Us	3
Safety Instructions (Don't Stick Your Hand In The Toaster!)	4
2. Meet The Snake Eyes™	5
Main Features	5
Additional Features	5
DMX Quick Reference	5
The Snake Eyes™ Pin-up Picture	6
3. Setup	7
Fuse Replacement	7
Connecting A Bunch Of Snake Eyes™ Fixtures	7
Data/DMX Cables	7
Cable Connectors	8
3-Pin??? 5-Pin??? Huh?	8
Take It To The Next Level: Setting up DMX Control	8
Fixture Linking (Master/Slave Mode)	9
Mounting/Rigging	10
Mounting Points	11
Clamp Mounting	11
4. Operating Adjustments	12
The Control Panel	12
Control Panel Menu Structure	13
DMX Mode	14
Select The Channel Mode	14
Select The DMX Starting Address	14
Master/Slave Mode Settings	14
Auto, Stand-Alone, Sound Active Modes	14
Auto Mode	14
Sound Active Mode	14
Manual Test Mode	15
Pan Inverse	15
Fine Pan/Tilt Adjustment	15
Pan Angle Setting	15
No DMX / Lost Signal Setting	15
DMX Channel Values In-Depth	16
Troubleshooting	19
5. Appendix	20
A Quick DMX Lesson	20
Keeping Your Snake Eyes™ As Good As New	21
Returns (Gasp!)	21
Shipping Issues	21
Tech Specs	22
Dimensional Drawings	23

1. GETTING STARTED

What's In The Box?

- 1 x Snake Eyes™ Moving Head Fixture
- An Ever-So-Handy Power Cord
- A Sweet Set of Mounting Brackets
- 1 x Safety Cable
- 1 x DMX Cable
- This Lovely User Manual

Getting It Out Of The Box

Congratulations on purchasing the incredible Snake Eyes™ LED moving head. Your light show is about to get a "wow factor" that can't lose! Now that you've got your Snake Eyes™, you should carefully unpack the box and check the contents to ensure that all parts are present and in good condition. If anything looks as if it has been damaged in transit, notify the shipper immediately and keep the packing material for inspection. Again, please save the carton and all packing materials. If a fixture must be returned to the factory, it is important that the fixture be returned in the original factory box and packing.

Powering Up!

All fixtures must be powered directly off a switched circuit and **cannot be run off a rheostat (variable resistor) or dimmer circuit, even if the rheostat or dimmer channel is used solely for a 0% to 100% switch.**

AC Voltage Switch - Not all fixtures have a voltage select switch, so please verify that the fixture you receive is suitable for your local power supply. See the label on the fixture or refer to the fixture's specifications chart for more information. A fixture's listed current rating is its average current draw under normal conditions. Check the fixture or device carefully to make sure that if a voltage selection switch exists that it is set to the correct line voltage you will use.

Warning! Verify that the voltage select switch on your unit matches the line voltage applied. Damage to your fixture may result if the line voltage applied does not match the voltage indicated on the voltage selector switch. All fixtures must be connected to circuits with a suitable Ground (Earthing).

Getting A Hold Of Us

If something happens goes wrong, please visit www.blizzardlighting.com/support and open a support ticket. We'll be happy to help, honest.

Blizzard Lighting
N24 W23750 Watertown Rd. Suite B
Waukesha, WI 53188 USA
www.blizzardlighting.com

Disclaimer: The information and specifications contained in this document are subject to change without notice. Blizzard Lighting™ assumes no responsibility or liability for any errors or omissions that may appear in this user manual. Blizzard Lighting™ reserves the right to update the existing document or to create a new document to correct any errors or omissions at any time. You can download the latest version of this document from www.blizzardlighting.com.

Author:	Date:	Last Edited:	Date:
J. Thomas	1/1/2016	J. Thomas	1/5/2016

SAFETY INSTRUCTIONS



Please read these instructions carefully. They include important information about the installation, usage and maintenance of this product.

- Please keep this User Guide for future use. If you sell the unit to someone else, be sure that they also receive this User Guide.
- ALWAYS make sure that you are connecting to the proper voltage, and that the line voltage you are connecting to is not higher than that stated on the decal or rear panel of the fixture.
- This product is intended for indoor use only.
- To prevent risk of fire or shock, do not expose fixture to rain or moisture.
- Make sure there are no flammable materials close to the unit while operating.
- The unit must be installed in a location with adequate ventilation, at least 20in (50cm) from adjacent surfaces. Be sure that no ventilation slots are blocked.
- ALWAYS disconnect from the power source before servicing or replacing fuse and be sure to replace with same fuse size and type.
- ALWAYS secure fixture using a safety chain. NEVER carry the fixture by its cord. Use its carrying handles.
- DO NOT operate at ambient temperatures higher than 104°F (40°C).
- In the event of a serious operating problem, stop using the unit immediately. NEVER try to repair the unit by yourself. Repairs carried out by unskilled people can lead to damage or malfunction. Please contact the nearest authorized technical assistance center. Always use the same type spare parts.
- NEVER connect the device to a dimmer pack.
- Make sure the power cord is never crimped or damaged.
- Never disconnect the power cord by pulling or tugging on the cord.
- Avoid direct eye exposure to the light source while it is on.

Caution! There are no user serviceable parts inside the unit. Do not open the housing or attempt any repairs yourself. In the unlikely event your unit may require service, please contact Blizzard Lighting at www.blizzardlighting.com/support.

2. MEET THE SNAKE EYES™ MOVING HEAD

MAIN FEATURES

- 6* 60W OSRAM® RGBW 4-in-1 LEDs, 50,000 hours
- 12* DMX controllable RGB strips
- 630°/540° pan, 360° infinite tilt
- Smooth 3-phase motors
- Automatic pan/tilt position correction
- User selectable 15/37-channel DMX modes
- 1-25Hz strobe
- Built-in auto and sound active programs
- 0-100% linear LED dimmer

ADDITIONAL FEATURES

- Easy-to-use 4-button LCD control panel menu display
- Dual mounting brackets for positioning flexibility
- 3/5-pin male and female DMX In/Out
- PowerCon™ compatible AC power input connector

DMX Quick Reference: 37/15-Channel Mode

Ch.	37-Channel	Ch.	15-Channel
1	Pan	1	Pan
2	Fine Pan	2	Tilt
3	Tilt	3	Infinite tilt
4	Fine Tilt	4	Speed
5	Infinite tilt	5	Red Intensity
6	Speed	6	Green Intensity
7	Red 1 Intensity	7	Blue Intensity
8	Green 1 Intensity	8	White Intensity
9	Blue 1 Intensity	9	Strobe
10	White 1 Intensity	10	Dimmer
11-30	Red/Green/Blue/White, LEDs 2-6	11	LED Strip Auto Program
31	Strobe	12	Auto Modes
32	Dimmer	13	Color Macros
33	LED Strip Auto Program	14	LED Strip Speed
34	Auto Modes	15	Reset
35	Color Macros	--	
36	LED Strip Speed	--	
37	Reset	--	

Figure 1: The Snake Eyes™ Pin-Up Picture

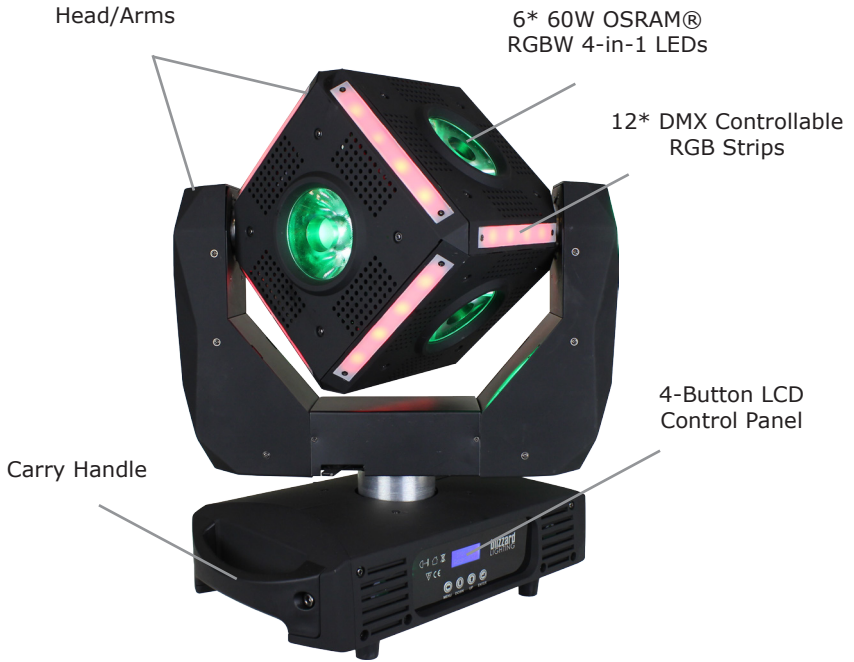
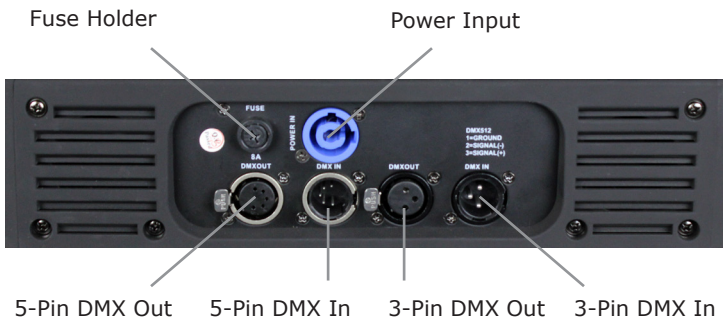

Figure 2: The Rear Connections



3. SETUP



Before replacing a fuse, disconnect power cord. ALWAYS replace with the same type and rating of fuse.

Fuse Replacement

With a phillips head screwdriver, remove the fuse holder from its housing. Remove the damaged fuse from its holder and replace with exact same type fuse. Insert the fuse holder back in its place and reconnect power.

Connecting A Bunch of Snake Eyes™ Fixtures

You will need a serial data link to run light shows using a DMX-512 controller or to run shows on two or more fixtures set to sync in master/slave operating mode. The combined number of channels required by all the fixtures on a serial data link determines the number of fixtures the data link can support.

Fixtures on a serial data link must be daisy chained in one single line. Also, connecting more than 32 fixtures on one serial data link without the use of a DMX optically-isolated splitter may result in deterioration of the digital DMX signal. The maximum recommended cable-run distance is 500 meters (1640 ft). The maximum recommended number of fixtures on a serial data link is 32 fixtures.

Data/DMX Cabling

To link fixtures together you'll need data cables. You should use data-grade cables that can carry a high quality signal and are less prone to electromagnetic interference.

For instance, Belden© 9841 meets the specifications for EIA RS-485 applications. Standard microphone cables will "probably" be OK, but note that they cannot transmit DMX data as reliably over long distances. In any event, the cable should have the following characteristics:

*2-conductor twisted pair plus a shield
Maximum capacitance between conductors – 30 pF/ft.
Maximum capacitance between conductor & shield – 55 pF/ft.
Maximum resistance of 20 ohms / 1000 ft.
Nominal impedance 100 – 140 ohms*

Cable Connectors

Cables must have a male XLR connector on one end and a female XLR connector on the other end. (Duh!)



A Word on Termination: DMX is a resilient communication protocol, however errors still occasionally occur. Termination reduces signal errors, and therefore best practices include use of a terminator in all circumstances. If you are experiencing problems with erratic fixture behavior, especially over long signal cable runs, a terminator may help improve performance.

To build your own DMX Terminator:
Obtain a 120-ohm, 1/4-watt resistor, and wire it between pins 2 & 3 of the last fixture. They are also readily available from specialty retailers.

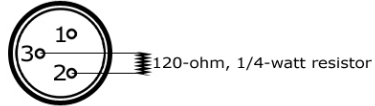

CAUTION: Do not allow contact between the common and the fixture's chassis ground. Grounding the common can cause a ground loop, and your fixture may perform erratically. Test cables with an ohm meter to verify correct polarity and to make sure the pins are not grounded or shorted to the shield or each other.

3-Pin??? 5-Pin??? Huh?!?

If you use a controller with a 5 pin DMX output connector, you will need to use a 5 pin to 3-pin adapter. They are widely available over the internet and from specialty retailers. If you'd like to build your own, the chart below details a proper cable conversion:

Conductor	3-Pin Female (Output)	5-Pin Male (Input)
Ground/Shield	Pin 1	Pin 1
DMX Data (-)	Pin 2	Pin 2
DMX Data (+)	Pin 3	Pin 3
Not Used.	No Connection.	No Connection.
Not Used.	No Connection.	No Connection.

Take It To The Next Level: Setting Up DMX Control

Step 1: Connect the male connector of the DMX cable to the female connector (output) on the controller.



Step 2: Connect the female connector of the DMX cable to the first fixture's male connector (input). *Note:* It doesn't matter which fixture address is the first one connected. We recommend connecting the fixtures in terms of their proximity to the controller, rather than connecting the lowest fixture number first, and so on.

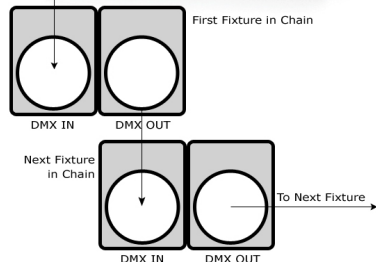

Step 3: Connect other fixtures in the chain from output to input as above. Place a DMX terminator on the output of the final fixture to ensure best communication.

Fixture Linking (Master/Slave Mode)

1. Connect the (male) 3-pin connector side of the DMX cable to the output (female) 3-pin connector of the first fixture.
2. Connect the end of the cable coming from the first fixture which will have a (female) 3-pin connector to the input connector of the next fixture consisting of a (male) 3-pin connector. Then, proceed to connect from the output as stated above to the input of the following fixture and so on.

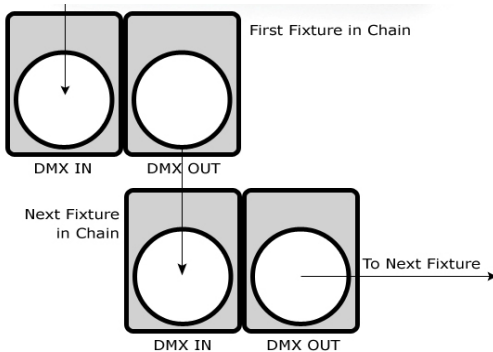

A quick note: Often, the setup for Master-Slave and Standalone operation requires that the first fixture in the chain be initialized for this purpose via either settings in the control panel or DIP-switches. Secondly, the fixtures that follow may also require a slave setting.

Check the **"Operating Adjustments"** section in this manual for complete instructions for this type of setup and configuration.

Mounting & Rigging

This fixture may be mounted in any SAFE position provided there is enough room for ventilation.

It is important never to obstruct the fan or vents pathway. Mount the fixture using a suitable "C" or "O" type clamp. The clamp should be rated to hold at least 10x the fixture's weight to ensure structural stability. Do not mount to surfaces with unknown strength, and ensure properly "rated" rigging is used when mounting fixtures overhead.

Adjust the angle of the fixture by loosening both knobs and tilting the fixture. After finding the desired position, retighten both knobs.

- When selecting installation location, take into consideration lamp replacement access (if applicable) and routine maintenance.
- Safety cables **MUST ALWAYS** be used.
- Never mount in places where the fixture will be exposed to rain, high humidity, extreme temperature changes or restricted ventilation.

Mounting Points

Overhead mounting requires extensive experience, which includes calculating working load limits, knowledge of the installation material being used, and periodic safety inspection of all installation material and the fixture. If you lack these qualifications, do not attempt the installation yourself. Improper installation can result in bodily injury.

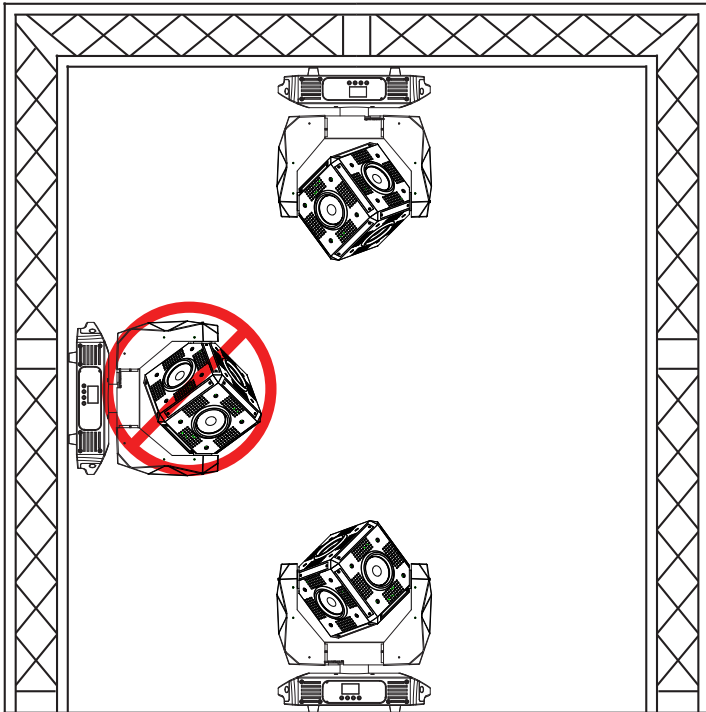

Caution!

Please be aware, you should have a qualified electrician performing all of your electrical connection needs. Better safe than sorry!

Be sure to complete all rigging and installation procedures before connecting the main power cord to the appropriate wall outlet.

Clamp Mounting

This fixture provides a mounting bracket assembly that secures the bottom of the base, the "Omega Bracket," and the safety cable rigging point together. When mounting this fixture to truss, be sure to secure an appropriately rated clamp to the omega bracket using an M10 screw fitted through the center hole of the "omega bracket".

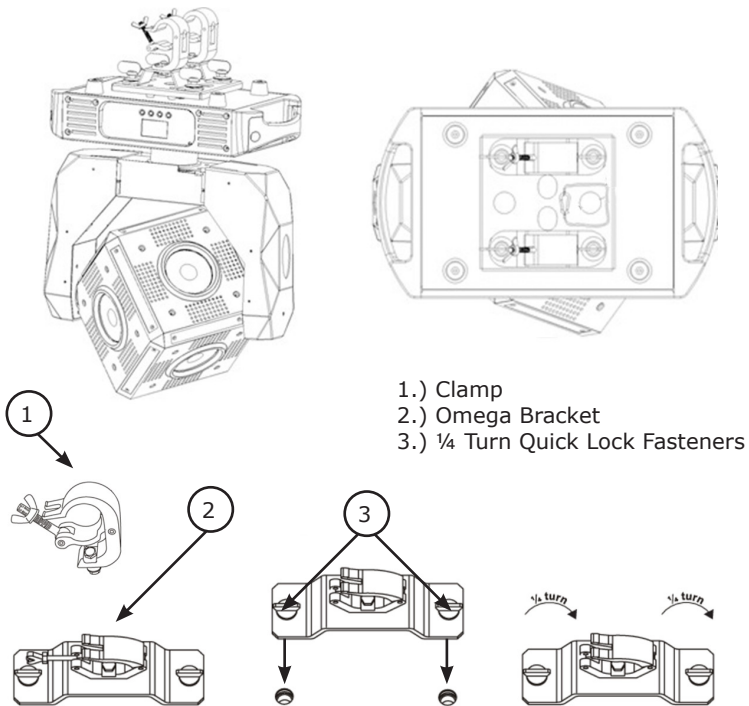

Securing the Fixture

Regardless of the rigging option you choose for your fixtures always be sure to secure your fixture with a safety cable.

4. OPERATING ADJUSTMENTS

The Control Panel

All the goodies and different modes possible with the Snake Eyes™ are accessed by using the control panel on the front of the fixture. There are 4 control buttons below the LCD display which allow you to navigate through the various control panel menus.



Button	Function
<MENU>	Used to access the menu or to return to a previous menu option.
<UP>	Scrolls through menu options in ascending order.
<DOWN>	Scrolls through menu options in descending order.
<ENTER>	Used to select and store the current menu or option within a menu.

Access control panel functions using the four panel buttons located directly underneath the LCD Display.

The control panel LCD display shows the menu items you select from the menu map on page #13. When a menu function is selected, the display will show immediately the first available option for the selected menu function. To select a menu item, press **<ENTER>**.

Use the **<UP>** and **<DOWN>** buttons to navigate the menu map and menu options. Press the **<ENTER>** button to access the menu function currently displayed or to enable a menu option. To return to the previous option or menu without changing the value, press the **<MENU>** button.

Control Panel Menu Structure

DMX Address	001-512	Set the starting address from 001-512
Operate Mode	15 Channel	15-Channel DMX Mode
	37 Channel	37-Channel DMX Mode
	Mast Mode	Master
		Slave
	Auto Mode	Auto 0
		Auto 1
		Auto 2
		Auto 3
		Auto 4
	Sound Control	Mic Sensitivity Level (0 - 99%)
Manual Test	Pan	
	Tilt	
	Individual R/G/B/W Intensity (LEDs 1-6)	
System Setting	Pan Reverse	Yes/No
	Pan Adjust	Fine Pan Adjustment (0-255)
	Tilt Adjust	Fine Tilt Adjustment (0-255)
	Pan Angle Choose	Choose 630°/540° Pan Angle
	Display BkLight	LCD Backlight Continually On (Yes/No)
	Dmx Lost	Blackout
		Hold
		Auto
		Sound
	Encoder	Yes/No (Pan/Tilt Error Correction, On/Off)
	Reset	Reset Motors
Default	Restore Factory Default Settings	
Status Info	Software Version	Current Software Version
	Operate Time	Total Operating Time
	Temp	Working Temperature

DMX Mode

Allows the unit to be controlled by any universal DMX controller.

Select the Channel Mode

- 1.) Press **<MENU>** to enter EDIT interface.
- 2.) Use the **<UP/DOWN>** buttons to choose **Operate Mode**, press **<ENTER>**.
- 3.) Use the **<UP/DOWN>** buttons to highlight **15 Channel** or **37 Channel**.
- 4.) Press the **<ENTER>** to confirm, or **<MENU>** to exit.

Select the Starting DMX Address

- 1.) Press **<MENU>** to enter EDIT interface.
- 2.) Use the **<UP/DOWN>** buttons to choose **DMX Address**, press **<ENTER>**.
- 3.) Use the **<UP/DOWN>** buttons to choose a starting DMX address ranging from 001-512, press **<ENTER>** to confirm, or **<MENU>** to exit.

Master/Slave Mode Settings

- 1.) Connect fixtures together via DMX.
- 2.) Press **<MENU>** to enter EDIT interface.
- 3.) Use the **<UP/DOWN>** buttons to choose **Operate Mode**, press **<ENTER>**.
- 4.) Use the **<UP/DOWN>** buttons to choose **Mast Mode**, press **<ENTER>**.
- 5.) From here you can choose to set each fixture to act as either the master (first in DMX chain), or a slave which will follow the master.
- 6.) Press **<ENTER>** to confirm your choice.

Auto and Sound Active Modes:

***Important:** To use Auto or Sound Active modes in **Standalone**, the settings in **DMX Lost** must also be set to match: **Auto** or **Sound Active**. Press **<MENU>**, go to **<System Settings>**, navigate to **<DMX Lost>**, select **<Auto>** or **<Sound>** and save. Then...

Auto Mode

- 1.) Press **<MENU>** to enter EDIT interface.
- 2.) Use the **<UP/DOWN>** buttons to choose **Operate Mode**, press **<ENTER>**.
- 3.) Use the **<UP/DOWN>** buttons to choose **Auto Mode**, press **<ENTER>**.
- 4.) Use the **<UP/DOWN>** buttons to choose a built-in program, press **<ENTER>**.

Sound Active Mode

- 1.) Press **<MENU>** to enter EDIT interface.
- 2.) Use the **<UP/DOWN>** buttons to choose **Operate Mode**, press **<ENTER>**.
- 3.) Use the **<UP/DOWN>** buttons to choose **Sound Control**, press **<ENTER>**.
- 4.) Use the **<UP/DOWN>** buttons to choose the microphone sensitivity level ranging from 0% to 99%, press **<ENTER>**.

Manual Test Mode

These are used to test the functionality of each, not to globally set each function.

- 1.) Press **<MENU>** to enter EDIT interface.
- 2.) Use the **<UP/DOWN>** buttons to choose **Operate Mode**, press **<ENTER>**.
- 3.) Use the **<UP/DOWN>** buttons to choose **Manual Control**, press **<ENTER>**.
- 4.) Use the **<UP/DOWN>** buttons to highlight either **<PAN>**, **<TILT>**, **<Red1>**, **<Green1>**, **<Blue1>**, **<White1>**, **<Red2>**, **<Green2>**, **<Blue2>**, **<White2>**, **<Red3>**, **<Green3>**, **<Blue3>**, **<White3>**, **<Red4>**, **<Green4>**, **<Blue4>**, **<White4>**, **<Red5>**, **<Green5>**, **<Blue5>**, **<White5>**, **<Red6>**, **<Green6>**, **<Blue6>**, or **<White6>**, and press **<ENTER>**.
- 5.) Press **<UP/DOWN>** buttons to choose a value ranging from 000-255.
- 6.) Press **<ENTER>** to confirm.

Pan Inverse

- 1.) Press **<MENU>** to enter EDIT interface.
- 2.) Use the **<UP/DOWN>** buttons to choose **System Settings**, press **<ENTER>**.
- 3.) Use the **<UP/DOWN>** buttons to choose **Pan Inverse**, press **<ENTER>**.
- 4.) Use the **<UP/DOWN>** buttons to choose **Yes/No**, press **<ENTER>** to confirm, or **<MENU>** to exit.

Fine Pan/Tilt Adjustment

- 1.) Press **<MENU>** to enter EDIT interface.
- 2.) Use the **<UP/DOWN>** buttons to choose **System Settings**, press **<ENTER>**.
- 3.) Use the **<UP/DOWN>** buttons to choose **Pan Adjust** or **Tilt Adjust**, press **<ENTER>**.
- 4.) Use the **<UP/DOWN>** buttons to choose a value ranging from 000-255, press **<ENTER>** to confirm, or **<MENU>** to exit.

Pan Angle Setting

- 1.) Press **<MENU>** to enter EDIT interface.
- 2.) Use the **<UP/DOWN>** buttons to choose **System Settings**, press **<ENTER>**.
- 3.) Use the **<UP/DOWN>** buttons to choose **Pan Angle Choose**, press **<ENTER>**.
- 4.) Use the **<UP/DOWN>** buttons to choose either **630°** or **540°**, press **<ENTER>** to confirm, or **<MENU>** to exit.

No DMX / Lost Signal Setting

- 1.) Press **<MENU>** to enter EDIT interface.
- 2.) Use the **<UP/DOWN>** buttons to choose **System Settings**, press **<ENTER>**.
- 3.) Use the **<UP/DOWN>** buttons to choose **DMX Lost**, press **<ENTER>**.
- 4.) Use the **<UP/DOWN>** buttons to choose either **Hold** (holds the current status), **Blackout** (no light output), **Sound** (run sound mode), or **Auto** (run auto programs), then press **<ENTER>** to confirm, or **<MENU>** to exit.

DMX Values In-Depth (37-Channel Mode)

Channel	Value	What It Does
1	000 <--> 255	Pan
2	000 <--> 255	Pan Fine
3	000 <--> 255	Tilt
4	000 <--> 255	Tilt Fine
5	000 <--> 030 031 <--> 140 141 <--> 145 146 <--> 255	Infinite Tilt Stop Counterclockwise (fast <--> slow) Stop Clockwise (slow <--> fast)
6	000 <--> 225 226 <--> 255	Speed Speed (fast <--> slow) Maximum speed
7	000 <--> 255	LED 1 - Red Intensity (0% <--> 100%)
8	000 <--> 255	LED 1 - Green Intensity (0% <--> 100%)
9	000 <--> 255	LED 1 - Blue Intensity (0% <--> 100%)
10	000 <--> 255	LED 1 - White Intensity (0% <--> 100%)
11	000 <--> 255	LED 2 - Red Intensity (0% <--> 100%)
12	000 <--> 255	LED 2 - Green Intensity (0% <--> 100%)
13	000 <--> 255	LED 2 - Blue Intensity (0% <--> 100%)
14	000 <--> 255	LED 2 - White Intensity (0% <--> 100%)
15	000 <--> 255	LED 3 - Red Intensity (0% <--> 100%)
16	000 <--> 255	LED 3 - Green Intensity (0% <--> 100%)
17	000 <--> 255	LED 3 - Blue Intensity (0% <--> 100%)
18	000 <--> 255	LED 3 - White Intensity (0% <--> 100%)
19	000 <--> 255	LED 4 - Red Intensity (0% <--> 100%)
20	000 <--> 255	LED 4 - Green Intensity (0% <--> 100%)
21	000 <--> 255	LED 4 - Blue Intensity (0% <--> 100%)
22	000 <--> 255	LED 4 - White Intensity (0% <--> 100%)
23	000 <--> 255	LED 5 - Red Intensity (0% <--> 100%)
24	000 <--> 255	LED 5 - Green Intensity (0% <--> 100%)
25	000 <--> 255	LED 5 - Blue Intensity (0% <--> 100%)
26	000 <--> 255	LED 5 - White Intensity (0% <--> 100%)
27	000 <--> 255	LED 6 - Red Intensity (0% <--> 100%)
28	000 <--> 255	LED 6 - Green Intensity (0% <--> 100%)
29	000 <--> 255	LED 6 - Blue Intensity (0% <--> 100%)
30	000 <--> 255	LED 6 - White Intensity (0% <--> 100%)
31	000 <--> 015 016 <--> 095 096 <--> 169 170 <--> 175 176 <--> 255	Strobe No Function Strobe, 1Hz-25Hz (slow <--> fast) Strobe (fast <--> slow) Strobe (slow <--> fast) Random Strobe (slow <--> fast)
32	000 <--> 255	Dimmer

DMX Values In-Depth (37-Channel Mode), Continued

Channel	Value	What It Does
33	000 <--> 036	LED Strip Auto Programs
	037 <--> 056	No Function
	057 <--> 077	Red
	078 <--> 098	Green
	099 <--> 119	Blue
	120 <--> 140	Yellow
	141 <--> 161	Magenta
	162 <--> 176	Cyan
	177 <--> 186	White
	187 <--> 196	Multicolor Fading
	197 <--> 206	Red Chase
	207 <--> 216	Green Chase
	217 <--> 226	Blue Chase
	227 <--> 236	Yellow Chase
	237 <--> 246	Magenta Chase
247 <--> 255	Cyan Chase	
34	000 <--> 015	Auto Programs
	016 <--> 063	No Function
	064 <--> 111	Auto 0
	112 <--> 159	Auto 1
	160 <--> 207	Auto 2
	208 <--> 255	Auto 3
		Auto 4
35	000 <--> 045	Color Macros
	046 <--> 065	No Function
	066 <--> 085	Red
	086 <--> 105	Green
	106 <--> 125	Blue
	126 <--> 145	White
	146 <--> 165	Yellow
	166 <--> 185	Magenta
	186 <--> 205	Cyan
	206 <--> 255	White
		Multicolor Fading (fast <--> slow)
36	000 <--> 255	LED Strip Speed (slow <--> fast)
37	000 <--> 030	Reset
	031 <--> 049	No Function
	050 <--> 255	Reset
		No Function

DMX Values In-Depth (15-Channel Mode)

Channel	Value	What It Does
1	000 <--> 255	Pan
2	000 <--> 255	Tilt
3	000 <--> 030	Infinite Tilt
	031 <--> 140	Stop
	141 <--> 145	Counterclockwise (fast <--> slow)
	146 <--> 255	Stop
4	000 <--> 225	Speed
	226 <--> 255	Speed (fast <--> slow)
		Maximum speed

DMX Values In-Depth (15-Channel Mode), Continued

Channel	Value	What It Does
5	000 <--> 255	Red Intensity (0% <--> 100%)
6	000 <--> 255	Green Intensity (0% <--> 100%)
7	000 <--> 255	Blue Intensity (0% <--> 100%)
8	000 <--> 255	White Intensity (0% <--> 100%)
9	000 <--> 015 016 <--> 095 096 <--> 169 170 <--> 175 176 <--> 255	Strobe No Function Strobe, 1Hz-25Hz (slow <--> fast) Strobe (fast <--> slow) Strobe (slow <--> fast) Random Strobe (slow <--> fast)
10	000 <--> 255	Dimmer
11	000 <--> 036 037 <--> 056 057 <--> 077 078 <--> 098 099 <--> 119 120 <--> 140 141 <--> 161 162 <--> 176 177 <--> 186 187 <--> 196 197 <--> 206 207 <--> 216 217 <--> 226 227 <--> 236 237 <--> 246 247 <--> 255	LED Strip Auto Programs No Function Red Green Blue Yellow Magenta Cyan White Multicolor Fading Red Chase Green Chase Blue Chase Yellow Chase Magenta Chase Cyan Chase White Chase
12	000 <--> 015 016 <--> 063 064 <--> 111 112 <--> 159 160 <--> 207 208 <--> 255	Auto Programs No Function Auto 0 Auto 1 Auto 2 Auto 3 Auto 4
13	000 <--> 045 046 <--> 065 066 <--> 085 086 <--> 105 106 <--> 125 126 <--> 145 146 <--> 165 166 <--> 185 186 <--> 205 206 <--> 255	Color Macros No Function Red Green Blue White Yellow Magenta Cyan White Multicolor Fading (fast <--> slow)
14	000 <--> 255	LED Strip Speed (slow <--> fast)
15	000 <--> 030 031 <--> 049 050 <--> 255	Reset No Function Reset No Function

Troubleshooting

Symptom	Solution
Fixture Auto-Shut Off	Check the fan in the fixture. If it is stopped or moving slower than normal, the unit may have shut itself off due to high heat. This is to protect the fixture from overheating. Clear the fan of obstructions, or return the unit for service.
Beam is Dim	Check optical system and clean excess dust/grime.
No Light Output	Check to ensure fixture is operating under correct mode, IE sound active/auto/DMX/Etc., if applicable.
Chase Speed Too Fast/Slow	Check to ensure proper setup of speed adjustment.
No Power	Check fuse, AC cord and circuit for malfunction.
Blown Fuse	Check AC cord and circuit for damage, verify that moving parts are not restricted and that unit's ventilation is not obstructed
No Response to Audio	Verify that the fixture is in "Sound Active" mode.
Fixture Not Responding / Responding Erratically	Make sure all connectors are seated properly and securely. Use Only DMX Cables and/or check cables for defects Install a Terminator. Reset fixture(s).

If your problem persists or isn't listed, visit www.blizzardlighting.com/support.

5. APPENDIX

A Quick Lesson On DMX

DMX (aka DMX-512) was created in 1986 by the United States Institute for Theatre Technology (USITT) as a standardized method for connecting lighting consoles to lighting dimmer modules. It was revised in 1990 and again in 2000 to allow more flexibility. The Entertainment Services and Technology Association (ESTA) has since assumed control over the DMX512 standard. It has also been approved and recognized for ANSI standard classification.

DMX covers (and is an abbreviation for) Digital MultipleXed signals. It is the most common communications standard used by lighting and related stage equipment.

DMX provides up to 512 control "channels" per data link. Each of these channels was originally intended to control lamp dimmer levels. You can think of it as 512 faders on a lighting console, connected to 512 light bulbs. Each slider's position is sent over the data link as an 8-bit number having a value between 0 and 255. The value 0 corresponds to the light bulb being completely off while 255 corresponds to the light bulb being fully on.

DMX data is transmitted at 250,000 bits per second using the RS-485 transmission standard over two wires. As with microphone cables, a grounded cable shield is used to prevent interference with other signals.

There are five pins on a DMX connector: a wire for ground (cable shield), two wires for "Primary" communication which goes from a DMX source to a DMX receiver, and two wires for a "Secondary" communication which goes from a DMX receiver back to a DMX source. Generally, the "Secondary" channel is not used so data flows only from sources to receivers. Hence, most of us are most familiar with DMX-512 as being employer over typical 3-pin "mic cables," although this does not conform to the defined standard.

DMX is connected using a daisy-chain configuration where the source connects to the input of the first device, the output of the first device connects to the input of the next device, and so on. The standard allows for up to 32 devices on a single DMX link.

Each receiving device typically has a means for setting the "starting channel number" that it will respond to. For example, if two 6-channel fixtures are used, the first fixture might be set to start at channel 1 so it would respond to DMX channels 1 through 6, and the next fixture would be set to start at channel 7 so it would respond to channels 7 through 12.

The greatest strength of the DMX communications protocol is that it is very simple and robust. It involves transmitting a reset condition (indicating the start of a new "packet"), a start code, and up to 512 bytes of data. Data packets are transmitted continuously. As soon as one packet is finished, another can begin with no delay if desired (usually another follows within 1 ms). If nothing is changing (i.e. no lamp levels change) the same data will be sent out over and over again. This is a great feature of DMX -- if for some reason the data is not interpreted the first time around, it will be re-sent shortly.

Not all 512 channels need to be output per packet, and in fact, it is very uncommon to find all 512 used. The fewer channels are used, the higher the "refresh" rate. It is possible to get DMX refreshes at around 1000 times per second if only 24 channels are being transmitted. If all 512 channels are being transmitted, the refresh rate is around 44 times per second.

In summary, since its design and evolution in the 1980's DMX has become the standard for lighting control. It is flexible, robust, and scalable, and its ability to control everything from dimmer packs to moving lights to foggers to lasers makes it an indispensable tool for any lighting designer or lighting performer.

Keeping Your Snake Eyes™ As Good As New

The fixture you've received is a rugged, tough piece of pro lighting equipment, and as long as you take care of it, it will take care of you. That said, like anything, you'll need to take care of it if you want it to operate as designed. You should absolutely keep the fixture clean, especially if you are using it in an environment with a lot of dust, fog, haze, wild animals, wild teenagers or spilled drinks.

Cleaning the optics routinely with a suitable glass cleaner will greatly improve the quality of light output. Keeping the fans free of dust and debris will keep the fixture running cool and prevent damage from overheating.

In transit, keep the fixtures in cases. You wouldn't throw a prized guitar, drumset, or other piece of expensive gear into a gear trailer without a case, and similarly, you shouldn't even think about doing it with your shiny new light fixtures.

Common sense and taking care of your fixtures will be the single biggest thing you can do to keep them running at peak performance and let you worry about designing a great light show, putting on a great concert, or maximizing your client's satisfaction and "wow factor." That's what it's all about, after all!

Returns (Gasp!)

We've taken a lot of precautions to make sure you never even have to worry about sending a defective unit back, or sending a unit in for service. But, like any complex piece of equipment designed and built by humans, once in a while, something doesn't go as planned. If you find yourself with a fixture that isn't behaving like a good little fixture should, you'll need to obtain a Return Authorization (RA).

Don't worry, this is easy. Just visit www.blizzardlighting.com/support and open a support ticket, and we'll issue you an RA. Then, you'll need to send the unit to us using a trackable, pre-paid freight method. We suggest using USPS Priority or UPS. Make sure you carefully pack the fixture for transit, and whenever possible, use the original box & packing for shipping.

When returning your fixture for service, be sure to include the following:

- 1.) Your contact information (Name, Address, Phone Number, Email address).
- 2.) The RA# issued to you
- 3.) A brief description of the problem/symptoms.

We will, at our discretion, repair or replace the fixture. Please remember that any shipping damage which occurs in transit to us is the customer's responsibility, so pack it well!

Shipping Issues

Damage incurred in shipping is the responsibility of the shipper, and must be reported to the carrier immediately upon receipt of the items. Claims must be made within seven (7) days of receipt.

Tech Specs!

Weight & Dimensions	
Width	16 inches (407 mm)
Depth	12.2 inches (309.1 mm)
Height	19.2 in. (486 mm)
Weight	32 lbs (14.5 kg)
Power	
Operating Voltage	100-240VAC, 50-60Hz
Power Consumption	680W, 5.95A, PF:.98
Light Source	
LED	6* 60W OSRAM® RGBW 4-in-1 LEDs 12* DMX Controllable RGB Strips
Optical	
Beam Angle	4° beam angle
Luminous Intensity	37,434 Lux @ 2m 7,306 Lux @ 5m (x6)
Thermal	
Max. Operating Temp.	104 degrees F (40 degrees C) ambient
Control	
Protocol	USITT DMX-512
DMX Channels	15/37-channel DMX
Input	3/5-pin XLR Male
Output	3/5-pin XLR Female
Other Operating Modes	Standalone, Master/Slave, Sound Active, Color Preset
Other Information	
Enjoy your Snake Eyes. You won't be diceappointed!	
Warranty	
2-year limited warranty, does not cover malfunction caused by damage to LEDs.	

DISCLAIMER:

The power connector fitted to the fixture and fixture cord are designed for compatibility with products manufactured by Neutrik AG, Neutrik USA and their related entities, however they are not manufactured by, affiliated with or endorsed by Neutrik AG, Neutrik USA, or any related entity. Neutrik® and powerCON® are registered trademarks of Neutrik AG.

Dimensional Drawings

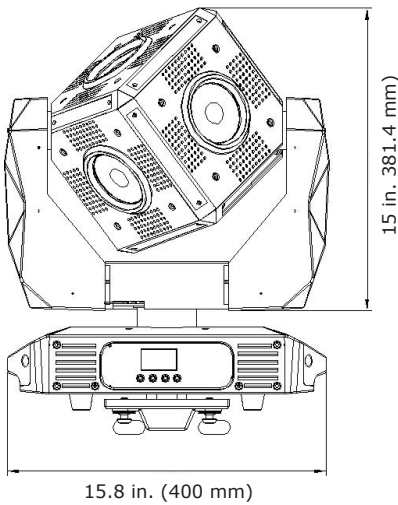
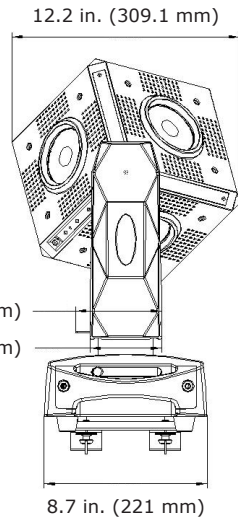
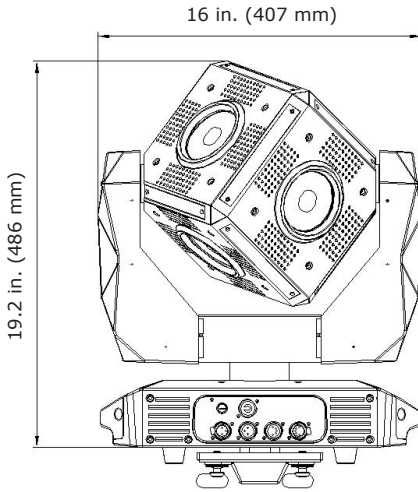



**Enjoy your product!
Our sincerest thanks for your purchase!
--The team @ Blizzard Lighting**