



VADDIO™ POWERVIEW™ HD-22 QCCU AND HD-30 QCCU SYSTEMS

Featuring the Quick-Connect Universal CCU

PowerVIEW HD-22 QCCU Systems

Part Numbers:

999-6967-000: North America

999-6967-001: International

PowerVIEW HD-30 QCCU Systems

Part Numbers:

999-6977-000: North America

999-6977-001: International



Universal CCU for HD-22 or HD-30 (shown without Rack Ears)

EZIM™ Slot Card Interface
Part Number: 998-6700-006



Inside Front Cover - Blank



Table of Contents

- Overview..... 4
 - Intended Use..... 4
 - Important Safeguards 4
 - Save These Instructions 4
- Unpacking..... 5
 - PowerVIEW HD-22 QCCU 5
 - PowerVIEW HD-30 QCCU 5
- Anatomy of the HD-22 and HD-30..... 6
 - Image: PowerVIEW HD-22/30 HD PTZ Camera..... 6
 - Image: PowerVIEW HD-20 or HD-30 HD PTZ Camera (Rear Panel) 7
- First Time Set-up with the PowerVIEW HD-22 or HD-30: 8
 - Image: PowerVIEW HD-22/30 Rear Panel Connections 8
 - Drawing: Dip Switch and Resolution Label on the Bottom of the HD-22/30 8
- Anatomy of the Quick-Connect Universal CCU..... 9
 - Image: Quick-Connect Universal CCU HD-22/30 Front Panel Controls 9
 - Image: Close up View of the Universal CCU HD-22/30 Control Panel 9
 - Image: Rear Panel CCU Connections and Controls (left to right)..... 10
 - The EZIM (EZ Interface Module) HD-Series Slot Card..... 10
 - Image: EZIM Slot Card 10
- The HD-22 and HD-30 Control Menu Screens..... 11
 - Image: Menu Organization HD-22/30 11
- Installation Basics:..... 13
 - General Installation Instructions for the CONCEAL Wall Mounting System:..... 13
 - Drawing: Basic System Connectivity 15
- Optimizing System Performance: 16
- General Specifications:..... 17
- Warranty Information: 18
- Compliance and CE Declaration of Conformity - PowerVIEW HD-22 and HD30 19
- Compliance and CE Declaration of Conformity - Universal CCU and EZIM CCU 20
- Appendix 1: Cable Pin-outs for the Quick-Connect CCU System..... 21
 - Table: New Commands for the CCU Scene Selection 22
- Appendix 2: PowerVIEW EZ-Power Video RJ-45 Connector Pin-outs 23
 - Drawing: PowerVIEW HD-22/30 Dimensions 23
- Appendix 3: Communication Specification 24
 - HD-22/30 Command List (1/2) 24
 - HD-22/30 Command List (2/2) 25
 - HD-22/30 Inquiry List (1/1) 26

Overview



PowerVIEW
HD-22 or HD-30

The WallVIEW Universal CCU system for the PowerVIEW HD-22 and PowerVIEW HD-30 HD Pan/Tilt/Zoom Camera Systems includes the HD-22 or HD-30 PTZ camera, the Quick-Connect™ Universal CCU, matching CONCEAL™ camera mount, EZIM CCU Slot Card and accessories (mounting hardware, control adapter).

The Vaddio PowerVIEW HD-22 and HD-30 high definition PTZ cameras are available with 22X and 30X power zoom optics respectively. With a 1/2.8-Type, progressive scan 1MOS image sensor, the cameras allow for better light sensitivity, increased noise reduction and lower power consumption. This advanced MOS image sensor provides for delicate gradation, realistic textures and vivid colors that are comparable to 3-chip camera performance.

The HD-22 has a powerful 22X multi-element glass zoom lens ($f=4.3\text{mm}$ to 94.6mm) and works exceptionally in large rooms. However, the premium optics also provides a wide horizontal field of view of 65.2° , which works very well in small room video applications. The HD-30, as the name would suggest, has a robust 30X optical power zoom lens that enables the capture of brilliant and detailed video images even in the largest rooms. The cameras output multi-format HD video in both analog component (YPbPr), HDMI and differential formats in HD resolutions of 1080p/59.94, 1080p/50 1080p/29.97 1080p/25, 1080i/59.94, 1080i/50, 720p/59.94, 720p/50 and SD resolutions of 480p/59.97 and 576p/50.

These systems pair the Quick-Connect Universal CCU with the HD-22/30. The Universal CCU Cat-5 uses HSDS™ (high speed differential signaling), an active video transmission system, to deliver high quality HD video over standard Cat-5 cabling up to 500' (152.4m) with virtually no loss in video quality and no latency. One of the most flexible attributes the Universal CCU is at the outputs. It has HD-SDI or SDI outputs (yep, even 3 Gb/s single link HD-SDI for 1080p/59.94), HDMI and HD Analog component (YPbPr) outputs, all of which can be used concurrently (at the same resolution). Available resolutions range from 480i up to and including 1080p/59.94 on all outputs. The Universal CCU has an attractive industrial design that also simplifies the operation of the CCU. The back-lit blue LED screen displays up to eight (8) parameters at a time, as well as the camera's model number so the interrelationship of the controls is easily and quickly read and understood.

The Universal CCU series for PowerVIEW HD-22 and HD-30 allows the user to adjust auto AWB or Manual Red and Blue Gain, OPWB, Iris functions, Gain, Chroma, Pedestal, Detail, and Gamma on the cameras. These controls allow the camera to deliver a more accurate representation of the captured image's color. Other added advantages include the ability to color match multiple cameras and eliminate the need to use automatic exposure and color settings.

Overall, any WallVIEW System using the Quick-Connect Universal CCU is superb for a wide range of serious, high definition shooting applications. It is also great where adjusting the color and brightness levels of one or multiple cameras is critical, as in houses of worship, corporate boardrooms, live event production and distance-learning applications.

Intended Use

Before operating the device, please read the entire manual thoroughly. The system was designed, built and tested for use indoors, and with the provided power supply and cabling. The use of a power supply other than the one provided or outdoor operation has not been tested and could damage the device and/or create a potentially unsafe operating condition.

Important Safeguards

Read and understand all instructions before using. Do not operate any device if it has been dropped or damaged. In this case, a Vaddio technician must examine the product before operating. To reduce the risk of electric shock, do not immerse in water or other liquids and avoid extremely humid conditions. Do not connect Power over Ethernet (PoE) cables directly to the RJ-45 ports on the device as damage may result.



Use only the power supply provided with the system. Use of any unauthorized power supply will void any and all warranties.

Please do not use "pass-thru" type RJ-45 connectors. These pass-thru type connectors do not work well for professional installations and can be the cause of intermittent connections which can result in the RS-232 control line failing and locking up. For best results please use standard RJ-45 connectors and test all cables for proper pin-outs prior to use. Mark all cables to avoid errant connections.

Save These Instructions

The information contained in this manual will help you install and operate the product. If these instructions are misplaced, Vaddio keeps copies of Specifications, Installation & User Guides and most *pertinent* product drawings for the Vaddio product line on the Vaddio website.

Unpacking

Carefully remove the device and all of the parts from the packaging. Unpack and identify the following parts:

PowerVIEW HD-22 QCCU

Part Number: 999-6967-000, North America

- One (1) Vaddio PowerVIEW HD-22PTZ Camera (998-6960-000)
- One (1) Universal CCU Cat-5 for HD-22 or HD-30 with Rack Ears
- One (1) 36 VDC Switching power supply with power cord for North America
- One(1) 2-pin Phoenix-type 5.0mm Euro style connector (for Tally LED)
- One (1) EZIM CCU Slot Card
- One (1) CONCEAL Mount with hardware kit
- One (1) 998-1001-232, 9-Pin D-Sub-F to RJ-45F EZCamera Control Adapter
- Quick Start Guide

Full Manuals are downloaded from support.vaddio.com

Part Number: 999-6967-001 International

- One (1) Vaddio PowerVIEW HD-22PTZ Camera (998-6960-000)
- One (1) Universal CCU Cat-5 for HD-22 or HD-30 with Rack Ears
- One (1) 36 VDC, 2.78 Amp Switching power supply
- One (1) Euro Power Cord
- One (1) UK Power Cord
- One(1) 2-pin Phoenix-type 5.0mm Euro style connector (for Tally LED)
- One (1) EZIM CCU Slot Card
- One (1) CONCEAL Mount with hardware kit
- One (1) 998-1001-232, 9-Pin D-Sub-F to RJ-45F EZCamera Control Adapter
- Quick Start Guide

Full Manuals are downloaded from support.vaddio.com

PowerVIEW HD-30 QCCU

Part Number: 999-6977-000, North America

- One (1) Vaddio PowerVIEW HD-30 HD PTZ Camera (998-6970-000)
- One (1) Universal CCU Cat-5 for HD-22 or HD-30 with Rack Ears
- One (1) 36 VDC Switching power supply with power cord for North America
- One(1) 2-pin Phoenix-type 5.0mm Euro style connector (for Tally LED)
- One (1) EZIM CCU Slot Card
- One (1) CONCEAL Mount with hardware kit
- One (1) 998-1001-232, 9-Pin D-Sub-F to RJ-45F EZCamera Control Adapter
- Quick Start Guide

Full Manuals are downloaded from support.vaddio.com

Part Number: 999-6977-001 International

- One (1) Vaddio PowerVIEW HD-30 HD PTZ Camera (998-6970-000)
- One (1) Universal CCU Cat-5 for HD-22 or HD-30 with Rack Ears
- One (1) 36 VDC, 2.78 Amp Switching power supply
- One (1) Euro Power Cord
- One (1) UK Power Cord
- One(1) 2-pin Phoenix-type 5.0mm Euro style connector (for Tally LED)
- One (1) EZIM CCU Slot Card
- One (1) CONCEAL Mount with hardware kit
- One (1) 998-1001-232, 9-Pin D-Sub-F to RJ-45F EZCamera Control Adapter
- Quick Start Guide

Full Manuals are downloaded from support.vaddio.com



CONCEAL Mount includes:

- Metal Bracket,
- Bottom Cover
- Rear Connector/Cable Cover
- Mounting Hardware

Anatomy of the HD-22 and HD-30

Image: PowerVIEW HD-22/30 HD PTZ Camera

Front View with Feature Call-outs:



1) Camera and Zoom Lens:

The 22X (HD-22) or 30X (HD-30) optical zoom lens is built around a (1/2.8 Type) high-speed MOS image sensor with a total of 2.2 megapixels for precise HD video image acquisition.

2) Red Tally Light:

A red tally light is illuminated when the camera receives a command from an external control system.

3) IR Sensors:

IR sensors are built into the front of the PowerVIEW HD-22/30 to receive IR signals from the IR remote control supplied with the camera.

4) Blue Power Light:

A Vaddio blue power light is illuminated when the camera is turned on.

Image: PowerVIEW HD-20 or HD-30 HD PTZ Camera (Rear Panel)
 Rear Panel Connections with Feature Call-outs

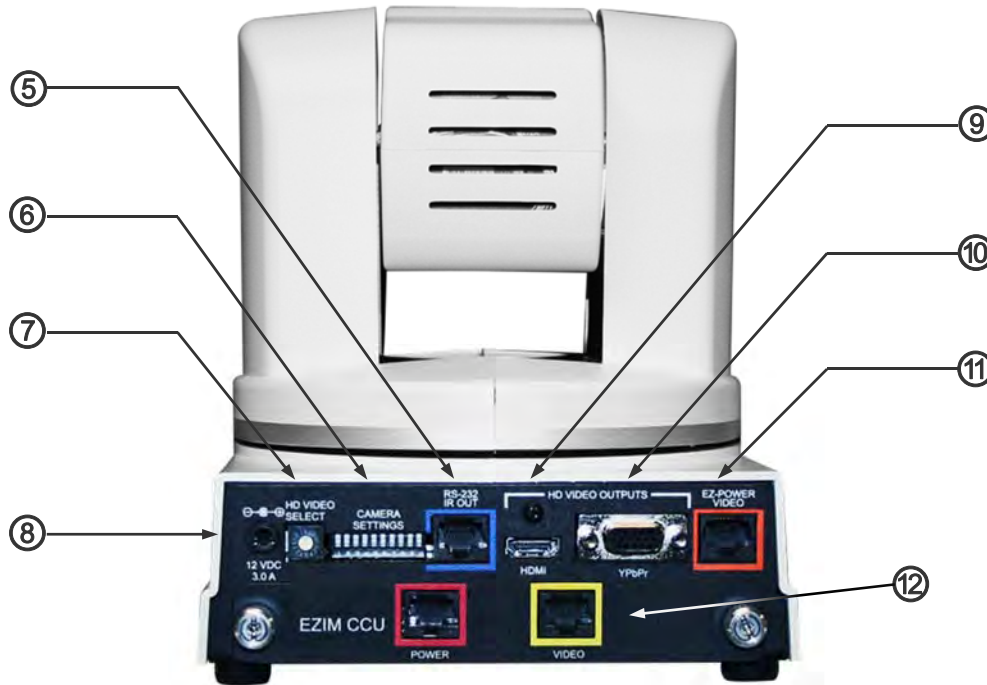

5) RS-232 & IR Out Port (Color Coded Blue):

The RS-232 accepts modified VISCA protocol for camera control, however the IR Forwarding is not supported by the Quick-Connect Universal CCU.

6) Dip Switch Settings:

Settings for IR remote, baud rate and image flip can be configured on these switches. See the Switch Settings page for additional information.

7) HD Video Select:

A rotary switch allows the user to choose the component HD output video resolution and format. See the Switch Settings page for additional information.

- **HD Resolution Note:** When changing the resolution of the camera, the camera may need to be power-cycled. If changing the resolution on any camera while plugged into even the most sophisticated switcher, the switcher may need to be reset or rebooted.

8) 12 VDC Input:

Power input for the standard, PowerVIEW HD-22 and HD-30 camera power supply.

9) HDMI Output:

The HDMI output feeds out HD digital video only (no copy protect or device communication is included). The HDMI output is optimized for HD video signals (seems logical).

10) YPbPr Output:

Component HD video (YPbPr) is output through the DE-15 connector. YPbPr and HDMI signals are simultaneous. Limited SD resolutions are supported.

11) EZ-POWER VIDEO Port (Color Coded Orange): This RJ-45 connector is only used with the Quick-Connect SR Interface, Quick-Connect DVI-D/HDMI SR Interface and the Quick-Connect USB Interface to supply power and return HSDS (differential) video from the camera. This port is not used with the QCCU Systems.

12) Slot for Optional Cards:

The EZIM CCU slot card for the CCU can be plugged into the PowerVIEW HD-22 HD camera.

First Time Set-up with the PowerVIEW HD-22 or HD-30:

The PowerVIEW HD-22 and HD-30 were designed to be very easy to use and operate. There is documentation at the back of this manual for pin-outs of the connectors on the PowerVIEW HD-22 camera.

Step 1: Using the HD VIDEO SELECT rotary switch and CAMERA SETTINGS dip switches on the back of the camera, set up the camera's output resolution and functional preferences. There is a label on the bottom of the camera that identifies the choices.

Important Dip Switch Note: Setting all dip switches down and power cycling the camera will load the factory default camera settings. For the first time set-up, loading the defaults may be a good idea.

Image: PowerVIEW HD-22/30 Rear Panel Connections

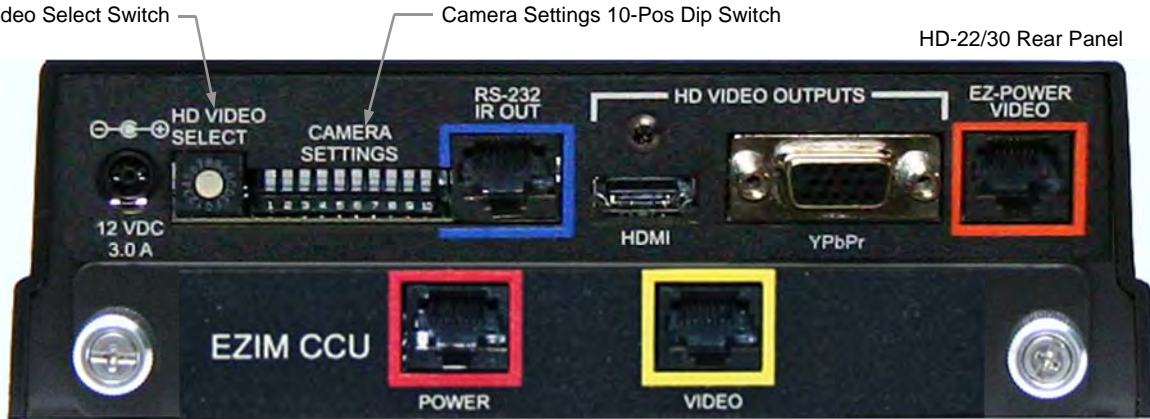

Drawing: Dip Switch and Resolution Label on the Bottom of the HD-22/30

| DIP SWITCH SETTINGS | | | | | | | | | | VIDEO RESOLUTION SELECT | | | |
|--------------------------|--------------------------|--------------------------|--------------------------|--------------------------|--------------------------|--------------------------|--------------------------|--------------------------|----|-------------------------|---|-------------|--|
| IR 1 1 & 2 UP | IR OUT OFF | 9600 bps | 5 OFF | 6 OFF | HDMI COLOR YCbCr | IMAGE FLIP OFF | 9 OFF | 10 OFF | 0 | 720p/59.94 | 8 | 576p/50 | |
| <input type="checkbox"/> | <input type="checkbox"/> | <input type="checkbox"/> | <input type="checkbox"/> | <input type="checkbox"/> | <input type="checkbox"/> | <input type="checkbox"/> | <input type="checkbox"/> | <input type="checkbox"/> | 1 | 1080i/59.94 | 9 | --- | |
| <input type="checkbox"/> | <input type="checkbox"/> | <input type="checkbox"/> | <input type="checkbox"/> | <input type="checkbox"/> | <input type="checkbox"/> | <input type="checkbox"/> | <input type="checkbox"/> | <input type="checkbox"/> | 2 | 1080p/59.94 | A | --- | |
| <input type="checkbox"/> | <input type="checkbox"/> | <input type="checkbox"/> | <input type="checkbox"/> | <input type="checkbox"/> | <input type="checkbox"/> | <input type="checkbox"/> | <input type="checkbox"/> | <input type="checkbox"/> | 3 | --- | B | --- | |
| <input type="checkbox"/> | <input type="checkbox"/> | <input type="checkbox"/> | <input type="checkbox"/> | <input type="checkbox"/> | <input type="checkbox"/> | <input type="checkbox"/> | <input type="checkbox"/> | <input type="checkbox"/> | 4 | 720p/50 | C | --- | |
| <input type="checkbox"/> | <input type="checkbox"/> | <input type="checkbox"/> | <input type="checkbox"/> | <input type="checkbox"/> | <input type="checkbox"/> | <input type="checkbox"/> | <input type="checkbox"/> | <input type="checkbox"/> | 5 | 1080i/50 | D | --- | |
| IR 2 ON | IR 3 ON | ON | 38400 bps | --- | --- | sRGB | ON | --- | 6 | 1080p/50 | E | 1080p/29.97 | |
| <input type="checkbox"/> | <input type="checkbox"/> | <input type="checkbox"/> | <input type="checkbox"/> | <input type="checkbox"/> | <input type="checkbox"/> | <input type="checkbox"/> | <input type="checkbox"/> | <input type="checkbox"/> | 7 | 480p/59.94 | F | 1080p/25 | |
| 1 | 2 | 3 | 4 | 5 | 6 | 7 | 8 | 9 | 10 | | | | |

- Set the desired and available HD output resolution for the camera with the Rotary Switch.
- Set the IR frequency of the camera if it is to respond to the IR remote control.
- If using the IR forwarding feature, set the IR OUT switch to ON (SW3).
- Set the Baud Rate dip switch (SW4) to 9600bps for most applications. Default for Vaddio EZCamera Cabling Systems is 9600bps.
- To set the HDMI or DVI color space, use dip switch 7 (SW7).
- If inverting the camera, turn the IMAGE FLIP ON (SW8).

Dip Switch Settings

- IR 1 & 2:** The IR remote has the capability of operating up to three different PTZ cameras from one remote. Use the selector buttons at the top of the IR remote to select the frequency.
- IR Out 3:** The IR output is sent out on the RS-232 RJ-45 jack on the back of the camera. Turning on the IR output will allow IR signals to be transmitted over the Cat-5 cable to the head end. When using RS-232 control or Vaddio CCU controllers (also via RS-232), turn the IR OUT to OFF (up).
- Baud Rate 4:** The options for baud rate are either 9600 bps or 38,400 bps.
- HDMI Color or sRGB Color space 7:** Default is YCbCr. Use sRGB color space with older DVI-D 1.0 monitors only. The YCbCr color space is best for HDMI digital video.
- Image Flip 8:** To invert the HD-20, turn the IMAGE FLIP ON (switch down).
- Switches 9 and 10:** Leave up - or in the OFF position

Anatomy of the Quick-Connect Universal CCU

The Universal CCU interfaces for the PowerVIEW HD-22 and the PowerVIEW HD-30 have very similar control protocols and share the same control keypad. The Universal CCU will automatically sense the camera it is and initialize the firmware for the connected camera. The next section will look at the controls and how they are laid out for easy access.

Image: Quick-Connect Universal CCU HD-22/30 Front Panel Controls



Front Panel Controls (left to right):

- **5-Line Blue Back-lit LED:** Displays up to control parameters at a time so the interrelationship of the controls can easily and quickly be read and understood.
- **Tally Light:** A contact closure on the back panel lights the blue LED on front panel indicating which Universal CCU and camera combination is the live Program in a multi-camera CCU installation. A tally command will also be sent to the camera via RS-232 to light the LED on cameras with on-board tally lights (Vaddio HD Series cameras).

Image: Close up View of the Universal CCU HD-22/30 Control Panel



HD-22/HD-30 Keypad Controls from (left to right): Touch the button with the parameter to be controlled and adjust the value with the encoder, then touch the cancel button to exit. When the rotary encoder button is touched, the SELECT and CANCEL menu buttons will illuminate to remind the user to either...select or cancel.

- **Scenes A, B & C:** Three camera adjustment scenes (A, B & C) can be stored into microprocessor memory. When lit (backlit blue button), the scene is activated. To store a scene, the user adjusts the controls and touches and holds the scene button down until the button blinks. To erase a scene press and hold the scene button and the cancel button.
- **Auto White Balance:** The Automatic White Balance controls/adjusts the color levels automatically when engaged. Take it out of Auto to manually adjust the Red and Blue levels.
- **OPWB (One Push White Balance):** When using OPWB, zoom in on a white subject (at least 60% of the image must be true white) touch the OPWB button and the coloration of the image will adjust to the white used in this shot.
- **Red & Blue Gain Controls:** The Red and Blue Gain buttons in combination with the encoder adjust the red and blue gain of the signal when Auto White Balance is disengaged.
- **Chroma:** Chroma controls the overall color saturation of the image.
- **PED:** This is the Pedestal or black level control for the HD-22/HD-30 cameras.
- **Gamma:** Gamma adjusts the overall brightness of an image to compensate for the perception of luminance and chroma.
- **Detail:** The Detail control sharpens or softens objects in the frame. Works well when looking at text.
- **IRIS - Auto or Manual:** The Auto Iris mode automatically adjusts the iris and gain of the camera. To manually adjust the iris or gain, turn off this control. The Manual Iris control allows the user to set the iris manually to one of the several settings available
- **Gain:** The Gain control boosts the signal level when the iris is open all the way, and there is not enough lighting available. To manually adjust the Gain, Auto Iris must be off. Use the Gain last to enhance the image.
- **Rotary Encoder:** Use the encoder to adjust values after the button is selected. This makes for very quick changes.
- **The Menu Buttons:** There are other screens to be accessed other than the camera control screen. Use the SELECT and CANCEL to enter other controls and exit other menus. These lights will illuminate for 10 Seconds, but no control operations are interrupted.

Image: Rear Panel CCU Connections and Controls (left to right)



- **Power Supply Input:** The Universal CCU uses a 36VDC, 2.78 Amp power supply on a 5.5mm OD x 2.5mm ID coaxial connector with a positive center.
- **36 VDC to Camera - RED RJ-45:** Power is provided on a Cat-5 cable to the RoboSHOT 36 VDC RJ-45 marked for CCU use only (see page 9). The power is regulated in the camera to 12 VDC.
- **RS-232 IN - GREY RJ-45:** RS-232 Input from ProductionVIEW™ console, Precision Camera Controller or other custom camera control system. Daisy Chain topology is not supported.
- **RS-232 to Camera - BLUE RJ-45:** RS-232 control is sent through this Cat-5 connection.
- **Local Tally on 2-pin Molex 5.0mm Euro-Style connector:** A contact closure lights the blue LED on front panel showing which Universal CCU and camera combination is the live Program in a multi-camera CCU installation. A tally command will also be sent to the camera via RS-232 to illuminate the LED on the cameras that have on-board tally lights.
- **Camera Feature Switches:** The CCU interface has an 8-position dip switch on the rear panel to allow for certain functionality. All switches should be in the down position for default.
 - **Dip Switch 1:** Put up to allow Scene A to load upon start-up or boot up.
 - **Dip Switch 5:** Put up to access LCD Display Menu settings including Display Mode, Bias and Contrast.
- **Video from Camera - YELLOW/ORANGE RJ-45:** The yellow RJ-45 receives the camera's differential video signals from the PowerVIEW's VIDEO RJ-45 on the EZIM CCU Slot Card (but there's no power on the cable). The orange EZ-POWER VIDEO RJ-45 on the PowerVIEW camera is not used (see drawings).
- **HD Video Outputs:** The Universal CCU has 3 (three) simultaneous video output formats that are the same resolution as the video inputs providing the ultimate in connectivity flexibility. The output formats include:
 - HD YPbPr on DE-15-F (HD15) - (supports up to/and including 1080p/60 - not limited)
 - HDMI on HDMI-F (supports up to and including 1080p/60)
 - HD-SDI on Edge Mount Carrier Class, Gold BNC-F (supports 3Gb/s Single Link 1080p/60 HD-SDI)



Big Important Note: The Quick-Connect Universal CCU supports the resolutions with frame rates of above 50 Hz (60, 59.94 and 50). Consequently, the 30, 29.97 and 25 fps from the Vaddio cameras are not supported

The EZIM (EZ Interface Module) HD-Series Slot Card

The EZIM Slot Card fits into the slot into the base of each of the HD-22 and HD-30 HD PTZ cameras and terminates the Power (red) Cat-5 cable and the Video (yellow) Cat-5 cable to the camera (see colors above).



Please remove power from the camera prior to inserting, seating and screwing down the card with the attached thumb screws. Hot swapping is generally advised, so please...turn the camera off before inserting the slot Card.

Image: EZIM Slot Card



EZIM CCU Slot Card (Front View)

The HD-22 and HD-30 Control Menu Screens

The HD-22 and HD-30 have individual firmware that auto loads when the camera is plugged in to the Universal CCU and the CCU is turned on (turn the camera on first). Since most cameras are a bit different, the menus will be slightly different, but the Firmware is the same for the HD-22 and HD-30. The menus are organized as follows:

Image: Menu Organization HD-22/30

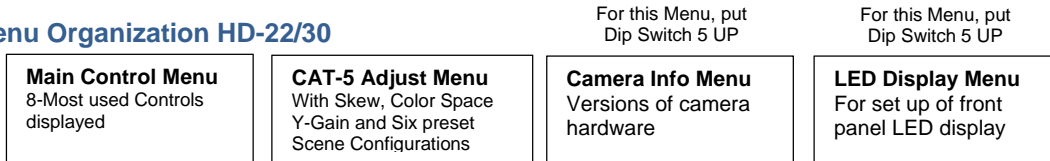

The HD-22 and HD-30 individual control screens are very similar, only differing in lens magnification and product name. Both cameras will perform well for low light, conferencing and large room applications.

The Main Menu screen shows eight (8) prominent parameters at a time. For both cameras, the BRIGHT key will actually read out on the display as PEDESTAL. This control is actually PEDESTAL and the display is correct. The button will be eventually changed to read PED (since pedestal won't fit).

Main Menu Pages HD-22

| | | | |
|------------------|------------|---------------|-------------|
| CAT-5 CCU | | HD-22 | |
| RED | 65 | GAMMA | 1 |
| BLUE | 75 | DETAIL | 44 |
| CHROMA | 190 | IRIS | AUTO |
| PEDESTAL | 111 | GAIN | AUTO |

Main Menu Pages HD-30

| | | | |
|------------------|-------------|---------------|-------------|
| CAT-5 CCU | | HD-30 | |
| RED | AUTO | GAMMA | 1 |
| BLUE | AUTO | DETAIL | 44 |
| CHROMA | 190 | IRIS | AUTO |
| PEDESTAL | 111 | GAIN | AUTO |

The Cat-5 Adjustment Menu allows the user to adjust the skew of the Cat-5 Cable (1 to 16), to compensate for differing Cat-5 cable lengths between camera and CCU. This setting will usually be best in the middle of the range of skew numbers which pass acceptable video. Set the HDMI Color Space to YCbCr for HDMI and to sRGB for DVI-D output. The Y-Gain is for adjusting the video ± 10 IRE at all outputs as needed for associated equipment. Preset Lighting Scene Configurations offer sample settings for fluorescent, incandescent and outdoor lighting environments. Choose the scene (shown in the Screen Config description below) which looks best for your situation and fine tune from there.

The Cat-5 Adjustment menu uses the "@" sign for the cursor and the ">" when selected.

Cat-5 Adjustment Menu HD-22/30 with Scene >1: AUTO

| | | | |
|------------------|--------------|---------------------|--|
| CAT-5 CCU | | HD-22 | |
| @Skew | 1 | Scene Config | |
| HDMI | YCbCr | >1: AUTO | |
| YGain | Def | | |

Cat-5 Adjustment Menu HD-22/30 with Scene >4: Fluorescent High

| | | | |
|------------------|--------------|------------------------|--|
| CAT-5 CCU | | HD-30 | |
| Skew | 1 | Scene Config | |
| @HDMI | YCbCr | >4: Fluor Hi | |
| YGain | Def | | |

Scene Configuration:

Generalized Scene Configurations have been added to allow the user to quickly run through preset lighting environment scenes, and include the following presets:

- 1) AUTO (full Auto)
- 2) Incand Lo (incandescent low)
- 3) Incand Hi (incandescent high)
- 4) Fluor Lo (fluorescent low)
- 5) Fluor Hi (fluorescent high)
- 6) Outdoor

The Version Menu screen displays the software versions of the Vaddio cameras attached as a convenience to the operator. The versions shown include the zoom module, the motors and the camera.

Version Display Menu



Put dip switch #5 UP to access this menu where the firmware versions of the CCU, camera and motors are displayed. The FPGA date is also displayed

The Display Menu provides controls for the blue LED display, including Bias (brightness), Display Mode - Normal (negative mode) and Inverted (positive mode) and overall contrast are provided. Put dip switch #5 UP to access this menu, make the adjustment and it is recommended that dip switch #5 is returned to the DOWN position so this menu is no longer seen.

Display Menu

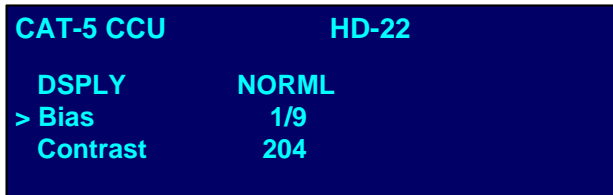

Put dip switch #5 UP to access the Display Menu.

Installation Basics:

The WallVIEW CCU system was specifically designed for installation on a vertical wall surface with Cat-5 cable connectivity for Video, Power and Control signaling (three Cat-5 cables are required). Installation is simplified in that no custom 8-Pin mini-din cables or expensive plenum coax cables are needed and no power outlets are required near the camera bracket. All cabling is routed to the head-end using Cat-5 cables with standard straight through RJ-45 connectors (568B termination). *“Pass-thru” type RJ-45 connectors, as a rule should be avoided like a bad cliché.*



General Installation Instructions for the CONCEAL Wall Mounting System:

Step 1: Determine Camera Mount Location

When locating the camera, consider viewing angles, lighting conditions, possible line of site obstructions and check for in-wall obstructions where the camera is to be mounted. Pick a mounting location to optimize the performance of the camera. After determining the optimum location of the camera system, route the required three (3) Cat-5 cables from the camera to the head-end. Mark the Cables: POWER, VIDEO and CONTROL.

The three (3) Cat-5 cables should feed-through a 1” (25.4mm) opening (circular or square shape) centered in the rectangular slot located on the rear flange of the CONCEAL Wall Mount Bracket.



Note: Do not cut out the entire rectangular slot opening in the wall! This will not allow the two lower wall anchors to correctly fasten the Conceal Wall Mount to the wall.

If the bracket is to be mounted on a 2-gang wall box, use the screws supplied with the wall box cover plate to attach the CONCEAL Wall Mount Bracket. If mounting to drywall with wall anchors, use the four (4) quality wall anchors/screws provided

Note: The mounting holes are slotted and are 90° opposing to provide easy leveling. Level the mount and tighten the mounting screws.

The example of the CONCEAL mount shows an HD-18, but the steps are identical for the HD-22 or HD-30.



CONCEAL Wall Mount Bracket:
Cabled and Attached to Wall



Fig. 2: Camera aligned and attached to the CONCEAL Wall Mount Bracket (by two-(1/4”-20) screws in the bottom of the mount).



Note: Check all Cat-5 cables for continuity in advance of final connection. Plugging the POWER Cat-5 cable into the wrong RJ-45 may cause damage to the camera system and void the warranty!

Step 2: System Wiring

Follow the sample wiring diagrams for connecting the Cat-5 cables to the camera and Quick-Connect Universal CCU Interface. Additional diagrams are available on the Vaddio website.

Connect the camera side as follows:

- Connect the POWER Cat-5 to the Power RJ-45 on the EZIM CCU Slot Card.
- Connect the VIDEO Cat-5 to the Video RJ-45 on the EZIM CCU Slot Card.
- Connect the RS-232 control Cat-5 to the “RS-232 IN” RJ-45 on the top row of connectors on the camera.

Connect the Universal CCU side as follows:

- Connect the VIDEO Cat-5 cable to the VIDEO FROM CAMERA RJ-45 jack (yellow) on the CCU.
- Connect the RS-232 Cat-5 cable to the RS-232 TO CAMERA RJ-45 (Blue) on the CCU.
- Wait to connect the POWER Cat-5 cable until later.

Step 3: Secure the Camera To the CONCEAL Wall Mount Bracket

After all cables are attached to the camera, place the camera onto the camera mount and insert the two 1/4"-20 screws into the camera through the two-screw holes in the bottom of the mount. **Note:** Be sure to align each side of the camera evenly to all sides of the CONCEAL Wall Mount Bracket before final tightening of the mounting screws.

Step 4: Install the CONCEAL Lower Cover Plate

Attach the CONCEAL lower cover plate. Slide lower cover plate from front of the mounting bracket toward the rear of the bracket. The two (2) rear locking tabs will need to be guided into position first and will lock in place as the lower cover plate is pushed toward the rear of the mounting bracket and the front two (2) tabs are inserted.

CONCEAL Lower Cover Plate with Locking Tabs



CONCEAL Lower Cover Plate locked in place



Step 5: Install the CONCEAL Rear Camera Cover

After successful testing of the camera, install the CONCEAL rear camera cover on the mounting bracket with the supplied screw (see Fig. 5 and 6).

CONCEAL Rear Camera Cover



Completed CONCEAL Wall Mount Camera Bracket Installation



NOTE (One more time!): Check all Cat-5 cables for continuity in advance of the final connection. Label the Cat-5 cables. Plugging the POWER cable into the wrong RJ-45 may cause damage to the camera system and void the warranty.

Step 6: Connect System Power

Connect the Vaddio 36 VDC power supply to the Quick-Connect Universal CCU Interface and an AC outlet. The CCU will power the camera via the Cat-5 cable. The camera will "Home" to a centered position ready for control information from the Universal CCU. To ensure proper continuity of control and operation of the cameras, the RS-232 controller (control system or joystick) should be powered on after the camera(s).

Drawing: Basic System Connectivity
Wiring Diagram Example:

Rear Panel of HD-22 with EZIM CCU Slot Card installed in the bottom row slot. All Universal CCU camera packages are shipped with the EZIM CCU Slot Card.

Please see the manuals for each of the cameras for specifics regarding set-up and switch settings.

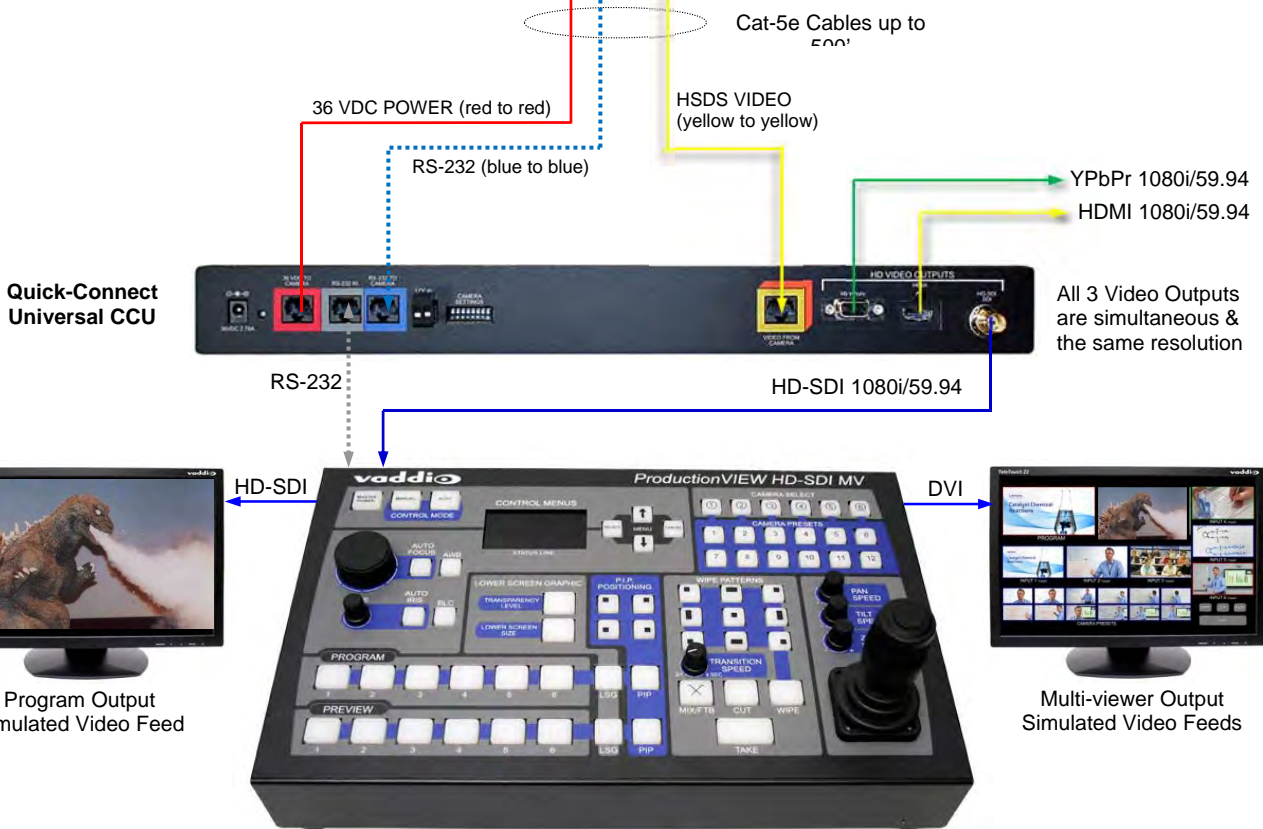
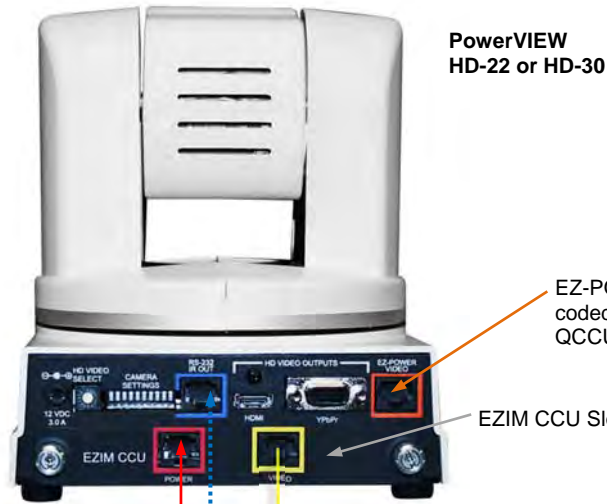

System Configuration Notes:

The Quick-Connect Universal CCU System uses a full Cat-5 (all 4-pairs) for POWER to ensure the motors of the camera receive the required current to operate properly. The VIDEO Cat-5 cable uses all four pairs for video. The RS-232 Cat-5 provides communication to the camera for CCU and PTZ control. These Cat-5 cables can be run up to 500' (152.4m). See Appendix 1 for wiring and pin-out information. **NOTE:** Daisy-Chain configurations are not supported.

Optimizing System Performance:

Optimizing the CCU settings will help achieve maximum performance from the system. Difficult lighting is one of the most challenging problems video system integrators face. The Vaddio CCU will provide the flexibility to fine tune for variables such as cable length, day/night lighting transitions and lighting color temperature.



1. **Adjust Y Gain:** Allows for the adjustment of luminance gain up to +/- 10% as needed to compensate for a too light or dark image in downstream equipment.
2. **Set skew control:** Adjust to afford the best picture brightness, quality and clarity. The range is 0-16. There will typically be a range of values where the video will output a valid image. The best setting is usually achieved with a number roughly in the middle of this valid video range.
3. **Adjust Iris and Digital Gain Settings:** Disable Auto Iris. Set the Iris to its largest aperture (lowest 'f' number). Adjust the Gain until the image is too dark and then bring it back until it is properly exposed. Exposures that require high gain settings will have a grainy video image. Adjust the detail settings for a smoother image.
4. **Adjust Color to Taste:** Required adjustments will vary based on the environment. The CCU allows the set-up of three (3) scenes so settings are available for a variety of conditions. Adjust the Chroma level to taste. Adjust Red/Blue levels next. Adjusting for skin tones or using a color chart is an easy way to find a good baseline setup.



Changing the HD Resolution of the HD-22 and HD-30: When changing the resolution of the HD-22 and HD-30 cameras, the camera may need to be power-cycled. This ensures that all of the settings for that resolution are intact. If the camera resolution is changed while connected to a video switcher (even the expensive ones), the switcher will need to be reset to that resolution and most probably power cycled while the camera is on. The boot order method when connecting a camera to a 3rd party video switcher is:

- a) Set the camera's output resolution
- b) Set the switcher's input resolution
 - Make sure these resolutions match!
- c) Turn on the Universal CCU and Camera System (let it boot up completely and Home)
- d) Turn on the 3rd party video switcher

General Specifications: (Note: Specifications and pricing are subject to change without prior notice or obligation.)

| Camera | PowerVIEW HD-22 PTZ | PowerVIEW HD-30 PTZ |
|---------------------------|---|--|
| Part Numbers | 999-6960-000 (North America) 999-6960-001 (Int'l) | 999-6970-000 (North America) 999-6970-001 (Int'l) |
| Zoom | 22X Optical Zoom | 30X Optical Zoom |
| Field of View | Horizontal: 65.2° Wide End to 3.1° Tele (16:9 Aspect Ratio) | Horizontal: 65° Wide End to 2.2° Tele (16:9 Aspect Ratio) |
| Lens Focal Length | f=4.3 mm to 94.6 mm / F1.6 - F4.7 | f=4.3mm to 129.0 mm / F1.6- F4.7 |
| Image Sensor | 1/2.8-Type MOS, 2.2 Megapixel, Progressive Scan | |
| Minimum Illumination | Color: 0.4 lux (F1.6, 1/30 sec, 50 IRE, Gain: High), B/W: 0.04 lux (F1.6, 1/30 sec, 50 IRE, Gain: High) | |
| Video Resolutions | HD: 1080p/59.94, 1080p/50, 1080p/29.97/25, 1080i/59.94, 1080i/50, 720p/59.94, 720p/50 | |
| Video Output Formats | HDMI (YCbCr for HDMI and sRGB for DVI), Analog Component (YPbPr) HSDS (Power, Differential HD Video & R\$S-232 Control) | |
| Signal to Noise Ratio | > 50 dB (AGC: Off) | |
| Compatible Quick-Connects | Quick-Connect SR, Quick-Connect DVI/HDMI SR, Quick-Connect Universal CCU and Quick-Connect USB (varying voltages), USB Mini | |
| Pan Range | Pan: +170 degrees to -170 degrees Tilt: +90 degrees to -30 degrees | |
| Preset Positions | 16 (internal), 6 recalled via Vaddio IR Remote Commander | |
| Image Control | Red & Blue Gain, Detail, Chroma, Gamma, Pedestal, Iris, and Gain (Controls available through RS-232 control and Quick-Connect CCU and Slot Card) | |
| Tally Light | Available through RS-232 Control | |
| HD Video Select | 16-Position Rotary Switch: Used to set HD Video Resolution Output | |
| Camera Settings | 10-Position Dip Switch: Settings for IR Select, Baud Rate 9600, Image Flip, Unpublished Functions | |
| Accessory Slot Cards | EZIM CCU Slot Card PN# 999-6900-006 - For Use with Quick-Connect CCU Only | |
| Dimensions/Weight | 7.81" (198.37mm) H x 6.67" (169.42mm) W x 7.057" (179.25. mm) D / 5.6 lbs. (2.630835643 kg.) | |

Quick-Connect Universal CCU

| | |
|---|--|
| Connectors | <ul style="list-style-type: none"> Power Connector: 5.5mm OD x 2.5mm ID Power RJ-45: Supplies 36V to EZIM Slot Card RS-232 IN RJ-45: Accepts RS-232 from ProductionVIEW or other control systems RS-232 OUT RJ-45: Passes RS-232 and Sync video feed to camera EZIM Tally: 2-Pin Phoenix type spring cage connector Video From Camera RJ-45: Accepts differential video from EZIM Slot Card Video Outputs: <ul style="list-style-type: none"> HD-YPbPr on DE-15-F connector HDMI on HDMI-F connector HD-SDI on Edge Mount Carrier Class, Gold BNC-F, supports 3Gb/s Single Link 1080p/60 |
| Camera Settings DIP Switch | <p>All switches should be in the down position for default.</p> <ul style="list-style-type: none"> DIP Switch 1: Put up to allow Scene A to load upon start-up or boot up. DIP Switch 5: Put up to access LCD Display Menu settings including Display Mode (Negative Mode-Default or Positive Mode), Bias (Brightness) and Contrast. DIP Switches 2, 3, 4, 6, 7 & 8: NA for HD-22 anHD-30 |
| Video Adjustments | Y-Gain (+/- up to 10 IRE luminance gain) for fine tuning over longer cable distances Skew for cabling distance compensation: |
| Cat-5 Cable Distance | Up to 500' (152.4m), Maximum |
| Power Supply | 36 VDC, 2.78 Amp |
| Dimensions | 1-RU Rack Mount - 1.72" H x 18.93" W x 7" D (43.7mm x 480.1mm x 177.8mm) Rack Ears Included |
| EZIM (EZCamera Interface Module) Slot Card | |
| Connectors | Two (2) RJ-45 Connectors For Power and HSDS Video |

Moon in Front Page Header: Titania, Largest Moon of the planet Uranus.

Warranty Information:

(See Vaddio Warranty, Service and Return Policies posted on vaddio.com for complete details)

Hardware* Warranty: Two (2) year limited warranty on all parts and labor for Vaddio manufactured products. Vaddio warrants its manufactured products against defects in materials and workmanship for a period of two years from the day of purchase, to the original purchaser, if Vaddio receives notice of such defects during the warranty. Vaddio, at its option, will repair or replace products that prove to be defective. Vaddio manufactures its hardware products from parts and components that are new or equivalent to new in accordance with industry standard practices.

Exclusions: The above warranty shall not apply to defects resulting from improper or inadequate maintenance by the customer, customers applied software or interfacing, unauthorized modifications or misuse, mishandling, operation outside the normal environmental specifications for the product, use of the incorrect power supply, modified power supply or improper site operation and maintenance. OEM products and products manufactured by other companies are excluded and are covered by the manufacturer's warranty

Vaddio Customer Service: Vaddio will test, repair, or replace the product or products without charge if the unit is under warranty. If the product is out of warranty, Vaddio will test then repair the product or products. The cost of parts and labor charge will be estimated by a technician and confirmed by the customer prior to repair. All components must be returned for testing as a complete unit. Vaddio will not accept responsibility for shipment after it has left the premises.

Vaddio Technical Support: Vaddio technicians will determine and discuss with the customer the criteria for repair costs and/or replacement. Vaddio Technical Support can be contacted through one of the following resources: e-mail support at support@vaddio.com or online at www.vaddio.com.

Return Material Authorization (RMA) Number: Before returning a product for repair or replacement request an RMA from Vaddio's technical support. Provide the technician with a return phone number, e-mail address, shipping address, product serial numbers and original purchase order number. Describe the reason for repairs or returns as well as the date of purchase. See the General RMA Terms and Procedures section for more information. RMA's are valid for 30 days and will be issued to Vaddio dealers only. End users must return products through Vaddio dealers. Include the assigned RMA number in all correspondence with Vaddio. Write the assigned RMA number clearly on the shipping label of the box when returning the product. All products returned for credit are subject to a restocking charge without exception.

Voided Warranty: The warranty does not apply if the original serial number has been removed or if the product has been disassembled or damaged through misuse, accident, modifications, use of incorrect power supply, use of a modified power supply or unauthorized repair.

Shipping and Handling: Vaddio will not pay for inbound shipping transportation or insurance charges or accept any responsibility for laws and ordinances from inbound transit. Vaddio will pay for outbound shipping, transportation, and insurance charges for all items under warranty but will not assume responsibility for loss and/or damage by the outbound freight carrier. If the return shipment appears damaged, retain the original boxes and packing material for inspection by the carrier. *Contact your carrier immediately.*

Products not under Warranty: Payment arrangements are required before outbound shipment for all out of warranty products.

Other General Information:

Care and Cleaning

Do not attempt to take this product apart at any time. There are no user-serviceable components inside.

- Do not spill liquids in the product.
- Keep this device away from food and liquid.
- For smears or smudges on the product, wipe with a clean, soft cloth.
- Use a quality lens cleaning cloth on the lens
- Do not use any abrasive chemicals.

Operating and Storage Conditions:

Do not store or operate the device under the following conditions:

- Temperatures above 40°C (104°F) or temperatures below 0°C (32°F)
- High humidity, condensing or wet environments
- In swimming pools with movie stars (privacy issue)
- In inclement weather
- Dry environments with an excess of static discharge
- In an underwater igloo or beaver dam
- Under severe vibration

Compliance and CE Declaration of Conformity - PowerVIEW HD-22 and HD30

Compliance testing was performed to the following regulations:

- **FCC Part 15 (15.107, 15.109), Subpart B**
- **ICES-003, Issue 4: 2004**
- **EN 55022 A: 2006 + A1: 2007**
- **KN24 2008 (CISPR 24: 1997 + A1: 2000 + A2: 2002)**
- **KN22 2008 (CISPR 22: 2006)**
- **EMC Directive 2004/108/EC**
- **EN 55024: A2: 2003**

- Class A
- Class A
- Class A
- Class A
- Class A
- Class A
- Class A



FCC Part 15 Compliance

This equipment has been tested and found to comply with the limits for a Class A digital device, pursuant to Part 15, Subpart B, of the FCC Rules. These limits are designed to provide reasonable protection against harmful interference when the equipment is operated in a commercial environment. This equipment generates, uses, and can radiate radio frequency energy and, if not installed and used in accordance with the instruction manual, may cause harmful interference to radio communications. Operation of this equipment in a residential area is likely to cause harmful interference in which case the user will be required to correct the interference at his/her own expense.

Operation is subject to the following two conditions: (1) This device may not cause interference, and (2) This device must accept any interference including interference that may cause undesired operation of the device. Changes or modifications not expressly approved by Vaddio can affect emission compliance and could void the user's authority to operate this equipment.



ICES-003 Compliance

This digital apparatus does not exceed the Class A limits for radio noise emissions from digital apparatus set out in the Radio Interference Regulations of the Canadian Department of Communications.

Le présent appareil numérique n'émet pas de bruits radioélectriques dépassant les limites applicables aux appareils numériques de la classe A prescrites dans le Règlement sur le brouillage radioélectrique édicté par le ministère des Communications du Canada.



European Compliance

This product has been evaluated for Electromagnetic Compatibility under the EMC Directive for Emissions and Immunity and meets the requirements for a Class A digital device. In a domestic environment this product may cause radio interference in which case the user may be required to take adequate measures.

Standard(s) To Which Conformity Is Declared:

EMC Directive 2004/108/EC

EN 55022 A: 2006 + A1: 2007(CISPR 22:2005/A1:2005)

EN 55024: 1998 + Amendments A1: 2001 + A2: 2003

- EN 61000-4-2: 1995 + Amendments A1: 1998 + A2: 2001
- EN 61000-4-3: 2006 + A1: 2008
- EN 61000-4-4: 2004 + Corrigendum 2006
- EN 61000-4-5: 2006
- EN 61000-4-6: 2009
- EN 61000-4-8: 2010
- EN 61000-4-11: 2004

KN24 2008 (CISPR 24: 1997 + A1: 2000 + A2: 2002)

- KN 61000-4-2
- KN 61000-4-3
- KN 61000-4-4
- KN 61000-4-5
- KN 61000-4-6
- KN 61000-4-8
- KN 61000-4-11

IEC 60950-1:2005 (2nd Edition); Am 1:2009

EN 60950-1:2006+A11:2009+A1:2010+A12:2011

- Radiated and Conducted Emissions
- Immunity
- Electrostatic Discharge
- Radiated Immunity
- Electrical Fast Transients
- Surge Immunity
- Conducted Immunity
- Power Frequency Magnetic Field
- Voltage Dips, Interrupts and Fluctuations
- IT Immunity Characteristics
- Electrostatic Discharge
- Radiated Immunity
- Electrical Fast Transients
- Surge Immunity
- Conducted Immunity
- Power Frequency Magnetic Field
- Voltage Dips, Interrupts and Fluctuations
- Safety
- Safety



Compliance and CE Declaration of Conformity - Universal CCU and EZIM CCU

Compliance testing was performed to the following regulations:

- **FCC Part 15**, Subpart B
- **ICES-003**, Issue 4: 2004
- European Standard **EN 55022 A**: October 2007
- European Standard **EN 55024/A2** January 2003
- **IEC 60950-1:2005** (Second Edition); Am 1:2009
- **EN 60950-1:2006+A11:2009+A1:2010+A12:2011**
- **EMC Directive 89/336/EC**



- Class A
- Class A
- Class A
- Class A
- Safety
- Safety
- Class A



FCC Part 15 Compliance

This equipment has been tested and found to comply with the limits for a Class A digital device, pursuant to Part 15, Subpart B, of the FCC Rules. These limits are designed to provide reasonable protection against harmful interference when the equipment is operated in a commercial environment. This equipment generates, uses, and can radiate radio frequency energy and, if not installed and used in accordance with the instruction manual, may cause harmful interference to radio communications. Operation of this equipment in a residential area is likely to cause harmful interference in which case the user will be required to correct the interference at his/her own expense.

Operation is subject to the following two conditions: (1) This device may not cause interference, and (2) This device must accept any interference including interference that may cause undesired operation of the device.

Changes or modifications not expressly approved by Vaddio can affect emission compliance and could void the user's authority to operate this equipment.



ICES-003 Compliance

This digital apparatus does not exceed the Class A limits for radio noise emissions from digital apparatus set out in the Radio Interference Regulations of the Canadian Department of Communications.

Le présent appareil numérique n'émet pas de bruits radioélectriques dépassant les limites applicables aux appareils numériques de la classe A prescrites dans le Règlement sur le brouillage radioélectrique édicté par le ministère des Communications du Canada.



European Compliance

This product has been evaluated for Electromagnetic Compatibility under the EMC Directive for Emissions and Immunity and meets the requirements for a Class A digital device. In a domestic environment this product may cause radio interference in which case the user may be required to take adequate measures.

Standard(s) To Which Conformity Is Declared:

EMC Directive 89/336/EC

EN 55022 A: 1998 + A1: 2000

EN 55024: 1998 + Amendments A1: 2001 + A2: 2002

- EN 61000-4-2:
- EN 61000-4-3:
- EN 61000-4-4:
- EN 61000-4-5:
- EN 61000-4-6:
- EN 61000-4-8:
- EN 61000-4-11

Conducted and Radiated Emissions

Immunity

Electrostatic Discharge

Radiated Immunity

Electrical Fast Transients

Surge Immunity

Conducted Immunity

Power Frequency Magnetic Field

Voltage Dips, Interrupts and Fluctuations

IEC 60950-1:2005 (Second Edition); Am 1:2009

EN 60950-1:2006+A11:2009+A1:2010+A12:2011

Safety

Safety

Appendix 1: Cable Pin-outs for the Quick-Connect CCU System

Quick-Connect CCU Pin-out Assignments:



Power Connector RJ-45 (Red)

| Pin # | Function | Pairs |
|---------|----------|-------|
| Pin - 1 | Power + | 1 |
| Pin - 2 | Power - | 1 |
| Pin - 3 | Power + | 2 |
| Pin - 4 | Power - | 3 |
| Pin - 5 | Power + | 3 |
| Pin - 6 | Power - | 2 |
| Pin - 7 | Power + | 4 |
| Pin - 8 | Power - | 4 |

36 VDC TO CAMERA

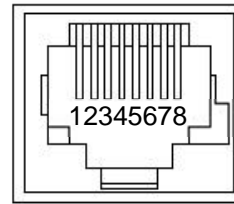

RS-232 IN RJ-45 (Green)

| Pin # | Function | Pairs |
|---------|----------------------------------|----------|
| Pin - 1 | N/A | Not Used |
| Pin - 2 | N/A | Not Used |
| Pin - 3 | N/A | Not Used |
| Pin - 4 | N/A | Not Used |
| Pin - 5 | N/A | Not Used |
| Pin - 6 | Digital GND | |
| Pin - 7 | RXD (from TXD of control source) | 4 |
| Pin - 8 | TXD (to RXD of control source) | 4 |

RS-232 IN

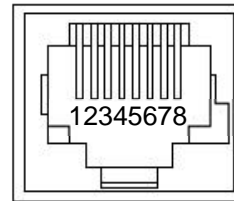

RS-232 OUT RJ-45 (Blue)

| Pin # | Function | Pairs |
|---------|----------------------------------|----------|
| Pin - 1 | N/A | Not Used |
| Pin - 2 | N/A | Not Used |
| Pin - 3 | N/A | Not Used |
| Pin - 4 | N/A | Not Used |
| Pin - 5 | N/A | Not Used |
| Pin - 6 | Digital GND | |
| Pin - 7 | TXD (to RXD of control source) | 4 |
| Pin - 8 | RXD (from TXD of control source) | 4 |

RS-232 TO CAMERA

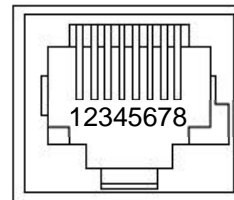

Video (HSDS-differential) RJ-45 (Yellow)

| Pin # | Function | Pairs |
|---------|----------|----------|
| Pin - 1 | N/A | Not Used |
| Pin - 2 | N/A | Not Used |
| Pin - 3 | Y+ | 2 |
| Pin - 4 | PB+ | 3 |
| Pin - 5 | PB GND | 3 |
| Pin - 6 | Y GND | 2 |
| Pin - 7 | PR+ | 4 |
| Pin - 8 | PR- | 4 |

VIDEO FROM CAMERA

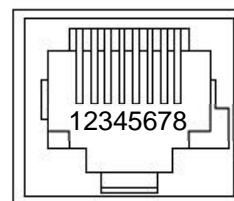

Appendix 1 (continued)
EZIM Slot Card Pin-out Assignments



Power Connector RJ-45 (Red)

| Pin # | Function | Pairs |
|---------|----------|-------|
| Pin - 1 | Power + | 1 |
| Pin - 2 | Power - | 1 |
| Pin - 3 | Power + | 2 |
| Pin - 4 | Power - | 3 |
| Pin - 5 | Power + | 3 |
| Pin - 6 | Power - | 2 |
| Pin - 7 | Power + | 4 |
| Pin - 8 | Power - | 4 |

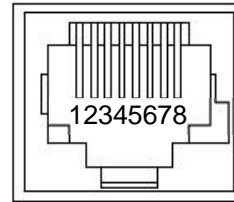

POWER

Video (HSDS-differential) RJ-45

| Pin # | Function | Pairs |
|---------|----------|----------|
| Pin - 1 | N/A | Not Used |
| Pin - 2 | N/A | Not Used |
| Pin - 3 | Y+ | 2 |
| Pin - 4 | PB+ | 3 |
| Pin - 5 | PB GND | 3 |
| Pin - 6 | Y GND | 2 |
| Pin - 7 | PR+ | 4 |
| Pin - 8 | PR- | 4 |

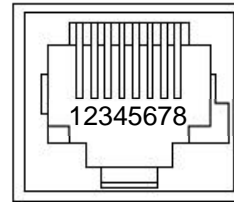

VIDEO

Table: New Commands for the CCU Scene Selection

| Command Set | Command | Command Packet | Comments |
|-------------|---------|----------------------|----------------------------|
| QCCUScenes | Reset | 8x 01 04 3F 00 7p FF | p: Scene Number =1, 2 or 3 |
| | Set | 8x 01 04 3F 01 7p FF | |
| | Recall | 8x 01 04 3F 02 7p FF | |

Notes:

For use with Quick-Connect Universal CCU (QCCU), which no daisy-chain operation is allowed, the Command packet will be **81 01 043F 00 7p FF** (where the p is scene 1, 2 or 3.)

A Vaddio PTZ camera must be connected to the QCCU for the scene Set, Recall, and Reset to operate correctly. This command set communicates with the QCCU and the camera simultaneously.

Appendix 2: PowerVIEW EZ-Power Video RJ-45 Connector Pin-outs



Important Note: The EZ-Power Video RJ-45 Connector is for use with the **Quick-Connect SR, Quick-Connect DVI/HDMI SR and Quick-Connect USB Interfaces ONLY** (568B Wiring Standard). The video signals are differential (HSDS™) and can only be received by the interfaces above. The Universal CCU Power and Video connections are on the **EZIM CCU Slot Card ONLY**

| Pin | YPbPr |
|-----|--------|
| 1 | Power+ |
| 2 | Power- |
| 3 | Y+ |
| 4 | PB+ |
| 5 | PB - |
| 6 | Y - |
| 7 | PR+ |
| 8 | PR- |

EZ-POWER VIDEO

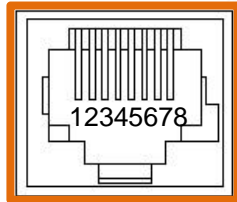

Drawing: PowerVIEW HD-22/30 Dimensions

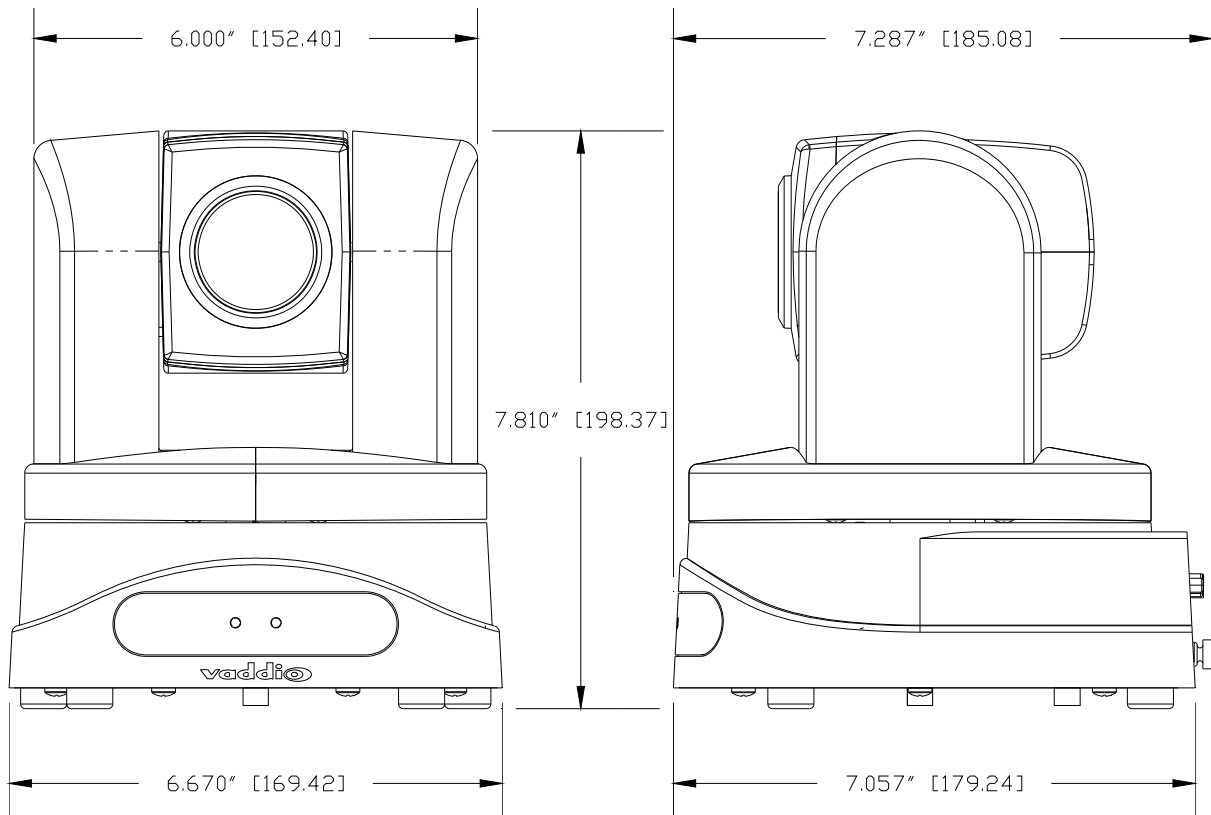

Appendix 3: Communication Specification

Communication Speed: 9600 bps (default)

Start bit: 1
 Stop bit: 1
 Data bits: 8
 Parity: None
 No Flow control

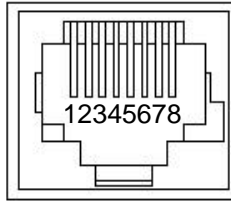

| Pin # | RJ-45 RS-232 and IR Out Pins |
|-------|---|
| 1) | Unused |
| 2) | Unused |
| 3) | Unused |
| 4) | IR Output (Diff Signal to Quick-Connect SR) |
| 5) | IR Ground (Diff Signal to Quick-Connect SR) |
| 6) | GND (GND of IR Short Range - Pin 3) |
| 7) | RXD (from TXD of control source) |
| 8) | TXD (to RXD of control source) |

NOTE: The Vaddio PowerVIEW HD-22 and 30Control Protocol is similar, but not identical to, the Sony® VISCA™ command set in order to be compatible with several popular control devices. Not all VISCA commands are supported and there are many HD-22/30 specific commands in the following Command and Inquiry Lists.

HD-22/30 Command List (1/2)

| Command Set | Command | Command Packet | Comments |
|----------------|---|--|---|
| Address Set | Broadcast | 88 30 01 FF | Address Set (Daisy chain) |
| IF_Clear | Broadcast | 88 01 00 01 FF | IF Clear |
| Command Cancel | | 8x 2p FF | p:socket number(1,2) |
| CAM_Power | On Off(Standby) | 8x 01 04 00 02 FF 8x 01 04 00 03 FF | Power On/Off |
| CAM_Zoom | Stop Tele(Standard) Wide(Standard) Tele(Variable) Wide(Variable) Direct | 8x 01 04 07 00 FF 8x 01 04 07 02 FF 8x 01 04 07 03 FF 8x 01 04 07 2p FF 8x 01 04 07 3p FF 8x 01 04 47 00 0p 0q 0r FF | p:(1-Slow to 4-Fast) p:(1-Slow to 4-Fast) pqr: Zoom Position* |
| CAM_Focus | Stop Far(Standard) Near(Standard) Far(Variable) Near(Variable) AutoFocus ManualFocus Auto/Manual Direct | 8x 01 04 08 00 FF 8x 01 04 08 02 FF 8x 01 04 08 03 FF 8x 01 04 08 2p FF 8x 01 04 08 3p FF 8x 01 04 38 02 FF 8x 01 04 38 03 FF 8x 01 04 38 10 FF 8x 01 04 48 0p 0q 0r 0s FF | p:(1-Slow to 4-Fast) p:(1-Slow to 4-Fast) pqrs: Focus position(0-0x438)* |
| CAM_WB | Auto Indoor Outdoor One Push WB Manual Fluorescent One Push Trigger | 8x 01 04 35 00 FF 8x 01 04 35 01 FF 8x 01 04 35 02 FF 8x 01 04 35 03 FF 8x 01 04 35 05 FF 8x 01 04 35 06 FF 8x 01 04 10 05 FF | Normal Auto (Auto Tracing WB) Indoor Mode (Color Temp 3200K) Outdoor Mode (Color Temp 5600K) One Push White Balance Mode Manual White Balance Fluorescent(Color Temp 4200K) One Push WB Trigger |
| CAM_RGain | Reset Up Down Direct | 8x 01 04 03 00 FF 8x 01 04 03 02 FF 8x 01 04 03 03 FF 8x 01 04 43 00 00 0p 0q FF | pq:00-ff |
| CAM_BGain | Reset Up Down Direct | 8x 01 04 04 00 FF 8x 01 04 04 02 FF 8x 01 04 04 03 FF 8x 01 04 44 00 00 0p 0q FF | pq:00-ff |
| CAM_AE | Full Auto Manual | 8x 01 04 39 00 FF 8x 01 04 39 03 FF | Auto Exposure Mode Manual Control Mode |
| CAM_Iris | Reset Up Down Direct | 8x 01 04 0B 00 FF 8x 01 04 0B 02 FF 8x 01 04 0B 03 FF 8x 01 04 4B 00 00 0p 0q FF | pq(0x00-0xFF) |
| CAM_Gain | Reset Up Down Direct | 8x 01 04 0C 00 FF 8x 01 04 0C 02 FF 8x 01 04 0C 03 FF 8x 01 04 4C 00 00 0p 0q FF | pq(0x00-0xFF) |
| CAM_Backlight | On Off | 8x 01 04 33 02 FF 8x 01 04 33 03 FF | |
| CAM_Aperture | Reset Up Down Direct | 8x 01 04 02 00 FF 8x 01 04 02 02 FF 8x 01 04 02 03 FF 8x 01 04 42 00 00 0p 0q FF | pq(0x00-0x3F) |

***Zoom and Focus Data:**

CAM_Zoom: Range (0x000-0xA23/0xA73), HD22: 0xA23(22x Zoom), HD30: 0xA73(30x Zoom)
 CAM_Focus: Range (0x000-0x438) dependent on Zoom Position

HD-22/30 Command List (2/2)

| Command Set | Command | Command Packet | Comments |
|-------------------|---------------------|---|--|
| CAM_Memory | Reset | 8x 01 04 3F 00 0p FF | |
| | Set | 8x 01 04 3F 01 0p FF | |
| | Recall | 8x 01 04 3F 02 0p FF | p:Memory No(=0-0xF) |
| CAM_IDWrite | | 8x 01 04 22 0p 0q 0r 0s FF | pqrs:0x0000 – 0xFFFF |
| CAM_LR_Reverse | On | 8x 01 04 61 02 FF | Mirror (Horizontal) on |
| | Off | 8x 01 04 61 03 FF | Mirror (Horizontal) off |
| CAM_Freeze | On | 8x 01 04 62 02 FF | Still image on |
| | Off | 8x 01 04 62 03 FF | |
| CAM_PictureEffect | Color | 8x 01 04 63 00 FF | |
| | B&W | 8x 01 04 63 04 FF | |
| Pan-tiltDrive | Up | 8x 01 06 01 VV WW 03 01 FF | VV: Pan Speed (0x01-0x18) |
| | Down | 8x 01 06 01 VV WW 03 02 FF | WW: Tilt Speed(0x01-0x14) |
| | Left | 8x 01 06 01 VV WW 01 03 FF | |
| | Right | 8x 01 06 01 VV WW 02 03 FF | |
| | UpLeft | 8x 01 06 01 VV WW 01 01 FF | |
| | UpRight | 8x 01 06 01 VV WW 02 01 FF | |
| | DownLeft | 8x 01 06 01 VV WW 01 02 FF | |
| | DownRight | 8x 01 06 01 VV WW 02 02 FF | |
| | Stop | 8x 01 06 01 VV WW 03 03 FF | |
| | Absolute Position | 8x 01 06 02 VV WW 0Y 0Y 0Y 0Y 0Z 0Z 0Z 0Z FF | YYYY: Pan Position** ZZZZ: Tilt Position** |
| | Home | 8x 01 06 04 FF | |
| Reset | 8x 01 06 05 FF | | |
| Tally | On | 8x 01 7E 01 0A 00 02 FF | |
| | Off | 8x 01 7E 01 0A 00 03 FF | |
| Preset Pan Speed | Pan/Tilt/Zoom Speed | 8x 01 7E 01 0B WW SS ZZ FF | WW: Pan Speed (0x01-0x18) SS:Tilt Speed(0x01-0x14) ZZ:Zoom Speed(0-7); |
| Motor Config | Hard Motor Stops | 8x 01 7E 01 70 00 00 FF | |
| | Soft Motor Stops | 8x 01 7E 01 70 00 01 FF | |
| BLK.Enhance | Pedestal | 8x 01 7E 53 00 00 0p 0q FF | Pq: Pedestal(0x00-0xFF) |
| GMA.Enhance | Gamma | 8x 01 7E 54 00 00 0p 0q FF | pq: Gamma (0x00-0x03) |
| CRM.Enhance | Chroma | 8x 01 7E 55 00 00 0p 0q FF | pq: Chroma (0x00-0xFF) |
| KNE.Enhance | Knee | No Support | No Support |
| DIS.Enhance | Digital Image | 8x 01 7E 57 02 FF | On |
| | Stabilizer | 8x 01 7E 57 03 FF | Off |
| DNR.Enhance | Digital Noise | 8x 01 7E 58 02 FF | On |
| | Reduction | 8x 01 7E 58 03 FF | Off |
| AGC.Enhance | AGC Mode | 8x 01 7E 59 00 FF | Off Manual AGC Gain (0dB) |
| | | 8x 01 7E 59 01 FF | Low |
| | | 8x 01 7E 59 02 FF | Medium |
| | | 8x 01 7E 59 03 FF | High |
| | | 8x 01 7E 59 04 FF | Low1 |
| | | 8x 01 7E 59 05 FF | Low2 |
| | | 8x 01 7E 59 06 FF | Med1 |
| | | 8x 01 7E 59 07 FF | High1 |
| | | 8x 01 7E 59 00 0p FF | Off p: Manual AGC Gain(1-0x0e)*** |
| CAM_Shutter | No Support | No Support | No Support |
| CAM_ICR | ICR Off | 8x 01 04 01 02 FF | ICR Off Color |
| | ICR On | 8x 01 04 01 03 FF | ICR On Black and White |

**** Additional Information:**

Pan Range: 8044 – 7FBC (-32,700 to +32,700)

Tilt Range: E891 – 4C2B (-5,999 to +19,499)

Actual Pan/Tilt ranges defined in Inquiry list

HD-22/30 Inquiry List (1/1)

| Inquiry Command | Command | Response Packet | Comments |
|-----------------------|-------------------|--|---|
| CAM_PowerInq | 8x 09 04 00 FF | y0 50 02 FF y0 50 03 FF | On Off(Standby) |
| CAM_ICRModelInq | 8x 09 04 01 FF | y0 50 02 FF y0 50 03 FF | On - ICR filter Out Off – ICR filter In |
| CAM_BacklightModelInq | 8x 09 04 33 FF | y0 50 02 FF y0 50 03 FF | On Off |
| CAM_WBModelInq | 81 09 04 35 FF | y0 50 00 FF y0 50 01 FF y0 50 02 FF y0 50 03 FF y0 50 05 FF y0 50 06 FF | Auto Indoor Outdoor One Push WB Manual Fluorescent |
| CAM_AEModelInq | 8x 09 04 39 FF | y0 50 00 FF y0 50 03 FF | Auto Exposure Mode Manual Control Mode |
| CAM_LR_Reverse | 8x 09 04 61 FF | y0 50 02 FF y0 50 03 FF | On Off |
| CAM_Freeze | 8x 09 04 62 FF | y0 50 02 FF y0 50 03 FF | On Off |
| CAM_PictureEffect | 8x 01 04 63 FF | y0 50 00 FF y0 50 04 FF | Off B&W |
| CAM_MemoryInq | 8x 09 04 3F FF | y0 50 0p FF | p: Preset 0-0xf |
| CAM_IDInq | 8x 09 04 22 FF | y0 50 0p 0q 0r 0s FF | pqr: 0x0000 – 0xFFFF |
| CAM_ApertureInq | 8x 09 04 42 FF | y0 50 00 00 0p 0q FF | Pq: x00-0x3F |
| CAM_RGain | 8x 09 04 43 FF | y0 50 00 00 0p 0q FF | pq: 000-Off |
| CAM_BGain | 8x 09 04 44 FF | y0 50 00 00 0p 0q FF | pq: 000-Off |
| CAM_ZoomPosInq | 8x 09 04 47 FF | y0 50 0p 0q 0r 0s FF | pqr: 0-0x6B3 |
| CAM_FocusPosInq | 8x 09 04 48 FF | y0 50 0p 0q 0r 0s FF | pqrs: Focus Position |
| CAM_FocusModelInq | 8x 09 04 38 FF | y0 50 02 FF y0 50 03 FF | Auto Manual |
| CAM_Gain | 8x 09 04 4C FF | y0 50 00 00 0p 0q FF | pq(0x00-0x24) |
| CAM_IRReceivelInq | 8x 09 06 08 FF | y0 50 02 FF y0 50 03 FF | On Off |
| Pan-TiltMaxSpeedInq | 8x 09 06 11 FF | y0 50 pp qq FF | pp: Pan 0x01-0x18 qq: Tilt 0x01-0x14 |
| Pan-tiltPositionInq | 8x 09 06 12 FF | FF y0 50 0p 0p 0p 0p 0q 0q 0q 0q FF | pppp: Pan 0x8044-0x7FB2 qqqq: Tilt 0xE890-0x4C2C |
| CAM_ShutterPosInq | No support | No support | Shutter Position |
| TallyInq | 8x 09 7E 01 0A FF | y0 50 02 FF y0 50 03 FF | On Off |
| PresetSpeedInq | 8x 09 7E 01 0B FF | y0 50 pp qq rr FF | pp: Pan 0x01-0x18 qq: Tilt 0x01-0x14 rr: Zoom 0x00-0x07 |
| Motor Config | 8x 09 7E 01 70 FF | y0 50 00 FF y0 50 01 FF | Hard Motor Stops Soft Motor Stops |
| BLK.Enhance | 8x 09 7E 53 FF | y0 50 00 00 0p 0q FF | pq: Pedestal(0x00-0xFF) |
| GMA.Enhance | 8x 09 7E 54 FF | y0 50 00 00 00 0p FF | p: Gamma (0x00-0x03) |
| CRM.Enhance | 8x 09 7E 55 FF | y0 50 00 00 0p 0q FF | p: Chroma (0x00-0xFF) |
| KNE.Enhance | No support | No Support | Knee |
| DIS.Enhance | 8x 09 7E 57 FF | y0 50 02 FF y0 50 03 FF | On Off |
| DNR.Enhance | 8x 09 7E 58 FF | y0 50 02 FF y0 50 03 FF | On Off |
| AGC.Enhance | 8x 09 7E 59 FF | y0 50 00 FF y0 50 01 FF y0 50 02 FF y0 50 03 FF y0 50 04 FF y0 50 05 FF y0 50 06 FF y0 50 07 FF 8x 09 7E 59 00 FF y0 50 0p FF | Off Manual AGC Gain(0dB) Low Medium High Low1 Low2 Med1 High1 Off p: Manual AGC Gain(0-0x0e)*** |

***Manual AGC Gain: 0:0dB, 1:3dB, 2:6dB, 3:9dB, 4:12dB, 5:15dB, 6:18dB, 7:21dB, 8:24dB, 9:27dB, 10:30dB, 11:33dB, 12:36dB, 13:39dB & 14:42dB



Inside Back Cover - Blank



Toll Free: 800-572-2011 ▪ Phone: 763-971-4400 ▪ FAX: 763-971-4464

www.vaddio.com

©2015 Vaddio - All Rights Reserved. Reproduction in whole or in part without written permission is prohibited. Specifications and pricing are subject to change without notice. Vaddio, Quick-Connect, ProductionVIEW, HSDS, EZIM, CONCEAL and PowerVIEW are trademarks of Vaddio. All other trademarks are property of their respective owners. Document 342-0645 Rev F, SD: 68670.0