

## eDIN DEMULTIPLEXER (DMX TO ANALOG INTERFACE)

# #1004



## PRODUCT OVERVIEW

The eDIN #1004 converts DMX512 to 16 channels of analog DC output voltage. Diode shunts allow user-selection between current sourcing applications—typically for theatrical dimmers—or current-sinking control—typically for LED fixture drivers or Mark VII electronic fluorescent ballast control. A non-dim mode supports solid-state relay control.

## FEATURES

- DMX512 start address and operating mode may be set from front panel interface or remotely using E1.20 RDM
- Indicator LEDs for power, processor, and DMX input status
- Standard DC output modes of 0-10V, 0-15V, 0-2.5V, or 0-5V
- Custom mode allows user-set minimum and maximum DC output up to 16V
- EFBC/LED Driver mode allows single DMX channel control of mains voltage (via SSR) and 0-10V dimming
- Maximum current rating per output of 10mA (sourcing) or 30mA (sinking)
- CCL “Panic Input” drives all outputs to full
- Pluggable terminal block connections accept solid or stranded wire between #26 and #16 AWG
- One DMX512-A/RDM data input connection
- One passive DMX512-A data through connection
- Data and power easily daisy-chained between modules
- Termination switch
- Firmware field-upgradable using RDM (requires Pathway Pathport node and RDM utility program)

## SPECIFICATIONS

- 1500V opto-isolation between input and output ports
- 250V fault protection on input and output ports
- Input operating voltage: 9-30 VDC
- 6W power consumption
- Operating conditions: -10°-50°C; 10-90% relative humidity, non-condensing

### STANDARDS COMPLIANCE

- ANSI E1.11 DMX512-A(2008)/USITT DMX512(1990)
- ANSI E1.20 RDM(2010) - Remote Device Management
- ANSI E1.3 0-10V Analog Control (with diodes shunts on)
- ANSI C82.11 Fluorescent Ballast Control (diode shunts off)
- CE/FCC
- RoHS 2002/95/EC
- Class 2 Low Voltage

### WEIGHTS AND DIMENSIONS

- 0.70 lbs (0.316 kg)
- 3.6”W x 6.25”L x 1.5”H (91mm x 160mm x 38mm)

### INCLUDED FURNISHINGS

- DIN tray (housing) with end caps
- 12” (300mm) x 35mm DIN rail
- Installation/Operations manual

## OPERATING MODES

- **Mode 1 : 0-10VDC Output**
- **Mode 2 : 0-5VDC Output**
- **Mode 3 : 0-15VDC Output**
- **Mode 4 : 0-2.5VDC Output**
- **Mode 5 : Custom Output:** The user may set both a minimum output voltage and a maximum output voltage. Valid DC voltage output range is 0VDC to 16VDC. Values are set as an 8-bit number (0-255). Valid minimum levels are between 0 and 254. Valid maximum levels are between 1 and 255. For example, a value of 158 is equal to an output of 10V. Custom values are not maintained in other operating modes, and do not apply to modes 6, 7 and 8.
- **Mode 6 : Electronic Fluorescent Ballast/LED Driver Control—10% Threshold:** Outputs are paired (1 and 9, 2 and 10, etc.) for unified control of up to eight circuits of LED fixture drivers or Mark VII-type fluorescent ballast controllers. A single DMX channel controls the 0-10V of the lower output, while causing the higher output to provide on/off control of a solid state relay as the DMX value increases or decreases through the threshold. A 12VDC power supply is required.
- **Mode 7 : Non-Dim :** Provides on/off control of solid state relays. At a DMX value of 0%, an output will produce 10V. When the DMX value crosses 50%, the output voltage drops to 0V. Blocking diodes must be shunted (switches in the off position). A 12VDC power supply is required.
- **Mode 8 Electronic fluorescent Ballast/LED Driver Control—1% Threshold:** Outputs are paired (1 and 9, 2 and 10, etc.) for unified control of up to eight circuits of LED fixture drivers or Mark VII-type fluorescent ballast controllers. A single DMX channel controls the 0-10V of the lower output, while causing the higher output to provide on/off control of a solid state relay as the DMX value increases or decreases through the threshold. A 12VDC power supply is required.

## APPLICATION RISER

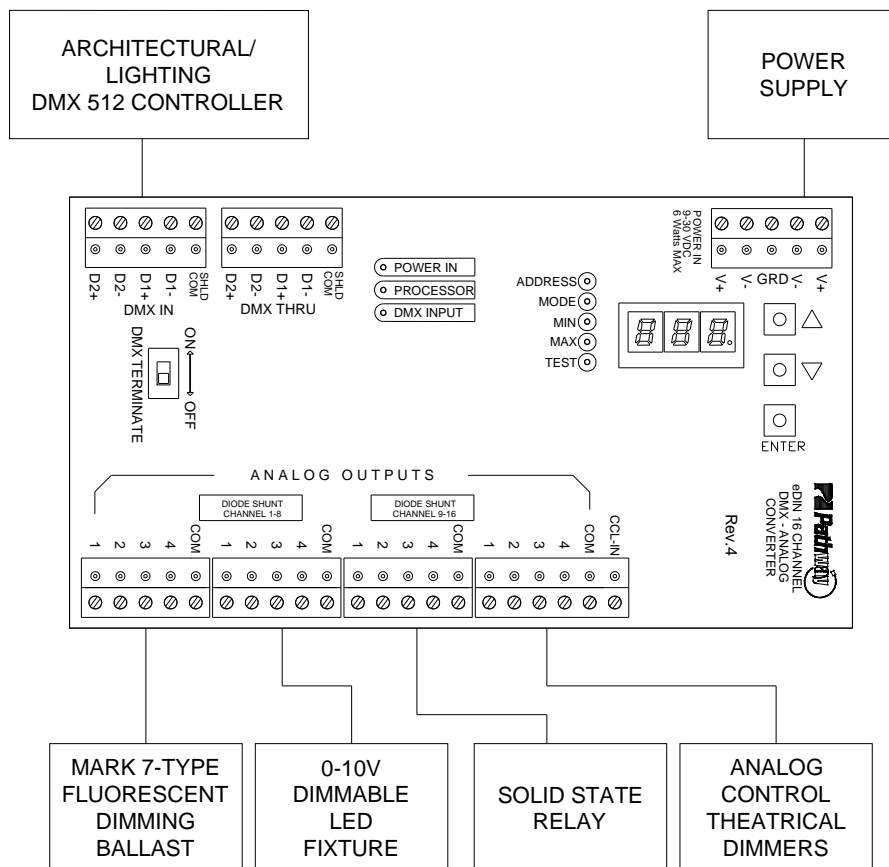

## ELECTRONIC FLUORESCENT BALLAST CONTRL/LED DRIVER WIRING RISER

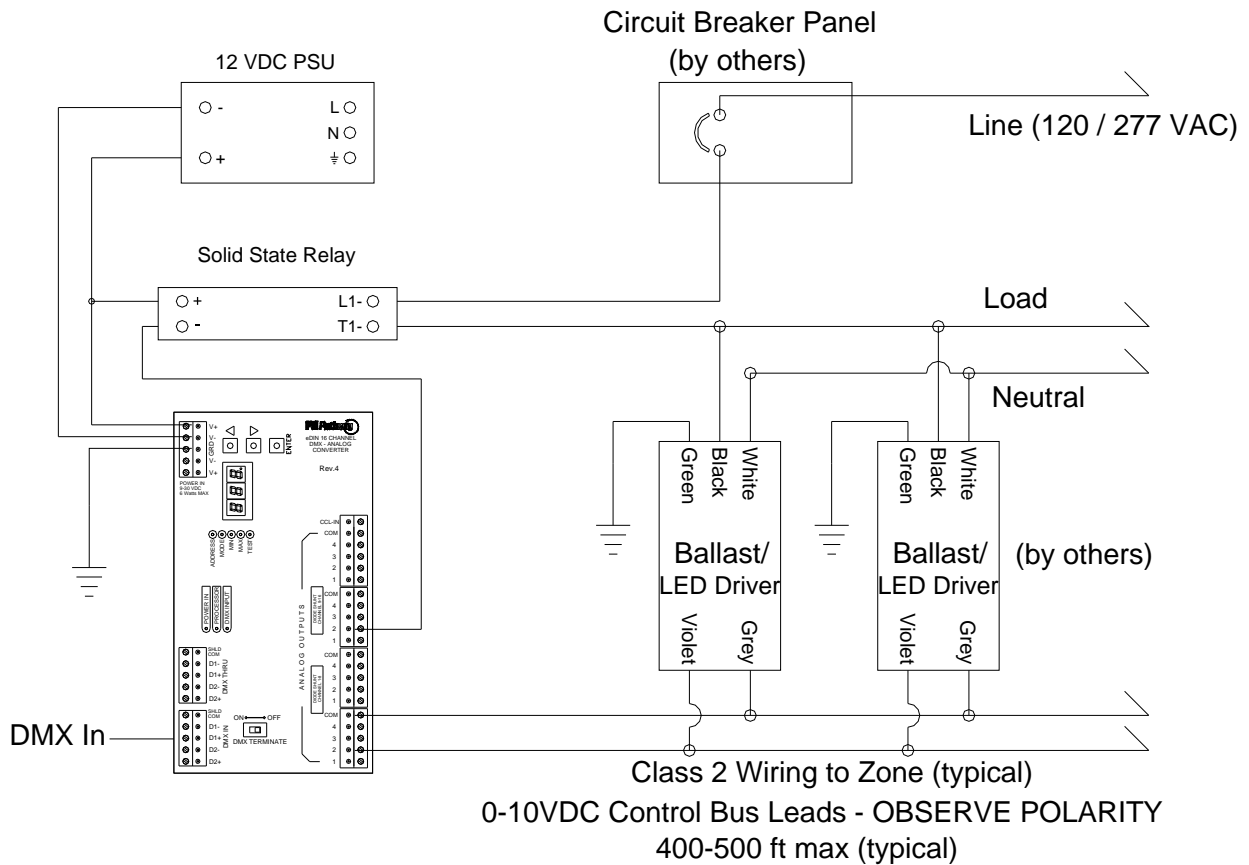

### DMX512/RDM PIN OUT:

XLR PIN #	PURPOSE
1	Shield
2	Data - (complement)
3	Data + (true)
4	Data - (pair 2 complement)
5	Data + (pair 2 true)

### ORDERING INFORMATION

PART #	DESCRIPTION
1004	eDIN Demultiplexer, 16 Channel
ACCESSORIES	
1001-30	24VDC - 30W DIN-mountable Power Supply
1103	Rack-mount Panel Kit (2RU) with two 16.5" (420mm) sections of DIN rail
1105	Small eDIN Enclosure (NEMA1) with 9.5" (240mm) of vertical DIN rail
1106	Large eDIN Enclosure (NEMA1) with 19.5" (495mm) of vertical DIN rail
1107	Large eDIN Enclosure (NEMA1) with three rows of 9.5" (240mm) horizontal DIN rail
4000	eDIN Enclosure Assembly Service