



PDS-60ca

Power / data supply for indoor and outdoor applications

PHILIPS

PDS-60ca

Power / data supply for indoor and outdoor applications

PDS-60ca is a versatile power / data supply designed for indoor and outdoor LED lighting fixtures employing low voltage fixtures from Philips Color Kinetics.

- PDS-60ca is available in 7.5 V and 24 V versions to meet the power requirements of a variety of fixtures. Both 7.5 V and 24 V versions communicate control data via Ethernet and DMX networks, allowing for compatibility with the full range of Philips Color Kinetics and third-party controllers.
- Features a NEMA 4 (IP66) enclosure, PDS-60ca installs in dry, damp, and wet locations.
- Accommodates input voltages ranging from 100 VAC to 240 VAC. Short circuit protection prevents device failure due to incorrectly wired fixtures.
- PDS-60ca is available in a pre-programmed version, which features built-in visual effects and allows for light show configuration without controllers.
- Offers multiple standard-size conduit entries to accommodate 1/2 in and 3/4 in US trade-sized conduit.
- PDS-60ca Pre-Programmed functions as a master controller, delivering data to the other power / data supplies in the run. Use one PDS-60ca Pre-Programmed unit per run, and standard additional power / data supplies. A downstream power / data supply does not have to be a PDS-60ca, but can be any DMX- or Ethernet-based power / data supply.
- Instead of attaching fixtures to a Pre-Programmed PDS-60ca, you could use it as an outdoor-rated light show controller for DMX- or Ethernet-based power / data supplies and their fixtures.

Compatible Fixtures

Device	Fixture	Max. Quantity Per Device
PDS-60ca 7.5 V	iColor Flex MX	120 nodes
	eW Flex Micro	120 nodes
PDS-60ca 24 V	eW Flex Compact	60 nodes
	iColor Flex LMX	60 nodes
	iColor Cove EC 7 in	30 fixtures
	iColor Cove EC 12 in	30 fixtures
	iColor Cove QLX 6 in	30 fixtures
	iColor Cove QLX 12 in	20 fixtures

Versions and Features

Version	Features
PDS-60ca 7.5 V DMX / Ethernet	Compatible with both DMX and Ethernet networks. On-board indicators show the status of the data connection.
PDS-60ca 24 V DMX / Ethernet	
PDS-60ca 7.5 V Pre-Programmed	Has configurable, on-board effects. Cannot receive controller data, but can send data to downstream power / data supplies and connected fixtures.
PDS-60ca 24 V Pre-Programmed	



Versatile power / data supply for indoor and outdoor applications

The device's NEMA 4 (IP66) enclosure allows for installation in dry, damp, and wet locations.

Specifications

Due to continuous improvements and innovations, specifications may change without notice.

Item	Specification	Details	
Electrical	Input Voltage	100 – 240 VAC, auto-switching, 50 – 60 Hz	
	Maximum Input Current	1.7 A at 100 VAC, 1.5 A at 120 VAC, .75 A at 240 VAC	
	Power Output	PDS-60ca 7.5 V	7.5 VDC, 60 W maximum
		PDS-60ca 24 V	24 VDC, 60 W maximum
	Fuse Rating	PDS-60ca 7.5 V	(2) 5 A, 5 x 20 slow blow fuses
PDS-60ca 24 V		(2) 4 A, 5 x 20 slow blow fuses	
Physical	Dimensions (Height x Width x Depth)	3.6 x 5.5 x 8.8 in (91 x 140 x 224 mm)	
	Weight	4.5 lb (2.0 kg)	
	Construction	Cast aluminum enclosure with gray powder-coated finish	
	Connectors	Data	RJ45 input and output connectors
		Power Output	(2) 4-pin output receptacles
		Power Input	Line-neutral-ground cable, flying leads
	Temperature Ranges	14° – 104° F (-10° – 40° C) Operating	
		14° – 122° F (-10° – 50° C) Startup -40° – 176° F (-40° – 80° C) Storage	
	Humidity	0 – 95%, non-condensing	
	Cooling	Convection	
Heat Dissipation	25% of total power input at maximum load		
Data Input Source	PDS-60ca 7.5 V DMX / Ethernet	Philips full range of controllers, third-party DMX controllers, or KiNET-compatible* third-party Ethernet controllers	
	PDS-60ca 24 V DMX / Ethernet		
	PDS-60ca 7.5 V Pre-Programmed	Internal	
	PDS-60ca 24 V Pre-Programmed		
Certification and Safety	Certification	UL / cUL, CE, PSE	
	Classification	UL Class 2 power supply	
	Environment	Dry / Damp / Wet Location, IP66	

* KiNET is the Ethernet lighting protocol from Philips Color Kinetics.



Ordering Information

Item	Item Number	Philips 12NC
PDS-60ca 7.5 V DMX / Ethernet	109-000015-03	910503700094
PDS-60ca 7.5 V Pre-Programmed	109-000015-00	910503700093
PDS-60ca 24 V DMX / Ethernet	109-000016-04	912400133526
PDS-60ca 24 V Pre-Programmed	109-000016-00	910503700095

Use Item Number when ordering in North America.

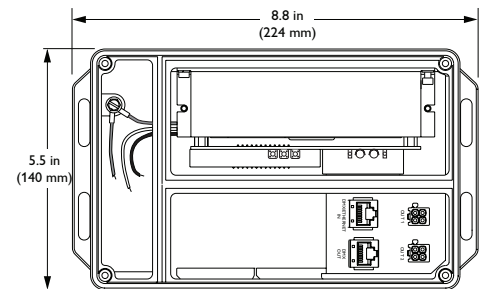
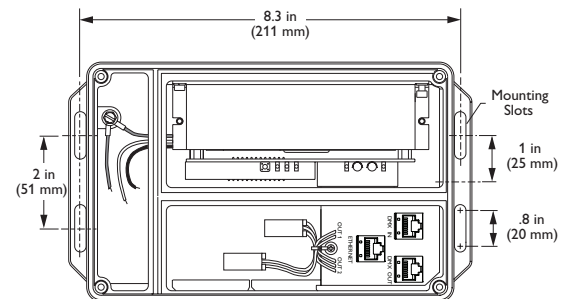
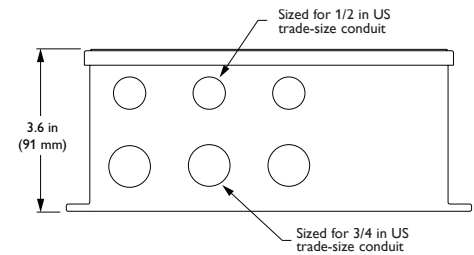
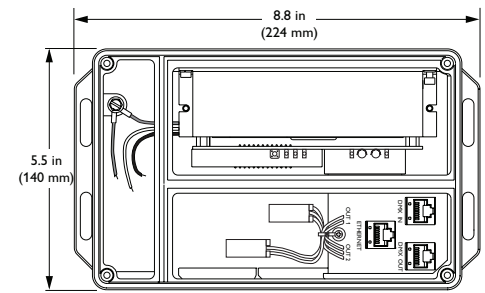

Included in the box

- PDS-60ca power / data supply
- (2) White clamp-on EMI suppression cores
- Black clamp-on EMI suppression core
- (2) Spare fuses
- (4) Sealing plugs and rings 1/2 NPT
- (4) Sealing plugs and rings 3/4 NPT

Installation

PDS-60ca is a power / data supply designed for low-voltage linear DMX and Ethernet lighting installations. PDS-60ca provides power and data to up to 30 low-voltage fixtures from Philips Color Kinetics and delivers 60 watts of low-voltage output via two ports. It features a NEMA 4 (IP66) enclosure, and can be installed in dry, damp, and wet locations. It automatically accommodates input voltages ranging from 100 VAC to 240 VAC.

Owner / User Responsibilities

It is the responsibility of the contractor, installer, purchaser, owner, and user to install, maintain, and operate PDS-60ca in such a manner as to comply with all applicable codes, state and local laws, ordinances, and regulations. Consult with the appropriate electrical inspector to ensure compliance.

Plan the Installation

To streamline installation and ensure accurate configuration, start with a layout or a lighting design plan that shows the physical layout of the installation and identifies the locations of all lighting fixtures, power / data supplies, controllers, switches, and cables.

DMX, Ethernet, and Pre-Programmed Configurations

PDS-60ca DMX / Ethernet can be used in either DMX or Ethernet networks. Pre-Programmed versions cannot receive controller data, but can send light show data to DMX or Ethernet power / data supplies using the pre-programmed device's OUT port.

DMX is appropriate for relatively simple installations, or for installations in which groups of lights operate in unison (for example, for accent lighting, perimeter lighting, or cove lighting applications). Typical DMX installations with fixtures from Philips Color Kinetics use a controller such as iPlayer 3, a Controller Keypad for turning lights on and off and triggering light shows, and one or more PDS-60ca devices. PDS-60ca devices can be connected in series to deliver DMX data from a single controller to all connected lights. Note that the maximum for DMX data run lengths is 1000 ft (305 m).

Because it is not subject to the DMX addressing limitations, Ethernet is the preferred environment for large-scale, color-changing light shows and video displays, both of which require large numbers of unique addresses.

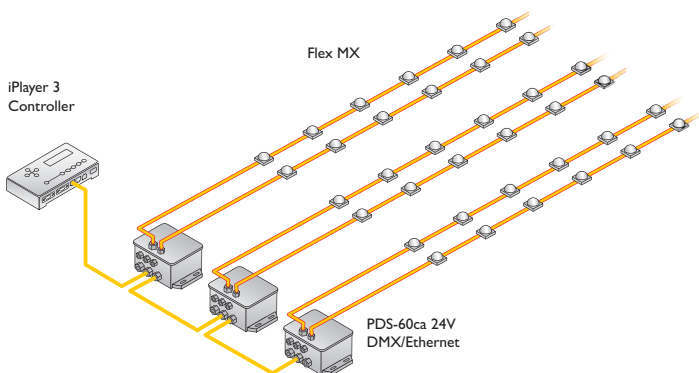

☛ Refer to the PDS-60ca Installation Instructions for specific warning and caution statements.

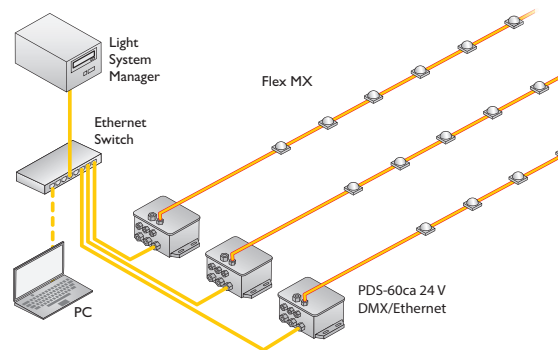

Pre-Programmed Installation

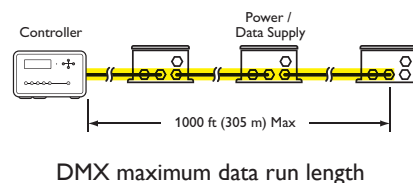

Typical Ethernet installations with LED lighting fixtures from Philips Color Kinetics use an Ethernet switch, an Ethernet controller (such as Light System Manager, ColorDial Pro or Video System Manager Pro), one or more Ethernet Controller Keypads (for light show triggering), and one or more PDS-60ca devices. For additional devices in a network, use additional Ethernet switch ports.

In an Ethernet environment, each Philips Color Kinetics power / data supply has a unique IP address. Each fixture connected to the device is automatically assigned unique identifiers that controllers use to identify and manage each fixture.

Maximum data cable lengths are 328 ft (100 m) between Ethernet devices without a repeater.

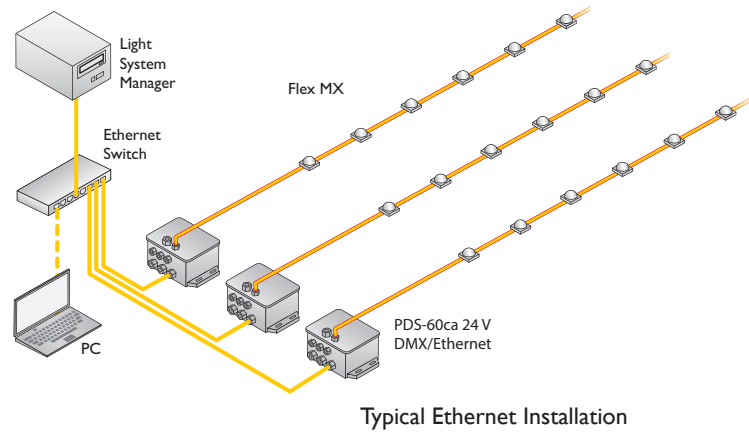
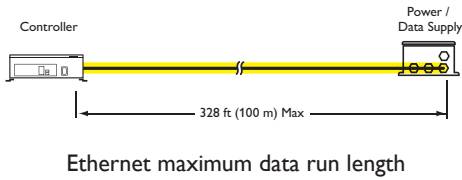

Electrical Configuration Guidelines

The number of fixtures that each PDS-60ca unit can support depends on the power requirements of the specific fixtures that you are using. Refer to the table on the left for quantities of each fixture that you can connect per PDS-60ca device. Refer to the fixture product guides for information on electrical configuration for fixtures.

When installing in damp or wet locations, seal all points of possible moisture ingress with electronics-grade RTV silicone sealant so that water or moisture cannot enter or accumulate.

Included in the box

PDS-60ca power / data supply
(2) White clamp-on EMI suppression cores
Black clamp-on EMI suppression core
(2) Spare fuses
(4) Sealing plugs and rings 1/2 NPT
(4) Sealing plugs and rings 3/4 NPT

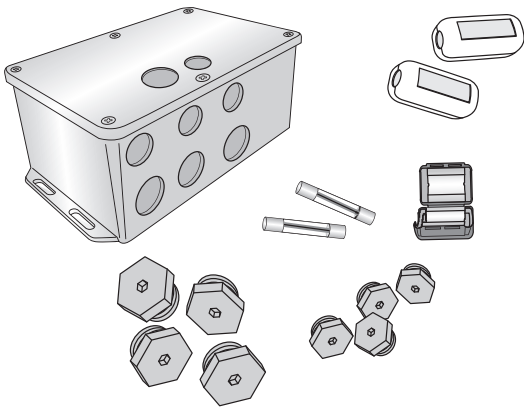

Inspect PDS-60ca and Accessories

Carefully inspect the box containing the PDS-60ca and the contents for any damage.

Assemble Additional Items

The following items are required to mount and connect the PDS-60ca:

- 3-conductor copper wire for power connections, as required. Standard 12 AWG (3.31 mm²) stranded wire is recommended.
- Three wire connectors
- CAT 5e or better data cable, as required
- The included black magnetic EMI suppression core (for the power cable)
- The included two white magnetic EMI suppression cores (for iColor Flex / eW Flex strands or fixture leader cables)
- Power screwdriver (for mounting)
- Four screws suitable for the mounting surface
- Phillips screwdriver
- 8 mm hex wrench or adjustable wrench
- The included four 1/2 and 3/4 NPT sealing plugs and rings
- Electronics-grade RTV silicone for installations in damp and wet locations
- Cable strain relief and other connectors as needed
- Water-tight conduit, connectors or fittings (as required by installation and local codes)
- Wire strippers and other tools as needed

Mount the PDS-60ca

Make sure line power is OFF before mounting and connecting. A power screwdriver is recommended.

1. Position the PDS-60ca device in its designated mounting location. Make sure the mounting location is flat, suitable for the mounting hardware, and clear of debris and other obstructions.
2. Using four screws suitable for the mounting surface, secure the PDS-60ca device to the surface using the two mounting slots located at both ends of the device.

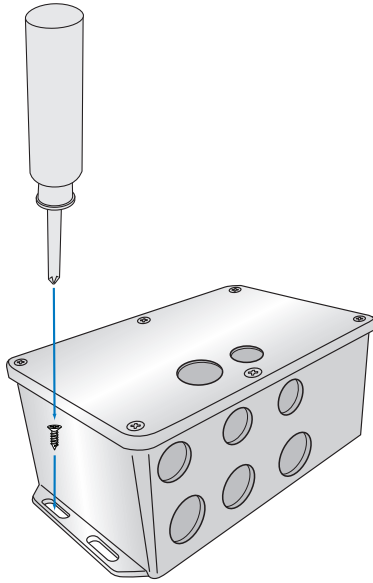

✳ Make sure that there is adequate space to make all connections to the top and side of the device.

✳ Make sure that the device is securely attached and free of excessive vibration.

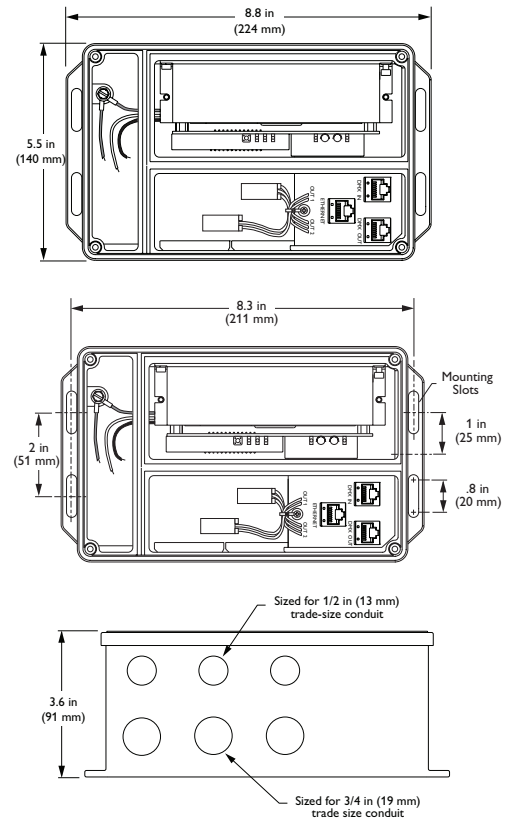

Install EMI Suppression Cores

The PDS-60ca arrives packaged with three EMI suppression cores. These suppression cores reduce electromagnetic noise that can interfere with other electrical equipment. The white suppression cores are for iColor and eW Flex strands or fixture leader cables. The black suppression core is for the power cable.

Before attaching the cores, make sure that each set of ferrite metal halves are secure in their plastic housing.

1. Attach the black suppression core to the power cable:
 - Near the end of the cable that connects to the power / data supply, coil the power cable into a small loop.
 - Place the section of the loop where the cord is doubled into the suppression core. Be sure the cord is securely in the core's middle.
 - Snap the core shut around the doubled cord.
2. Attach a white suppression core to the fixture strand or leader cable attached to port 1.
 - Near the connection to the power / data supply, coil the strand or cable into a small loop.
 - Place the section of the loop where the cord is doubled into the suppression core. Be sure the cord is securely in the core's middle.
 - Snap the core shut.
3. Repeat step 2 for the second white suppression core, if necessary.

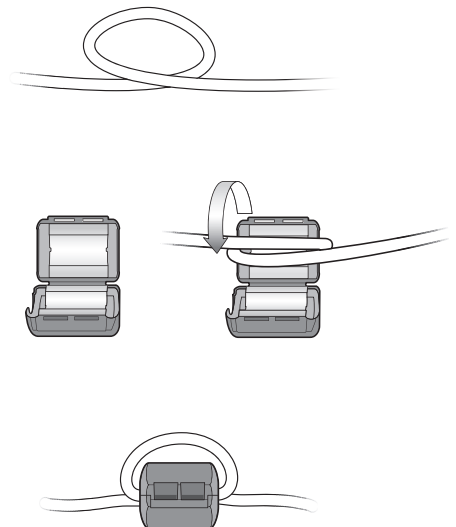

Prepare Cable Connections

1. Using a Philips screwdriver, loosen the housing cover's six screws to open the PDS-60ca housing.
2. Identify which openings to use for power and data cables, and using an 8 mm hex wrench or adjustable wrench, place the included sealing plugs and rings in the unused openings. Make sure that the sealing rings are seated correctly. Use RTV silicone if installing in damp or wet locations.
3. Torque the sealing plugs to approximately 19 in-lb (2.2 Nm).

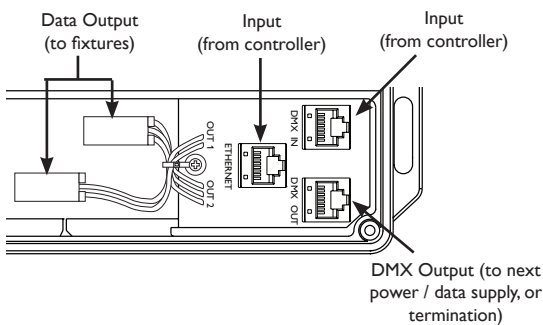
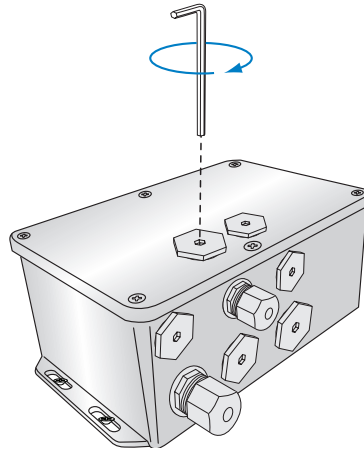

7.5V and 24V PDS-60ca DMX / Ethernet Ports

4. Install and tighten cable connectors or conduit to manufacturer's specs in the remaining openings. Do not overtighten.
 - For installations using US trade size conduit, the larger openings accommodate 3/4 in NPT cable connectors for power, and the smaller openings accommodate 1/2 in NPT cable connectors for data.

Make Data Input Connections

PDS-60ca has different layouts for data connection ports, depending on the version you have. See the illustrations on the left as a guide to the port locations in the connection chamber.

The PDS-60ca listens for data on both the DMX and Ethernet input ports. When valid data is detected, PDS-60ca automatically switches to the appropriate mode.

Since pre-programmed devices do not accept controller data, you will not be able to use the DMX IN port on these devices. However, you can use the device's DMX OUT port to link to downstream power / data supplies, which can receive light show data.

DMX

1. Using an RJ45 connector cable, connect your controller's DMX output port to the DMX IN port on the PDS-60ca.
2. To add a second power / data supply to your DMX network, connect an RJ45 cable from the PDS-60ca device's DMX OUT port to the DMX IN port on the second PDS-60ca device.
3. If necessary, continue connecting PDS-60ca devices (up to 32 without a repeater).

Ethernet

- Using a CAT 5 cable, connect the ETHERNET IN port on the PDS-60ca to an available port on an Ethernet switch connected to your lighting network.

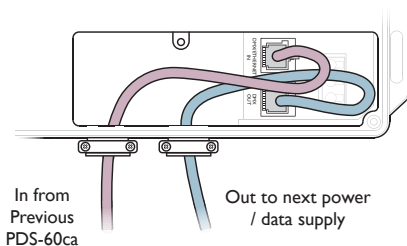

Connecting Pre Programmed and power / data supplies

Connect Fixtures to PDS-60ca

Make sure line power is OFF before connecting fixtures to the device. On most PDS-60ca models, the fixture ports are at the end of a short cable attached to the board adjacent to device's data ports. (See the illustrations on the previous page.)

1. Guide the connector and cable through an opening in the device's fixture connection chamber.
2. Connect a iColor / eW Flex strand or fixture leader cable to one of the two available ports in the device's power connection chamber.

Connect the PDS-60ca to Line Power

The device arrives with line, neutral, and ground wires in the form of flying leads ready for connection in the power connection chamber. You connect line power to the leads by using wire connectors.

1. Install a cable strain relief connector in one of the device's 3/4 in openings in the power connection chamber. If necessary, use conduit as required by local electrical codes.
2. Run the mains line power cable through the opening. Pull at least 6 in (152 mm) of wire into the chamber.
3. Strip at least .38 in (10 mm) of insulation from the wires. Join the mains line power cable with the flying leads using three wire connectors.

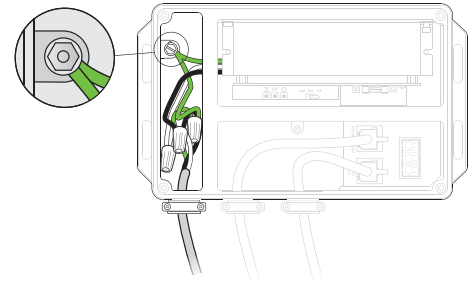

PDS-60ca connected to mains line power

Display Light Effects (Pre-Programmed Only)

If you have the pre-programmed version of the PDS-60ca, you are able to display effects on your fixtures without a controller. Pre-programmed controllers cannot receive signals from external controllers. But they *can* send light show data to other downstream devices via the DMX OUT port, thereby effectively playing the role of a controller. (Refer to the Make Data Input Connections section for instructions on how to link other power / data supplies via DMX OUT ports.)

To achieve the effects you want, you can use the controls inside the device, which consists of a toggle switch and three buttons. Once you have set the mode, speed, and options for effects using the control button, PDS-60ca stores settings and records them, even after you have cycled the power on the device.

To display effects:

1. With the PDS-60ca cover removed and the power off, use the toggle switch inside the housing to select the type of fixtures that are attached to the device. (See the fixture type switch settings table on the right.)
2. Power the device on. (For chasing comet shows, hold down the MODE button during power up to run a blink scan of attached nodes to determine the run length.)
3. Use the Mode button to select an effect. Press and release the Mode button to cycle through each effect described in the Lighting Effects Settings table on the next page.
4. If desired, use the Options button to modify the effect you chose with the mode button.
5. Use the Speed button to change the speed of the effect. Hold down the Speed button to change the color for the Fixed Color effect.

Effect setting changes are immediate.

***** Before connecting to line power, set the fixture type using the toggle switch. If the fixture type is changed after power is engaged, the power supply must be powered off and turned back on to recognize the toggle switch change.

Fixture Type Toggle Switch Settings

Position	Setting	Fixtures
1	Linear RGB Effects	iColor Flex MX, iColor Flex LMX, iColor Cove EC, iColor Cove QLX
2	Tile Effects	iColor Tile FX
3	Monochromatic Effects	Best used with eW Flex

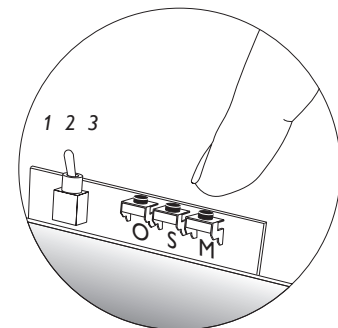

Effects buttons and toggle switch

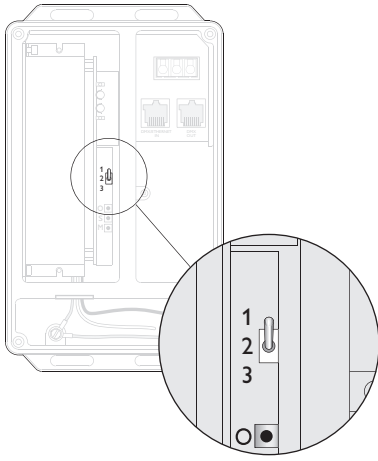

Effects toggle switch

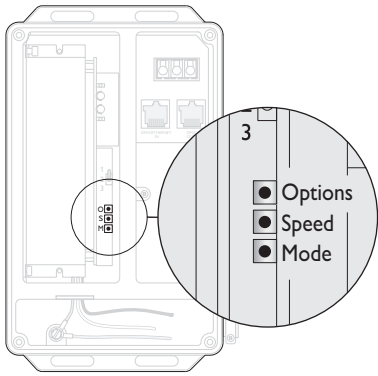

















Effects buttons

PDS-60ca Pre-Programmed has four controls that are located inside the device's housing:

- The toggle switch selects the fixture type.
- The lowest button (farthest from the toggle switch) sets the Mode, which cycles through different available effects
- The middle button sets the Speed for most effects, and sets the color for Fixed Color effects (hold the button down to cycle through the color spectrum)
- The highest button (nearest to the toggle switch) sets the Options, which cycles through effect properties

Light Effect Settings (Pre-Programmed Only)

Switch Position	Mode Button	Description	Speed Button	Options Button	
1 Linear RGB Effects (iColor Flex MX, iColor Flex LMX, iColor Cove EC, iColor Cove QLX fixtures)	1. Rainbow 	Produces a smooth transition through the color spectrum. Colors appear to follow each other from fixture to fixture	Cycles through four effect speed settings	Cycles through four width settings, then reverses direction and decreases widths	
	2. Random 	Produces a sequence of randomly generated solid colors simultaneously on all fixtures		Toggles between immediate and fade changes	
	3. Colorwash 	Produces a smooth hue transition on all fixtures simultaneously, progressing through the color spectrum		Reverses effect direction	
	4. Fixed Color 	A static display of one solid color, with a configured color and intensity level.	Press and hold the speed button to change the color	Not Applicable	
2 Tile Effects (iColor Tile MX)	1. Burst 	Produces circles of concentric color originating in the center and moving towards the outer edge of a group	Cycles through four effect speed settings	Reverses effect direction	
	2. Spiral 	The Spiral effect produces arcs of color originating in the center of a group and moving in a clockwise direction		Reverses effect direction	
	3. Vertical Rainbow 	Produces a smooth transition through the color spectrum. Colors appear to follow each other from node to node from the top to the bottom of the tile.		Cycles through four width settings then reverses direction and decreases widths	
	4. Horizontal Rainbow 	Produces a smooth transition through the color spectrum. Colors appear to follow each other from fixture to fixture from node to node from one side to the other.		Toggles between snap and fade changes	
	5. Random 	Produces a sequence of randomly generated solid colors simultaneously on all fixtures in a group		Reverses effect direction	
	6. Color Wash 	Produces a smooth hue transition on all fixtures simultaneously, progressing through the color spectrum		Press and hold the speed button to change the color	Not Applicable
	7. Fixed Color 	A static display of one solid color, with a configured color and intensity level.		Press and hold the speed button to change the color	Not Applicable
3 Monochromatic Effects (Best used with eW Flex)	1. Alternating On / Off 	A display of alternating on and off nodes, which appear to follow each other in a way similar to lights on a marquee	Cycles through four effect speed settings	Cycles through four width settings	
	2. White Chasing Comet 	Displays a band of light that appears to move across a dark background		Cycles through five distinct comet width settings	
	3. Dark Chasing Comet 	Displays a dark band that appears to move across a light background		Cycles through five distinct comet width settings	
	4. Random Sparkle 	Produces a series of light flashes at regular intervals on random nodes		Toggles between straight On / Off and dimmed sparkle	
	5. White Fixed Color 	A static display of solid white color		Not Applicable	Not Applicable

Addressing and Controlling Fixtures

Addressing methods differ depending on your network environment (DMX or Ethernet). In DMX networks, PDS-60ca devices use DMX addresses to communicate with connected fixture nodes. For color-changing fixtures, each node receives three sequential DMX addresses, one for the red channel, one for the green channel, and one for the blue channel. With PDS-60ca devices in a DMX network, fixtures are not directly programmed with DMX addresses. Instead, you use the device's Auto Config Button to discover connected nodes and use QuickPlay Pro software to program a base light number on the PDS-60ca. Discovery makes the PDS-60ca aware of its nodes so that it can assign addresses and send control data correctly. Discovered nodes are automatically addressed in reference to the base light number that you set.

A light number corresponds to three sequential DMX addresses. Since a DMX universe consists of 512 DMX addresses, there are 170 light numbers per universe ($170 \times 3 = 510$, with two DMX addresses left over). Light number 1 corresponds to DMX addresses 1, 2, and 3; light number 2 corresponds to DMX addresses 4, 5, and 6; light number 3 corresponds to DMX addresses 7, 8, and 9; and so on.

Ethernet is the preferred environment for installations requiring large numbers of individually controllable nodes, such as video displays and dynamic light shows with intricate effects. In Ethernet networks, each PDS-60ca device comes pre-programmed with a unique IP address, so it effectively functions as its own DMX universe. You can discover all PDS-60ca devices in an installation using QuickPlay Pro, which automatically determines how many fixtures are connected to each output port and addresses them. Light System Manager and Video System Manager Pro, Ethernet lighting controllers from Philips Color Kinetics also automatically discover and address all connected fixtures.

Pre-programmed PDS-60ca devices cannot receive input from controllers, but they can send light show data to other DMX devices connected to the pre-programmed device's DMX OUT ports. No address programming is required for a PDS-60ca pre-programmed device. Downstream PDS-60ca DMX devices will need to discover their connected nodes using the Auto Config button.

► To discover all connected nodes:

1. Make sure the power is ON before addressing fixtures.
2. Connect all fixtures that need to be addressed to the device's output ports.
3. Press the Auto Config Button inside the device's housing. The connected nodes flash. (In Ethernet networks, you cannot use the Auto Config button. Instead discover fixtures using controller software (for instance, QuickPlay Pro or the Node Count button in the PDS Configuration screen of ColorPlay Pro.)

In an Ethernet network, and in a PDS-60ca device downstream from a pre-programmed device, no further steps are necessary. All nodes now have the appropriate addresses. In a DMX network, you may need QuickPlay Pro software to assign a base light number to the PDS-60ca.

For complete details on addressing, and on using QuickPlay Pro, refer to the Addressing and Configuration Guide, available at www.colorkinetics.com/support/addressing/.

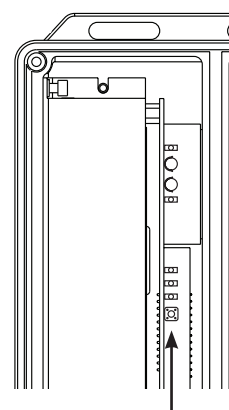

Auto Config Button

7.5 V & 24 V PDS-60ca DMX / Ethernet

Status Indicators

The PDS-60ca has several status indicators, depending on the network data mode (Ethernet or DMX) of the device. The indicators are located inside the fixture's housing.

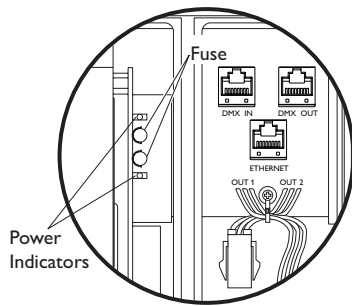

Power indicators

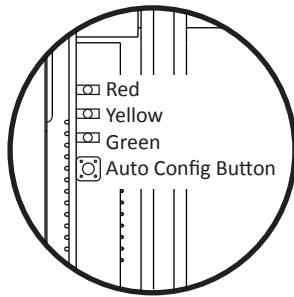

PDS-60ca Ethernet / DMX mode and status indicators

Power Indicators

The PDS-60ca has two power indicators, one for each fixture port. If a port fails for any reason (for instance, if a fuse blows), the red indicator light will be off.

Ethernet / DMX Mode and Status Indicators

The PDS-60ca power / data supply listens for data on both of the input ports. When a valid connection is detected, PDS-60ca switches to the appropriate mode. Three indicator lights show the mode (Ethernet or DMX) and if applicable, the status of the Ethernet connection.

PDS-60ca Ethernet / DMX Status Indicators

Color	Indicator	Mode	Meaning
Red	DMX / Ethernet Mode Status	Continuous Red	PDS-60ca is operating in DMX mode
		Blinking Red (once per second)	PDS-60ca is operating in Ethernet mode
Yellow	Ethernet Data Status	Flickering Yellow	Blinks for every Ethernet packet received
Green	Ethernet Link Status	Continuous Green	A valid Ethernet link is detected
		Off	No Ethernet link is detected

Securing the Cover and Sealing PDS-60ca

After all the power and data connections, addressing, and pre-programmed effects changes have been made, and you have made sure that all through holes are water-tight, you may seal the device.

1. Replace the cover, ensuring that the gasket is seated properly and that no wires are pinched.
2. Attach the cover with the six included screws. Tighten screws to 8 to 10 in-lbs (1 in-lb = 11.2985 N-cm). If you are installing in a wet or damp location, seal with RTV silicone.

Installing in Damp or Wet Locations

When installing in damp or wet locations, seal all junction boxes, power supplies, and other devices with electronics-grade RTV silicone sealant so that water or moisture cannot enter or accumulate in any wiring compartments, cables, fixtures, or other electrical parts. You must use suitable outdoor-rated junction boxes when installing in damp or wet locations. Additionally, you must use gaskets, clamps, and other parts required for installation to comply with all applicable local and national codes.

 In wet or damp locations, use electronics-grade RTV silicone to seal all points of entry in all PDS-60ca devices and all connected junction boxes to prevent water infiltration.

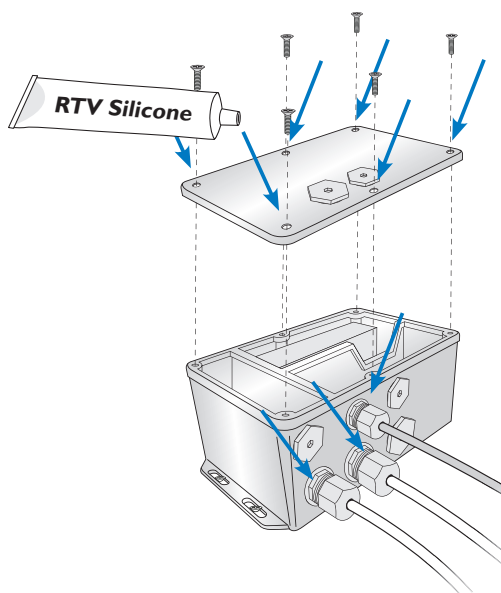

Replacing Fuses

Device	Replacement Fuse
PDS-60ca 7.5 V	(2) 5 A, 5 x 20 slow blow fuses
PDS-60ca 24 V	(2) 4 A, 5 x 20 slow blow fuses

PDS-60ca has a fuse for each of its ports, protecting each port from excessive current. Always replace blown fuses with the same rated fuse:

1. Make sure that the device's power is OFF.
2. Using a Phillips screwdriver, unscrew the six screws holding the cover in place.
3. Remove the blown fuse from its metal clips next to the fixture and data connection ports (see image on the right).
4. Replace the fuse with a new, identically-rated fuse.
5. Replace the cover, ensuring that the gasket is seated properly and that no wires are pinched.
6. Attach the cover with the six included screws. Tighten screws to 8 to 10 in-lbs (1 in-lb = 11.2985 N-cm). If you are installing in a wet or damp location, seal with RTV silicone.

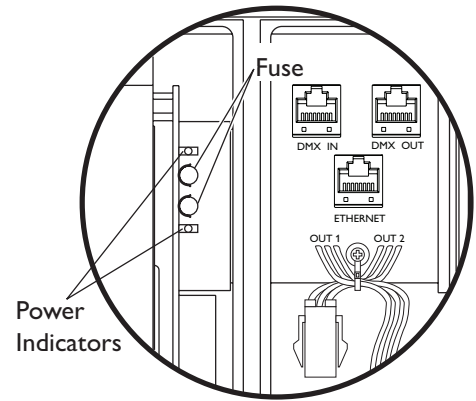

Philips Color Kinetics
3 Burlington Woods Drive
Burlington, Massachusetts 01803 USA
Tel 888.385.5742
Tel 617.423.9999
Fax 617.423.9998
www.philipscolorkinetics.com
@ColorKinetics

Copyright © 2011 - 2015 Philips Solid-State Lighting Solutions, Inc. All rights reserved. Chromacore, Chromasic, CK, the CK logo, Color Kinetics, the Color Kinetics logo, ColorBlast, ColorBlaze, ColorBurst, eW Fuse, ColorGraze, ColorPlay, ColorReach, iW Reach, eW Reach, DIMand, EssentialWhite, eW, iColor, iColor Cove, IntelliVWhite, iW, iPlayer, Optibin, and Powercore are either registered trademarks or trademarks of Philips Solid-State Lighting Solutions, Inc. in the United States and / or other countries. All other brand or product names are trademarks or registered trademarks of their respective owners. Due to continuous improvements and innovations, specifications may change without notice.

DAS-000060-00 R02 08-15