

StudioLive™
328i-W /
328i-B

 2,000 watt, 3-way, CoActual™
 Loudspeaker with TQ™ DSP
 and SL Room Control

- 2 x 8" 3-way, full-range, active loudspeaker
- 8" CoActual™ MF/LF speaker with integrated 1.75" compression driver
- Dual 8" ferrite LF transducers
- 133 dB maximum peak SPL
- 2,000 watts quad-amped Class D Pascal amplification
- Universal switch mode power supply with power-factor correction
- 24-bit floating point, 96 kHz DSP with asymmetric three-way crossover; Fulcrum Temporal Equalization™ for uncolored response and exceptionally crisp transient response, coaxial-speaker coherence alignment, and performance contouring; temperature and over-voltage protection; excursion limiting
- Wireless and wired control over output level, DSP presets, and much more with SL Room Control for iPad, Mac OS X, and Windows
- Three DSP contours
- 100 Hz highpass filter
- XMAX™ mic preamp with 15V phantom power
- Balanced, combo line input with attenuation
- Audio mix output
- Speaker attenuation control
- USB port for use with included USB Wi-Fi module and disaster recovery
- Ethercon connection for wired control
- Integrated grille cloth masks the drivers so they blend seamlessly
- 16 Integrated M10 fly points
- Available in white (328i-W) and black (328i-B)
- Optional Dante networking card



StudioLive™ AI-series 328i-W and 328i-B 3-way active loudspeakers combine high power and advanced coaxial configuration with the most powerful DSP engine ever built into a compact PA system. Through seamlessly integrated software, StudioLive AI speakers can be set up, adjusted and continuously monitored via wired or wireless remote control using Windows®, OS X® or iPad®. An optional card provides Dante networking.

Ideal for flown indoor installations.

Designed specifically for indoor flown installations, these models are available in white (328i-W) and black (328i-B) and have internal grille cloth that masks the drives so they blend seamlessly with their environment. Pole mounts and handles have been removed to facilitate flown installations. The front-panel blue power LED can be turned off in SL Room Control software.

Advanced 24-bit floating point digital signal processing.

StudioLive AI-Series loud-speakers were tuned by master speaker designer Dave Gunness using Fulcrum Acoustic's trade-marked Temporal Equalization™ algorithms. Previously possible only using powerful outboard rack processors, TQ™ is used to manage horn reflections, linear time and amplitude anomalies correction, performance contouring, and dynamic and excursion limiting.

The result is a coaxial speaker system with:

- Crisper stereo image
- Greater soundstage depth
- More separation between complex mix components
- Increased resistance to feedback
- More seamless transitions between distributed loudspeakers
- Less fatiguing listening experience at very high SPLs
- Exceptional clarity and coherence

Complete remote control.

The robust onboard CPU in all StudioLive AI speakers also makes possible an extensive set of control features for customizing and optimizing the system and for monitoring and fine-tuning performance in real time.

Since system EQ can be set up per speaker, independently of a mixer, mixer output EQs are freed up for other uses.

SL Room Control software for Mac OS X, Windows, and iPad provides each full-range speaker and groups of speakers with wired and wireless remote control of a variety of features.

Remote Control over:

- DSP contours
- 100 Hz highpass filter
- Front-panel blue power-status LED

Network setup wizard

- Network scanning automatically detects connected speakers
- Network browser

Performance monitoring over:

- Excursion limiting
- Real-time temperature
- ADC clip detection
- Power-amp soft limiting

Individual speaker DSP settings:

- 8-band parametric EQ
- 8 notch filters
- Speaker delay (up to 500 ms)
- Mute and solo
- Level

Group speaker management

- Group level control
- 31-band graphic EQ
- Store/load graphic EQ presets
- Speaker-group browser
- Store multiple speaker groups together
- Custom labels for each speaker and group

Settings are automatically stored in the User Layer onboard each loudspeaker for use away from SL Room Control.

Optional Dante networking.

The SL-Dante-SPK upgrade option card houses one Ethercon connection for Dante™ audio networking and remote control via SL Room Control. It offers two Dante Transmit and two Receive channels and operates at 48 kHz.

Dante-enabled StudioLive AI-series loudspeakers allow users to create a complete, networked audio system with any Dante-enabled mixer using a standard 1 GB Ethernet switch and Audinate's Dante digital-media networking technology, which offers self-configuring, true plug-and-play digital audio networking.

Users can also connect non-Dante mixers, such as a first-generation StudioLive, to the analog inputs of a Dante-equipped AI loudspeaker and then broadcast the signal over the Dante network using CAT5 cables. This makes Dante-enabled StudioLive AI loudspeakers an ideal solution for large front-of-house systems.



The CoActual approach to better speaker design.

The new CoActual driver uses a single magnet structure, shared by the midrange/woofer and compression driver. This results in a much more compact, lightweight assembly that keeps the compression-driver diaphragm located in close proximity to the larger cone voicecoil.

A purpose-built, high-frequency horn is used for high frequency pattern control and also to keep the HF energy off of the woofer cone. This allows StudioLive AI PA loudspeakers to remain sonically stable at high levels.

The crossover overlaps the HF horn and woofer, thereby allowing the compression driver to fill in the woofer frequency range that is shadowed by the horn. TQ™ processing allows the compression driver to work at lower frequencies without sonic artifacts.

The woofer's larger radiating surface works in conjunction with the HF horn to improve directional control at the bottom of the horn's operating range. This increases directional control beyond what can be accomplished by the horn alone.

At the low-frequency end of its range, a coaxial horn "leaks" sound back onto the woofer cone. This reflects forward, out of time, and produces tonal colorations that don't respond to conventional EQ. TQ™ eliminates these colorations, thereby removing one of the primary shortcomings of conventional coaxial designs. The result is extremely accurate transient reproduction, making the speaker less subject to intermodulation distortion.

STUDIOLIVE 328i TECHNICAL SPECIFICATIONS



Acoustic Performance

| | |
|-----------------------------|--|
| Configuration | 3-way, quad-amplified loudspeaker system |
| Frequency Response (-10 dB) | 54 Hz - 23 kHz |
| Frequency Response (-6 dB) | 59 Hz - 22 kHz |
| Nominal Coverage (-6 dB) | 90 x 60 |
| Maximum Peak SPL | 133 dB |
| Crossover Frequency | 1.7 kHz |
| Directivity Index (DI) | 10 dB, >460 Hz |
| Directivity Factor (Q) | 10.0, >460 Hz |

Transducer

| | |
|---------------|--------------------------|
| LF Transducer | 2 x 8" Ferrite |
| MF Transducer | 8" CoActual™ |
| HF Transducer | 1.75" compression driver |

Amplifier

| | |
|--------------------|--|
| Type | Class D |
| Total Power Output | 2,000W (total power without protection algorithms and limiter enabled) |
| LF Power | 2 x 500W |
| MF Power | 500W |
| HF Power | 500W |
| Rated THD | <0.05% (20 Hz - 20 kHz) |
| Dynamic Range | 119 dB (A-weighted) |
| Bandwidth | 20 Hz - 20 kHz |
| Cooling | Free air convection |

Connections and Controls

| | |
|-----------------------|--|
| Input Channels | 1 mic, 1 line |
| Input Connector Types | 1 XLR (F), 1 combo |
| Phantom Power | 15 VDC (CH1 only) |
| Mic Input Impedance | 1 kΩ |
| Line Input Impedance | 10 kΩ |
| Maximum Input | +22 dBu |
| Output Connector | 1 XLR (M) - Mix out |
| Controls | Mic Level (Variable: Off to +48 dB), Line Attenuation (Variable: -24 dB to 0 dB), Speaker Attenuation (Variable: -24 dB to 0 dB) |
| Indicators | DSP Preset, HPF On/Off, Network Connected, Network Activity, Wi-Fi Setup, Wi-Fi On, Signal, Limit, Clip, Thermal |

DSP

| | |
|-----------------|---|
| Contour Presets | Normal, LBR Source, Floor Monitor |
| HPF | 100 Hz, 4th-order Linkwitz-Riley |
| Bit Depth | 24-bit |
| Sample Rate | 96 kHz (48 kHz with Dante option installed) |

Enclosure

| | |
|------------------------|---|
| Material | Baltic birch |
| Finish | Chemline™ polyurethane |
| Grille | Powder-coated steel |
| Dimensions (H x D x W) | 30.1" x 15.7" x 13.3" (764.54 x 398.78 x 337.8mm) |
| Unit Weight | 51 lbs (23.13 kg) |
| Monitor Angle | 50° |

Safety

| | |
|------------------------|--|
| Amplifier Protection | Over-current, DC, over/under-voltage, over-temperature, high frequency |
| Transducer Protections | 4-ch. multi-threat limiter |

AC

| | |
|----------------------------------|---------------------|
| AC Power Input | 100-230V~, 50-60 Hz |
| AC Power Consumption (1/8 Power) | 250W |

Suspension/Mounting

| | |
|----------------|--------|
| Rigging Points | 16 M10 |
|----------------|--------|

Accessories/Replacement Parts

| | |
|-----------------------|---|
| USB Wireless | WF-150 |
| M10 Kit | M10AI-Kit |
| Protective Cover | SLS328AI-Cover |
| Dante Option Card | SL-Dante-SPK |
| Horizontal Yoke Mount | 328i-Yoke-H |
| Vertical Yoke Mount | 328i-Yoke-V |
| Replacement Parts | 355-NRG-COAX-8: 8" coaxial driver 355-NRG-LO-FREQ-8: 8" low-frequency driver |

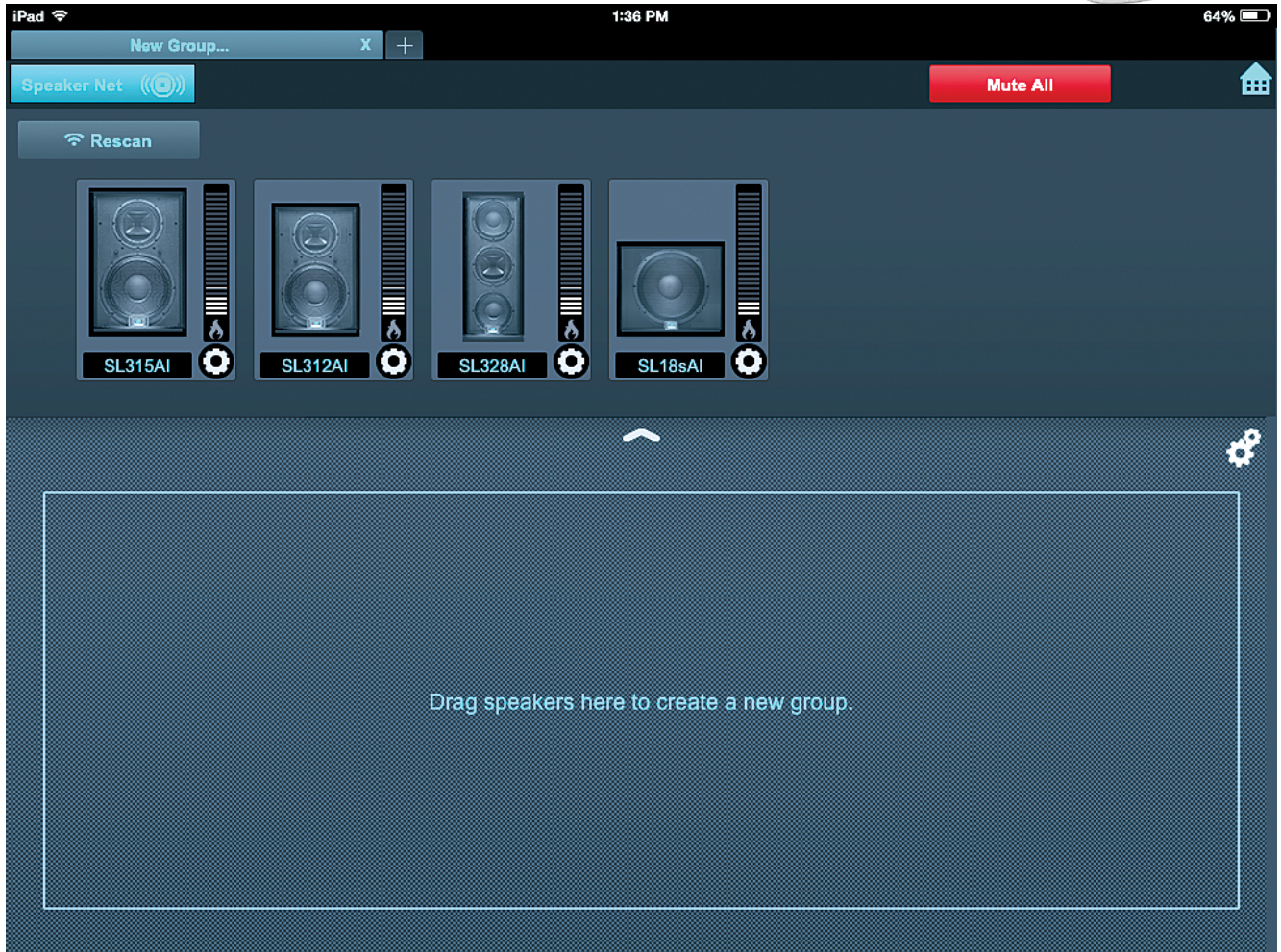

Drag-and-drop speakers from the network browser to create a new speaker group.



Wired and wireless integration with SL Room Control software.

The StudioLive 328i communicates with SL Room Control software over a wireless or wired LAN network and provides a wealth of system-control and performance-monitoring features.

SL Room Control is a speaker-management system and remote-control/monitoring software for StudioLive AI-series loudspeakers that runs under Windows, Mac OS X, and iOS for iPad.

Use the included USB Wi-Fi dongle to connect to an established wireless network or hardwire your

Speaker groups create a map of every speaker's settings and can be arranged to onscreen to reflect their position in the room.



The Speaker Edit page lets you set EQ and alignment delay, add notch filters, and remote-control onboard speaker settings.



The Group Edit page lets you set a graphic EQ for, and control the level of, the entire speaker group.

StudioLive loudspeaker to a wireless router using an Ethernet connection to provide more stable connectivity.

In addition to providing remote wireless control over all onboard features, SL Room Control includes speaker group management and individual speaker control including eight notch filters, eight-band parametric EQ, output delay, and performance monitoring. It also enables you to turn the front-panel blue power-status LED off. In short, this full-featured software opens up the power of the onboard DSP, providing optimization tools that were previously only available in standalone rack units.

SL ROOM CONTROL SOFTWARE

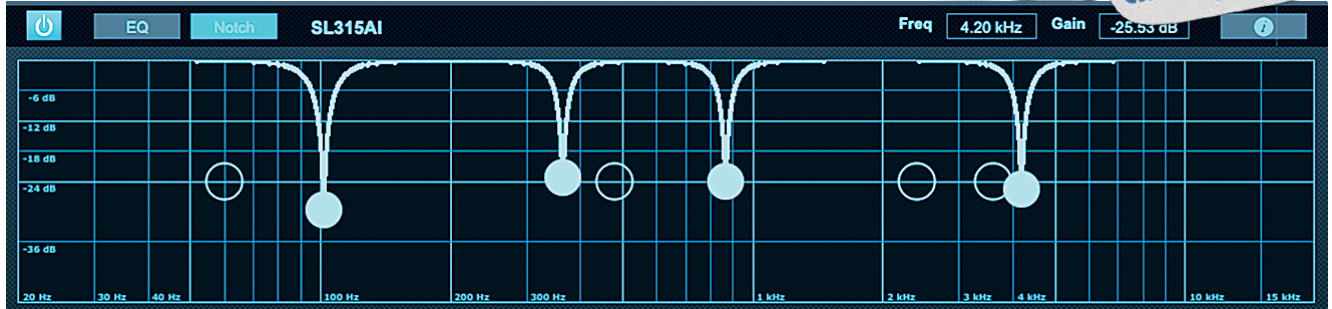

Onboard speaker delay.

Using multiple sets of speakers in a live performance can make a huge difference in the quality of the sound. Rather than relying on a pair of front-of-house speakers to fill the entire room, you can create listening zones throughout the room so that your front-of-house system only needs to be loud enough to cover the front of the room.

This allows you to lower the level, give the front-row listeners' ears a break, and get better fidelity from your speakers.

Delay systems allow you to provide the same listening experience throughout the entire venue by

extending the reach of the FOH system. The onboard DSP on the StudioLive AI-series loudspeakers allows you to achieve this experience without any additional equipment or wiring.

Onboard speaker grouping.

SL Room Control provides individual and grouped speaker management. Grouping speakers allows you to adjust the overall graphic EQ of your entire FOH or satellite system. In addition, you can mute or solo individual speakers in the system and quickly zoom in on different groups around the venue.



STUDIOLIVE 328i BACK PANEL

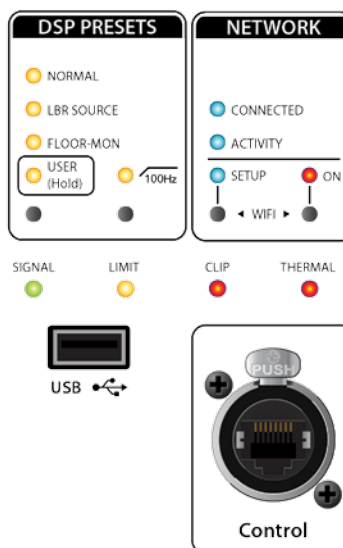
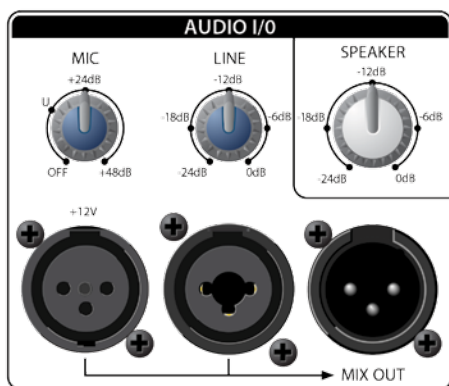

STUDIOLIVE 328i ARCHITECT AND ENGINEERING SPECIFICATIONS

General

The loudspeaker shall be self-powered and shall include two 8-inch LF cone transducers and one CoActual transducer with one 8-inch diameter, low-frequency/mid-frequency cone transducer and one integrated, horn-loaded 1.75-inch compression driver. Transducer protection shall consist of a 4-channel multi-threat limiter.

Internal Amplification

The loudspeaker shall incorporate four Class D power amplifiers, each with a burst capability of 500W total. Distortion (THD, IM, TIM) shall not exceed -0.05% (20 Hz - 20 kHz). Dynamic range shall be 119 dB (A-weighted). Bandwidth shall be 20 Hz - 20 kHz. Amplifier protection shall be overcurrent, DC, over/under voltage, overtemperature, and high frequency.

Performance Specifications

Performance for a typical production unit shall be as follows, measured at 1/3-octave resolution: operating frequency range 59 Hz to 22 kHz @ -6 dB; directivity index (DI) 10 dB, >460 Hz; directivity factor (Q) 10.0, >460 Hz; maximum peak SPL 133 dB. Horizontal and vertical coverage shall be 90 degrees by 60 degrees.

Rear Panel

Input connectors shall consist of one microphone (XLR F) with XMAX™ microphone preamplifier and one line (combo) input. 15 VDC phantom power shall be provided to CH1 mic preamp. Mic input impedance shall be 1 k Ω ; line input impedance shall be 10 k Ω . Maximum input shall be $+22$ dBu. An output connector (XLR M) shall be provided for Mix output. Controls shall consist of Mic Level (Variable: Off to $+48$ dB), Line Attenuation (Variable: -24 dB to 0 dB), Speaker Attenuation (Variable: -24 dB to 0 dB). Indicators shall consist of DSP Preset, HPF On/Off, Network Connected, Network Activity, Wi-Fi Setup, Wi-Fi On, Signal, Limit, Clip, and Thermal. A USB socket shall be provided for Wi-Fi communication and internal software recovery. A CAT 5 Ethercon connection shall also be provided.

Digital Signal Processing

The speaker processing shall have 24-bit depth and 96 kHz sample rate. The speaker shall have Normal, LBR Source, and Floor Monitor Control presets and a 100 Hz 4th-order Linkwitz-Riley highpass filter.

Software

The speaker shall have the option to be controlled by SL Room Control for Windows 7 and 8 (32- and 64-bit support), Mac OS X 10.7 Lion and 10.8 Mountain Lion, and iPad iOS 7 or later. SL Room Control shall provide remote control over onboard DSP contours and highpass filter; network scanning to detect all speakers;

network browser; performance monitoring of excursion limiting, real-time temperature, ADC clip detection, and soft limiting; multiple speaker group management with relative level control, 31-band graphic EQ with preset browser, and speaker mapping; 8-band parametric EQ, 8 notch filters (Q:24), alignment delay (up to 500 ms), limiter with variable threshold, DSP input level, solo, mute, custom labels, and preset browser for each speaker; and onboard User layer to store speaker settings, with or without SL Room Control connected.

Dante Networking Option

An optional card shall be available that houses one Ethercon connection for Dante™ audio networking and remote control via SL Room Control software. The option card shall provide two Dante transmitting and two receiving channels and shall operate at 48 kHz.

Power Requirements

The power requirements for the loudspeaker shall 100 to 230V~ 50-60 Hz. Current draw for the loudspeaker at 1/8 power shall be 250W.



StudioLive 328i
3-way PA
Loudspeaker

PreSonus
CONTRACTOR

Physical

Loudspeaker components shall be housed in an enclosure composed of 15 mm birch with a white (328i-W) or black (328i-B) Chemline™ coating. Internal grille cloth shall be designed to mask the drivers so that they blend into their environment.

Dimensions shall be 15.11" (384 mm) wide by 29.13" (741.5 mm) high by 15.7" (398 mm) deep, including the grille. Weight shall be 51 lbs (23.13 kg). Sixteen M-10 inserts on the enclosure shall accommodate rigging hardware.

The loudspeaker shall be the PreSonus StudioLive 328i-W or StudioLive 328i-B.

SL 328i FLY POINTS • See Rigging Guide before attempting to fly the speakers.

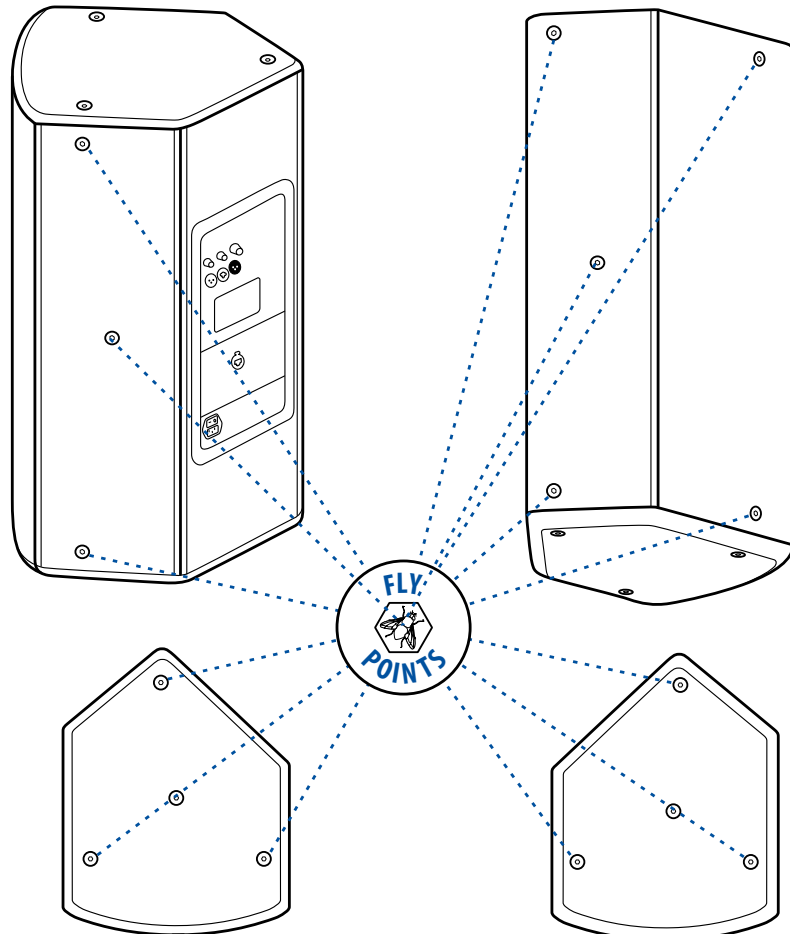

STUDIOLIVE 328i BLOCK DIAGRAM

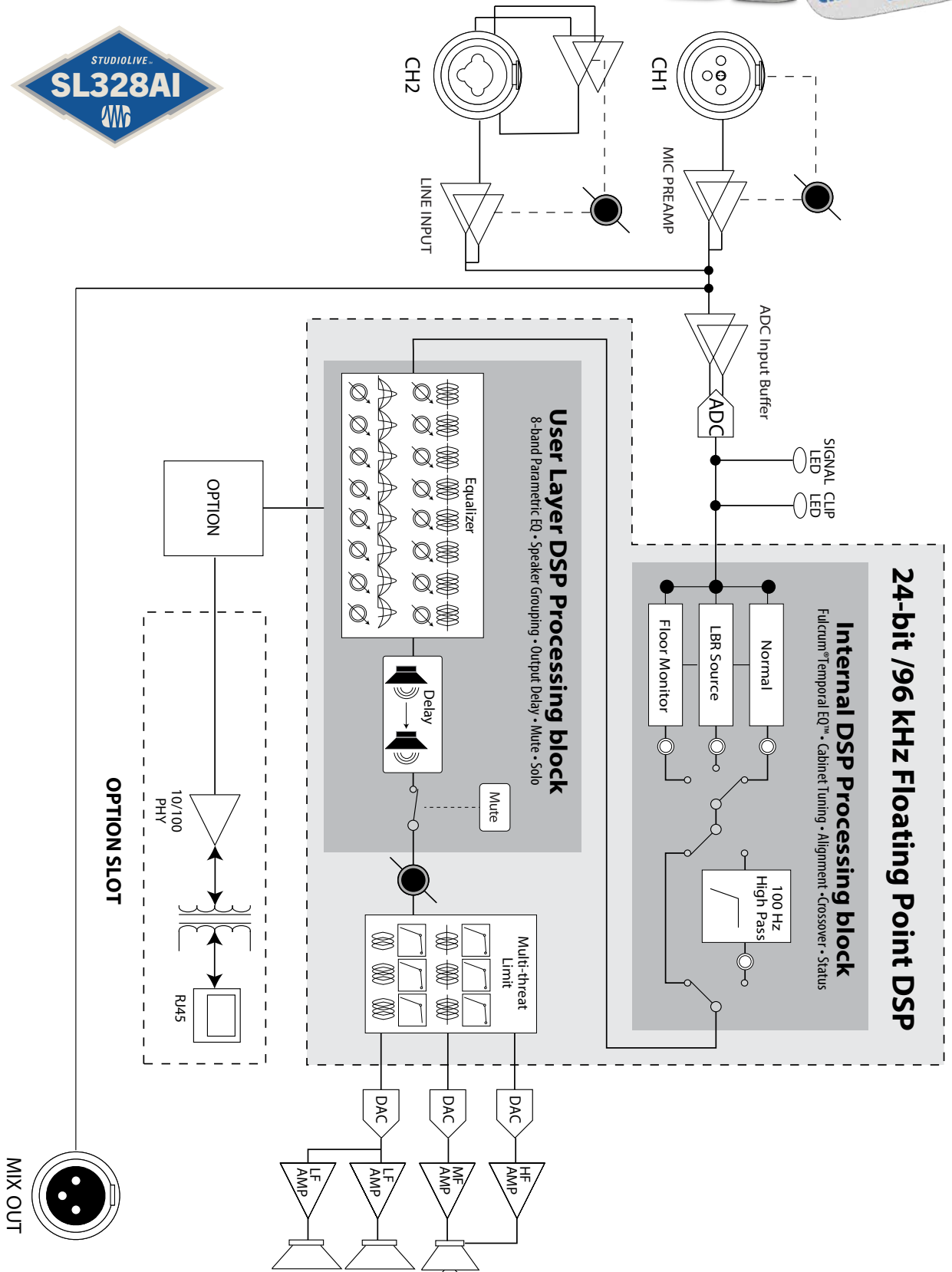

DANTE CARD INSTALLATION

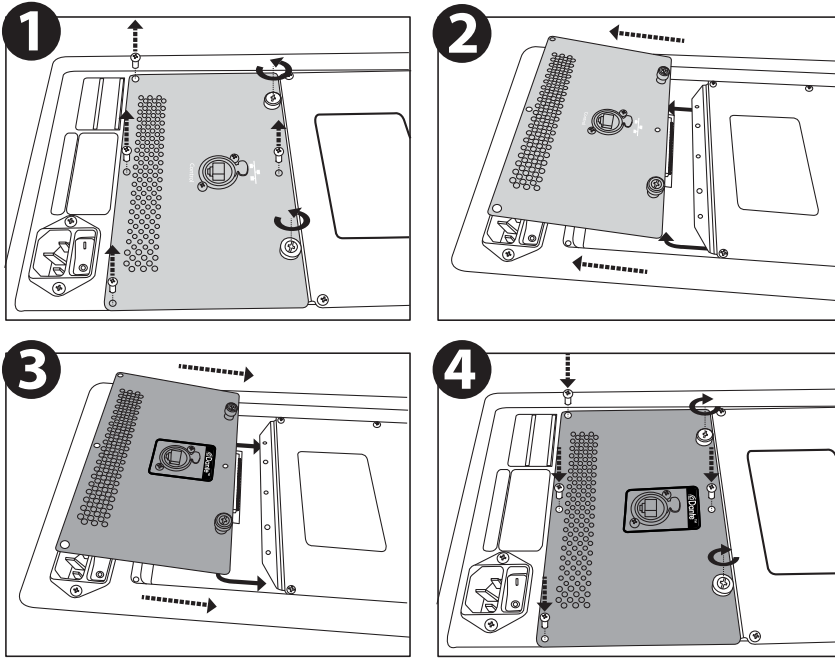

The SL-Dante-SPK upgrade option card houses one Ethercon connection for Dante™ audio networking and remote control via SL Room Control. It offers two Dante Transmit and two Receive channels and operates at 48 kHz.

Dante-enabled StudioLive AI-series loudspeakers allow users to create a complete, networked audio system with any Dante-enabled mixer using a standard 1 GB Ethernet switch and Audinate's Dante digital-media networking technology, which offers self-configuring, true plug-and-play digital audio networking.

Users can also connect non-Dante mixers, such as a first-generation StudioLive, to the analog inputs of a Dante-equipped AI loudspeaker and then broadcast the signal over the Dante network using CAT5 cables. This makes Dante-enabled StudioLive AI an ideal solution for large front-of-house systems.

STUDIOLIVE 328i DIMENSIONS

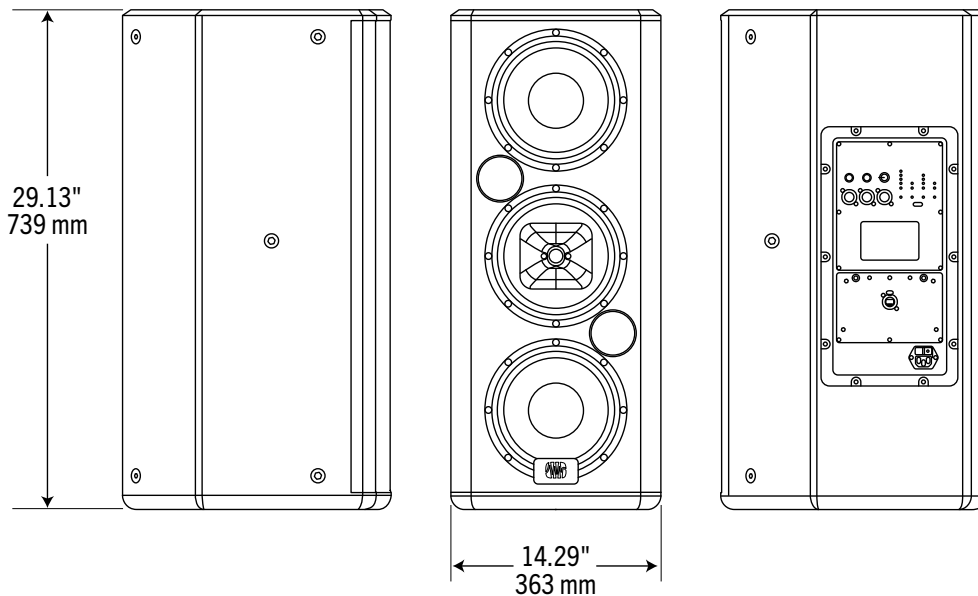
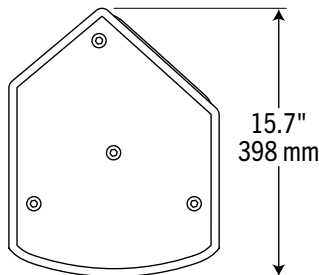

ANALOG CONSOLE DIAGRAM

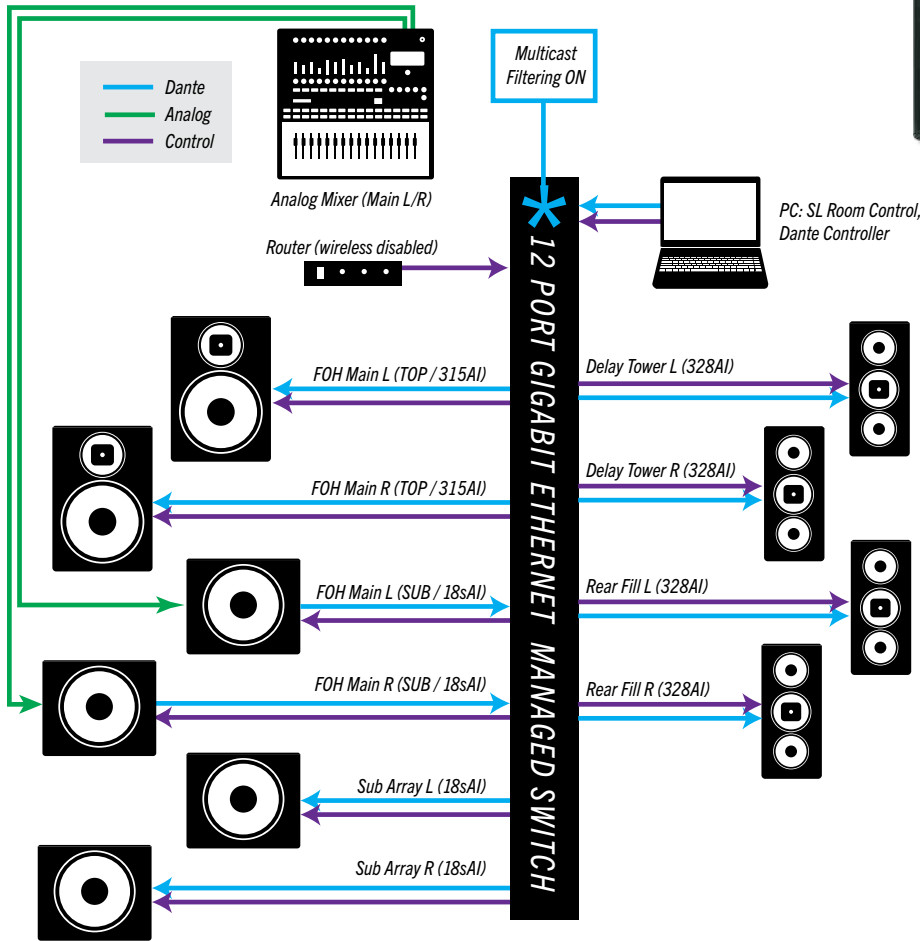

ANALOG FAIL-OVER

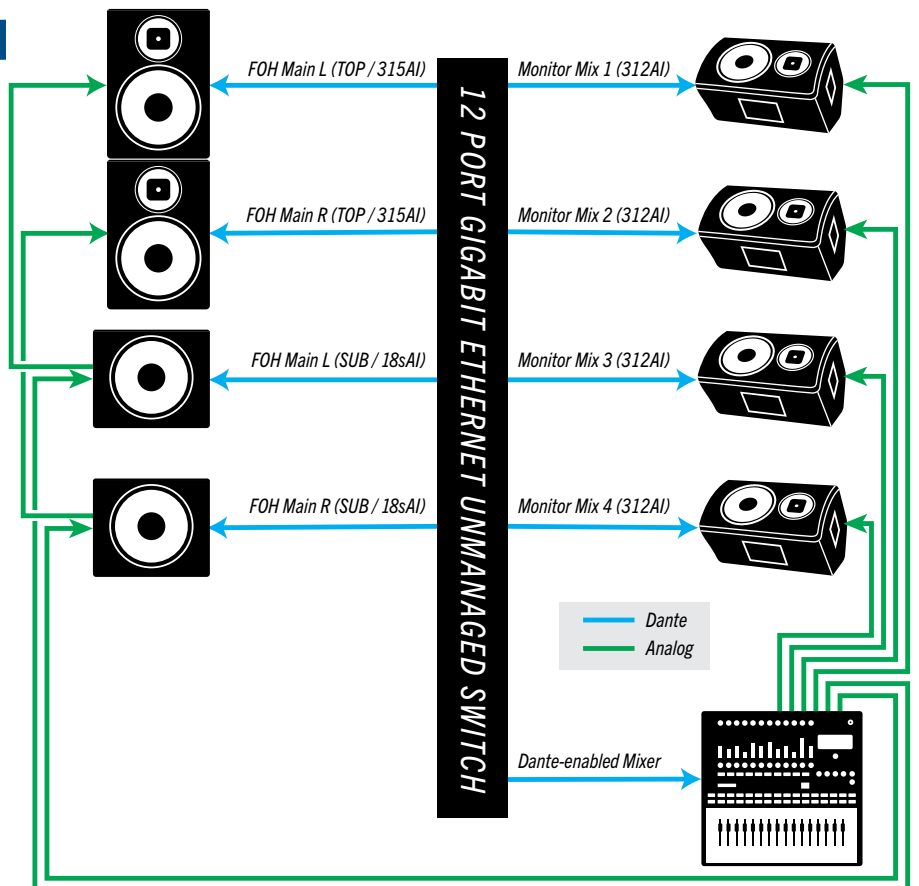

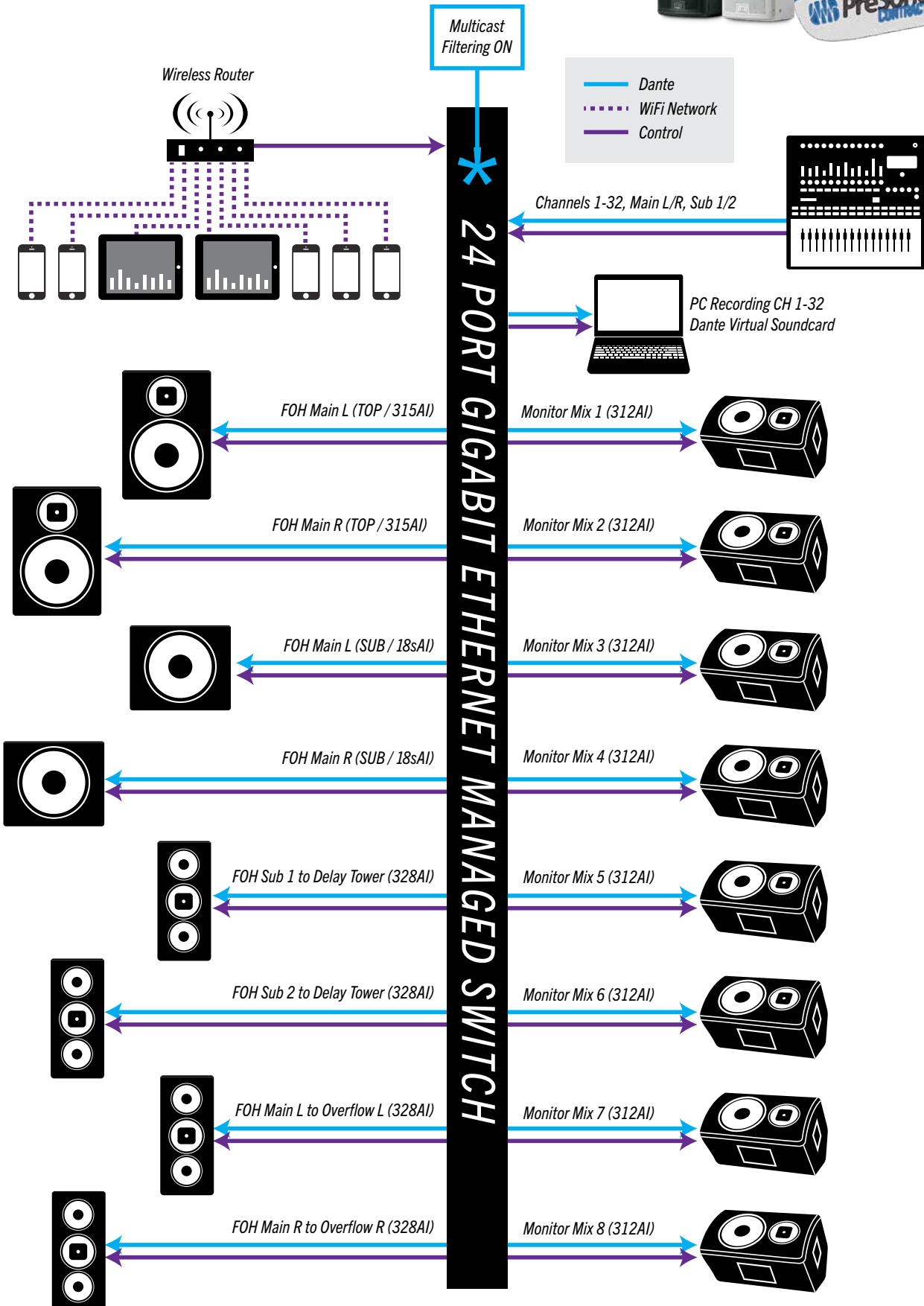



StudioLive™ 328i-W / 328i-B

2,000 watt, 3-way, CoActual™
Loudspeaker with TQ™ DSP
and SL Room Control

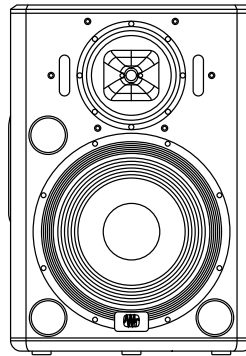
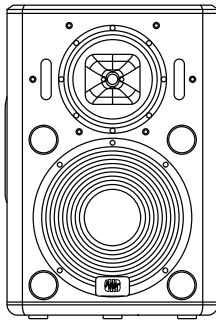
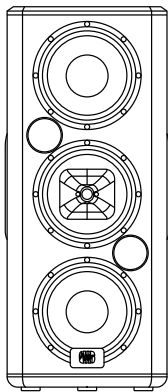
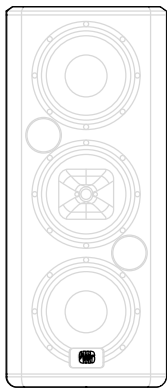
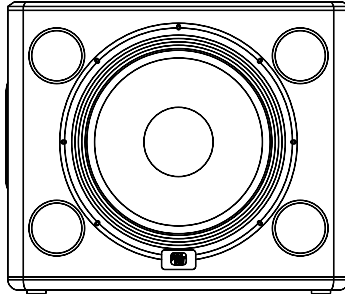

STUDIOLIVE 328i BEAM WIDTH AND RESPONSE GRAPHS

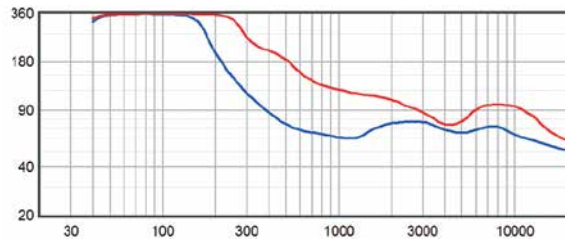

Beam Width

Vertical

Horizontal

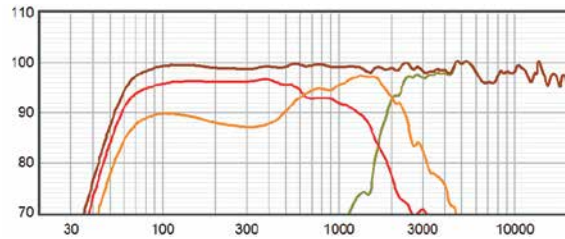

Individual Response

LF Transducer

Midrange

HF Transducer

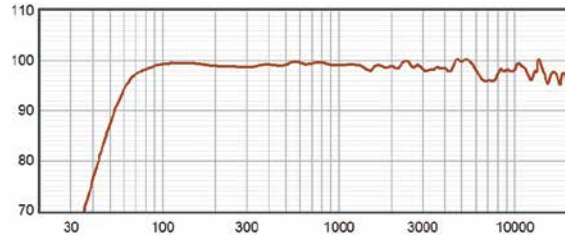

Summed Response

File Resources

To obtain these documents, please go to the following Web page and click on the Downloads tab:

www.presonus.com/products/StudioLive-AI-PA-Series

This data sheet:

PreSonus_StudioLive_328i.pdf

2D CAD drawing:

PreSonus_StudioLive_AI-Series_PA.dxf

A&E Specs:

PreSonus_StudioLive_328i_AE.doc

Applications brochure:

PreSonus_StudioLive_AI-Series_Applications.pdf

Compliance statement:

PreSonus_StudioLive_328i_Compliance.pdf

EASE GLL:

PreSonus_StudioLive_AI-Series_EASE_GLL_RevA.zip

Related PreSonus Products

- StudioLive 18sAI Subwoofer
- StudioLive 312AI Loudspeaker
- StudioLive 315AI Loudspeaker
- StudioLive 328AI Loudspeaker
- WF-150 Wi-Fi dongle
- M10AI-Kit M-10 mounting kit
- SLS328AI-Cover dustcover
- SL-Dante-SPK Dante option card
- 355-NRG-COAX-8 8" coaxial driver
- 355-NRG-LO-FREQ-8 8" low-frequency driver
- 328i-Yoke-H Horizontal Yoke Mount
- 328i-Yoke-V Vertical Yoke Mount

©2014 PreSonus Audio Electronics, Inc. All Rights Reserved. StudioLive, CoActual, and XMAX are trademarks of PreSonus Audio Electronics, Inc. Temporal Equalization is a trademark of Fulcrum Acoustic. Dante is a trademark of Audinate. Windows is a registered trademark of Microsoft. iPad is a registered trademark of Apple, Inc. All specifications are subject to change.

