



RDL® Radio Design Labs®

SPECIALISTS IN PRACTICAL PRECISION ENGINEERING™



RACK-UP® SERIES

Model RU-PA518

Audio Power Amplifier

ANYWHERE YOU NEED...

- Compact, 1/3-Rack width Amplifier
- Selectable Stereo or Bridged Mono
- 9 W RMS Stereo, 18 W RMS Mono
- Front Panel Control for 2 Inputs
- Selectable Built-In Peak Limiter
- Clean, Transparent Audio Quality

You Need The RU-PA518!



The RU-PA518 is part of the group of versatile RACK-UP products, featuring the advanced circuitry for which RDL products are known, combined with accessible, user-friendly controls and displays. The ultra-compact design permits high-density installations, with *three* products mounted in a single rack unit! The RU-PA518 may be placed on a shelf or mounted below a shelf using optional mounting brackets. Optional rack-mount adapters (RU-RA3) are available for conventional RACK-UP series installation.

APPLICATION: The RU-PA518 is a very versatile audio amplifier ideally suited to a wide variety of installations. This amplifier features two modes of operation: stereo and bridged mono. Each mode is switch selectable on the rear panel.

In stereo mode, each of the two inputs feed its respective left or right output. Front-panel level controls set the gain for left (channel A) and right (channel B). When the rear-panel switch is set to the bridge mode, the two inputs (A and B) are mixed together and fed to the output.

In either the stereo or mono modes, an internal audio peak limiter may be turned on using a rear-panel switch. The limiter protects the speakers from high transient audio peaks which permits more of the amplifier's power to be delivered to the speakers without clipping. This allows the RU-PA518 to deliver more unclipped power than is possible in a typical power amplifier of similar power rating. A front-panel LED flashes when the peak limiter operates, permitting accurate audio gain setting when operating at high levels.

In stereo mode, the RU-PA518 can be connected to either an 8 Ω or 4 Ω load, delivering more than 5 W RMS at 8 Ω or more than 9 W RMS into 4 Ω . In the bridge mono mode, the amplifier can deliver more than 18 W RMS into 8 Ω .

Each of the audio inputs is provided with both balanced and unbalanced connections. Balanced audio is connected through a rear-panel full-size barrier block. Unbalanced audio is connected through a standard phono input jack. Outputs are available on a barrier block. 24 Vdc power is connected through either barrier block terminals or through a dc power jack mounted on the rear panel. Front-panel controls include two audio level knobs and a power switch with an LED indicator.

With its high performance, small size and professional appearance, the RU-PA518 is the ideal power amplifier in its power range. Use the RU-PA518 individually, or combine it with other RDL RACK-UP or STICK-ON® products as part of a complete audio/video system.



RACK-UP® SERIES

Model RU-PA518

Audio Power Amplifier

Installation/Operation



EN55103-1 E1-E5; EN55103-2 E1-E4
 Typical Performance reflects product at publication time
 exclusive of EMC data, if any, supplied with product.
 Specifications are subject to change without notice.

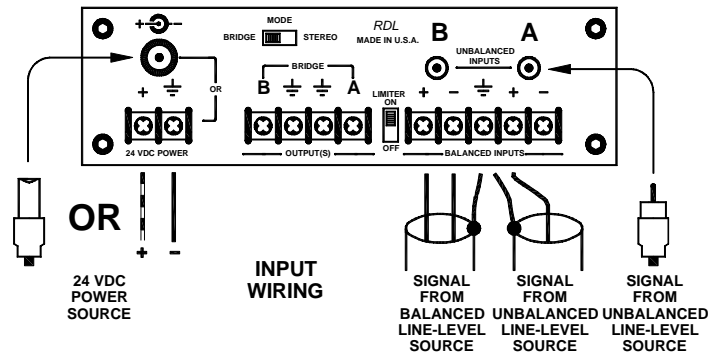

EACH INPUT MAY BE WIRED BALANCED OR UNBALANCED

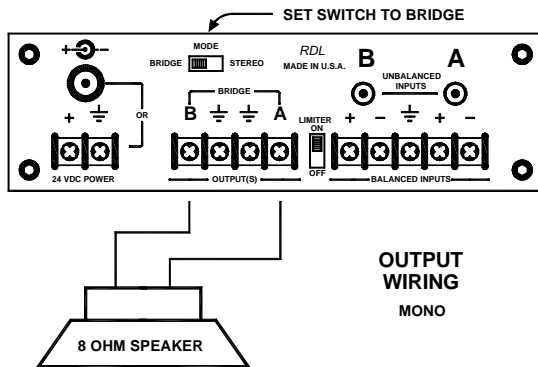

OUTPUT WIRING
MONO

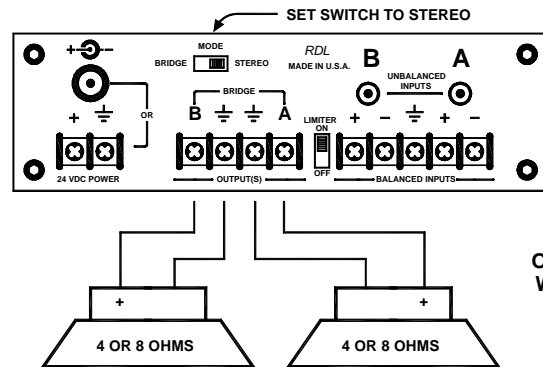

OUTPUT WIRING
STEREO

TYPICAL PERFORMANCE

Inputs(2):	Line level (+4 dBu nominal balanced) (-10 dBV nominal unbalanced)
Input Impedance:	20 kΩ balanced bridging 10 kΩ unbalanced
Input Connectors:	Balanced on terminal block; Unbalanced on phono jack
Minimum Input Levels:	
Balanced:	-6 dBu for rated power output
Unbalanced:	-20 dBV for rated power output
Maximum Input Levels:	
Balanced:	+20 dBu
Unbalanced:	+6 dBV
Frequency Response:	
Stereo (5W RMS, 8Ω):	20 Hz to 40 kHz (+/- 1 dB)
Stereo (9W RMS, 4Ω):	25 Hz to 40 kHz (+/- 1 dB)
Mono (18W RMS, 8Ω):	25 Hz to 30 kHz (+/- 1 dB)

THD+N:	< 0.05% below rated power (@ 1 kHz) < 0.1% below 18 W RMS (50 Hz to 20 kHz)
CMRR:	> 55 dB (50 Hz to 120 Hz)
Output Power:	
Stereo Mode:	> 5 W RMS per channel into 8 Ω > 9 W RMS per channel into 4 Ω
Mono Mode:	> 18 W RMS into 8 Ω
Crosstalk:	< -60 dB (stereo mode, 1 kHz)
Power Requirement:	24 to 33 Vdc @ 1500 mA (for continuous RMS power output, Ground referenced) 24 to 33 Vdc @ 1000 mA (for continuous music or voice output, Ground referenced)