



**RDL**® Radio Design Labs®

SPECIALISTS IN PRACTICAL PRECISION ENGINEERING™

## FLAT-PAK™ SERIES

### Model FP-ALC2

### Automatic Level Control

#### ANYWHERE YOU NEED...

- Consistent Levels from Variable Sources
- Split-Band AGC for Audio Transparency
- Self-Adjusting Attack and Release Times
- AGC with Simple Single Control Setup
- Level Control Range >20 dB
- Gated Control to Avoid Level "Seeking"
- Convenience of RDL FLAT-PAKs

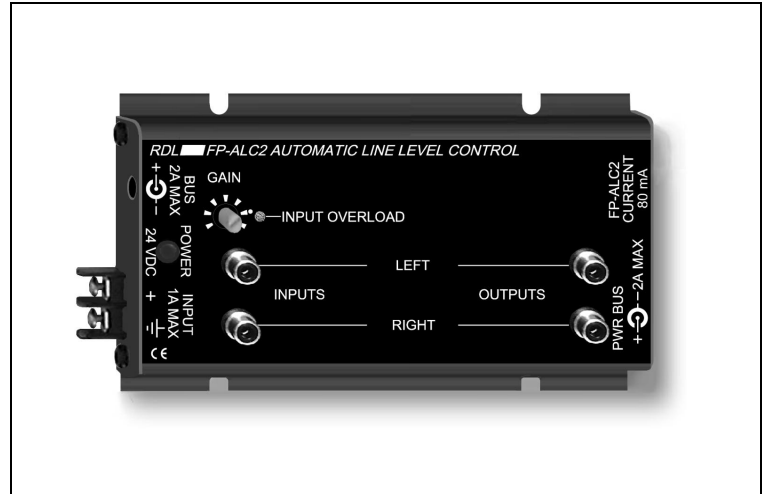

#### *You Need The FP-ALC2!*

The FP-ALC2 is part of the group of versatile FLAT-PAK products from Radio Design Labs. The unique FLAT-PAK case can be directly screwed or bolted to cabinets or shelves. Optionally available rack-mounting accessories permit single or multiple FLAT-PAK module mounting. All FLAT-PAK modules are supplied with a power interconnect cable for daisy-chaining multiple modules from a single power supply.

**APPLICATION:** The FP-ALC2 is the ideal choice in many applications where consistent stereo audio levels are needed from consumer sources with varying audio output levels. Power connections are made using either the full-size barrier block terminals or a dc power jack located in one end panel. A second dc power jack is provided on the other end panel for connecting additional FLAT-PAK modules.

The FP-ALC2 is a two channel (stereo) module featuring phono jack **INPUTS** and **OUTPUTS**. A single user adjustment makes installation simple and efficient. The gain adjustment is set as high as possible with the loudest source without the **INPUT OVERLOAD** indicator flashing. No further adjustments are needed. Foreground as well as background sound systems fed from variable audio source levels, such as multiple CD changers or satellite receivers, benefit from consistent levels.

The automatic level control circuitry in the FP-ALC2 maintains a consistent  $-10$  dBV output for input signal variations as great as 25 dB. Yet the operation of the module is nearly transparent to the listener for a wide variety of source material from rock to classical. The level pumping effect frequently associated with automatic gain and compression devices is minimized in the FP-ALC2 by controlling mid and high band audio separately from the bass frequencies. The automatic gain circuitry and compression attack release times adjust according to the program material to further reduce any audible effects of the module. The level seeking effect also associated with various automatic level products is avoided in the FP-ALC2. When audio levels fall and remain below a level appropriate to that source, the module stops increasing the gain. As audio levels fade out, the module tracks the level for a natural sound. These features combine to produce nearly inaudible adjustment yet consistent levels without the listener fatigue associated heavily compressed music dynamics.

The FP-ALC2's low profile and compact size permit mounting in confined spaces and in various locations in equipment racks. The location of the input/output jacks permits high density mounting against flat surfaces while maintaining accessibility to the connectors. The economical cost can provide assurance of correct signal levels in nearly any stereo audio system. The FP-ALC2 may be mounted where needed, to rack sides or in an equipment rack (either the front or rear rack rails) using the RDL FP-RRA. Use the FP-ALC2 individually, or combine it with other RDL products as part of a complete audio/video system.



# FLAT-PAK™ SERIES

## Model FP-ALC2

### Automatic Level Control

## Installation/Operation



EN55103-1 E1-E5; EN55103-2 E1-E4  
 Typical Performance reflects product at publication time exclusive of EMC data, if any, supplied with product. Specifications are subject to change without notice.

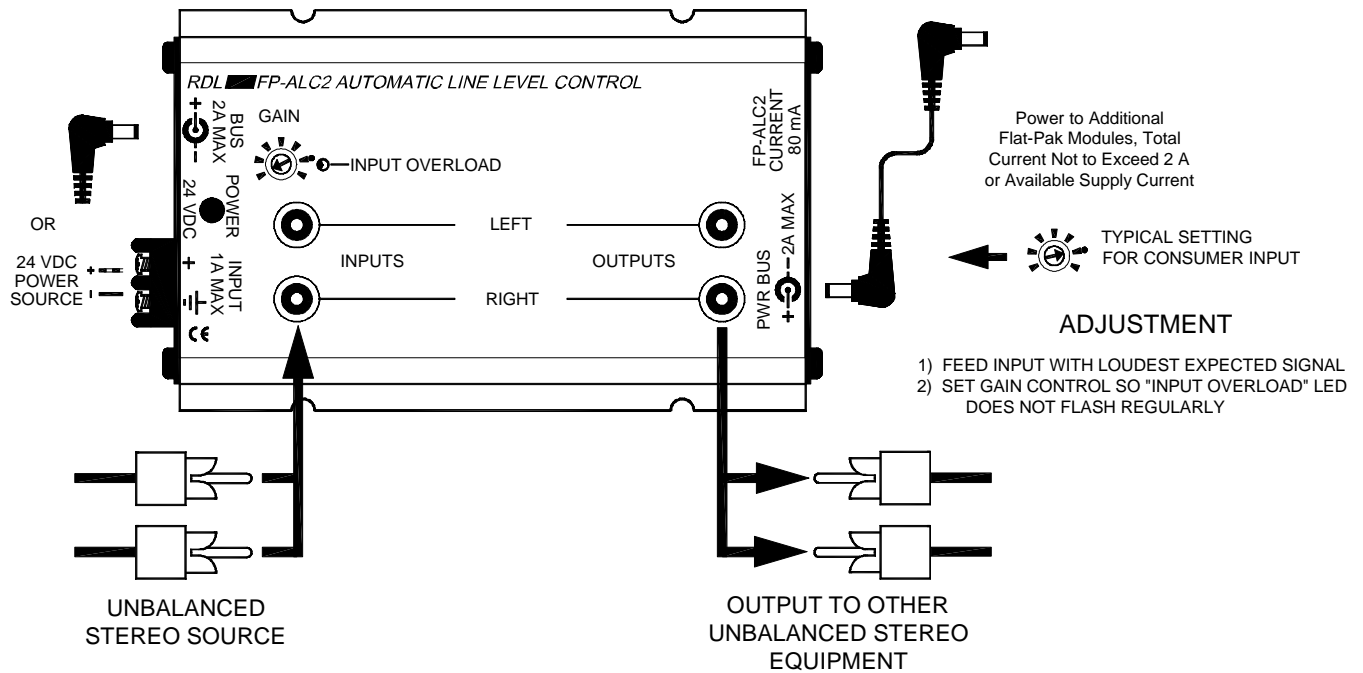

### TYPICAL PERFORMANCE

Inputs (2):	10 kΩ unbalanced phono jack
Input Level:	-10 dBV (nominal)
Output:	200 Ω unbalanced phono jack
Output Level:	-10 dBV
Automatic Level Range:	-30 to 0 dBV
Gate Threshold:	-40 dBV (20 Hz to 3 kHz)
Frequency Response (excluding AGC):	20 Hz to 20 kHz (+/- 0.5 dB)
THD+N (excluding AGC):	< 0.15% (20 Hz to 20 kHz)
Noise:	< -90 dB (below -10 dBV)
Crosstalk:	-75 dB (typical, 1 kHz)
Headroom:	> 18 dB
Indicator (1):	<b>INPUT OVERLOAD</b>
Power Requirement:	24 Vdc @ 80 mA, Ground-referenced
Overall Dimensions:	Height: 1.20 in. 3.05 cm
	Width: 3.25 in. 8.26 cm
	Length: 5.75 in. 14.61 cm