



**RDL**® Radio Design Labs®

SPECIALISTS IN PRACTICAL PRECISION ENGINEERING™

## FLAT-PAK™ SERIES

### Model FP-MX4 Mic / Line Mixer

#### ANYWHERE YOU NEED...

- Four Channel Audio Mixer
- Balanced Microphone and Line Inputs
- Balanced Microphone and Line Outputs
- Switch Selectable 24 V Mic Phantom
- Three Switch Selectable Mic Gain Ranges
- Studio Quality, Low Noise Performance
- Convenience of RDL FLAT-PAKs

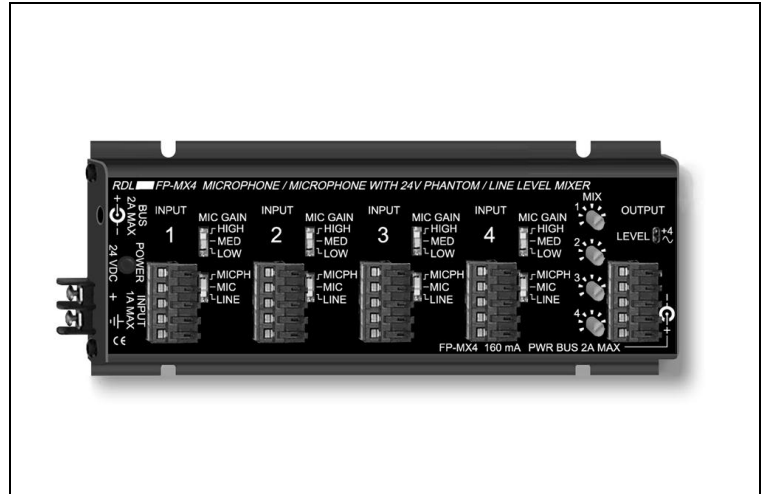

#### *You Need The FP-MX4!*

The FP-MX4 is part of the group of versatile FLAT-PAK products from Radio Design Labs. The unique FLAT-PAK case can be directly screwed or bolted to cabinets or shelves. Optionally available rack-mounting accessories permit single or multiple FLAT-PAK module mounting. All FLAT-PAK modules are supplied with a power interconnect cable for daisy-chaining multiple modules from a single power supply.

**APPLICATION:** The FP-MX4 is the ideal choice in many applications requiring mixing of microphone and line level sources at preset levels. Power connections are made using either the full-size barrier block terminals or a dc power jack located in one end panel. A second dc power jack is provided on the other end panel for connecting additional FLAT-PAK modules.

The FP-MX4 is a single channel audio mixing module featuring four identical inputs. Each input section has a detachable terminal block, a source selection switch and a microphone gain switch. The output section provides four mixing potentiometers corresponding to the four inputs, a detachable terminal block for the audio outputs and a level indicator.

Either microphone or line level audio is connected to each input terminal block. Each input may be wired balanced or unbalanced. The source switch selects from three inputs types: **LINE** (line level at +4 dBu), **MIC** (microphone level without phantom), **MICPH** (microphone level with 24 V phantom). For either microphone input setting, a separate **MIC GAIN** switch selects: **LOW** (35 dB – 45 dB), **MED** (45 dB – 55 dB), **HIGH** (55 dB – 65 dB). Separate source and gain switches are provided for each input channel, allowing any combination of 4 sources to be used simultaneously. The microphone inputs feature RDL's exclusive low noise discrete preamplifier stage providing performance usually reserved for studio equipment.

The four mixing potentiometers are intended to be set at installation or to be adjusted occasionally. The shafts may be adjusted either using a small screwdriver or manually without any tools. Any unused channel may be turned completely off. The output section provides both a balanced line (+4 dBu) and balanced microphone level (-45 dBu) output. Both outputs may be used at the same time.

Output level adjustment is simplified by the dual LED output meter which follows standard VU ballistics. A green LED illuminates at 15 dB below +4 dBu. The intensity of the green LED progresses from minimum at -11 dBu to full intensity at +4 dBu. The adjacent red LED illuminates at +4 dBu. The audio may be adjusted for maximum intensity of the green LED. Flashing of the red LED is equivalent to a VU meter needle swinging above the 0 level.

The FP-MX4's low profile and compact size permit mounting in confined spaces and in various locations in equipment racks. The location of the input/output jacks permits high-density mounting against flat surfaces while maintaining accessibility to the connectors. The wide variety of input signal levels and internal selectable phantom powering make the FP-MX4 ideal in diverse installations. The FP-MX4 may be mounted where needed, to rack sides or in an equipment rack (either the front or rear rack rails) using the RDL FP-RRA. Use the FP-MX4 individually, or combine it with other RDL products as part of a complete audio/video system.



## FLAT-PAK™ SERIES

### Model FP-MX4 Mic / Line Mixer

## Installation/Operation



EN55103-1 E1-E5; EN55103-2 E1-E4  
Typical Performance reflects product at publication time exclusive of EMC data, if any, supplied with product. Specifications are subject to change without notice.

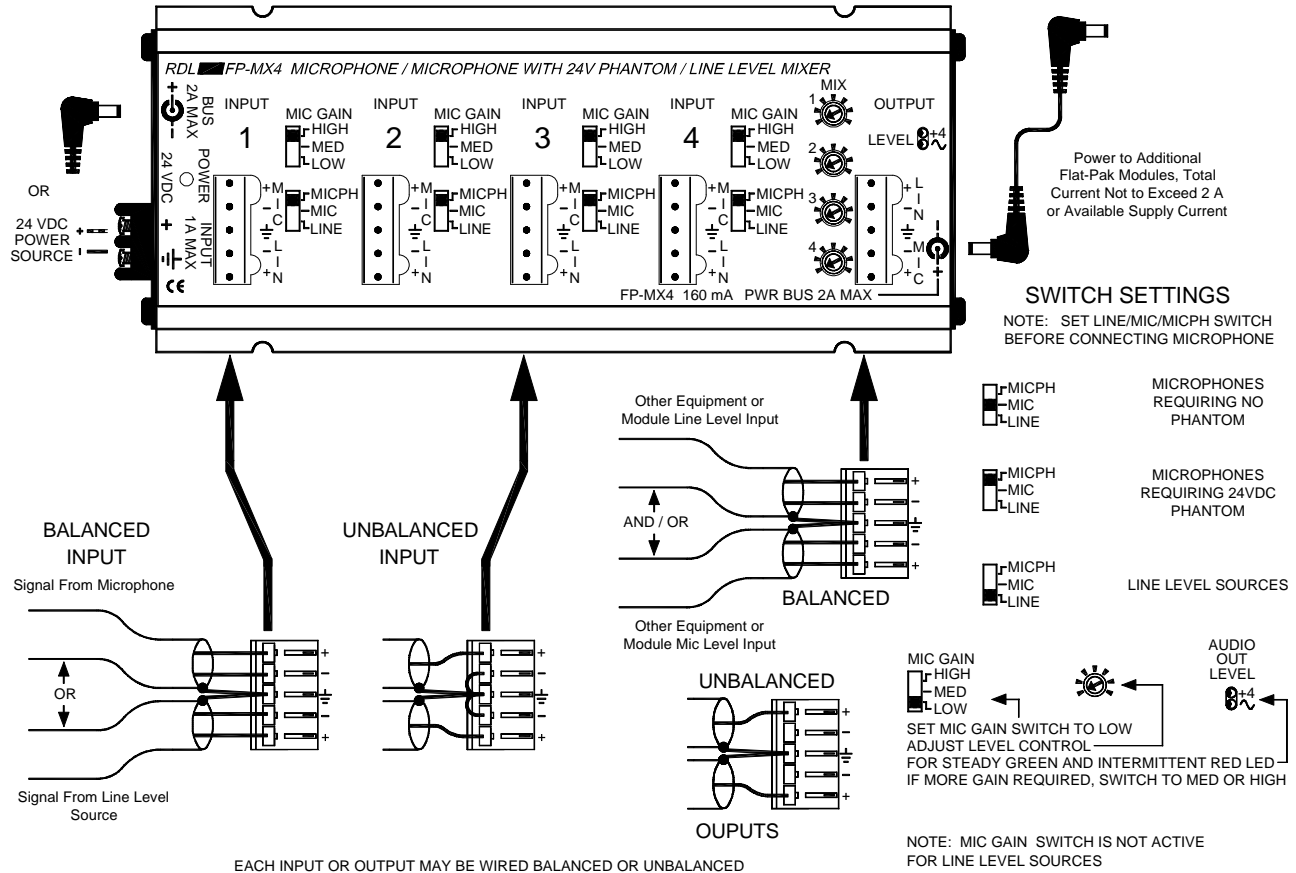

### TYPICAL PERFORMANCE

Microphone Inputs(4):	2 kΩ balanced, switchable 24 V phantom (IEC 1938: 1996-12)
Microphone Input Level:	Switch selectable ranges: -30 to -40 dBu, -40 to -50 dBu, < -50 dBu
Line Inputs (4):	10 kΩ balanced (may be wired unbalanced)
Line Input Level:	+4 dBu
Gain Adjustments (4):	Mic: Off to 65 dB gain (max. gain range); line: Off to 6 dB gain
Frequency Response:	
Mic:	10 Hz to 30 kHz (+/- 0.25 dB)
Line:	10 Hz to 45 kHz (+/- 0.25 dB)
THD+N:	
Mic:	< 0.012%
Line:	< 0.004%
Residual Noise (below +4dBu output):	4 line level sources (unity gain): < -84 dB (wideband)
40dB Gain:	Mic: -90 dB; all 4 mic level sources: < -82 dB (wideband); < -84 dB ("A" weighted)
50dB Gain:	Mic: -86 dB; all 4 mic level sources: < -72 dB (wideband); < -76 dB ("A" weighted)
60dB Gain:	Mic: -80 dB; all 4 mic level sources: < -65 dB (wideband); < -67 dB ("A" weighted)
Outputs (2):	Line: +4 dBu 150 Ω balanced; mic: -45 dBu 150 Ω balanced
Indicators (2)	Audio level meter
Power Requirement:	24 Vdc @ 160 mA, Ground-referenced
Overall Dimensions:	Height: 1.42 in. 3.61 cm
	Width: 3.25 in. 8.26 cm
	Length: 8.14 in. 20.68 cm

### Radio Design Labs Technical Support Centers

U.S.A. (800) 933-1780, (928) 778-3554; Fax: (928) 778-3506  
 Europe [NH Amsterdam] (+31) 20-6238 983; Fax: (+31) 20-6225-287