

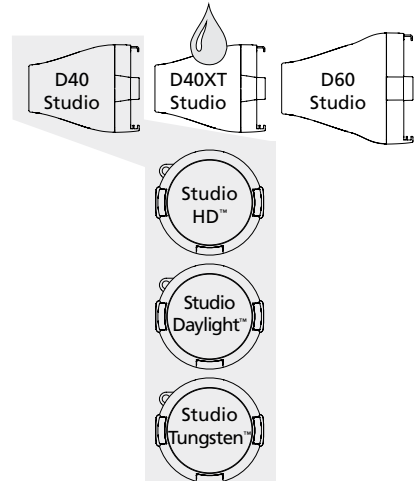

100V 115/120V 230/240V



This datasheet covers D40 Studio fixtures as shown. See other datasheets for other versions.

GENERAL INFORMATION

ETC's Selador® Desire D40 Studio lighting fixtures use the newest technology in high-output white-light LEDs to create an ideal luminaire for video, film and other 'white light only' applications. Three different LED options give the user a choice for just the right white-light output for the job. The D40 Studio offers a rugged die-cast enclosure, noiseless fan-free operation, multiple lens options and an advanced user interface. The user interface enables easy configuration and specific features for video and film applications. The fixture can be configured to operate under console control for studio systems or in stand-alone 'no console required' mode for location lighting.

D40 STUDIO LED ARRAY OPTIONS

D40 Studio fixtures offer three different LED array choices based on specific white-light functions. The D40 Studio fixture is available with any one of the following arrays (not interchangeable) to best suit the intended application.

- D40 Studio HD – combines warm-white and cool -white LEDs for variable color temperature mixing. Added to this are five carefully chosen LED colors from the Selador x7 Color System™ to fill in the white LED spectral gaps. The high-intensity D40 Studio HD provides the richest variable-white light possible in an LED fixture and excellent color rendering
- D40 Studio Daylight – contains forty 5600K LEDs for high-intensity, non-variable cool-white output
- D40 Studio Tungsten – contains forty 3000K LEDs for high-intensity, non-variable warm-white output

ORDERING INFORMATION

Selador D40 Studio

MODEL	DESCRIPTION
SELD40HI	D40 Studio HD
SELD40DI	D40 Studio Daylight
SELD40TI	D40 Studio Tungsten

Note: D40 luminaires ship with a hanging yoke, a Very Narrow secondary lens and an input lead with a connector of choice. See page 2 for connector options. C-clamps are not included.

SELD40 H I - 0X

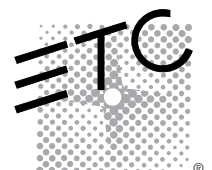
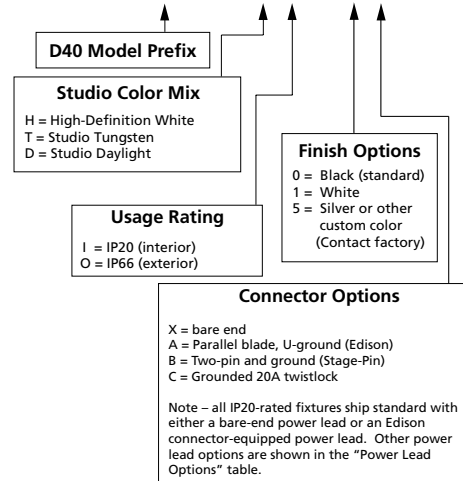

SPECIFICATIONS

GENERAL

- 40-LED variable white-light wash fixture
- ETL Listed to UL1573 – the standard for stage and studio lighting units
- IP20-rated for indoor use
- Power and DMX in/thru connections for easy setup
- User-friendly control interface with multiple modes and fixture settings

PHYSICAL

- Rugged die-cast all-metal housing
- Easy access slots for secondary lenses and standard 7.5" PAR accessories
- Available in black (standard), white or silver (optional) or custom colors (contact factory)
- Hanging yoke standard. Optional yoke/floor stand available

ELECTRICAL

- 100VAC to 240VAC 50/60 Hz universal power input
- Neutrik power in and thru connections
- Up to 10 fixtures (15A max) may be linked via power thru connector
- Requires power from a non-dim source
- Inrush
 - 120V / 15A
 - 240V / 40A

LED*

- 50,000-hour LED life (50,000 hours to 70% intensity)
- 40 Luxeon® Rebel LED emitters
- Studio Daylight and Studio Tungsten use Rebel ES white light emitters for higher output

*See additional LED notes on page three

COLOR

- Studio HD array uses warm and cool white-light emitters with additional deep-color emitters for variable white light with broad spectrum richness. It beautifully illuminates skin tones and other objects for natural appearance and high color rendering
- Studio Tungsten and Studio Daylight provide good color rendering at very high brightness

OPTICAL

- Primary field angle of 17°
- Secondary lenses available for multiple beam spread options
- Fixtures ship with a Very Narrow lens; additional lenses must be ordered separately
- Refer to accessories chart for lenses available

CONTROL

- DMX512 in and thru via five-pin XLR connectors
- Multiple control options including strobe and console-free Master/Slave mode
- See DMX Control Table for additional information
- 15-bit virtual dimming engine provides smooth, high-quality theatrical fades
- RDM functionality for address and setting changes

SPECIFICATIONS

THERMAL

- Ambient operating temperature of -4° to 104°F (-20° to 40°C)
- Active electronic thermal management for droop-free operation
- Noiseless, fan-free convection cooling for acoustically sensitive installations
- Fixture is designed for continuous operation up to 104°F (40°C) ambient temperature and requires free flow of air around fixture housing

ADDITIONAL ORDERING INFORMATION

Power Input Cables

Use information below to order 5' power input leads with factory-fitted connectors

MODEL	DESCRIPTION
DPA-A	5' PowerCon™ to parallel blade U-ground (Edison) connector
DPA-B	5' PowerCon to 20A two-pin and ground (stage pin) connector
DPA-C	5' PowerCon to grounded 20A twistlock connector
DPA-X	5' PowerCon to bare-end power input lead

Power Thru Jumpers

Note: Power thru jumpers connect to fixture's output (thru) connector to provide link to successive fixtures

MODEL	DESCRIPTION
DPJ-5	5' PowerCon to PowerCon fixture to fixture jumper
DPJ-10	10' PowerCon to PowerCon fixture to fixture jumper

Fixture Accessories

MODEL	DESCRIPTION
SELD40FSY	Yoke with floor-stand attachment
400BD	Barn door (Use only as a flexible top hat to diminish aperture glare. Not for beam shaping)
407CF	Color Frame (use for round and oblong lenses)
400L	Egg Crate Louver
400PTH3	Top Hat 3" Tube
400PTH6	Top Hat 6" Tube
400PHH	Half Hat 6" Tube
400CC	C-Clamp (does not ship with fixture)
400SC	Safety Cable (32")
DPSJ-25	25' PowerCon to Edison input power cable with inline switch

ADDITIONAL ORDERING INFORMATION

Secondary Lens Options

MODEL	DESCRIPTION: The following lenses are cut for D40 fixtures and create round, linear or oblong field patterns as described below. These lenses are not for use in Selador Classic™ fixtures.	
Narrow Linear Field	Note: This is the same material as Selador Classic lenses	
SELLVN-7.5	7.5" Very Narrow lens	Linear lenses may be combined to create desired field size
SELLN-7.5	7.5" Narrow lens	
SELLM-7.5	7.5" Medium lens	
SELLW-7.5	7.5" Wide lens	
SELLEW-7.5	7.5" Extra Wide lens	
Round Field		
SELRVN-7.5	7.5" Very Narrow lens (round field)	
SELRN-7.5	7.5" Narrow lens (round field)	
SELRM-7.5	7.5" Medium lens (round field)	
SELRW-7.5	7.5" Wide lens (round field)	
Oblong Field		
SELON-7.5	7.5" Narrow lens (oblong field)	
SELOM-7.5	7.5" Medium lens (oblong field)	
SELOW-7.5	7.5" Wide lens (oblong field)	

[http://www.etconnect.com/docs/docs_downloads/miscdocs/Desire vs PAR EA revB.pdf](http://www.etconnect.com/docs/docs_downloads/miscdocs/Desire_vs_PAR_EA_revB.pdf)

Typical Lens Field Profiles

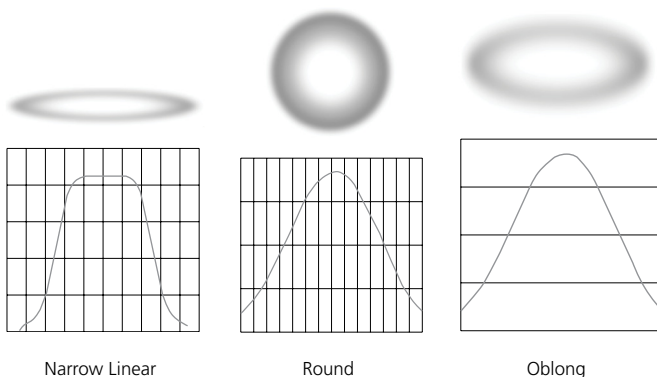

Power Consumption at Full Intensity

MODEL	VOLTAGE (V)	CURRENT (A)	WATTS
D40 Studio	120 / 240	1 / 0.5	110

NOTES ABOUT LED LUMINAIRES

All LED sources experience some lessening of light output and some color shift over time. LED output will vary with thermal conditions. Thermal conditions can be affected by ambient temperatures and orientation. See the D40 Ambient Temperature and Power Budgeting Guide for more details. Based on the LED manufacturer's B50 L70 specification, a Selador luminaire will achieve ~70% of its initial output after 50,000 hours of typical usage. In individual situations, LEDs will be used for different durations and at different levels. This can eventually lead to minor alterations in color performance, necessitating slight adjustments to presets, cues or programs.

CRI AND CQS RATINGS

Desire fixtures were evaluated for CRI and CQS performance using measured output spectrum and optimized mix solutions for a best spectral match to black body sources at 3200K and 5600K.

Fixture	CRI	CQS	Color Fidelity	Duv
D40 Vivid at 3200K	87	89	89	0.000
D40 Vivid at 5600K	90	92	92	0.000
D40 Lustr+ at 3200K	86	88	88	0.000
D40 Lustr+ at 5600K	93	92	90	0.000
D40 Studio HD at 3200K	89	90	91	0.000
D40 Studio HD at 5600K	92	94	94	0.000
D40 Studio Daylight at 5600K	71	70	69	0.001
D40 Studio Tungsten at 3000K	86	86	86	0.001

All D40 Studio luminaire versions provide excellent color rendering to the eye, particularly at higher color temperature settings such as 5600K. In most cases the Duv is 0.000. A Duv rating of 0.000 indicates that the color mix used is exactly on the black body line, with no green or magenta tint.

Notes to videographers:

- All Desire fixtures use Luxeon Rebel ES emitters specified by the strictest binning standards. However, on-camera LED response varies with different cameras and settings. Daylight LEDs can appear slightly greener than other 5600K sources on camera.
- Fixtures with non-variable single-color daylight arrays, such as Studio Daylight, may use standard color correction filters (Rosco 3314, Rosco 3316 or similar) to achieve the desired on-camera result.
- Camera tests using your specific setup are recommended to determine the best configuration.

CONTROL OPTIONS

Studio HD

User settings on D40 Studio fixtures allow multiple operational modes and settings for either console operation via DMX protocol or stand-alone operation. The expanded LCD display provides easy navigation to all possible settings and options. Some of the setting options are:

- Multiple DMX choices ranging from a simple RGB profile – which effectively controls all seven LED colors via three channels – to nine-channel direct color and intensity control
- Multiple dimming curve options
- Preset colors and sequences for stand-alone (no console required) operation
- White point selection – white light and color behavior based on a specific color-temperature white light, i.e. 3200K, 5600K, etc.
- Loss of data behavior options – instant off, hold last look for two minutes, etc.
- Output modes – three output options that offer the user a choice between maximum output and maximum consistency

See the user manual for a complete explanation of all of the control settings and options for the D40 Studio.

Quick Setups

To assist in managing the numerous control and fixture behavior choices, five combinations of operational settings are available to quickly get started. These settings are specifically created for different applications and are easily accessible at the fixture display. Each setting can then be modified as required to take advantage of all of the possible control features.

Setting Title	Profile	Description	Typical Features*
Studio	Studio	Studio factory default: Enables three-parameter control of white light (intensity, white point, and tint) via DMX from a console or console-free from a fixture display	<ul style="list-style-type: none"> • Linear dimming curve • Regulated output mode for color consistency
General	Direct	For general-purpose use, including interior architectural applications	<ul style="list-style-type: none"> • Standard dimming curve • Regulated output for color consistency • 3200K white-point setting
Stage	HSI Plus 7 Enabled	Theatrical lighting: Duplicates the color and dimming behavior of tungsten stage lighting fixtures	<ul style="list-style-type: none"> • Incandescent dimming curve • Regulated output for color consistency • 3200K white-point setting
XT Arch	HSI	Exterior architectural lighting: Provides a high degree of color consistency in high ambient-temperature environments	<ul style="list-style-type: none"> • Standard dimming curve • Protected output • 3200K white-point setting
Hight Impact	RGB	Event lighting: Enables quickest response, simple RGB control and strobe channel for maximum effect usage	<ul style="list-style-type: none"> • Quick dimming curve • Boost mode for maximum intensity • 5600K white-point setting

*See user manual for complete list of features for each Quick Setup

CONTROL OPTIONS

Studio HD

DMX Input Channel Profiles

DMX Profile	DMX Channels	Channel Assignments	Notes
Studio	3	1 – Intensity 2 – Color Point (CCT) 3 – Tint	Controls fixture as a white light unit. If no DMX is present (console input, for example), fixture can be adjusted for these three parameters on the user interface at the back of the unit
Direct	9	1 – Red 2 – Orange 3 – Amber 4 – Green 5 – 3000K White 6 – 5700K White 7 – Indigo 8 – Intensity 9 – Strobe	Direct control of each individual color with a separate master intensity channel. Color calibration of LEDs is not active in this mode. The nine-channel profile will produce the highest-quality color crossfades
HSI	5	1 – Hue (coarse) 2 – Hue (fine) 3 – Saturation 4 – Intensity 5 – Strobe	High-resolution hue (two channels), saturation, and intensity control. HSI mode will produce color crossfades around the color space
HSIC	6	1 – Hue (coarse) 2 – Hue (fine) 3 – Saturation 4 – Intensity 5 – Strobe 6 – Color Point (CCT)	High-resolution hue, saturation and intensity control as above, with the addition of a color-point channel to adjust the color temperature of the fixture in both white light and color. Color crossfade performance is the same as HSI
RGB	5 (Ch. 4 not used)	1 – Red 2 – Green 3 – Blue 4 – n/a 5 – Strobe	Effectively addresses all seven colors via three channels of control. RGB profile will produce medium-quality color crossfades

Additional profile options

Plus 7	Seven additional color control channels are available in RGB, HSI, HSIC, and Studio profile settings. For example, HSI with 'Plus 7' enabled becomes a 14-channel profile:		
	1 – Hue (coarse) 2 – Hue (fine) 3 – Saturation 4 – Intensity 5 – Strobe 6 – n/a 7 – Plus 7 Control on/off 8 – Red 9 – Orange 10 – Amber 11 – Green 12 – Cyan 13 – Blue 14 – Indigo	The desired color and intensity are achieved by using the HSI or RGB channels. Placing channel seven at a value over 51% gives the fixture a 14-channel profile. Channels 8-14 represent the native colors of the fixture and allow the operator to adjust individual color channels to fine tune the color output.	
Strobe	Variable strobe control: 0% is no strobe. The fixture output will strobe more rapidly as the strobe channel value approaches 100%.		

CONTROL OPTIONS

Studio Daylight and Studio Tungsten only

Quick setups

Setting Title	Profile	Description	Typical Features
Studio	Studio	Enables control of intensity from luminaire's user interface; no console required	<ul style="list-style-type: none"> • Linear dimming curve • Regulated output for intensity stability
Single Channel	Direct	For general-purpose architectural use	<ul style="list-style-type: none"> • Standard dimming curve • Regulated output for color consistency
Stage	Direct	Matches conventional luminaire performance	<ul style="list-style-type: none"> • Incandescent dimming curve • Regulated output

DMX input channel profiles

DMX Profile	DMX Channels	Channel Assignments	Notes
Studio	3	1 – Intensity 2 – Strobe 3 – Fan Control	Control of parameters is also enabled from the luminaire's user interface. No console required.
Direct	3	1 – Intensity 2 – Strobe 3 – Fan Control	

PHOTOMETRICS

D40 Studio HD

Mode	Degree	Candela	Field Lumens	Beam Lumens	Lumens Per Watt
Boost - Cold	17°	132,120	2,983	1,347	28.8
Regulated	17°	124,663	2,794	1,253	28.4
Regulated 3200K	18°	82,881	2,022	832	29.6
Regulated 5600K	17°	88,412	1,969	889	28.5

Metric Conversions: For meters, multiply feet by 0.3048
For lux, multiply footcandles by 10.76

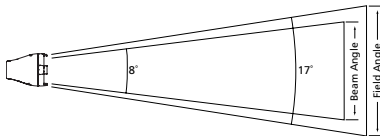

Throw Distance (d)	10.0'	15.0'	20.0'	25.0'	353.1'
	3.0m	4.6m	6.1m	7.6m	107.6m
Field Diameter	3.0'	4.4'	5.9'	7.4'	104.7'
	0.9m	1.4m	1.8m	2.3m	31.9m
Illuminance (fc)	1,247	554	312	199	1
Illuminance (lux)	13,419	5,964	3,355	2,147	10.76

For field diameter at any distance, multiply distance by 0.313
For beam diameter at any distance, multiply by 0.143

Cosine Candela Plot

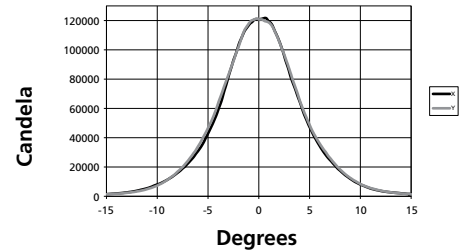

Iso-Illuminance Diagram (Flat Surface Distribution)

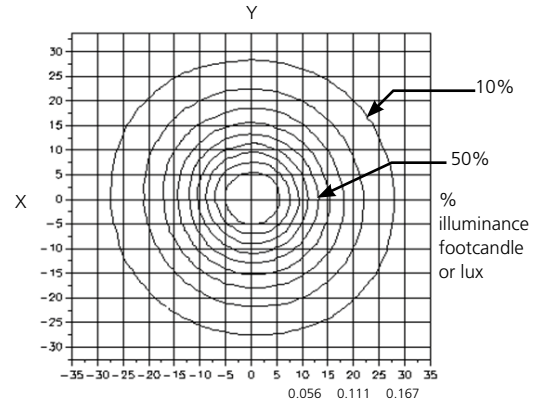

D40 Studio Daylight

Mode	Degree	Candela	Field Lumens	Beam Lumens	Lumens Per Watt
Boost - Cold	22°	137,140	5,378	2,582	53.5
Regulated	22°	126,098	4,953	2,352	52.9

Metric Conversions: For Meters multiply feet by 0.3048
For Lux multiply footcandles by 10.76

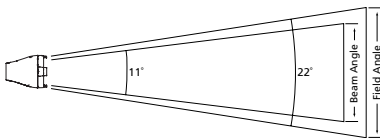

Throw Distance (d)	10'	15'	20'	25'	353.1'
	3.0m	4.6m	6.1m	7.6m	107.6m
Field Diameter	3.0'	4.4'	5.9'	7.4'	104.7'
	0.9m	1.4m	1.8m	2.3m	31.9m
Illuminance (fc)	1,247	554	312	199	1
Illuminance (lux)	13,419	5,964	3,355	2,147	10.76

For field diameter at any distance, multiply distance by 0.390
For beam diameter at any distance, multiply by 0.198

Cosine Candela Plot

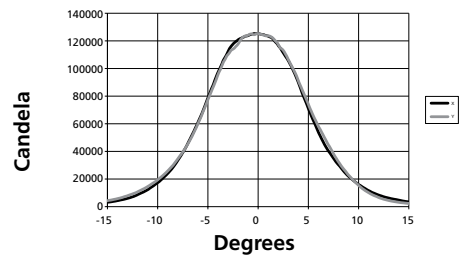

Iso-Illuminance Diagram (Flat Surface Distribution)

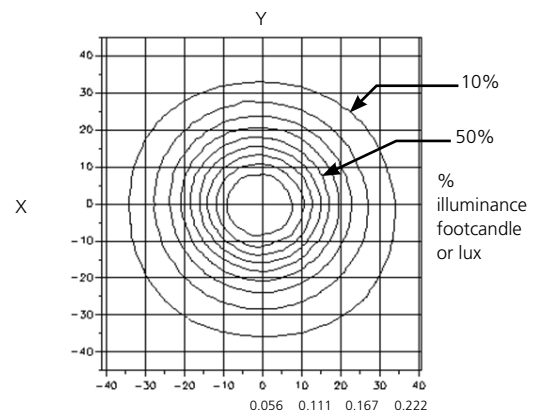

PHOTOMETRICS

D40 Studio Tungsten

Mode	Degree	Candela	Field Lumens	Beam Lumens	Lumens Per Watt
Boost - Cold	23°	108,066	4,123	1,871	39.2
Regulated	23°	102,835	3,924	1,796	38.6

Metric Conversions: For meters, multiply feet by 0.3048
 For lux, multiply footcandles by 10.76

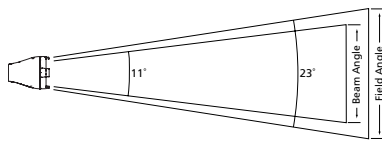

Throw Distance (d)	10.0'	15.0'	20.0'	25.0'	320.7'
	3.0m	4.6m	6.1m	7.6m	97.7m
Field Diameter	3.8'	5.7'	7.6'	9.6'	122.6'
	1.2m	1.7m	2.3m	2.9m	37.4m
Illuminance (fc)	1,028	457	257	165	1
Illuminance (lux)	11,069	4,920	2,767	1,771	10.76

For field diameter at any distance, multiply distance by 0.414
 For beam diameter at any distance, multiply by 0.189

Throw Distance Multiplier (TDM)

To determine the distance from the center of the beam (Origin) to a certain illuminance level at a particular distance, multiply the desired throw distance by the TDM desired on the Iso-Illuminance diagram.

Throw Distance (TD) x Throw Distance Multiplier (TDM) = Distance from the Origin (DfO) (distance from the center of the beam)

Example: 25 feet (TD) x 0.047 (TDM) = 1.175 feet from center of beam (DfO)

For illumination with any lamp, multiply the candlepower of a beam spread by the multiplying factor (mf) shown for that lamp.

To determine illumination in footcandles or lux at any throw distance, divide candlepower by distance squared.

Cosine Candela Plot

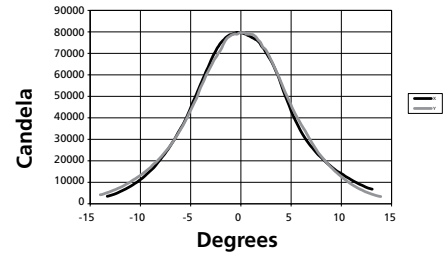

Iso-Illuminance Diagram (Flat Surface Distribution)

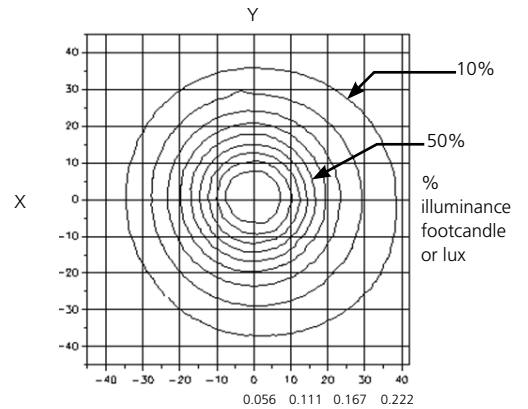

PHYSICAL

Selador Desire D40 Studio Weights and Dimensions

WEIGHT*		SHIPPING WEIGHT	
lbs	kgs	lbs	kgs
14	6.4	17	7.8

* Does not include mounting hardware

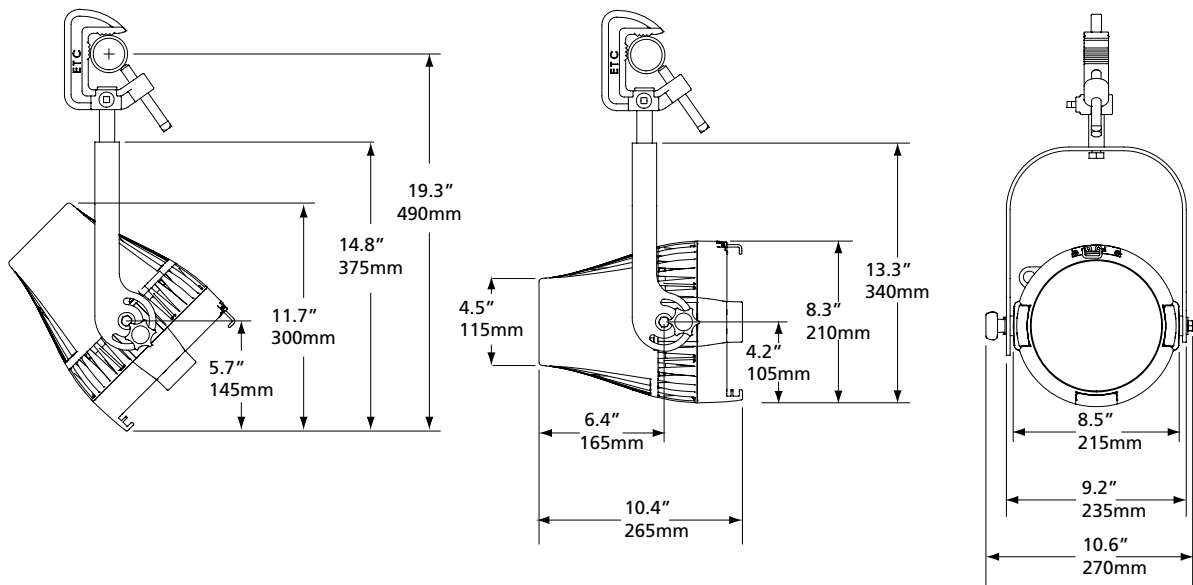

Corporate Headquarters • 3031 Pleasant View Rd, PO Box 620979, Middleton WI 53562 0979 USA • Tel +1 608 831 4116 • Fax +1 608 836 1736
London, UK • Unit 26-28, Victoria Industrial Estate, Victoria Road, London W3 6UU, UK • Tel +44 (0)20 8896 1000 • Fax +44 (0)20 8896 2000
Rome, IT • Via Pieve Torina, 48, 00156 Rome, Italy • Tel +39 (06) 32 111 683 • Fax +44 (0)20 8752 8486
Holzkirchen, DE • Ohmstrasse 3, 83607 Holzkirchen, Germany • Tel +49 (80 24) 47 00-0 • Fax +49 (80 24) 47 00-3 00
Hong Kong • Room 1801, 18/F, Tower 1 Phase 1, Enterprise Square, 9 Sheung Yuet Road, Kowloon Bay, Kowloon, Hong Kong • Tel +852 2799 1220 • Fax +852 2799 9325
Web • www.etconnect.com • Copyright©2014 ETC. All Rights Reserved. All product information and specifications subject to change. 7410L1002 Rev. M USA 03/14

This product is protected by one or more of the following U.S. Patents: 6,016,038, 6,150,774, 6,788,011, 6,806,659, 6,683,423 and 7,023,543