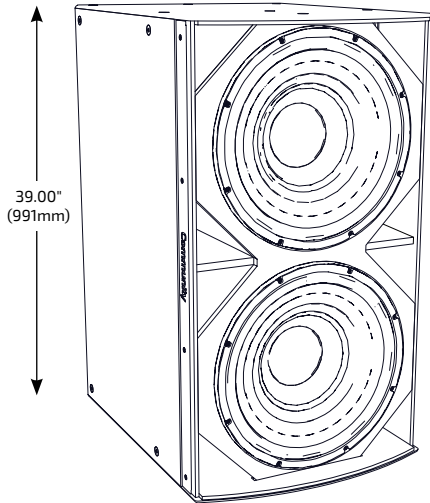

I SERIES

Subwoofer 600

IS6-218

 MEDIUM POWER DUAL 18-INCH
SUBWOOFER

APPLICATIONS
SMALL TO MEDIUM SIZE VENUES

 Houses of Worship · Auditoriums · Restaurants
Meeting Rooms · Corporate A/V Systems

LARGER SIZE VENUES

 Arenas · Stadiums · Night Clubs · Theaters
Themed Entertainment · Larger Houses of Worship

DESCRIPTION

I SERIES Subwoofer 600 loudspeakers provide exemplary acoustic performance, modular flexibility and elegant aesthetics for modern performance venues. Designed to support the goals of systems integrators and consultants both acoustically and mechanically, I SERIES Subwoofers provide a broad range of sizes and capabilities that can be specifically matched to the needs of any modern venue.

Each cabinet was carefully designed to provide matching heights, face widths and suspension point locations for seamless integration into flown arrays with I SERIES full-range models. The broad range of optional low profile fly rails, fly frames and modular array brackets reduces design and installation time while also providing improved aesthetics and nearly limitless integration possibilities.

The IS6-218 is a direct radiating subwoofer with large, balanced ports that provide optimal enclosure tuning and even air pressure distribution to the driver cones, reducing distortion and extending system longevity. Drivers are loaded into individual air volumes within the enclosure, isolating their performance from one another. This arrangement not only provides additional protection to drivers in case of failures, but also allows the designer to implement directional subwoofer techniques, like steered end-fire arrays and cardioid patterns, within a single enclosure when using any I SERIES dual driver subwoofer model.

FEATURES

- Long excursion ferrite LF drivers with FEA-optimized motors and symmetric movement suspension
- Matched-size enclosure and aligned suspension point for seamless flown array integration
- 1400W continuous power handling (5600W peak)
- High sensitivity design minimizes power compression losses and required amplifier size
- Isolated driver air volumes allow use of directional steering techniques within a single enclosure

TECHNICAL SPECIFICATIONS¹

Operating Mode	Single or Dual Amp		
Operating Environment	Indoor		
Operating Range²	32 Hz to 145 Hz		
Transducers	2 x 18" (457mm) double-treated cones with 4" (102mm) inner/outer wound voice coil, ferrite construction		
Continuous Power Handling³ @ Nominal Impedance	Single Amp	75V	1400W @ 4 ohms (5600W peak)
	Dual Amp	75V	700W @ 8 ohms (2800W peak) (each)
Nominal Sensitivity⁴	Half Space	@ 1W 107 dB	@ 2.83V 110 dB
	Whole Space	101 dB	104 dB
Nominal Maximum SPL⁵	Half Space	Peak 144 dB	Continuous 138 dB
	Whole Space	138 dB	132 dB
Equalized Sensitivity⁶	Half Space	@ 1W 102 dB	@ 2.83V 105 dB
	Whole Space	96 dB	99 dB
Equalized Maximum SPL⁷	Half Space	Peak 139 dB	Continuous 133 dB
	Whole Space	133 dB	127 dB
Recommended Amplifiers	Single Amp	1400W - 2800W @ 4 ohms, (75V - 106V)	
	Dual Amp	700W - 1400W @ 8 ohms, (75V - 106V) (each driver)	

PHYSICAL

Input Connection	(2) 4 position screw terminal blocks
Mounting Points	(24) M10 threaded rigging points
Environmental	IPX4 per IEC 60529 , designed in accordance with MIL-STD-810G
Dimensions/Weight/Finish	Refer to the Technical Drawing

OPTIONS

Accessories (Refer to Accessory Guide for complete listing)	Modular rigging kits include: BFR38 : BalancePoint™ Fly Rails; IAF55 : Isometric Array Frame; VAB-BFR38 : Sub Above Vert. Array; HAB : Sub/Dual 2-Way Horiz. Array; HVS : Multiple Horiz./Vert. Array Kits with Sub Behind Array options; TPK : Tight Pack Kit
Configure-to-Order (CTO)	Custom color

IS6-218 MEDIUM POWER DUAL 18-INCH SUBWOOFER

AXIAL PROCESSED RESPONSE (dB)⁸

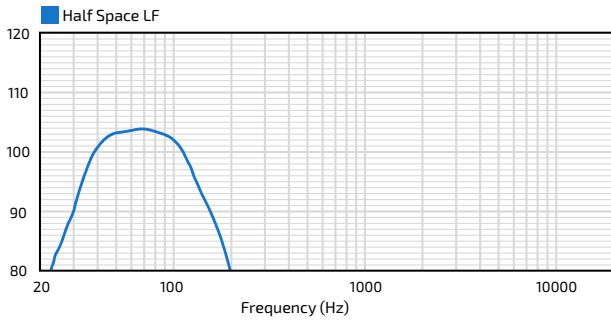

AXIAL SENSITIVITY (dB SPL)⁹

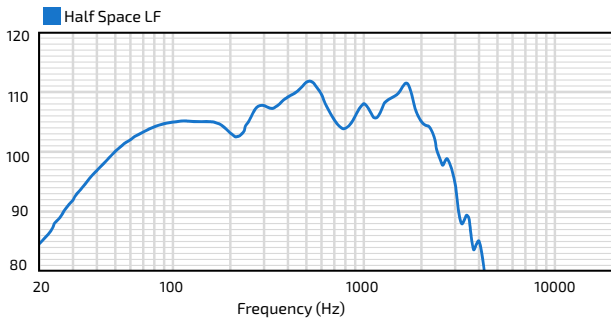

IMPEDANCE (Ohms)

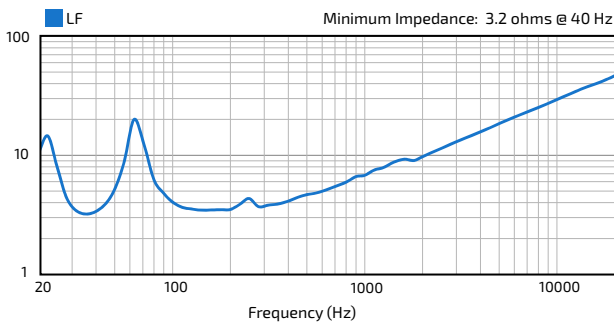

IS6-218 MEDIUM POWER DUAL 18-INCH SUBWOOFER

TECHNICAL DRAWING / DIMENSIONS / FINISH

H x W x D
39.00" x 22.10" x 28.89"
(991 x 561 x 734 mm)

Unit Weight

170 lbs (77.1 kg) loudspeaker only

Shipping Weight

190 lbs (86.2 kg)

Grille:

Powder-coated perforated steel backed with color-matched acoustically transparent woven fabric
Black (RAL#9005) or White (RAL#9003)

Enclosure / Finish

Black (RAL#9004) or White (RAL#9003)
low gloss, uniformly textured painted
15mm Baltic Birch plywood

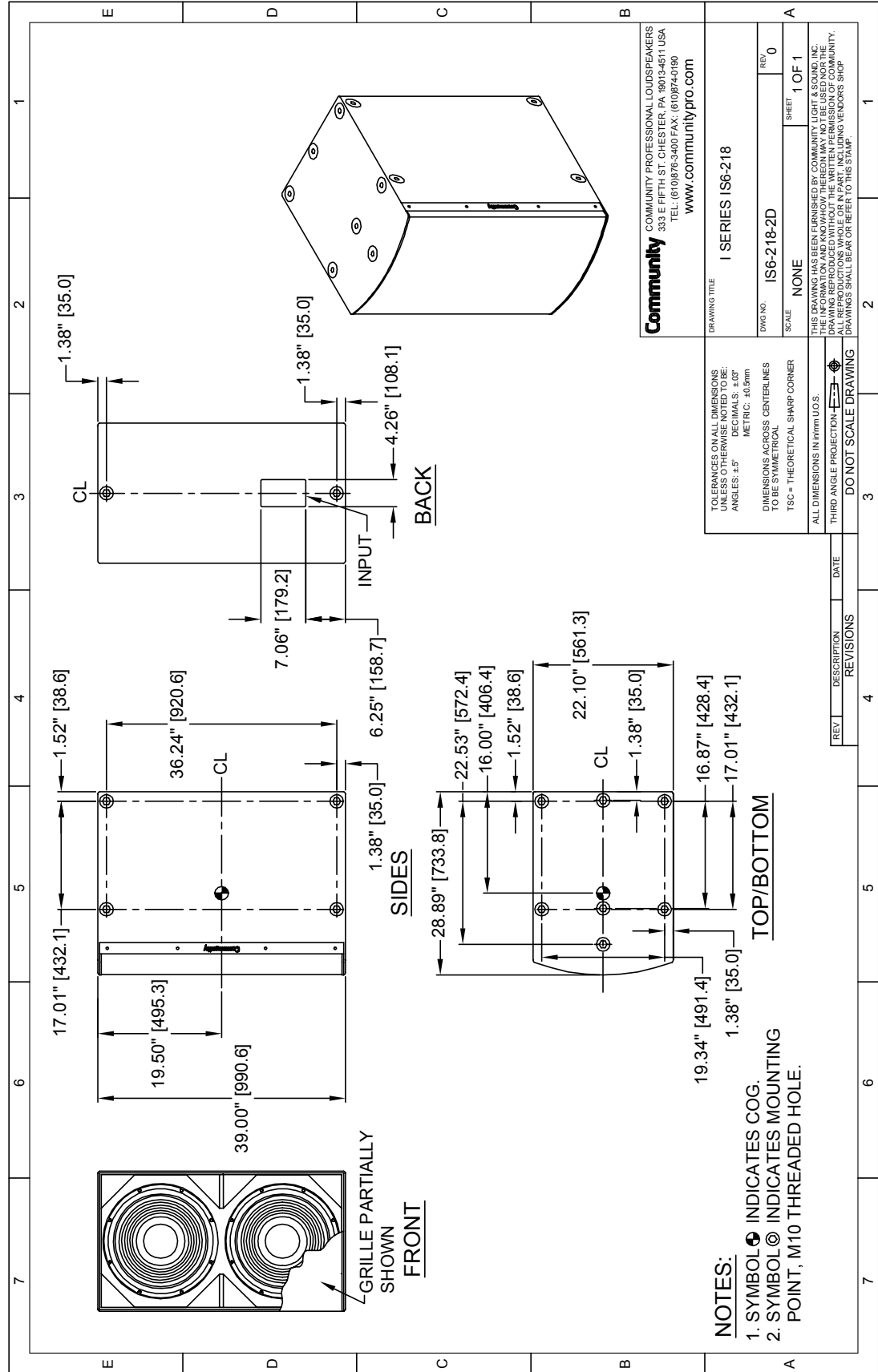

- NOTES:**
1. SYMBOL INDICATES COG.
 2. SYMBOL INDICATES MOUNTING POINT, M10 THREADED HOLE.

I SERIES

Subwoofer 600

IS6-218

MEDIUM POWER DUAL 18-INCH
SUBWOOFER

CONNECTION DIAGRAMS

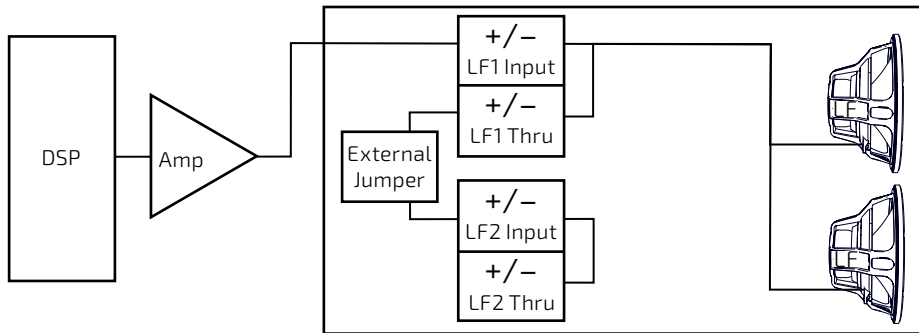

Single amp

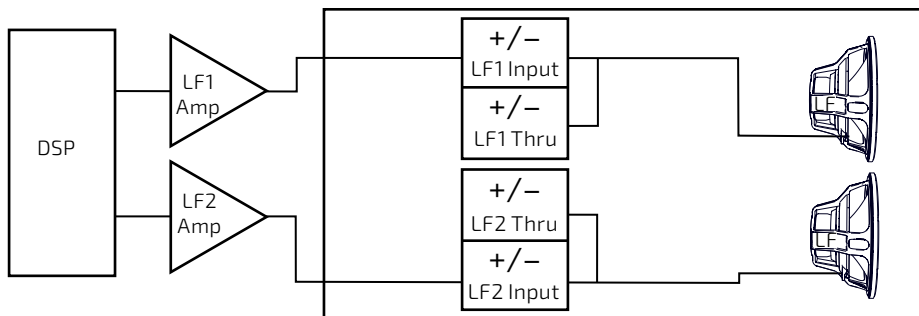

Dual amp

INPUT PANEL

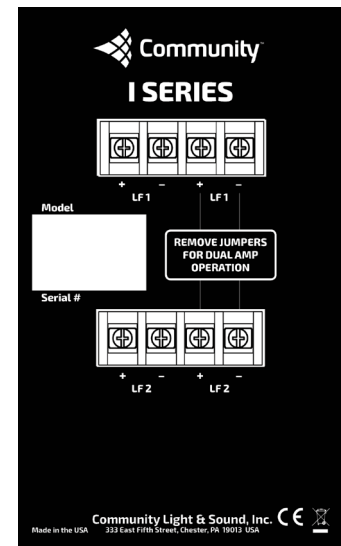

NOTES

- PERFORMANCE SPECIFICATIONS** All measurements are taken indoor using a time-windowed and processed to eliminate room effects, approximating an anechoic environment, a distance of 6.0 m. All acoustic specifications are rounded to the nearest whole number. An external DSP with settings provided by Community Professional Loudspeakers is required to achieve the specified performance; further performance gains can be realized using Community's dSPEC226 loudspeaker processor with FIR power response optimization.
- OPERATING RANGE** The frequency range in which the axial processed response remains within 10dB of the average SPL.
- CONTINUOUS POWER HANDLING** Maximum continuous input voltage (and the equivalent power rating, in watts, at the stated nominal impedance) that the system can withstand, without damage, for a period of 2 hours using an EIA-426-B defined spectrum; with recommended signal processing and protection filters.
- NOMINAL SENSITIVITY** Averaged SPL over the operating range with an input voltage that would produce 1 Watt at the nominal impedance and the averaged SPL over the operating range with an input voltage of 2.83 Volts, respectively; swept sine wave axial measurements with no external processing applied in whole space, except where indicated.
- NOMINAL MAXIMUM SPL** Calculated based on nominal / peak power handling, respectively, and nominal sensitivity; exclusive of power compression.
- EQUALIZED SENSITIVITY** The respective SPL levels produced when an EIA-426-B signal is applied to an equalized loudspeaker system at a level which produces a total power of 1 Watt, in sum, to the loudspeaker subsections and at a level which produces a total voltage, in sum, of 2.83 volts to the loudspeaker subsections, respectively; each referenced to a distance of 1 meter.
- EQUALIZED MAXIMUM SPL** The SPL produced when an EIA-426-B signal is applied to an equalized loudspeaker system, at a level which drives at least one subsection to its rated continuous input voltage limit, referenced to a distance of 1 meter. The peak SPL represents the 2:1 (6dB) crest factor of the EIA-426-B test signal.
- AXIAL PROCESSED RESPONSE** The axial magnitude response of the complete loudspeaker system and each pass band capable of being driven by an independent amplification channel with recommended signal processing applied. 1/6 octave smoothing applied.
- AXIAL SENSITIVITY** The SPL plotted against frequency, in all operating modes and for each pass band capable of being driven by an independent amplification channel, for a 1 Watt swept sine wave, referenced to 1 meter with no signal processing. 1/6 octave smoothing applied.

Data presented on this spec sheet represents a selection of the basic performance specifications for the model. These specifications are intended to allow the user to perform a fair, straightforward evaluation and comparison with other loudspeaker spec sheets. For a detailed analysis of this loudspeaker's performance, please download the GLL file and/or the CLF file from our website: communitypro.com.

Community Professional Loudspeakers
333 East Fifth Street, Chester, PA 19013-4511 USA
Phone (610) 876-3400 • Fax (610) 874-0190
communitypro.com • info@communitypro.com

CAUTION: Installation of loudspeakers should only be performed by trained and qualified personnel. It is strongly recommended that a licensed and certified professional structural engineer approve the mounting design.