

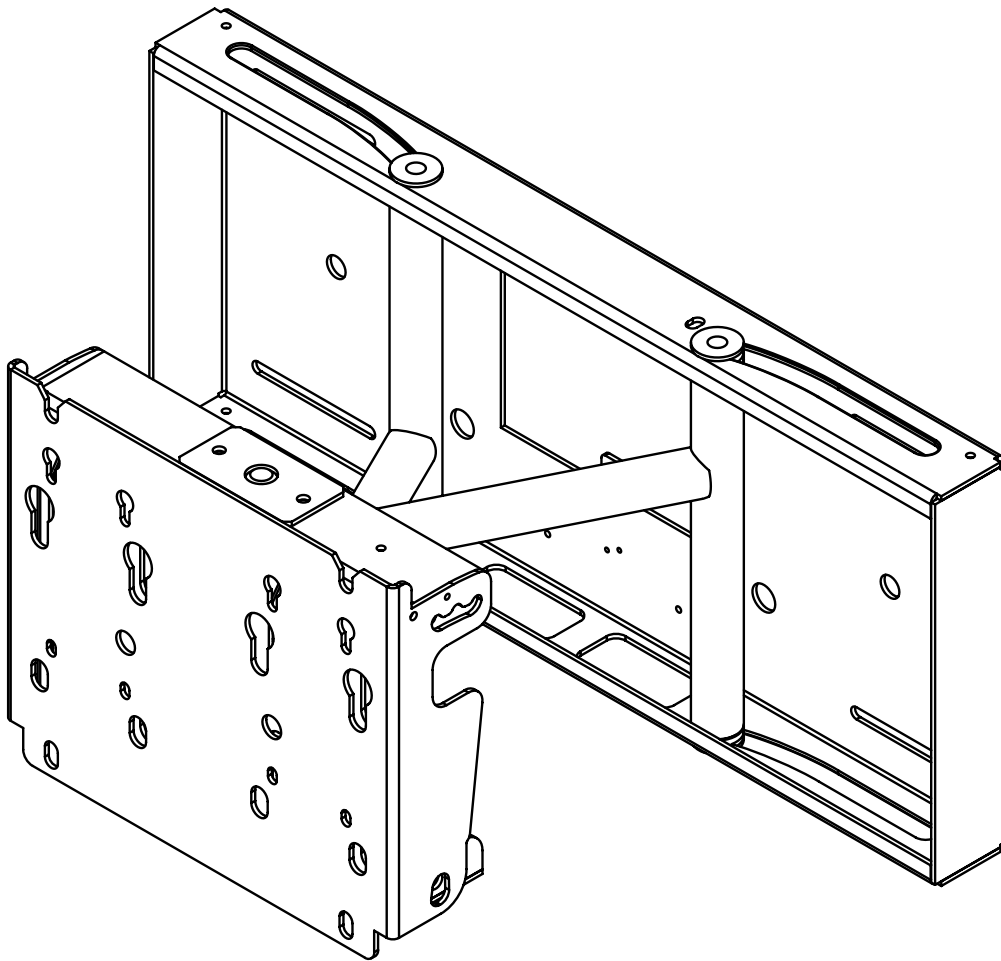

Installation and Assembly: Flat Panel Pull-out Swivel Wall Mount

Models: SP850-V2X2



Note: Read entire instruction sheet before you start installation and assembly.

▲ WARNING

- Do not begin to install your Peerless product until you have read and understood the instructions and warnings contained in this Installation Sheet. If you have any questions regarding any of the instructions or warnings, for US customers please call Peerless customer care at 1-800-865-2112, for all international customers, please contact your local distributor.
- This product should only be installed by someone of good mechanical aptitude, has experience with basic building construction, and fully understands these instructions.
- Make sure that the supporting surface will safely support the combined load of the equipment and all attached hardware and components.
- Never exceed the Maximum Load Capacity. See page one.
- If mounting to wood wall studs, make sure that mounting screws are anchored into the center of the studs. Use of an "edge to edge" stud finder is highly recommended.
- Always use an assistant or mechanical lifting equipment to safely lift and position equipment.
- Tighten screws firmly, but do not overtighten. Overtightening can damage the items, greatly reducing their holding power.
- This product is intended for indoor use only. Use of this product outdoors could lead to product failure and personal injury.
- This product was designed to be installed on the following wall construction only;

WALL CONSTRUCTION

HARDWARE REQUIRED

- | | |
|--------------------|--|
| • Wood Stud | Included |
| • Wood Beam | Included |
| • Solid Concrete | Included |
| • Cinder Block | Included |
| • Metal Stud | Do not attach except with Peerless Metal Stud Accessory Kit
- ACC415; |
| • Brick | Contact Qualified Professional |
| • Other or unsure? | Contact Qualified Professional |

Tools Needed for Assembly

- stud finder ("edge to edge" stud finder is recommended)
- 3/8" socket wrench (3/8" extended driver is recommended)
- phillips screwdriver
- drill
- 5/16" bit for concrete and cinder block wall
- 5/32" bit for wood stud wall
- level
- 6 mm allen wrench (if attaching to PLP models)

Table of Contents

Parts List.....	3
Installation to Wood Stud Wall.....	4
Installation to Solid Concrete and Cinder Block	5
Mounting Flat Panel Screen with VESA hole pattern	6,7
Mounting Flat Panel Screen with Peerless PLP model adapter plate (PLP adapter plates are not UL listed)	7

Parts List

Description	Qty.	Part #
A wall mount assembly	1	201-1967
B locking tab	1	200-1871
C .219 ID x .5 OD x .125H spacer	1	540-1032
D #14 x 2-1/2" hex head wood screw	4	551-015-C03
E concrete anchor	4	590-0320
F 18" polyester mesh sleeve	2	600-1014
G cable tie	4	560-9711
H M10 x 15 mm socket head screw	4	520-9262
I .198 x .313 x .437H retaining spacer	4	590-5005
J 4 mm security allen wrench	1	560-1146
AA M5 x 10 mm socket pin screw	5	520-1063
BB M4 x 12 mm socket pin screw	4	510-1079
CC M4 x 20 mm socket pin screw	4	510-1061
DD M5 x 40 mm socket pin screw	1	510-1001
EE 1/4" flat washer	4	540-9440
FF M6 x 12 mm socket pin screw	4	520-1050
GG M8 x 15 mm socket pin screw	4	520-1068

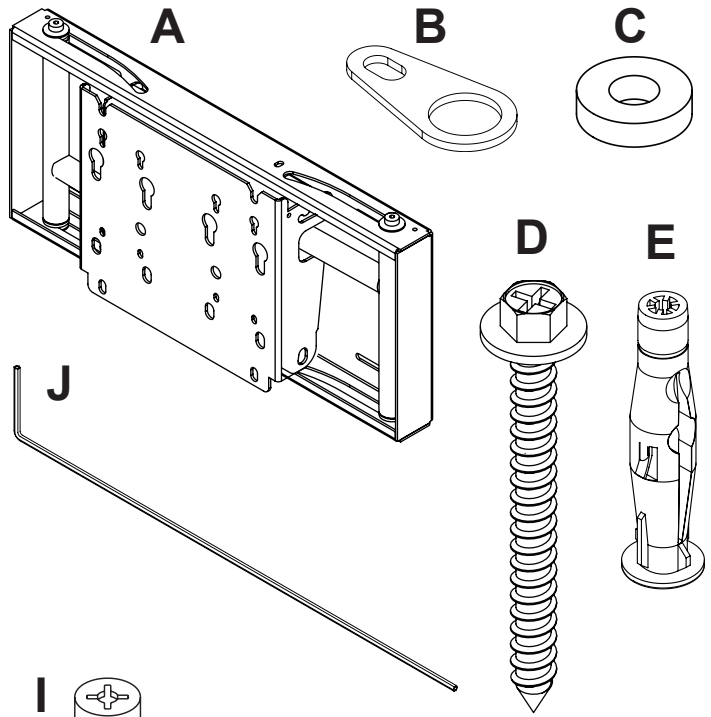

Some parts may appear slightly different than illustrated.

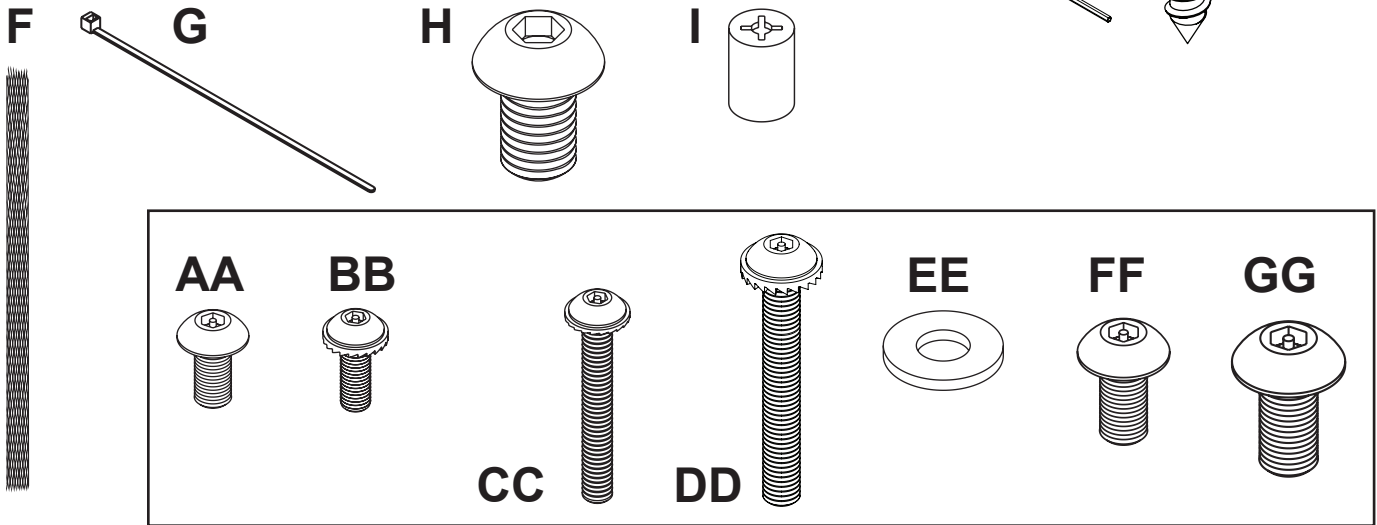

1 Snap installation tab off of wall mount assembly (A).

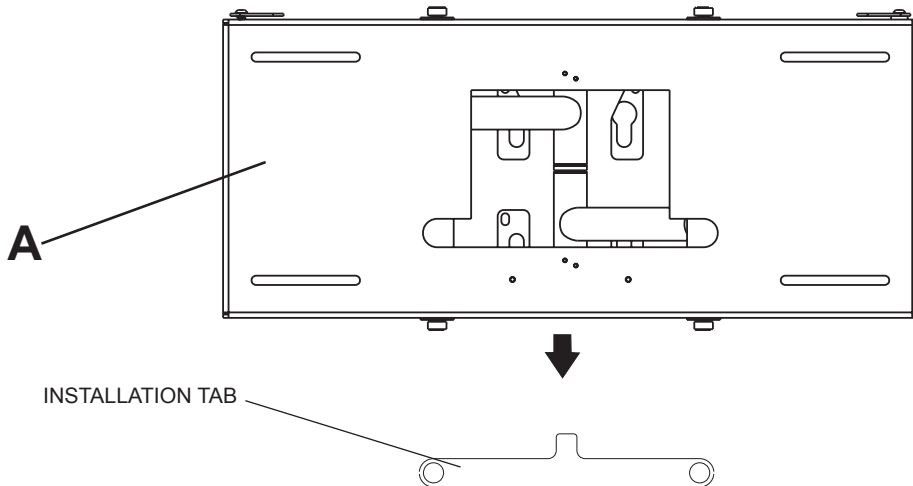

Installation to Wood Stud Wall

⚠ WARNING

- Installer must verify that the supporting surface will safely support the combined load of the equipment and all attached hardware and components.
- Tighten wood screws so that wall plate is firmly attached, but do not overtighten. Overtightening can damage the screws, greatly reducing their holding power.
- Never tighten in excess of 80 in. • lb (9 N.M.).
- Make sure that mounting screws are anchored into the center of the stud. The use of an "edge to edge" stud finder is highly recommended.
- Hardware provided is for attachment of mount through standard thickness drywall or plaster into wood studs. Installers are responsible to provide hardware for other types of mounting situations.

2 Using a stud finder, locate the edges of the wood studs used in mounting this product. Use of an edge-to-edge stud finder is highly recommended. Based on its edges and using a level, draw a vertical line down the center of each stud. Mark a point (**point 1**) on the right stud centerline where upper right slot will be located. Using a level, mark a point (**point 2**) on the left stud centerline level with point 1 as shown in figure 2.1. Drill $\frac{5}{32}$ " diameter holes 2-1/2" deep through studs at the two points. Loosely fasten wall mount assembly (**A**) to wall using two #14 x 2-1/2" wood screws (**D**) as shown in figure 2.2. Level, hold, and then tighten screws.

Mark two more points for bottom slots on the right and left stud centerlines. Drill $\frac{5}{32}$ " diameter holes 2-1/2" deep through studs at the two points. Using two #14 x 2-1/2" wood screws, fasten bottom of wall mount assembly to wall as shown in figure 2.3.

Skip to step 3 on page 6.

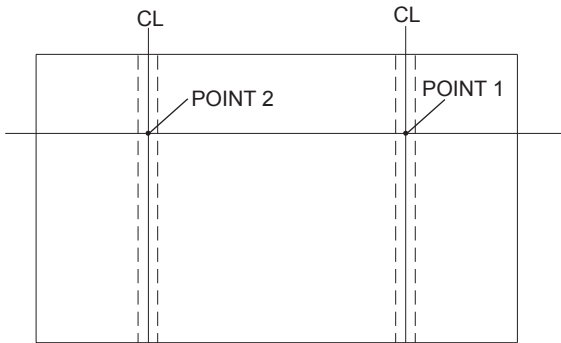

fig 2.1

CL = stud centerline

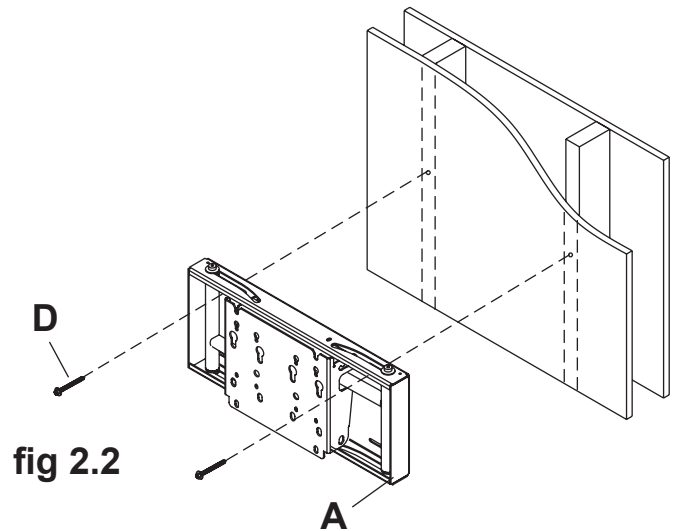

fig 2.2

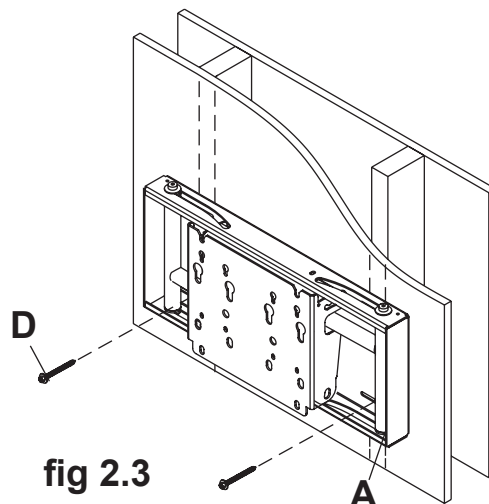

fig 2.3

Installation to Solid Concrete and Cinder Block Wall

⚠ WARNING

- When installing Peerless wall mounts on cinder block, verify that you have a minimum of 1-3/8" of actual concrete thickness in the hole to be used for the concrete anchors. Do not drill into mortar joints! Be sure to mount in a solid part of the block, generally 1" minimum from the side of the block. Cinder block must meet ASTM C-90 specifications. It is suggested that a standard electric drill on slow setting is used to drill the hole instead of a hammer drill to avoid breaking out the back of the hole when entering a void or cavity.
- Concrete must be 2000 psi density minimum. Lighter density concrete may not hold concrete anchor.
- Make sure that the supporting surface will safely support the combined load of the equipment and all attached hardware and components.

2 Position wall mount assembly (A) at desired position on wall. Use wall mount assembly, making sure that it is level, as a template to mark holes. Drill four 5/16" (8mm) dia. holes to a minimum depth of 2-1/2" (64 mm). Concrete must be 2000 psi density minimum. Insert anchors (E) in holes flush with wall as shown in figure 2.4. Place wall mount assembly over anchors and secure with #14 x 2-1/2" wood screws (D) as shown in figure 2.5. Make sure wall plate is level and tighten all fasteners.

⚠ WARNING

- Tighten wood screws so that wall plate is firmly attached, but do not overtighten. Overtightening can damage screws, greatly reducing their holding power.
- Never tighten in excess of 80 in • lb (9 N.M.).

⚠ WARNING

- Always attach concrete expansion anchors directly to load-bearing concrete.
- Never attach concrete expansion anchors to concrete covered with plaster, drywall, or other finishing material. If mounting to concrete surfaces covered with a finishing surface is unavoidable, the finishing surface must be counterbored as shown below. If plaster/drywall is thicker than 5/8", custom fasteners must be supplied by installer.

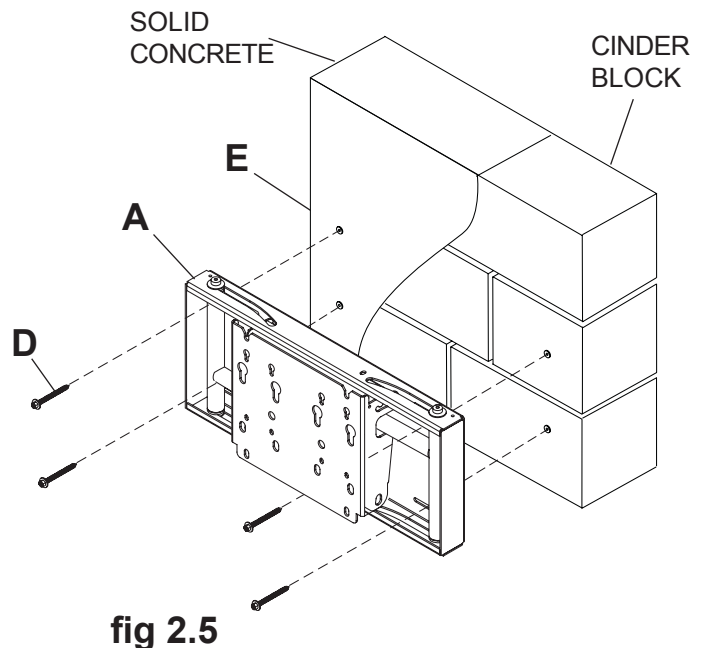
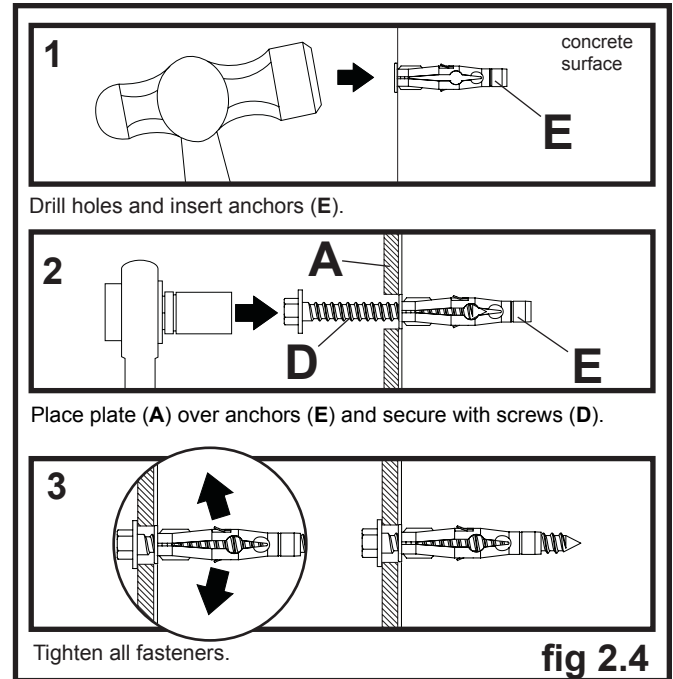
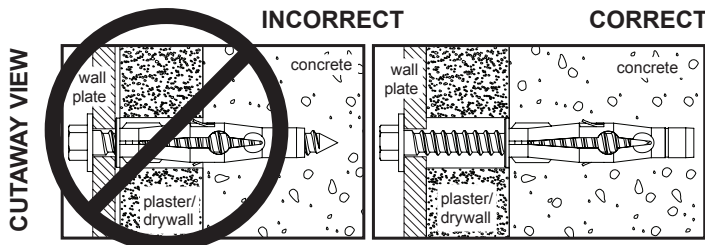

3 Place installation tab over sliding arms of wall mount assembly (**A**) to lock them in place.

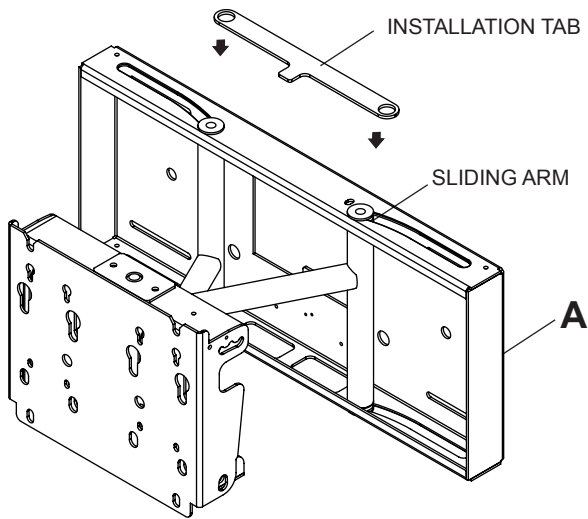

⚠ WARNING

- If screws don't get three complete turns in the screen inserts or if screws bottom out and adapter plate is still not tightly secured, damage may occur to screen or product may fail. Contact customer care for correct hardware to use.

4 Find the VESA® hole pattern as shown below, and attach screen to mounting plate as specified below. Verify that all holes are properly aligned, and then tighten screws. If using security screws, tighten using security allen wrench (**M**).

VESA 100 x 100

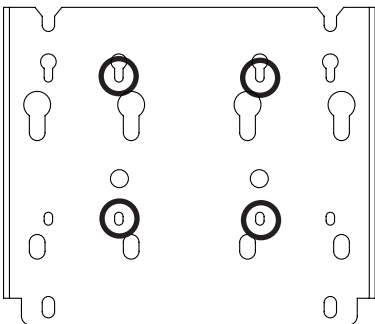

VESA 200 x 100

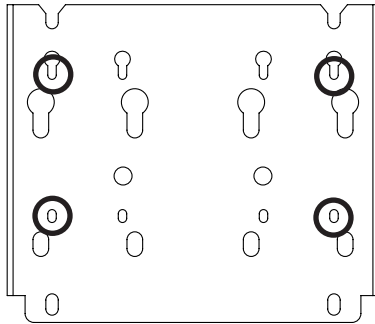

VESA 200 x 200

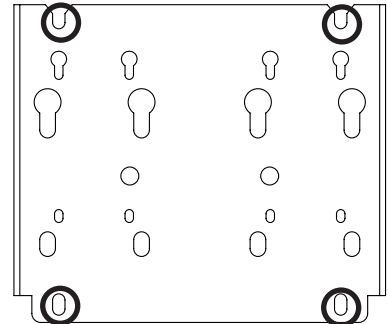

FOR VESA 100 MOUNTING PATTERN:

Thread two M4 x 12 mm screws (**BB**), leaving .25" exposed thread, into top holes on back of screen. Hook screen onto mounting plate, and attach using bottom two M4 x 12 mm screws as shown in figures 4.4 and 4.5. (page 8) Tighten all four screws.

Note: If screw (**BB**) is too small to engage threaded inserts, attach mounting plate to back of screen using four M5 x 10 mm screws (**AA**).

4 FOR VESA 200 mm x 200 mm MOUNTING PATTERN:
 Thread two M6 x 12 mm socket pin screws (**FF**) with 1/4" flat washers (**EE**) or M8 x 12 mm socket pin screws (**GG**), leaving .25" exposed thread, into top holes on back of screen as shown in figure 4.1. Hook screen onto mounting plate slots, and attach using two bottom M6 x 12 mm socket pin screws (**FF**) with 1/4" flat washers (**EE**) or M8 x 12 mm socket pin screws (**GG**) as shown in figures 4.2 and 4.3. Tighten all four screws.
NOTE: Only use 1/4" flat washers (**EE**) with M6 x 12 mm socket pin screws (**FF**).

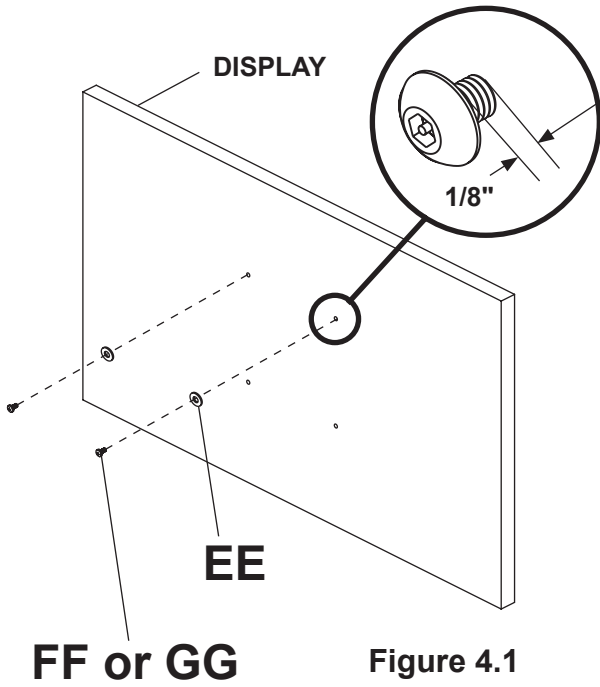

Figure 4.1

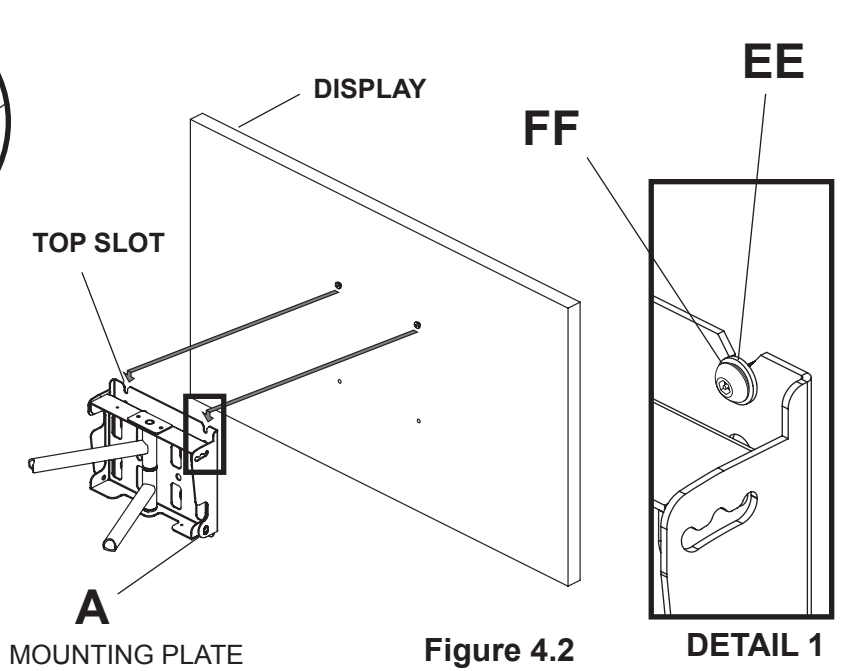
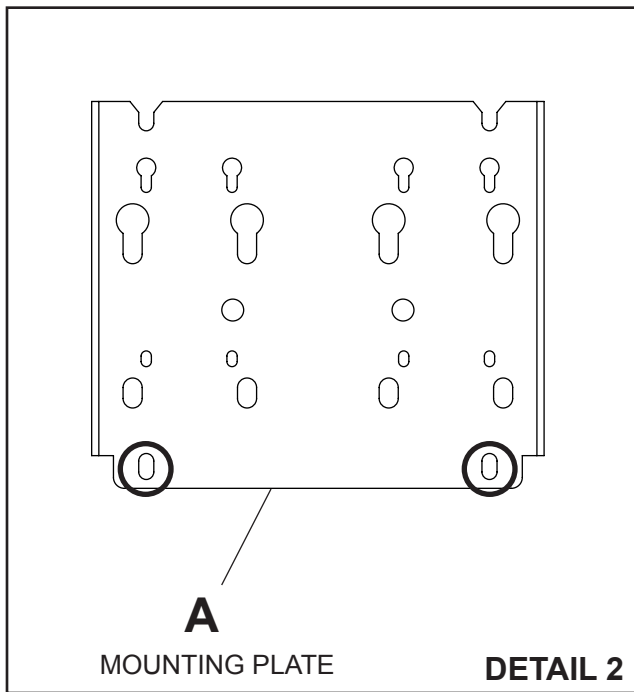

Figure 4.2



DETAIL 2

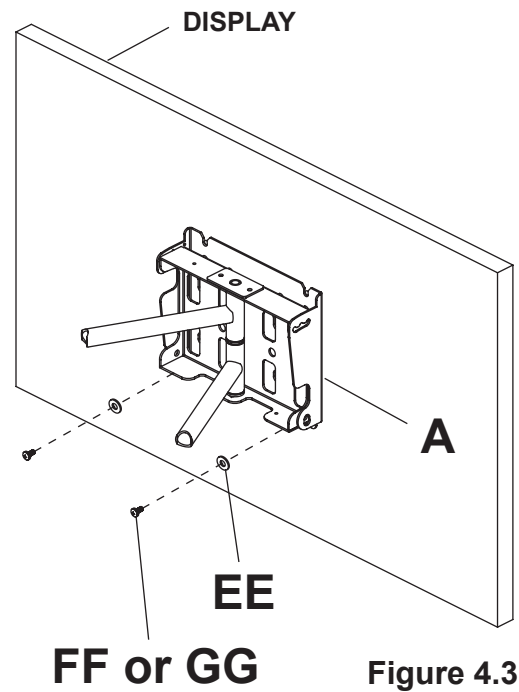

Figure 4.3

NOTE: Only use 1/4" flat washers (**EE**) with M6 x 12 mm socket pin screws (**FF**).

FOR VESA 200 MOUNTING PATTERN:

Thread two M4 x 12 mm screws (**BB**), leaving .25" exposed thread, into top holes on back of screen. Hook screen onto mounting plate, and attach using two bottom M4 x 12 mm screws as shown in figures 4.4 and 4.5. Tighten all four screws.

FOR SCREENS WITH VESA MOUNTING PATTERN IN A POCKET:

Thread two retaining spacers (**I**) onto two M4 x 20 mm screws (**CC**), leaving .25" exposed thread as shown in figure 4.6. Thread M4 x 20 mm screws with retaining spacers into top holes on back of screen. Hook screen onto mounting plate, and attach using bottom two M4 x 20 mm screws and retaining spacers as shown in figures 4.4 and 4.5. Tighten all four screws.

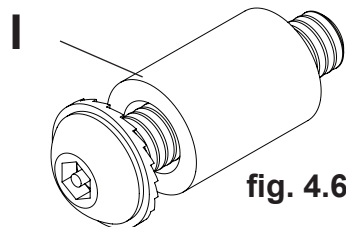
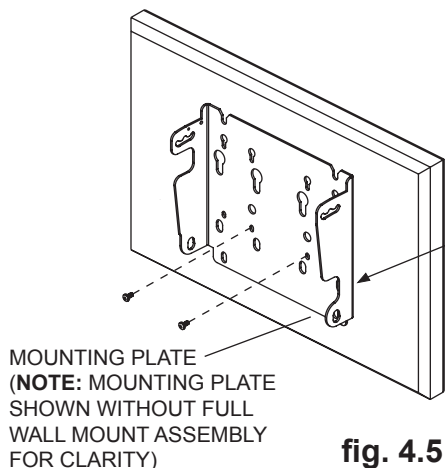
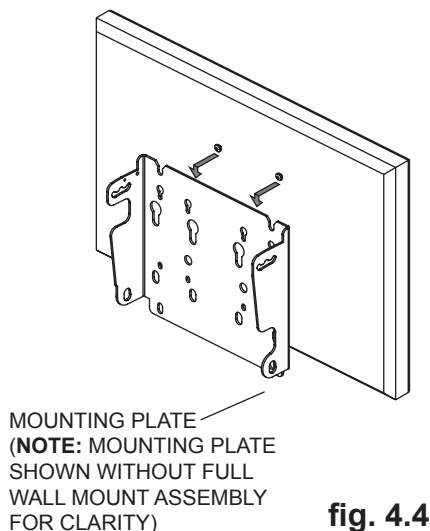

For screens with a hole pattern in a pocket, spacers (**L**) go between mounting plate and screen.

Note: Flat panel screen may appear slightly different than illustrated.

For screen compatibility please refer to the plasma interface list on our website www.peerlessmounts.com or call customer care for a screen specific adapter bracket (PLP models).

FOR INSTALLING TO PEERLESS PLP MODEL ADAPTER BRACKET (not UL listed)

Note: Refer to PLP model adapter bracket instruction sheet for attachment of adapter bracket to screen.

- 5** Thread two M10 x 15 mm screws (**H**), leaving .25" exposed thread, into top holes on back of screen. Hook screen onto mounting plate, and attach using two bottom M10 x 15 mm screws as shown in figures 5.1 and 5.2. Tighten screws using 6 mm allen wrench (not included).

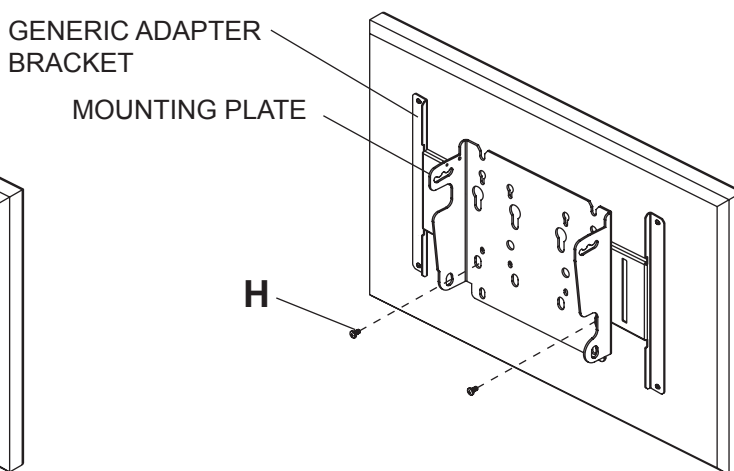
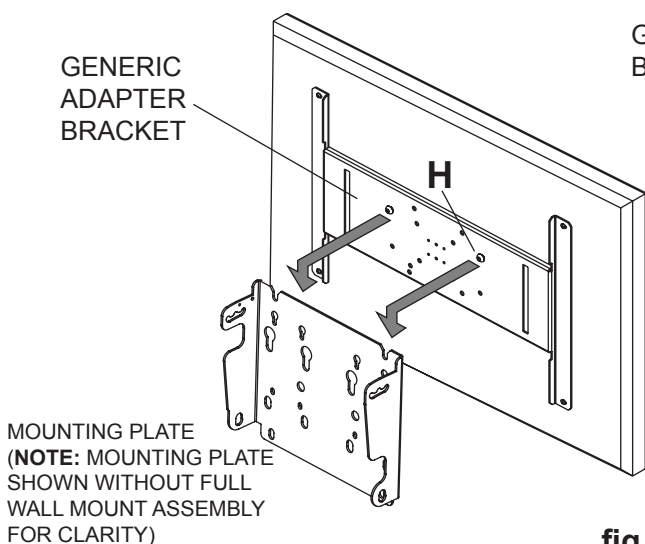

- 6** Slide one mesh sleeve (**F**) over each cable. Use cable ties (**G**) to tighten both ends of mesh sleeves to cables.

Note: Loop cable ties through cable mounts and tighten cable and mesh sleeve to cable mounts.

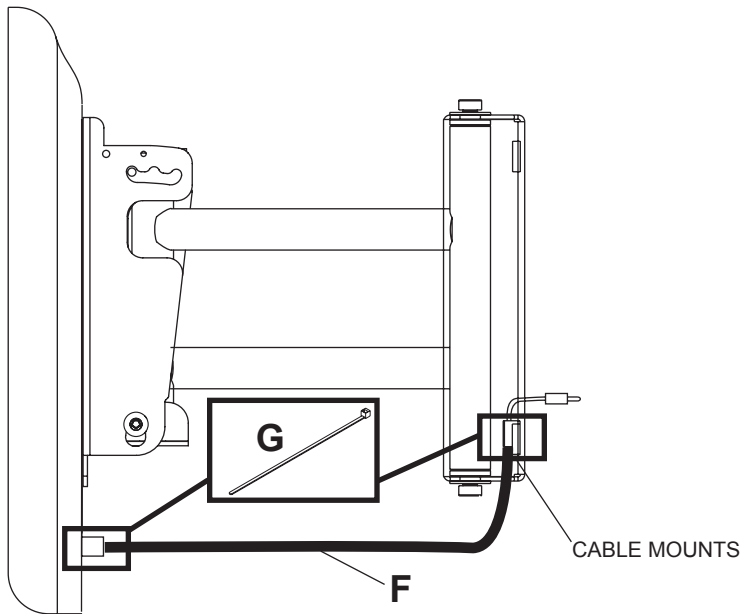

- 7** **Optional:** To lock mount in closed position, insert one M5 x 40 mm screw (**DD**) into tapped hole in either top or bottom of flat plate.

Note: Screen not shown for clarity.

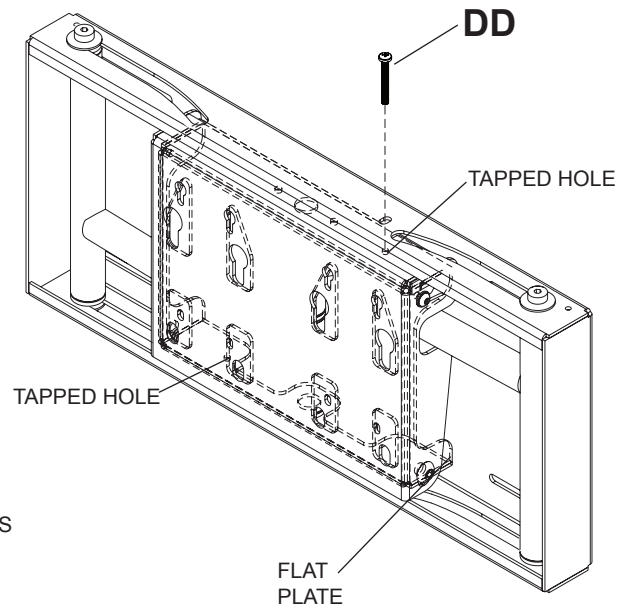

- 8** Screen can tilt 5° or 10° forward. **Note:** Screen must be securely attached to mounting plate with all fasteners before adjusting tilt.

To tilt screen 5° forward, lift and pull mounting plate forward until middle notch rests on M6 screw as shown in figure 8.1. Tighten M6 screw (both sides) and M10 screws (both sides).

To tilt screen 10° forward, lift and pull mounting plate forward until rear notch rests on M6 screw as shown in figure 8.2. Tighten M6 screw (both sides) and M10 screws (both sides).

Note: For security models, tighten M6 screw using security allen wrench (**J**). For all M10 screws, use 6 mm allen wrench (not included).

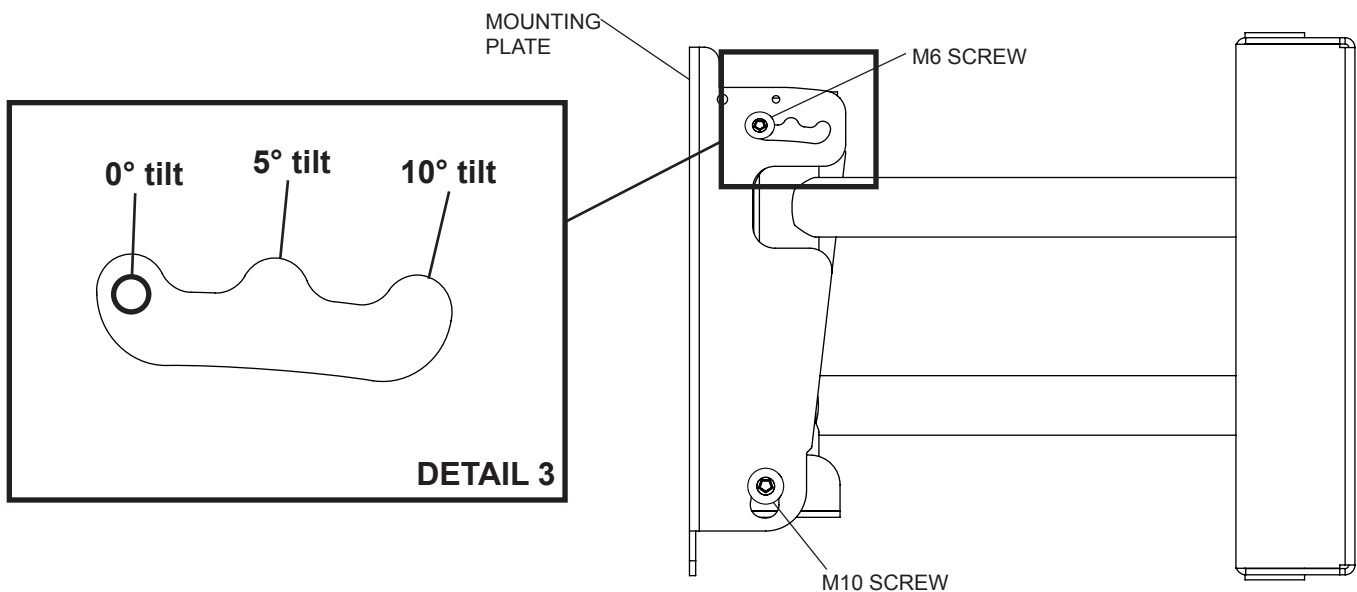

9 Roll can be adjusted 1° clockwise or counterclockwise.

To adjust roll, loosen screen fasteners slightly, leaving them snug. Level screen, then tighten screen fasteners.

NOTE: When adjusting roll, screws should be retightened as indicated in step 4.

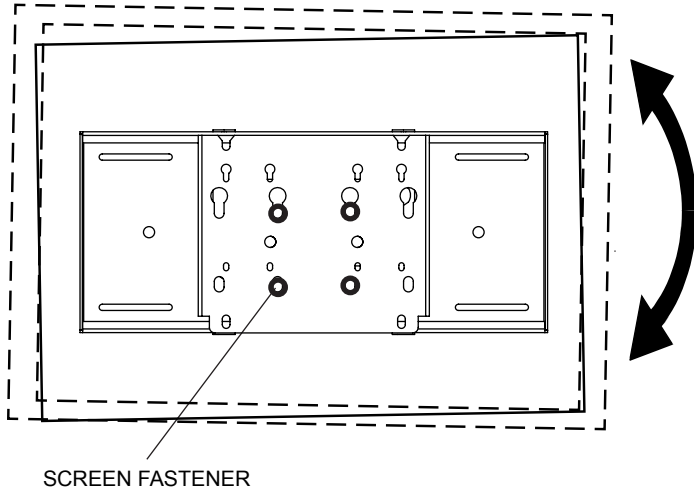

10 Optional: To lock one sliding arm of mount in place, slide locking tab (B) over top or bottom of sliding arm and attach to mount using one M5 x 10 mm screw (AA) and one spacer (C).

Note: Screen not shown for clarity.

