

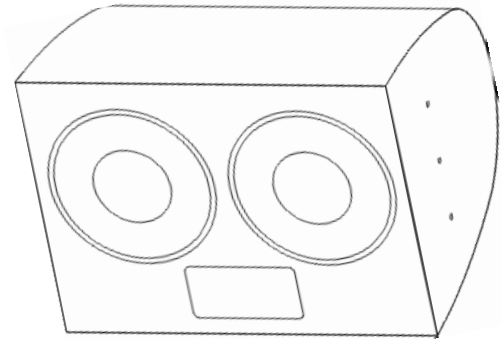

W2-125

WET SERIES II DUAL 15-INCH SUBWOOFER



Description

The W2-125 subwoofer is a high output, high sensitivity, vented low frequency system with solid low frequency response down to 30 Hz. It includes two 15" cast-frame, carbon-fiber, double-spider, Ferrofluid-cooled speakers mounted to a vented enclosure.

Engineered for use in permanent installations, the loudspeaker enclosure and faceplate are constructed of multilayer glass composite, providing extreme structural strength. A three-layer Weather-Stop™ grille provides weather-resistance to the internal components, while all exposed hardware is stainless steel or powder-coated aluminum extrusion. Six 1/2-13 mounting points are included.

The W2-125 is backed by a five-year product warranty plus a fifteen-year enclosure warranty.

Applications

- Theme and Amusement Parks
- Outdoor Entertainment Centers
- Cruise Ships
- Swimming Pools
- Music Pavilions
- Musical Fountains
- Water Parks

Features

All-Weather, Multilayer Glass Composite Enclosure

Stainless Steel Hardware

Integral Mounting Points

Dual-layer Powder Coated Weather-Resistant Stainless Steel Grille

Ferrofluid-Cooling

Available in Black or White Finishes

SYSTEM

Format: Dual 15-inch subwoofer

Operating Range: 30 Hz - 1 kHz

Frequency Response: 35 Hz - 160 kHz (±3 dB)

Dispersion (-6 dB): 360° H x 180° V

Maximum SPL @1m: 125 dB continuous / 132 dB peak

Crossover Frequency: N/A

Sensitivity in SPL: 99 dB (50 Hz - 160Hz, 1/3 octave)
(1W/1m, free space)

Max Power Handling: 400 W RMS
1000W Program

Impedance: Nominal 4Ω / Min. 3.7Ω at 130 Hz

TRANSDUCERS

Low Frequency: 2 x 15" cast-frame, carbon-fiber, double-spider (381 mm)

MECHANICAL

Enclosure: Hand-laminated fiberglass

Finish: Black or white gelcoat

Rigging Provisions: Six 1/2-13 rigging points

Input Connection: 16-2 SJOW (12 ft. / 4m)

Grille: Three-layer Weather-Stop™

Dimensions: 24.38" (619 mm) x 33.63" (854 mm)
H x W x D x 24.25" (616 mm)

Net Weight: 91 lbs / 41.3 kg

Recommended signal processing available at communitypro.com.

FREQUENCY RESPONSE

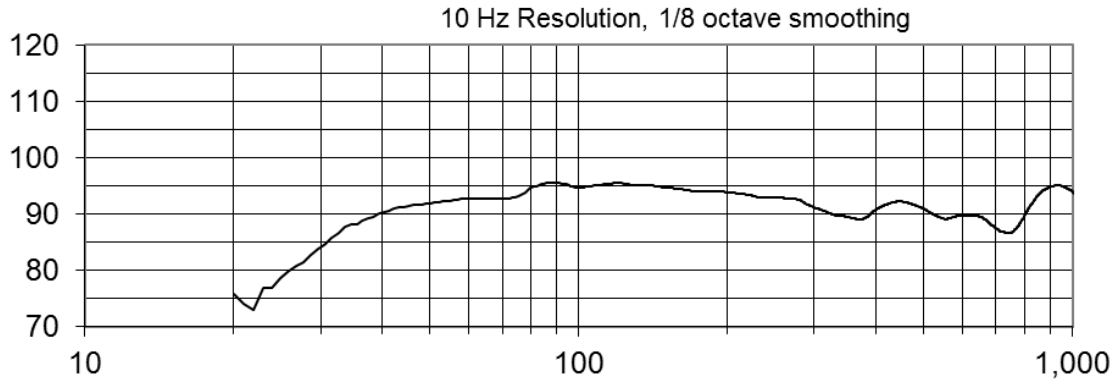

IMPEDANCE

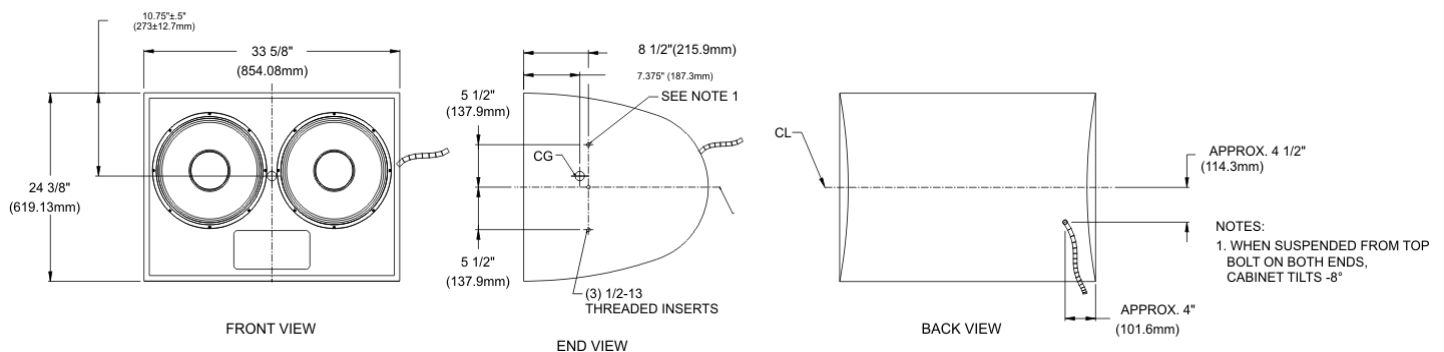
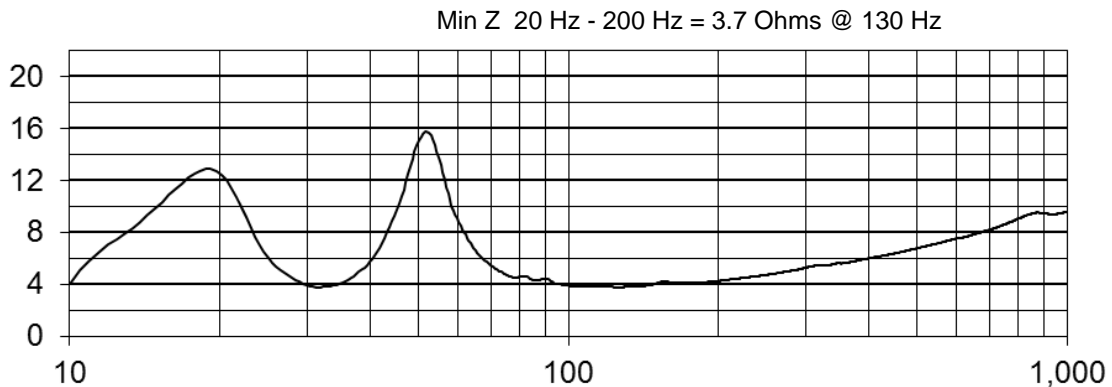

Architects' and Engineers' Specifications

The loudspeaker system shall be a vented bass reflex multilayer glass composite cabinet with two cast-frame, carbon-fiber, double-spider 15-inch Ferrofluid-cooled woofers. There shall be a 12' (4m) #16 gauge SJOW input connector. There shall be six 1/2-13 integral threaded mounting points connected to internal bracing. The system shall have an amplitude response of 35 Hz - 160 kHz (±3 dB), input capability of 40V RMS, 99 dB sensitivity at one meter and 2V input with 4 ohms nominal impedance. The nominal dispersion shall be omnidirectional throughout the operating range. The loudspeaker shall be 24.38 in. (619 mm) high x 33.63 in. (854 mm) wide x 24.25 in. (616mm) deep and weigh 91 lbs (41.3 kg).

Community strives to improve its products on a continual basis. Specifications are therefore subject to change without notice.

Community Professional Loudspeakers, 333 East Fifth Street, Chester, PA USA 19013-4511
 TEL: 610-876-3400 · FAX: 610-874-0190 · www.communitypro.com