

## General Description

Simple Division. You do the math. Any way you add it up, Rane makes the finest crossovers. There is no simpler or smarter way to triamp your system than with the SAC 23 Stereo Active Crossover.

The SAC 23 employs state-variable 4th-order Linkwitz-Riley filter alignments to minimize phase difficulties in the critical crossover region. Simply put, a Linkwitz-Riley crossover exhibits identical phase characteristics on its Low pass and High pass Outputs. This characteristic guarantees in-phase outputs at all frequencies. In-phase outputs are mandatory for proper acoustic summing of common signals from adjacent drivers in the crossover region. An added benefit of this topology is steep 24 dB per octave rolloff slopes. A slope of this magnitude guarantees drivers designed to produce a specific range of frequencies, and no more, will not be driven past their limits, thereby minimizing distortion and driver fatigue. For deeper information, see RaneNote 107, "Linkwitz-Riley Crossovers."

## Features

- Precise Channel Matching with Single Set of Controls
- 31-Position Frequency Selector
- High, Mid, Low and Mono Subwoofer Output Level Controls
- +4 dBu and Overload Indicators
- 24 dB/Octave Linkwitz-Riley Filters
- Separate Mono Subwoofer Output
- Balanced XLR Connectors
- Internal AC Power Supply Meets CE Requirements

The SAC 23 utilizes 31-position precision DC control voltage potentiometers to select the Low/Mid and Mid/High Frequency points. This crossover circuit design assures consistent accuracy from channel-to-channel and unit-to-unit. This is a distinct advantage over continuously variable designs using ganged potentiometers which can yield large variations in channel-to-channel matching.

The Mono Subwoofer Output provides a separate mono sum of the Left and Right Low Outputs. A 100 Hz low pass filter may be activated for this Output. The Subwoofer Output may be used along with the Left and Right Low Outputs.

The Input Level allows decreasing the overall sensitivity of the entire sound system, including the mono subwoofer if one is used. The Low Level, Mid Level, High Level and Mono Subwoofer Output Level controls allow compensation for sensitivity variations in amplifiers and drivers.

The SAC 23 features balanced XLR connectors that when properly connected, can drive long lines without fear of hum or noise.



**SAC 23 Crossover Features and Specifications**

Parameter	Specification	Limit	Units	Conditions/Comments
Crossover:				
.....Alignment	Linkwitz-Riley			Proprietary 4th-order state variable
.....Slope	24 dB per Octave			
.....Range Low/Mid	80 Hz-1 kHz			
.....Range Mid/High	350 Hz-7 kHz			
.....Control	Stereo			31-detent continuously variable
.....Tracking	2%	max		Channel-to-channel tracking error
.....Accuracy	10%	max		Frequency selector error
Inputs: Type	Active Balanced			
.....Connectors	XLR			Pin 2 "hot" per AES standards
.....Impedance	20k	1%	ohms	
.....Maximum Level	+20	1	dBu	
.....Gain Range	Off to +6	±5	dB	
Outputs: Type	Active Balanced			
.....Connectors	XLR			Pin 2 "hot" per AES standards
.....Impedance	100	1%	ohms	Each leg
.....Maximum Level	+20		dBu	2k ohms load
.....Gain Range	Off to +0	1	dB	
Mono Sub:				
.....Filter	100 Hz Low Pass	±3%		3rd-order Butterworth
.....Gain Trim	Off to +0		dB	
RFI Filters	Yes			
Infrasonic Filters	15 Hz, 18 dB/Octave	3%		Butterworth, Fc accuracy
Frequency Response	15 Hz-40 kHz	+0/-3	dB	R load > 2 kHz
THD+Noise	0.20%	max	%	+4 dBu, 20 Hz to 20 kHz
Signal-to-Noise Ratio	84		dB	Max. gain re +4 dBu, 20 kHz BW
Indicators:				
.....+4 dBu	+4 dBu	±1	dB	Green LED
.....OverLoad	3 dB Before Clip	±1	dB	Red LED
.....Power	Unit On			Yellow LED
Unit: Agency Listing				
.....120 VAC model	UL cUL (Canada)			UL 6500 (file E193164) C22.2 (file E104174)
.....230 VAC model	CE-EMC EN55013, EN55020 CE-Safety EN 60065			EMC directive 89/336/EEC LV Directive 73/23/EEC
Unit: Construction	All Steel			
.....Size	1.75"H x 19"W x 5.3"D (1U)			(4.4 cm x 48.3 cm x 13.5 cm)
.....Weight	5 lb			(2.3 kg)
Shipping: Size	4.25" x 20.3" x 13.75"			(11 cm x 52 cm x 35 cm)
.....Weight	8 lb			(3.6 kg)
Note: 0 dBu = 0.775 Vrms				

#### SAC 23 Block Diagram

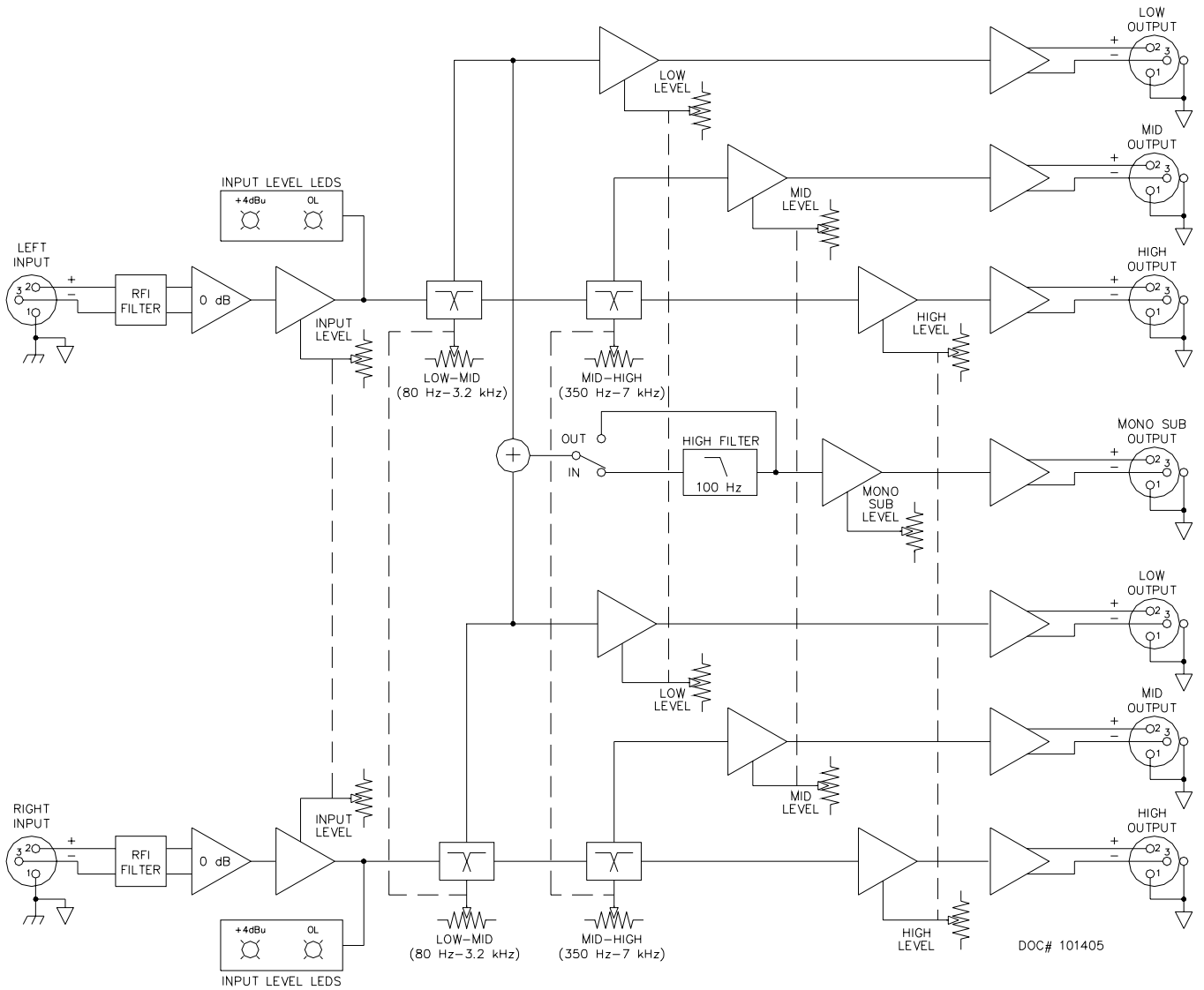

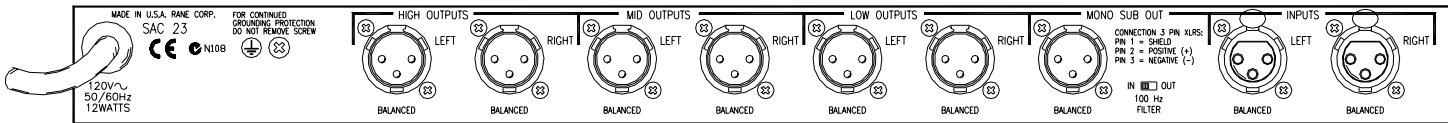
**SAC 23 Rear Panel****Architectural Specifications**

The active crossover shall be of stereo 3-way design with an additional mono subwoofer output. The crossover shall contain 4th-order Linkwitz-Riley filters. The crossover frequencies shall range from 80 to 1000 Hz and 330 to 7000 Hz, controlled by variable controls with 31 detents to allow mechanical reference of crossover setting. The active crossover shall afford an input level range of Off to +6 dB. The output level controls shall afford a level range of from Off to +0 dB. Both channels shall be operated by a single set of controls.

LEDs shall indicate both +4 dBu and overload conditions. Inputs and outputs shall be of active balanced design terminated with XLR connectors. RFI filters shall be provided.

The unit shall be capable of operation by means of its own built-in power supply connected to 120 VAC (240 VAC where applicable) and meet CE requirements. The unit shall be entirely constructed from cold-rolled steel.

*The unit shall be a Rane Corporation SAC 23 Active Crossover.*