



General Description

The AC 24 stereo 4-way Crossover combines conventional analog controls and DSP signal processing. The AC 24 is ideal for those who want the features and accuracy of DSP, but prefer not to use a PC for control. One knob = one function — no confusion. This approach allows a full-featured, high performance product that doesn't break the bank. The AC 24 is a truly affordable crossover that features the very best technology, with exactly the right features.

The AC 24 combines Rane's exclusive phase compensated, 4-way *Linkwitz-Riley-Plus* crossover filters with independent time delay and limiting for each output. Once settings are made, an included security cover guards all controls. With these tools, it is possible to realize a well-protected sound system that exhibits unsurpassed clarity and accuracy.

See the RaneNote *Linkwitz-Riley Crossovers* at the Rane website for background information.

Special AC 24 Features

- Exclusive Automatic Phase Compensation
- Independent Alignment Delays
- Independent Limiters
- CD Horn EQ on the Hi-Mid and High Outputs
- Stereo Link Switch
- Summed Output Use for Band-Split Limiting and Tone Controls
- Internal Universal Power Supply
- Included Security Cover

Why *Linkwitz-Riley-Plus*?

- Absolutely flat amplitude response through out the passband.
- Steep 24 dB per octave roll-off rate after the crossover point.
- All outputs are everywhere in phase.
- Excellent transient response.

Applications:

- 4-Way or 3-Way Operation
- Independent, Dual-Mono Crossover
- Linked Control, Stereo Crossover
- Split-Band Limiter
- 4-band, 4th-Order, 24 dB per Octave Tone Controls

Features and Specifications

Parameter	Specification	Limit	Units	Conditions/Comments
Inputs: Type	Active Balanced			Channel A, Channel B
.....Connectors	XLR			Pin 2 hot per AES standards
.....Maximum Input	+22	1	dBu	1 kHz
.....Common Mode Rejection	40	min.	dB	60 Hz
.....Impedance	7.33k	1	Ω	Each leg to ground @ 1 kHz
24-bit Converters: Sample Rate	48		kHz	
.....Dynamic Range	106	typ.	dB	A-weighted (input to output); unity
DSP Block				
.....Low-Cut Filter	15		Hz	12 dB per octave
.....Input Level: Range	80		dB	256 steps; audio taper
.....Maximum Gain	6		dB	
.....Input Overload Indicator	4 dB before clip		dB	After Input Level control
.....4-Way Crossover				
.....Low / Mid:	31.5 to 315		Hz	64 steps
.....Mid / Hi-Mid	160 to 1.6k		Hz	64 steps
.....Hi-Mid / High	1.25 to 12.5		kHz	64 steps
.....Phase Compensation	Automatic			Crossover-Filter
.....Mono Low Out switch	Yes			
.....4-Way / 3-Way switch	Yes			
.....Delay	Each Output			240 steps; 41.67 μ s resolution
.....Range	0 to 10		ms	(10 ms = 135 inches = 3.43 meters)
.....Limiter	Each Output			Independent Threshold Controls
.....Linking	High, Hi-Mid and Mid			Link Switch for Low
.....Range	0 to -64		dBFS	(128 steps = .5 dB per step)
.....CD Horn EQ	Independent Hi-Mid and High			Separate Engage switches
.....Range	2 to 8		kHz	32 steps
.....Filters	6 dB		oct.	
.....Band Muting Switches	Yes			Each band
.....Band Level Control	Yes			Each band
.....Range	80		dB	256 steps
.....Maximum Gain	+6		dB	Audio taper
.....Channel Link Switch	Yes			Channel-1 Master / Channel-2 Slave
Outputs:	Active Balanced			Low, Mid, Hi-Mid, High, Sum
.....Connectors	XLR			Pin 2 hot per AES standards
.....Impedance	100	1%	Ω	Each leg to ground
.....Maximum Output	+22	1	dBu	600 Ω or greater
.....Invert Switches	Yes			Low, Mid, Hi-Mid, High only
EMI Filters	Yes			Inputs and Outputs
Frequency Response	15 Hz to 20 kHz	+0/-3	dB	
THD+Noise	.005	typ.	%	+4 dBu, 20-20 kHz
Power Supply Requirement				100 to 240 VAC, 50/60 Hz, 20 W
Unit: Agency Listing				UL/cUL/CE
Unit: Construction	All Steel			
.....Size	3.5" H x 19" W x 5.25" D (2U)			(8.9 cm x 48.3 cm x 13.3 cm)
.....Weight	7.3 lb			(3.3 kg)
Shipping: Size	4.5" x 20.3" x 13.75"			(11.5 cm x 52 cm x 35 cm)
.....Weight	12 lb			(5.5 kg)

Note: 0 dBu=0.775 Vrms

Block Diagram (typical for both channels)

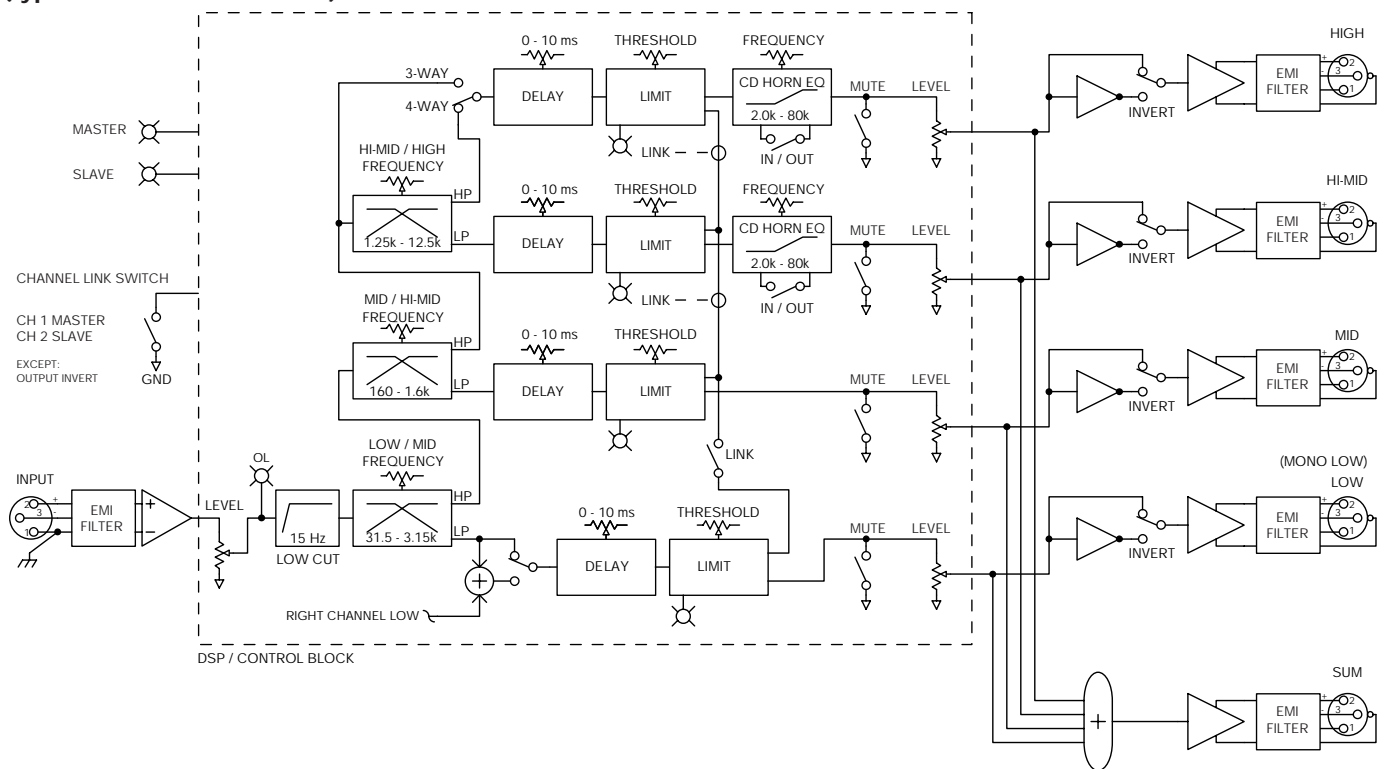

Rear Panel

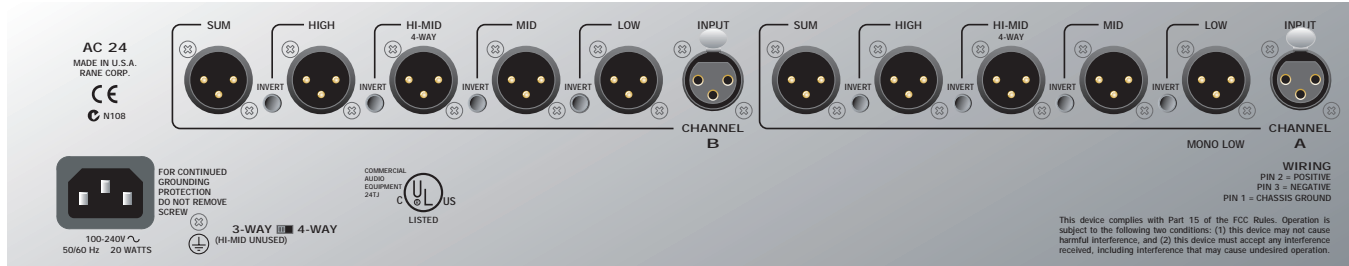

Architectural Specifications

The active crossover shall contain digitally-controlled 4th-order Linkwitz-Riley-Plus phase-compensated filters. All control shall be provided from standard controls and switches on the front panel. The crossover shall provide a switch to allow 3-way or 4-way operation on the rear of the unit.

Provisions shall exist to correct for driver misalignment by adding 0 to 10 ms of time delay to the low, mid, hi-mid and high frequency outputs.

Signal inputs and outputs shall be active balanced design terminated with XLR connectors. EMI filters shall be built-in.

Signal limiters shall be built in, with individual threshold controls for each output. The mid, mid-high and high output limiters shall be linked, and a switch shall be provided to link the low output limiter.

The crossover shall supply two independent channels. A switch shall be provided to link the two channels.

The unit shall provide summed outputs that recombine the crossover outputs for each channel. The unit shall provide a switch to sum the low outputs for mono subwoofer operation.

The active crossover shall allow an input level range of Off to +6 dB. The output level controls shall allow a level range of from Off to +6 dB. Mute and invert switches shall be provided on the low, mid, hi-mid and high frequency outputs.

The unit shall include a 19" by 3.5" security cover.

The unit shall meet CE and UL agency safety requirements and be powered from an internal universal power supply (100 to 240 VAC) via a rear panel IEC connector. The unit shall be constructed entirely from cold-rolled steel. The unit shall be supplied with ears for mounting into a standard 2U EIA rack.

The unit shall be a Rane Corporation AC 24 Active Crossover.

References

1. S.H. Linkwitz, "Active Crossover Networks for Noncoincident Drivers," *J. Audio Eng. Soc.*, vol. 24, pp. 2-8 (Jan/Feb 1976).
2. D. Bohn, "A Fourth-Order State-Variable Filter for Linkwitz-Riley Active Crossover Designs," presented at the 74th Convention of the Audio Engineering Society, New York, Oct. 9-12, 1983, preprint no. 2011.
3. D. Bohn, "Linkwitz-Riley Crossovers," *RaneNote*, (1983).
4. D. Bohn, "Why Not Wye?" *RaneNote*, (1984).
5. D. Bohn, "Overload Characteristics of State-Variable Crossovers," *RaneNote*, (1985).
6. D. Bohn, "Linkwitz-Riley Active Crossovers Up To 8th-Order: An Overview," *RaneNote*, (1989).