

DR-PCB-HxxM

HDMI Digital Ribbon Cables

FSR

Video Products Group

DR-PCB-HxxM



DESCRIPTION

FSR's DR-PCB-H DIGITAL RIBBON CABLES utilize a proprietary technology to allow high speed, high definition HDMI signal transmission over distances of up to 328 ft. Active circuitry embedded in the connector shells provide all the active signal buffering needed, and eliminate additional bulky electronics.

The cables hybrid polymer/copper structure delivers a speed of 10.2 Gb/sec video bandwidth and can easily handle 1080p Full HD, 3D, Deep color, HDMI-CEC, HDCP and most newer hi-res formats. The small ribbon shaped jacket is 5mm x 2.5mm and is currently available in six lengths, ranging from 33 to 328 feet. The cables are UL listed, plenum rated and provide optical performance at the price and simplicity of copper.

With optical-to-electronic conversion contained inside the connectors, this cable uses the same standard HDMI ports as copper cables. The cables require no bulky external power connectors or extenders, instead drawing power entirely from the HDMI port without exceeding HDMI maximum power output standards.

Optical communications provide immunity to electromagnetic and radio-frequency interference and offer high reliability in challenging environments such as outdoor displays, convention centers, stadiums, airports shopping malls, hospitals, factories, and other potentially high noise environments.

The optical component within the ribbon cable bundle is plastic fiber rather than glass and can be installed in areas that require tight cable bends that were prohibitive with a conventional fiber bundle. At the same time, they are cost competitive with copper-based alternatives.

All cables carry a 3 year warranty excluding damage from abusive wear and tear.

FEATURES

- Overcomes distance limitations of conventional HDMI cables
- Competitive in cost to older cable types
- Signal integrity is uncompromised
- Multi format compatibility
- No external power or special tooling required
- Cable and connectors easily fit within a 1" conduit
- Plenum Rated - Type CMP, CMR
- UL Listed
- Supports DDC for HDCP and EDID
- Supports PCM, Dolby, DTS-HD and True HD audio

ORDERING INFORMATION

DR-PCB-H10M	33'
DR-PCB-H15M	50'
DR-PCB-H23M	75'
DR-PCB-H30M	100'
DR-PCB-H50M	165'
DR-PCB-H70M	230'
DR-PCB-H100M	328'
DR-SOCK	DR CABLE PULLING SOCK ACCESSORY

HDMI® (HDCP)



Specifications are subject to change without notice.

FSR Inc.

244 Bergen Boulevard, Woodland Park, NJ 07424

Phone: 973.785.4347 · Fax: 973.785.4207

Order Desk: 1-800-332-FSR1

Web: www.fsrinc.com · E-mail: sales@fsrinc.com

LIT1450B

SPECIFICATIONS

Performance Characteristics	
Video Connectors	Male HDMI
Maximum Length	328' (100 meters)
Dimensions	0.2" x 0.11" (5 mm x 2.8 mm)
UL Listing	CMP-OF
Compliance	RoHS, NFPA 262
HDMI Cable Type	High-Speed HDMI
Total Power Consumption	0.25 Watts
Endurance at Bend Radius	Over 10k cycles at 2" (50 mm) Radius
Minimum Bend Radius	0.2" (5 mm)
Maximum Tensile Load	100 N (10 kg)
Environmental Performance	
Operating Temperature Range	32 °F to 122 °F (0 °– 50°C)
Maximum Operating Humidity	85%
Storage Temperature Range	-22 ° to 122 ° F (-30° to +50°C)
Product Specifications	
<ul style="list-style-type: none"> • 1080p Full HD • 3D • Deep Color • 10.2 Gb/sec video bandwidth 	<ul style="list-style-type: none"> • Supports DDC for HDCP and EDID • HDMI-CEC • No ARC (Audio Return Channel) • Supports PCM, Dolby, DTS-HD and True HD audio

APPLICATIONS

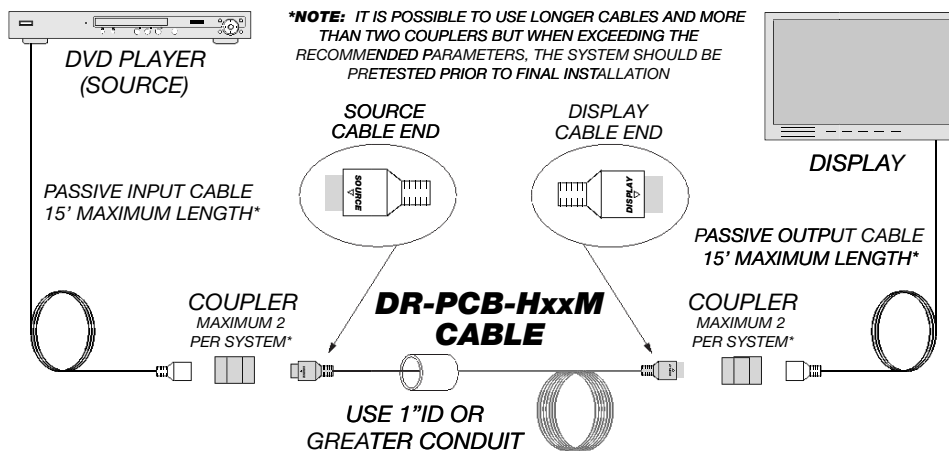

IMPORTANT:
Do not use any pulling method that will result in a localized twisting of the cable or damage will result and the warranty will be voided.

DIMENSIONS

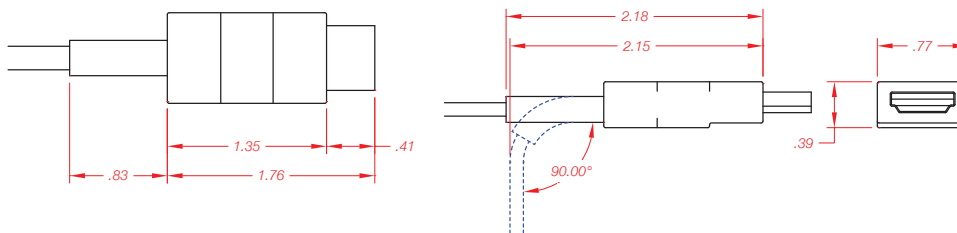

FSR Inc.

244 Bergen Boulevard
Woodland Park
NJ 07424
Phone: 973.785.4347
Fax: 973.785.4207
Order Desk: 1-800-332-FSR1
Web: www.fsrinc.com
E-mail: sales@fsrinc.com