

Description

The LRS 4 provides a simple interface to end users requiring four predetermined volume levels (may include mute) when used in conjunction with devices equipped with voltage-controlled level inputs. Rane's CP 64, CP 52 or VIP-equipped devices such as the Drag Net family: RPM 88, RPM 44 or RPM 22 are all compatible with the LRS 4.

The LRS 4 accepts a two-wire DC voltage input (VREF and ground) and outputs a single voltage (VC) that is varied depending on the selected LRS 4 button. Thus, four volume levels can be setup during installation. Any button may be set to any gain between unity and mute. Typically, 4 is set for the highest gain with 3, 2, 1 graduating down to mute, if available.

The LRS 4 fits in a standard US electrical box and can be paired with Decora™ plates for improved architectural beauty. The LRS 4 contains four radio buttons: engaging one button (*in, changing to green*) causes any of the other three to disengage (*out, changing to black*).

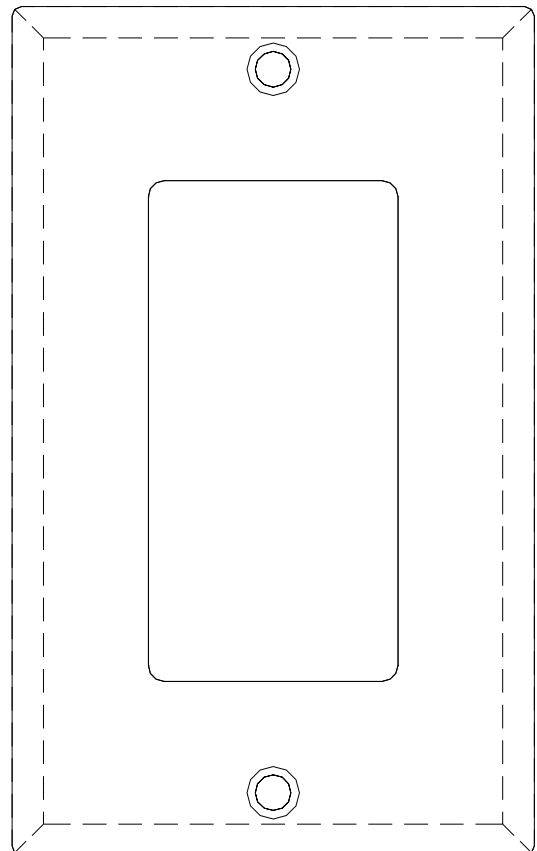

Decora™ plate not included.
Decora is a trademark of Leviton.

Remote Mounting and Wiring

The LRS 4 remote assembly mounts in a standard U.S. electrical box with a minimum depth of 2.5". Turn the power to the unit *off* until all connections are made. It is important to ensure that the Remote Ports are not subjected to sustained voltages outside the range of 0 to 5 volts DC or high levels of static. The device inputs are protected, however you can save a lot of time by taking this precaution. It is a good idea to install the wiring, connect it to the Remote and then make the final connections at the unit.

When wiring to Euroblocks, a minimum wire gauge of 22 is preferred for reliability. If the ground or shield wire is left shorter, it acts as a strain relief for the other wires. Cable with a flexible jacket is easier to use and less likely to damage the connections. Be sure to note the wire color of each input in order to facilitate correct wiring to the unit. Make sure wires are free of nicks and that the cable jacket is stripped back sufficiently to allow it to lie in the electrical box with the remote assembly inserted. Connect each wire to the 5-pin connector by fully inserting it in the correct socket and tightening the screw.

Use the flat head #6 screws supplied with the kit to mount the remote assembly and silkscreened front panel to the electrical box. Install the Decora plate of your choice (not included).

Wire Types

Variations in wire type do not greatly affect the performance of the remote controls. However, 22-gauge stranded wire with a flexible jacket is recommended. You may use 3-conductor unshielded remote control signal cable for shorter runs (less than 200 ft.) or 2-conductor (1 pair) shielded remote control signal cable (use the shield as the GND return) for longer runs (200 to 1000 ft.). The type of wire required is influenced by your installation and local electrical codes.

Rane Corporation does *not* provide or source cable. Please contact your local retail or wholesale outlet, *not* the factory. The following is a short list of suitable cable types:

CONSOLIDATED ELECTRONIC WIRE AND CABLE

Plenum cable:

Unshielded remote control signal cable CAT. #9896

Shielded remote control signal cable CAT. #9877 or #9852

WEICO WIRE & CABLE INC.

Communication and control cable:

Multiconductor, unshielded CAT. #7606

ALPHA

Communication and control cable:

Multiconductor, unshielded CAT. #1175C

BELDEN

Unshielded remote control signal cable CAT. #88741

Shielded remote control signal cable CAT. #88723

Block Diagram / Schematic

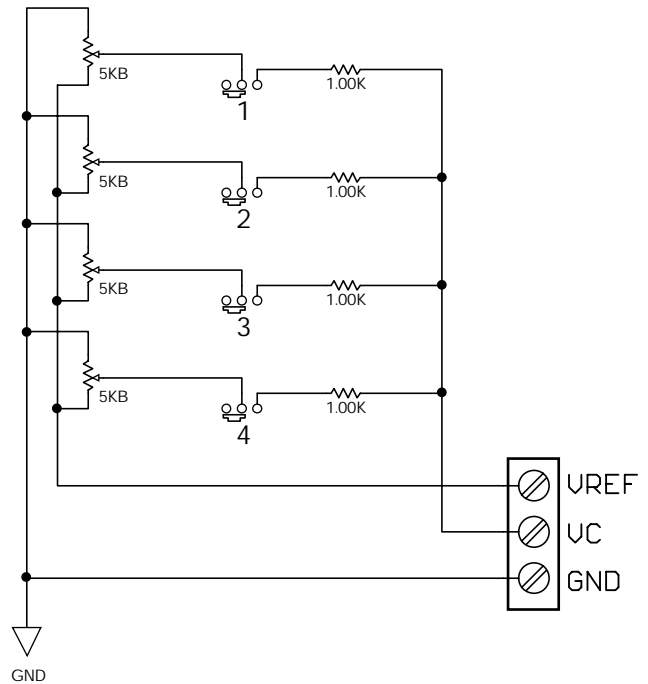

LRS 4	CP 64	CP 52	DA 26	MP 44	RPM *
VREF	VR1or2	VR	REF	VR	REF
VC	V1or2	VC	VC	VC	1-8
GND	↗	↗	↗	↗	GND

Use this chart to connect the LRS 4 to various Rane units.

