

Nikon

DIGITAL CAMERA

1 AW1

User's Manual



En

Table of Contents

Getting the Most from Your Camera	3
Product Documentation	6
For Your Safety.....	7
Shock-, Water-, and Dust-Proofing	10
Shock-Proofing	10
Water- and Dust-Proofing.....	10
<i>Important: Waterproof Lenses</i>	11
Precautions: Shock-Proofing.....	11
Precautions: Water- and Dust-Proofing	11
Operating Environment.....	13
<i>Important: Location Data (GPS/GLONASS)</i>	14
Notices.....	15
Introduction	20
Package Contents.....	20
Parts of the Camera.....	21
First Steps.....	31
Taking and Viewing Photographs	40
Point-and-Shoot Photography (Auto Mode)	40
Viewing Photographs.....	44
Deleting Pictures	45
Live Image Control.....	47
Choosing a Creative Mode.....	49
Choosing a Mode That Matches the Subject or Situation.....	50
Underwater (🏊 (🌊, 📷)).....	50
Night landscape (🌃)	50
Night portrait (👤).....	51
Backlighting (📷).....	51
Easy panorama (📷).....	51
Soft (📷).....	51
Miniature effect (📷).....	51
Selective color (🖌️).....	51

Taking Photos in P, S, A, and M Modes.....	52
Backlighting.....	57
Easy Panorama.....	58
Underwater Photography	61
<hr/>	
<i>Important: Precautions</i>	61
Before Using the Camera Underwater	62
The Final Check	64
Taking Pictures Underwater	65
Tips and Tricks for Underwater Photography	67
Auto Distortion Control.....	67
The Built-in Flash.....	67
The Depth Gauge	68
After Using the Camera Underwater	71
The O-Ring	73
Recording and Viewing Movies	77
<hr/>	
Recording HD Movies	78
Taking Photographs During HD Movie Recording.....	80
Viewing Movies	81
Deleting Movies	82
Recording Slow-Motion Movies	83
More on Photography	87
<hr/>	
Continuous Mode	87
Self-Timer Modes	89
The Built-in Flash	91
The  (Action) Button	95
Shooting: Choosing a Shooting Mode.....	95
Playback: Scrolling Through Pictures	96
Menus: Outdoor Display	97

Menu Options	98
Playback Menu Options	98
Shooting Menu Options	99
Movie Menu Options	100
Image Processing Menu Options.....	100
Setup Menu Options	100
Connecting to a Computer	102
Installing the Supplied Software	102
System Requirements.....	103
Viewing and Editing Pictures on a Computer	105
Transferring Pictures	105
Viewing Pictures	107
Technical Notes	108
Optional Accessories	108
Non-Waterproof 1 NIKKOR Lenses.....	110
Approved Memory Cards	113
Storage and Cleaning	114
Underwater Use	114
Storage.....	114
Cleaning.....	114
Caring for the Camera and Battery: Cautions	115
Troubleshooting	119
Battery/Display.....	119
Shooting (All Modes)	119
Movies	120
Playback.....	120
Miscellaneous	120
Error Messages	121
Specifications	123
Nikon 1 AW1 Digital Camera.....	123
Battery Life.....	135
Index	136

Getting the Most from Your Camera

Take photos with the shutter-release button.

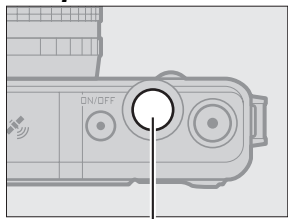

Shutter-release button

Photos can be taken in any mode by pressing the shutter-release button. See page 27 for more information.

Shoot movies with the movie-record button.

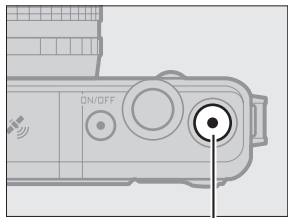

Movie-record button

Movies can be recorded by pressing the movie-record button in auto (📖 40), creative (📖 49), and advanced movie (📖 77) modes.

Shoot **underwater**.

Attach a special-purpose waterproof lens to take pictures at depths of up to 15 m (49 ft) for as long as 60 minutes at a time. See page 61 for more information. The camera offers the following features that may come in handy during underwater photography:

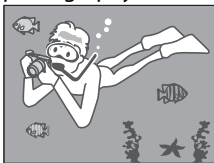

- Compensate for the blue cast in pictures taken under water (📖 65).
- Distortion control for underwater photographs and movies (📖 67).
- A built-in flash that can be used for additional lighting under water (📖 67).

Access altitude, depth, heading, virtual horizon, location data (GPS/GLONASS), and log options.

When shooting in locations with a clear view of the sky, you can:

- Access a variety of information, including a virtual horizon and your heading and altitude or depth (📖 25).
- Record location data (📖 101).
- Log your location or depth (📖 101).

Thank you for your purchase of a Nikon digital camera. For a complete guide to using your digital camera, see the *Reference Manual* (📖 6). To get the most from your camera, please be sure to read this *User's Manual* thoroughly and keep it where it will be read by all who use the product.

Camera Settings

The explanations in this manual assume that default settings are used.

Symbols and Conventions

To make it easier to find the information you need, the following symbols and conventions are used:



This icon marks cautions; information that should be read before use to prevent damage to the camera.



This icon marks notes; information that should be read before using the camera.



This icon marks references to other pages in this manual.

The lens generally used in this manual for illustrative purposes is a 1 NIKKOR AW 11–27.5mm f/3.5–5.6.

For Your Safety

Before using the camera for the first time, read the safety instructions in “For Your Safety” (📖 7–9), on pages 10–19, and in “Caring for the Camera and Battery: Cautions” (📖 115).

Product Documentation

The following documentation is supplied with the camera.

User's Manual (this manual)—Describes how to take and view pictures.

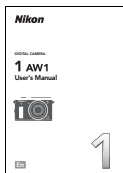

Reference Manual (on CD)—A complete guide to using your digital camera, included as a pdf file on the supplied Reference Manual CD-ROM.



The *Reference Manual* can be viewed using Adobe Reader or Adobe Acrobat Reader 5.0 or later, available for free download from the Adobe website.

- 1 Start the computer and insert the reference manual CD.
- 2 Double-click the CD (**Nikon 1 AW1**) icon in Computer or My Computer (Windows) or on the desktop (Mac OS).
- 3 Double-click the **INDEX.pdf** icon to display a language selection screen and click a language to display the *Reference Manual*.

For Your Safety

To prevent damage to your Nikon product or injury to yourself or to others, read the following safety precautions in their entirety before using this equipment. Keep these safety instructions where all those who use the product will read them.

The consequences that could result from failure to observe the precautions listed in this section are indicated by the following symbol:



This icon marks warnings. To prevent possible injury, read all warnings before using this Nikon product.

■ WARNINGS

- ⚠ **Keep the sun out of the frame.** Keep the sun well out of the frame when shooting backlit subjects. Sunlight focused into the camera when the sun is in or close to the frame could cause a fire.
- ⚠ **Observe caution in the presence of water or rain or when using the camera with wet hands.** The camera can be used underwater and safely handled with wet hands only when the special-purpose waterproof lens is attached and the battery-chamber/memory card slot and connector covers are closed. Do not immerse in or expose to water or handle with wet hands unless these conditions are met. Failure to observe these precautions could result in damage to the product, fire, or electric shock.
- ⚠ **Turn off immediately in the event of malfunction.** Should you notice smoke or an unusual smell coming from the equipment or AC adapter (available separately), unplug the AC adapter and remove the battery immediately, taking care to avoid burns. Continued operation could result in injury. After removing the battery, take the equipment to a Nikon-authorized service center for inspection.
- ⚠ **Do not disassemble.** Touching the product's internal parts could result in injury. In the event of malfunction, the product should be repaired only by a qualified technician. Should the product break open as the result of a fall or other accident, remove the battery and/or AC adapter and then take the product to a Nikon-authorized service center for inspection.
- ⚠ **Do not use in the presence of flammable gas.** Do not use electronic equipment in the presence of flammable gas, as this could result in explosion or fire.

- ⚠ **Keep out of reach of children.** Failure to observe this precaution could result in injury. In addition, note that small parts constitute a choking hazard. Should a child swallow any part of this equipment, consult a physician immediately.
- ⚠ **Before using the camera underwater, remove straps intended exclusively for use on land.** The strap could become wrapped around your throat, causing suffocation or drowning.
- ⚠ **Do not place the strap around the neck of an infant or child.** Placing the camera strap around the neck of an infant or child could result in strangulation.
- ⚠ **Follow the instructions of airline and hospital personnel.** This camera transmits radio frequencies that could interfere with medical equipment or aircraft navigation. Disable the location data and all track log functions and disconnect any wireless devices from the camera before boarding an aircraft, and turn the camera off during take off and landing. In medical facilities, follow staff instructions regarding the use of wireless devices and satellite navigation systems.
- ⚠ **Do not remain in contact with the camera, battery, or charger for extended periods while the devices are on or in use.** Parts of the device become hot. Leaving the device in direct contact with the skin for extended periods may result in low-temperature burns.
- ⚠ **Do not leave the product where it will be exposed to extremely high temperatures, such as in an enclosed automobile or in direct sunlight.** Failure to observe this precaution could cause damage or fire.
- ⚠ **Do not aim the flash at the operator of a motor vehicle.** Failure to observe this precaution could result in accidents.
- ⚠ **Observe caution when using a flash.**
- Using the camera with the flash in close contact with the skin or other objects could cause burns.
 - Using a flash close to the subject's eyes could cause temporary visual impairment. The flash should be no less than one meter (3 ft 4 in.) from the subject. Particular care should be observed when photographing infants.
- ⚠ **Avoid contact with liquid crystal.** Should the display break, care should be taken to avoid injury due to broken glass and to prevent the liquid crystal from the display touching the skin or entering the eyes or mouth.
- ⚠ **Do not carry tripods with a lens or camera attached.** You could trip or accidentally strike others, resulting in injury.

⚠ Observe proper precautions when handling batteries. Batteries may leak or explode if improperly handled. Observe the following precautions when handling batteries for use in this product:

- Use only batteries approved for use in this equipment.
- Do not short or disassemble the battery.
- Be sure the product is off before replacing the battery. If you are using an AC adapter, be sure it is unplugged.
- Do not attempt to insert the battery upside down or backwards.
- Do not expose the battery to flame or to excessive heat.
- Do not immerse in or expose to water.
- Replace the terminal cover when transporting the battery. Do not transport or store the battery with metal objects such as necklaces or hairpins.
- Batteries are prone to leakage when fully discharged. To avoid damage to the product, be sure to remove the battery when no charge remains.
- When the battery is not in use, attach the terminal cover and store in a cool, dry place.
- The battery may be hot immediately after use or when the product has been used on battery power for an extended period. Before removing the battery turn the camera off and allow the battery to cool.
- Discontinue use immediately should you notice any changes in the battery, such as discoloration or deformation.

⚠ Observe proper precautions when handling the charger:

- Keep dry. Failure to observe this precaution could result in fire or electric shock.
- Do not short the charger terminals. Failure to observe this precaution could result in overheating and damage to the charger.
- Dust on or near the metal parts of the plug should be removed with a dry cloth. Continued use could result in fire.
- Do not go near the charger during thunderstorms. Failure to observe this precaution could result in electric shock.
- Do not handle the plug or charger with wet hands. Failure to observe this precaution could result in electric shock.
- Do not use with travel converters or adapters designed to convert from one voltage to another or with DC-to-AC inverters. Failure to observe this precaution could damage the product or cause overheating or fire.

⚠ Use appropriate cables. When connecting cables to the input and output jacks, use only the cables provided or sold by Nikon for the purpose to maintain compliance with product regulations.

⚠ CD-ROMs: CD-ROMs containing software or manuals should not be played back on audio CD equipment. Playing CD-ROMs on an audio CD player could cause hearing loss or damage the equipment.

Shock-, Water-, and Dust-Proofing

The product conforms to the following standards:

Shock-Proofing

The camera, with the special-purpose waterproof lens attached, has passed drop tests compliant ¹ with MIL-STD-810F Method 516.5: Shock. ² *These in-house tests do not constitute a blanket guarantee of invulnerability to damage or destruction.*

Water- and Dust-Proofing

With the special-purpose waterproof lens attached, the camera complies with the JIS IP68 waterproofing standard, allowing it to be used at depths of up to 15 m (49 ft) for as long as 60 minutes at a time. ³ *This is not a blanket guarantee that the product will be water- or dust-proof in all circumstances or invulnerable to damage or destruction.*

- 1 Using a test method derived from MIL-STD-810F Method 516.5: Shock, the product is dropped from a height of 200 cm (6.6 ft) onto a plywood surface 5 cm (2 in.) thick. Exterior deformation and surface damage are not tested.
- 2 An American military test standard that involves dropping 5 samples at a time from a height of 122 cm (4 ft) to test the effect of impact on a total of 26 surfaces (12 edges, 8 corners, and 6 faces), with the requirement that the test be passed within a total of 5 samples (if a problem occurs during the test, the test is repeated with 5 new samples, with the requirement that the test be passed within a total of 5 samples).
- 3 This signifies that according to tests performed using Nikon methods, the product can be used at the specified water pressure for the specified period of time.

Important: Waterproof Lenses

The product is not guaranteed shock-, water-, or dust-proof if the special-purpose waterproof lens is not attached. Before using this product, be sure to read the following sections, together with the instructions in “For Your Safety” (□ 7–9) and in “Caring for the Camera and Battery: Cautions” (□ 115–118). Before using the product underwater, read the cautions in “Underwater Photography” (□ 61–76).

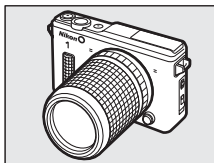

Precautions: Shock-Proofing

Observe the following precautions when using the camera with special-purpose waterproof lenses:

- The product is not guaranteed shockproof if the flash is raised.
- Do not intentionally subject the product to violent physical shocks, place it under heavy objects, or attempt to force it into bags or other spaces too small to contain it.
- Do not expose the product to depths greater than 15 m (49 ft) or to rapids, waterfalls, or other water under high pressure.
- Damage due to user error is not covered under warranty.



Precautions: Water- and Dust-Proofing

Observe the following precautions when using the camera with special-purpose waterproof lenses:

- Apart from the special-purpose waterproof lens, the accessories supplied with the camera are not waterproof. Special-purpose waterproof lenses are themselves waterproof only when attached to the camera.
- The product is proof only against fresh water (such as pools, rivers, and lakes) and seawater. Do not take into hot springs or baths.
- Do not expose to depths greater than 15 m (49 ft) or to rapids, waterfalls, water flowing at full force from a tap, or other water under high pressure. Failure to observe these precautions could expose the product to pressures high enough to cause water entry.
- Do not leave immersed for more than 60 minutes at a time.



- Internal parts will be damaged by water and dust. To prevent water entry, do not remove the lens, open the connector or battery-chamber/memory card slot cover, or operate the lens release button or the latches or security locks on the connector and battery-chamber/memory card slot covers with wet hands, when the camera is wet, or in locations exposed to spray, wind, sand or dust. Ensure that memory cards and batteries are dry before insertion. Should the product leak, cease use immediately, dry the camera and lens, and consult a Nikon-authorized service representative.

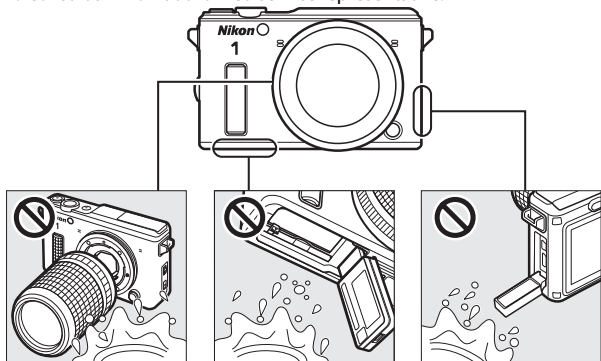

- Water and other liquids on the lens O-ring seal or inside the connector and battery-chamber/memory card slot covers should be removed immediately with a soft, dry cloth. Other foreign matter should be removed from these surfaces with a blower, taking care to remove any small particles from the sides and corners of the watertight channels. Foreign matter on the camera body can be removed with a soft, dry cloth. Do not use soap, cleansers, or other chemicals, and be sure to remove suntan oil, sunblock, bath salts, detergent, soap, organic solvents, oil, alcohol, and the like immediately.
- Do not leave the product for extended periods in locations that are exposed to freezing temperatures or temperatures over 50 °C (122 °F), such as in enclosed vehicles, on board boats, on the beach, in direct sunlight, or near heating equipment. Failure to observe this precaution may make the product vulnerable to water entry.

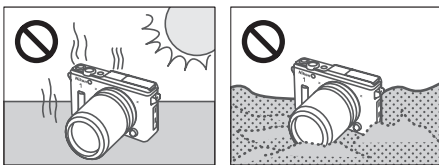

- The product is not guaranteed waterproof if struck, dropped, or otherwise subjected to strong pressure or violent physical shocks or vibration. If the product does suffer a fall or other physical shock, take it to Nikon-authorized service personnel and have it tested to make sure that it is still waterproof. Note that a fee will be charged for this service.
- Damage due to user error is not covered under warranty.

Operating Environment

The camera and special-purpose waterproof lenses have been tested and approved for use at temperatures between -10°C and $+40^{\circ}\text{C}$ ($+14^{\circ}\text{F}$ to 104°F) on land and 0°C and $+40^{\circ}\text{C}$ ($+32^{\circ}\text{F}$ to 104°F) in water. Note the following precautions:

- Battery performance drops at low temperatures. Keep the camera warm, or ready a spare battery and keep it in a warm location.
- At low temperatures, the monitor may not perform as expected immediately after the camera is turned on: for example, after-images may appear or the monitor may seem darker than normal.
- In cold environments, remove any snow or rain immediately. Buttons, switches, and other camera controls may become difficult to operate if allowed to freeze, while sound quality may be affected if water is allowed to accumulate in the holes in the microphone and speaker covers.
- Prolonged contact with cold metal can damage exposed skin. Wear gloves when handling the camera for extended periods at low temperatures.
- Select a dry location when attaching or removing special-purpose waterproof lenses, and avoid leaving the camera with the body cap removed or the battery-chamber/memory slot or connector cover open or the lens with the rear cap removed in humid locations. Failure to observe these precautions could result in condensation forming inside the lens when the product is taken into the water. Condensation may also form inside the lens, monitor, or watertight channel if the product is exposed to rapid changes in temperature, such as occur when the product is taken into cold water from a hot shore location, into a warm room from a cold exterior, or the battery-chamber/memory card slot cover is opened or closed or lenses are attached or removed in a humid location. Such condensation will not cause malfunction or other damage, and should dissipate if the product is first taken to a location with a stable temperature—free from heat, humidity, sand, and dust—and then turned off and left with the battery and memory card removed and the battery-chamber/memory card slot and connector covers open until it has reached the ambient temperature. Consult Nikon-authorized service personnel should the condensation fail to dissipate.

Important: Location Data (GPS/GLONASS)

Observe the following precautions when using the location data and track log features:

- **Track logs:** While **Yes** is selected for **Location data > Record location data** in the setup menu, location data will be recorded with all pictures taken and the camera will continue to monitor location data even while off. Radio waves produced by the device may affect medical equipment and aircraft navigation systems; in situations in which the use of satellite navigation devices is restricted or prohibited, such as in hospitals or aircraft, end the current track log, select **No** for **Record location data**, and turn the camera off.
- **Sharing location data:** Note that addresses and other personal information may be inferred from the location data stored in track logs or embedded in images. Exercise caution when sharing images and track logs or when posting them to the Internet or other locations where they can be viewed by third parties. See “Disposing of Data Storage Devices” (□ 18) for information on erasing location data before disposing of the camera or memory cards.
- **Navigation:** The position, altitude, depth, and other location data reported by the device are approximations only and are not intended for surveying or navigation. Be sure to take appropriate maps or other navigational devices with you when using the product during such outdoor activities as boating, diving, mountain climbing, or hiking.
- **Restrictions on use:** The location data function may not perform as expected in some countries or regions, including (as of October, 2013) China and in the vicinity of the Chinese border. Some countries prohibit unauthorized use of satellite navigation and other location data devices; before travelling, check with your travel agent or the embassy or tourism board of the countries you will be visiting. Where use is prohibited, select **No** for **Location data > Record location data**.

Notices

- No part of the manuals included with this product may be reproduced, transmitted, transcribed, stored in a retrieval system, or translated into any language in any form, by any means, without Nikon's prior written permission.
- Nikon reserves the right to change the specifications of the hardware and software described in these manuals at any time and without prior notice.
- Nikon will not be held liable for any damages resulting from the use of this product.
- While every effort has been made to ensure that the information in these manuals is accurate and complete, we would appreciate it were you to bring any errors or omissions to the attention of the Nikon representative in your area (address provided separately).

Notice for Customers in Canada

CAN ICES-3 B / NMB-3 B

Notice for Customers in Europe

CAUTION: RISK OF EXPLOSION IF BATTERY IS REPLACED BY AN INCORRECT TYPE. DISPOSE OF USED BATTERIES ACCORDING TO THE INSTRUCTIONS.

This symbol indicates that electrical and electronic equipment is to be collected separately.



The following apply only to users in European countries:

- This product is designated for separate collection at an appropriate collection point. Do not dispose of as household waste.
- Separate collection and recycling helps conserve natural resources and prevent negative consequences for human health and the environment that might result from incorrect disposal.
- For more information, contact the retailer or the local authorities in charge of waste management.

This symbol on the battery indicates that the battery is to be collected separately.



The following apply only to users in European countries:

- All batteries, whether marked with this symbol or not, are designated for separate collection at an appropriate collection point. Do not dispose of as household waste.
- For more information, contact the retailer or the local authorities in charge of waste management.

Notice for Customers in the U.S.A.

The Battery Charger

IMPORTANT SAFETY INSTRUCTIONS—SAVE THESE INSTRUCTIONS

DANGER—TO REDUCE THE RISK OF FIRE OR ELECTRIC SHOCK, CAREFULLY FOLLOW THESE INSTRUCTIONS

For connection to a supply not in the U.S.A., use an attachment plug adapter of the proper configuration for the power outlet if needed. This power unit is intended to be correctly oriented in a vertical or floor mount position.

Federal Communications Commission (FCC) Radio Frequency Interference Statement

This equipment has been tested and found to comply with the limits for a Class B digital device, pursuant to Part 15 of the FCC rules. These limits are designed to provide reasonable protection against harmful interference in a residential installation. This equipment generates, uses, and can radiate radio frequency energy and, if not installed and used in accordance with the instructions, may cause harmful interference to radio communications. However, there is no guarantee that interference will not occur in a particular installation. If this equipment does cause harmful interference to radio or television reception, which can be determined by turning the equipment off and on, the user is encouraged to try to correct the interference by one or more of the following measures:

- Reorient or relocate the receiving antenna.
- Increase the separation between the equipment and receiver.
- Connect the equipment into an outlet on a circuit different from that to which the receiver is connected.
- Consult the dealer or an experienced radio/television technician for help.



Nikon
1 AW1

CAUTIONS

Modifications

The FCC requires the user be notified that any changes or modifications made to this device that are not expressly approved by Nikon Corporation may void the user's authority to operate the equipment.

Interface Cables

Use the interface cables sold or provided by Nikon for your equipment. Using other interface cables may exceed the limits of Class B Part 15 of the FCC rules.

Notice for Customers in the State of California

WARNING: Handling the cord on this product may expose you to lead, a chemical known to the State of California to cause birth defects or other reproductive harm. *Wash hands after handling.*

Nikon Inc., 1300 Walt Whitman Road,
Melville, New York 11747-3064, U.S.A.
Tel.: 631-547-4200

Notice Concerning Prohibition of Copying or Reproduction

Note that simply being in possession of material that has been digitally copied or reproduced by means of a scanner, digital camera, or other device may be punishable by law.

• Items prohibited by law from being copied or reproduced

Do not copy or reproduce paper money, coins, securities, government bonds, or local government bonds, even if such copies or reproductions are stamped "Sample."

The copying or reproduction of paper money, coins, or securities which are circulated in a foreign country is prohibited.

Unless the prior permission of the government has been obtained, the copying or reproduction of unused postage stamps or post cards issued by the government is prohibited.

The copying or reproduction of stamps issued by the government and of certified documents stipulated by law is prohibited.

• Cautions on certain copies and reproductions

The government has issued cautions on copies or reproductions of securities issued by private companies (shares, bills, checks, gift certificates, etc.), commuter passes, or coupon tickets, except when a minimum of necessary copies are to be provided for business use by a company. Also, do not copy or reproduce passports issued by the government, licenses issued by public agencies and private groups, ID cards, and tickets, such as passes and meal coupons.

• Comply with copyright notices

The copying or reproduction of copyrighted creative works such as books, music, paintings, woodcuts, prints, maps, drawings, movies, and photographs is governed by national and international copyright laws. Do not use this product for the purpose of making illegal copies or to infringe copyright laws.

Disposing of Data Storage Devices

Please note that deleting images or formatting memory cards or other data storage devices does not completely erase the original image data. Deleted files can sometimes be recovered from discarded storage devices using commercially available software, potentially resulting in the malicious use of personal image data. Ensuring the privacy of such data is the user's responsibility.

Before discarding a data storage device or transferring ownership to another person, select **No** for **Location data** > **Record location data** and erase all data using commercial deletion software, or format the device and then completely refill it with images containing no private information (for example, pictures of empty sky). To remove track log data from the memory card, select **Delete log** and delete all logs. Care should be taken to avoid injury when physically destroying data storage devices.

AVC Patent Portfolio License

THIS PRODUCT IS LICENSED UNDER THE AVC PATENT PORTFOLIO LICENSE FOR THE PERSONAL AND NON-COMMERCIAL USE OF A CONSUMER TO (I) ENCODE VIDEO IN COMPLIANCE WITH THE AVC STANDARD ("AVC VIDEO") AND/OR (II) DECODE AVC VIDEO THAT WAS ENCODED BY A CONSUMER ENGAGED IN A PERSONAL AND NON-COMMERCIAL ACTIVITY AND/OR WAS OBTAINED FROM A VIDEO PROVIDER LICENSED TO PROVIDE AVC VIDEO. NO LICENSE IS GRANTED OR SHALL BE IMPLIED FOR ANY OTHER USE. ADDITIONAL INFORMATION MAY BE OBTAINED FROM MPEG LA, L.L.C. SEE <http://www.mpegla.com>

Temperature Warnings

The camera may become warm to the touch during use; this is normal and does not indicate a malfunction. At high ambient temperatures, after extended periods of continuous use, or after several photographs have been taken in quick succession, a temperature warning may be displayed, following which the camera will turn off automatically to minimize damage to its internal circuits. Wait for the camera to cool before resuming use.

Use Only Nikon Brand Electronic Accessories

Nikon cameras are designed to the highest standards and include complex electronic circuitry. Only Nikon brand electronic accessories (including chargers, batteries, AC adapters, and lens accessories) certified by Nikon specifically for use with this Nikon digital camera are engineered and proven to operate within the operational and safety requirements of this electronic circuitry.

The use of non-Nikon electronic accessories could damage the camera and may void your Nikon warranty. The use of third-party rechargeable Li-ion batteries not bearing the Nikon holographic seal shown at right could interfere with normal operation of the camera or result in the batteries overheating, igniting, rupturing, or leaking.



For more information about Nikon brand accessories, contact a local authorized Nikon dealer.

Use Only Nikon Brand Accessories

Only Nikon brand accessories certified by Nikon specifically for use with your Nikon digital camera are engineered and proven to operate within its operational and safety requirements. THE USE OF NON-NIKON ACCESSORIES COULD DAMAGE YOUR CAMERA AND MAY VOID YOUR NIKON WARRANTY.

Servicing the Camera and Accessories

The camera is a precision device and requires regular servicing. Nikon recommends that the camera be inspected by the original retailer or a Nikon-authorized service representative once a year, and that it be serviced once every three to five years (note that fees apply to these services). Frequent inspection and servicing are particularly recommended if the camera is used professionally. Any accessories regularly used with the camera, such as lenses, should be included when the camera is inspected or serviced.

Before Taking Important Pictures

Before taking pictures on important occasions (such as at weddings or before taking the camera on a trip), take a test shot to ensure that the camera is functioning normally. Nikon will not be held liable for damages or lost profits that may result from product malfunction.

Life-Long Learning

As part of Nikon's "Life-Long Learning" commitment to ongoing product support and education, continually-updated information is available on-line at the following sites:

- **For users in the U.S.A.:** <http://www.nikonusa.com/>
- **For users in Europe and Africa:** <http://www.europe-nikon.com/support/>
- **For users in Asia, Oceania, and the Middle East:** <http://www.nikon-asia.com/>

Visit these sites to keep up-to-date with the latest product information, tips, answers to frequently-asked questions (FAQs), and general advice on digital imaging and photography. Additional information may be available from the Nikon representative in your area. For contact information, visit <http://imaging.nikon.com/>

Introduction

Package Contents

Confirm that the package contains the following items:



- BF-N2000 body cap
- PA-N1000 O-ring protector

- Nikon 1 AW1 digital camera (comes with WP-O2000 O-ring attached; check O-ring for damage before use)

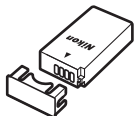

- EN-EL20 rechargeable Li-ion battery (with terminal cover)



- MH-27 battery charger (AC wall adapter supplied in countries or regions where required; shape depends on country of sale)



- Lens (supplied only if lens kit is purchased with camera; comes with front and rear lens caps)

- AN-N1000 strap (intended exclusively for use on land)

- ViewNX 2/Short Movie Creator CD

- Reference manual CD (contains the Reference Manual)

- Silicon grease

- Warranty
- User's Manual

- UC-E19 USB cable

- (this manual)

Memory cards are sold separately.

Parts of the Camera

Take a few moments to familiarize yourself with camera controls and displays. You may find it helpful to bookmark this section and refer to it as you read through the rest of the manual.

The Camera Body

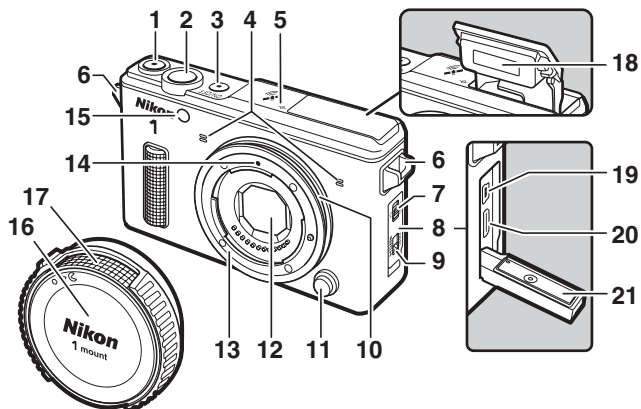

1 Movie-record button77, 79, 84	12 Dust shield 114, 115
2 Shutter-release button 42, 80	13 Lens mount
3 Power switch.....36	14 Mounting mark 34
Power lamp36	15 AF-assist illuminator
4 Microphone	Self-timer lamp89
5 Focal plane mark (∅)	Red-eye reduction lamp92
6 Eyelet for camera strap.....31	16 Body cap108
7 Connector cover latch105	17 O-ring protector.....110
8 Connector cover105	18 Built-in flash.....91
9 Connector cover security lock105	19 USB connector.....105
10 O-ring 33, 73, 108	20 HDMI mini-pin connector
11 Lens release button.....35	21 Watertight channel62

The Camera Body (Continued)

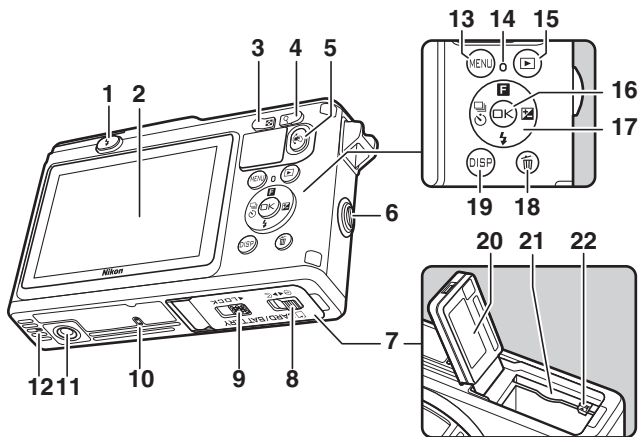

1 Flash pop-up button.....	91	13 MENU (menu) button	26
2 Monitor	24, 36	14 Memory card access lamp	43
3 (playback zoom out/thumbnail) button	44	15 (playback) button	44
4 (playback zoom in) button.....	44	16 (OK) button	30
5 (action) button	95	17 Multi selector.....	30
6 Grip attachment screw		F (feature)	29
7 Battery-chamber/ memory card slot cover	32	(exposure compensation)	
8 Battery-chamber/memory card slot cover latch	32	(flash mode).....	91, 92
9 Battery-chamber/memory card slot cover security lock.....	32	(continuous shooting/ self-timer).....	87, 89
10 Speaker		18 (delete) button.....	45, 82
11 Tripod socket *		19 DISP (display) button	25
12 Pressure equalization vent		20 Watertight channel	62
		21 Memory card slot.....	32
		22 Battery latch.....	32

* Camera does not support TA-N100 tripod mounting spacer.

The Multi Selector

To navigate the menus, press the multi selector up, down, left, or right (▲, ▼, ◀, or ▶) as shown below.

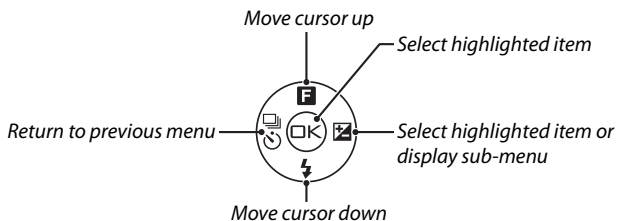

Holding the Camera

When framing photographs, hold the camera as shown below.

Hold the camera in your right hand.

Keep your elbows propped lightly against your torso.

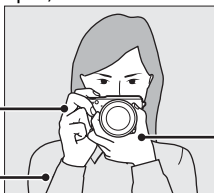

Cradle the lens with your left hand.



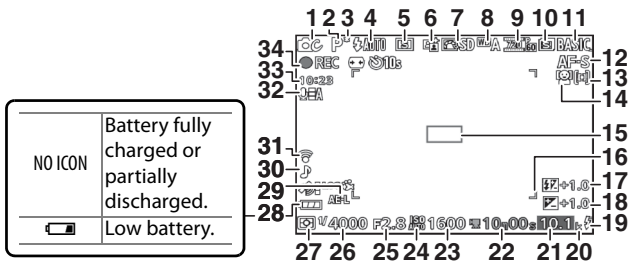

1 Shooting mode 27	19 Flash-ready indicator 91
2 Live image control 47	20 "K" (appears when memory remains for over 1000 exposures)
Creative mode 49	21 Number of exposures remaining 39
Best moment capture selection	Number of shots remaining before memory buffer fills
Advanced movie selection 77, 83	White balance recording indicator
Exposure mode 99	Card warning indicator 121
3 Flexible program indicator 52	22 Time available 79, 84
4 Flash mode 92	23 ISO sensitivity 100
5 Continuous mode ¹ 87	24 ISO sensitivity indicator 100
6 Active D-Lighting ¹ 99	Auto ISO sensitivity indicator
7 Picture Control ¹ 100	25 Aperture 54, 55
8 White balance ¹ 100	26 Shutter speed 53, 55
9 Movie settings (HD movies) ¹ 100	27 Metering 99
Frame rate	28 Battery indicator ^{1, 2}
(slow-motion movies) ¹ 100	29 Autoexposure (AE) lock indicator
10 Image size ¹ 99	30 Sound settings ¹ 101
11 Image quality ¹ 99	31 Eye-Fi connection indicator ¹
12 Focus mode ¹ 99, 100	32 Microphone sensitivity ¹
13 AF-area mode ¹ 99, 100	33 Time elapsed 79, 84
14 Face-priority ¹ 46, 99	34 Recording indicator 79, 84
15 Focus area 42, 99, 100	
16 AF-area brackets ¹	
17 Flash compensation 99	
18 Exposure compensation	

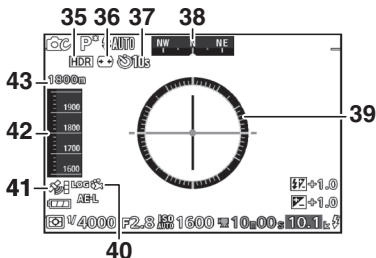

- | | |
|--|---|
| 35 HDR57 | 40 Track log indicator ^{1,2} |
| 36 Auto distortion control.....99 | 41 Satellite signal indicator ^{1,2} |
| 37 Self-timer89 | 42 Altimeter/depth gauge ²68, 101 |
| 38 Heading ² | 43 Altitude/depth ²68, 101 |
| 39 Virtual horizon ² | |

1 Shown in detailed display.

2 Shown in altimeter, depth gauge, heading, and virtual horizon display.

The DISP (Display) Button

Press DISP to cycle through shooting or playback indicators.

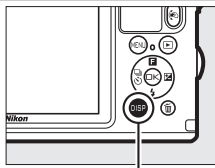

DISP button

See Also

For information on adjusting monitor brightness, see page 100.

The MENU Button

The shooting mode and most shooting, playback, and setup options can be accessed from the camera menus. Press the MENU button to display the menu selection dialog shown below, then use the multi selector to highlight the icon for the desired menu and press **OK**.

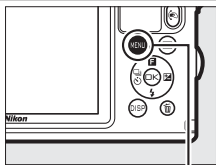

MENU button

Playback menu (☞ 98):

Adjust playback settings.

Shooting menu (☞ 99):

Adjust settings for still photography.

Shooting mode

menu (☞ 27):

Choose a shooting mode.



Movie menu (☞ 100):

Adjust movie-recording options.

Setup menu (☞ 100):

Adjust basic camera settings.

Image processing menu (☞ 100):

Adjust white balance, ISO sensitivity, Picture Controls, and other image processing settings for photographs and movies.

■ Choosing a Shooting Mode

To display the shooting mode menu, press the MENU button, highlight **Shooting mode**, and press \odot . Use the multi selector to highlight a shooting mode and press \odot to select the highlighted option.

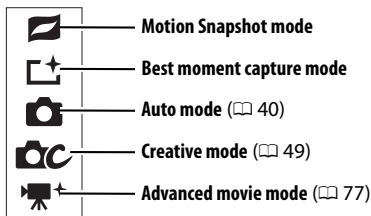
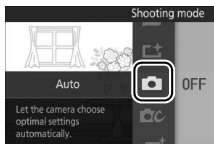

Options for each mode can be displayed by highlighting the mode and pressing \blacktriangleright . Press \blacktriangleleft to return to the shooting mode menu.



■ **Motion Snapshot mode:** Choose a theme for Motion Snapshots, which combine photographs with brief movie vignettes.

- **Beauty (1)**
- **Waves (2)**

- **Relaxation (3)**
- **Tenderness (4)**

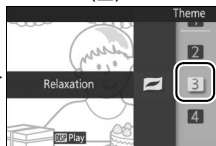
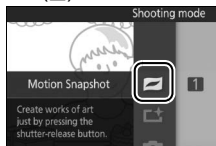

■ The \odot Button

When the view through the lens is displayed in the monitor, you can also select the shooting mode by holding the \odot button, tilting the camera left or right to highlight the desired option, and then releasing the button (page 95).



Best moment capture mode: Select **Slow view** to choose the timing for a shot as the scene plays back in slow motion, or choose **Smart Photo Selector** to let the camera automatically pick the best shot based on motion and composition.

- **Slow view** (🎬)
- **Smart Photo Selector** (📷)

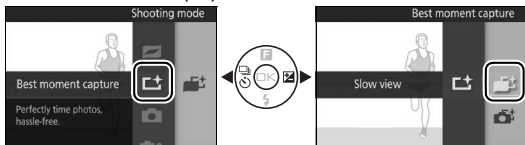

Auto mode: Take photographs using live controls (📖 47).

- **Active D-Lighting** (☀️)
- **Motion control** (👤)
- **Background softening** (🏡)
- **Brightness control** (🔆)

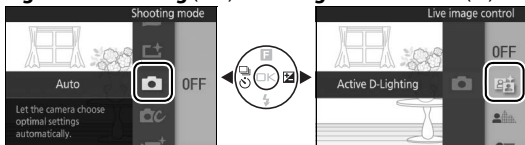

Creative mode: Choose a scene (📖 49).

- **Programmed auto (P)**
- **Shutter-priority auto (S)**
- **Aperture-priority auto (A)**
- **Manual (M)**
- **Underwater** (🌊, 🐠, 🌊)
- **Night portrait** (🌃)
- **Backlighting** (🌅)
- **Easy panorama** (📷)
- **Soft** (🌿)
- **Miniature effect** (🏠)
- **Selective color** (🖌️)



🎬+ Advanced movie mode: Choose between HD (📖 77) and slow-motion movies (📖 83).

- **Programmed auto (P)**
- **Shutter-priority auto (S)**
- **Aperture-priority auto (A)**

- **Manual (M)**
- **Slow motion (🎬)**

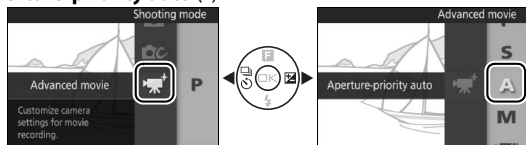

🔍 F (Feature)

The options for each mode can also be displayed by pressing **▲ (F)** on the multi selector after selecting the shooting mode.

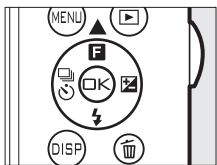

■ Using the Menus

Use the multi selector to navigate the playback, shooting, movie, image processing, and setup menus.

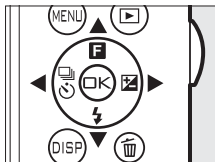

Multi selector

1 Select an item.

Press ▲ or ▼ to highlight menu items and press ► to view options for the highlighted item.

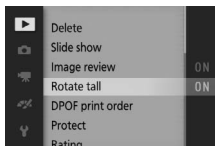

2 Select an option.

Press ▲ or ▼ to highlight the desired option and press  to select.

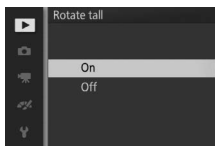

Using the Menus

The items listed may vary with camera settings. Items displayed in gray are not currently available. To exit the menus and return to shooting mode, press the shutter-release button halfway ( 42).

Choosing a Menu

To display another menu, press ◀ in Step 1 and then press ▲ or ▼ to highlight the desired icon. Press ► to position the cursor in the highlighted menu.

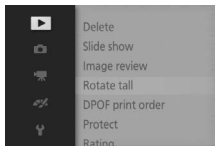

First Steps

1 Attach the strap.

The AN-N1000 strap supplied with the camera is exclusively for use on land. Attach the strap securely to the two camera eyelets.

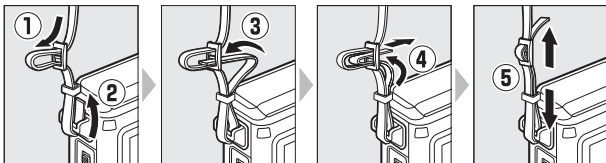

Remove the AN-N1000 before using the camera underwater. A hand strap (available separately from third-party suppliers) is recommended to prevent loss when the camera is used underwater.

2 Charge the battery.

Insert the battery into the charger ① and plug the charger in ②. An exhausted battery fully charges in about two hours. Unplug the charger and remove the battery when charging is complete.

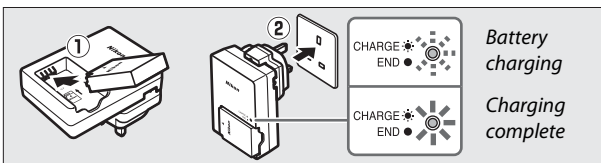

The Plug Adapter

Depending on the country or region of purchase, a plug adapter may be supplied with the charger. The shape of the adapter varies with the country or region of purchase. If a plug adapter is supplied, raise the wall plug and connect the plug adapter as shown at right, making sure the plug is fully inserted. Attempting to forcibly remove the plug adapter could damage the product.

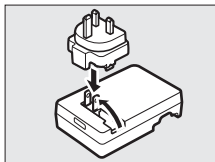

3 Insert the battery and a memory card.

Undo the battery-chamber/memory card slot cover security lock (1) and unlatch (2) and slowly open the cover (3). After checking that they are in the correct orientation, insert the battery and memory card as follows: using the battery to keep the orange battery latch pressed to one side, slide the battery in until it latches (4), and then slide in the memory card until it clicks into place (5). Close (6), latch (7), and lock (8) the cover, and confirm that the latch and security lock are in the positions shown (A).

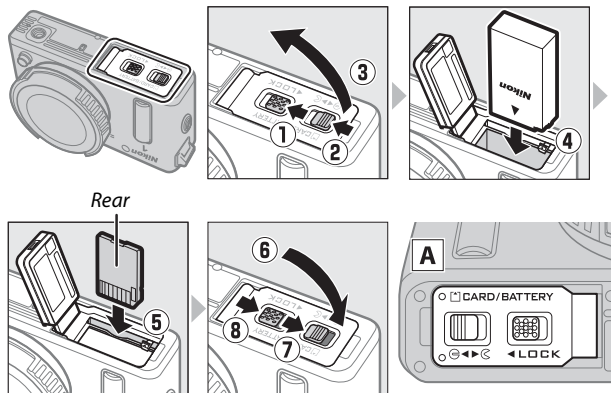

Formatting Memory Cards

If this is the first time the memory card will be used in the camera or if the card has been formatted in another device, select **Format memory card** in the setup menu and follow the on-screen instructions to format the card (100). *Note that this permanently deletes any data the card may contain.* Be sure to copy any photographs and other data you wish to keep to a computer before proceeding (105).

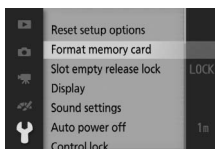

4 Attach the special-purpose waterproof lens.

The camera is used with special-purpose waterproof lenses that attach as shown below (for information on attaching non-waterproof 1 NIKKOR lenses, see page 110). The lens generally used in this manual for illustrative purposes is a 1 NIKKOR AW 11–27.5mm f/3.5–5.6. When attaching the lens, care should be taken to avoid damage to the camera and lens and to ensure that dust and other foreign matter does not enter the camera or adhere to the O-ring or surrounding area.

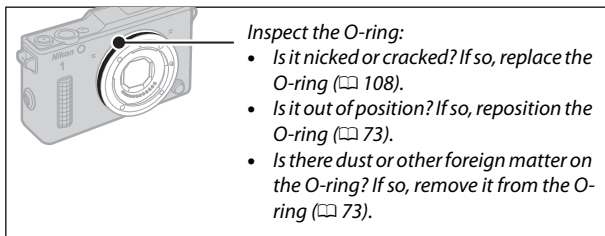
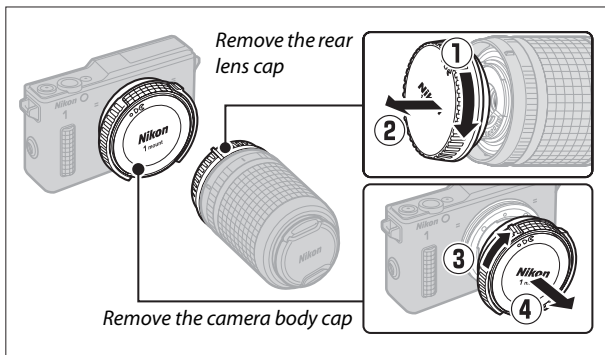

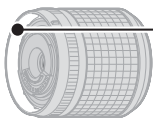

Check the lens: Remove any dust or other foreign matter from the lens O-ring seal (☞ 73).

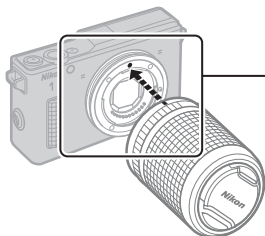

Align the mounting marks

Mounting mark (camera)

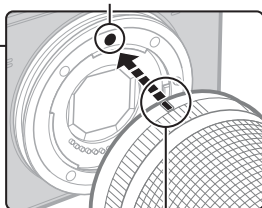

Mounting mark (lens)

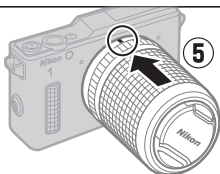

Place the lens over the O-ring and press it into position

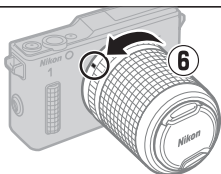

Rotate the lens as shown until it stops

When placing the lens over the O-ring, be careful not to damage the camera or lens; do not use excessive force.

Detaching the Waterproof Lenses

Be sure the camera is off when removing or exchanging lenses. To remove the lens, press and hold the lens release button (①) while rotating the lens as shown (②) and then detach the lens from the camera. After removing the lens, replace the lens caps and camera body cap.

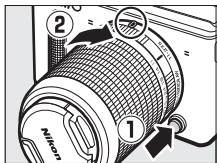

Attaching and Removing Waterproof Lenses

Before attaching or removing a waterproof lens, be sure the lens and camera are completely dry, that the O-ring is not cracked, damaged, twisted, or out of position, and that the camera O-ring and lens O-ring seal are free of hair, dust, sand, and other foreign objects. Do not exchange lenses when your hands are wet or have salt on them or in areas exposed to wind, spray, dust, or sand, and be careful that water does not drop into the interior of the camera or lens.

Silicon Grease

The O-ring can be lubricated with the supplied silicon grease or with optional WP-G1000 silicon grease, preventing wear and making waterproof lenses easier to attach and remove (□ 108). To apply, place a bead of grease in a plastic bag and use your fingers to spread the grease throughout the bag (①), then insert the O-ring and massage the bag to coat the ring (②). *Use only silicon grease designated for use with this product.* Failure to observe this precaution could result in O-ring becoming stretched or otherwise deformed.

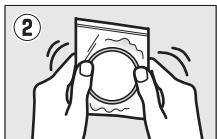

5 Turn the camera on.

Press the power switch to turn the camera on. The power lamp will briefly light green and the monitor will turn on. Be sure to remove the lens cap before shooting.

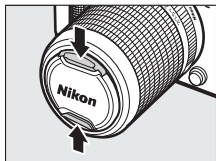
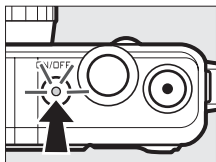

Turning the Camera Off

To turn the camera off, press the power switch again. The monitor will turn off.

6 Choose a language.

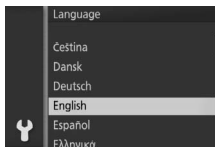

A language-selection dialog will be displayed the first time the camera is turned on. Use the multi selector and  button to choose a language.





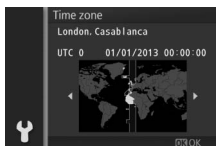

7 Set the clock.

Use the multi selector and  button (📖 22) to set the time and date. *Note that the camera uses a 24-hour clock.*

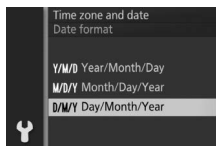



Press  or  to highlight time zone and press .



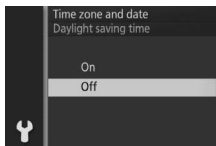



Press  or  to highlight date format and press .

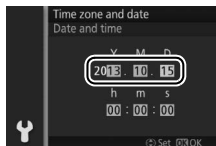





Press  or  to highlight daylight saving time option and press .

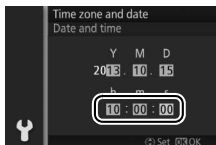

Press  or  to select year, month, or date and press  or  to change. Press  to proceed.



Press  or  to select hour, minute, or second and press  or  to change. Press  when finished.

Note: Language and clock can be changed at any time using **Language** (📖 101) and **Time zone and date** (📖 101) options in setup menu.



8 Read the instructions on keeping your camera watertight.

Once the clock is set, the camera will display a series of messages on maintaining a watertight seal, which you are encouraged to read before using the camera for the first time. Press ◀ or ▶ to scroll through the messages. To exit, press  when the last message is displayed.

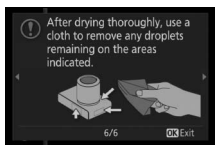
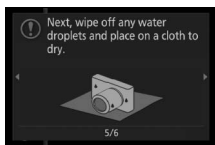
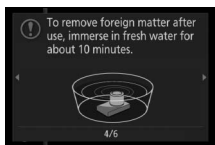
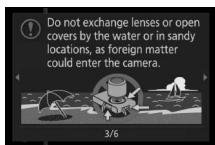
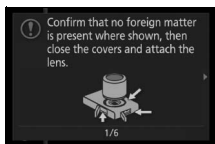

Note

If you remove and reinsert the battery, the first of these messages may be displayed again for a few seconds. To view all messages, press **DISP** while the first message is displayed and then press ◀ or ▶ to scroll through the remaining messages. To exit, press .

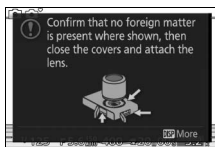

9 Check the battery level and memory card capacity.

Check the battery level and number of exposures remaining in the monitor (📖 24).

Battery level

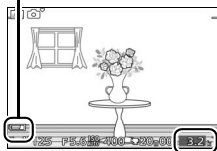

Exposures remaining



Taking and Viewing Photographs

The camera gives you a choice of auto mode for “point-and-shoot” photography that leaves the camera in charge of choosing settings, creative mode, which lets you adjust settings according to your subject or creative intent, and a variety of other modes for hard-to-time shots or to capture the emotion surrounding special moments.

Point-and-Shoot Photography (Auto Mode)



Follow the steps below to take photographs in auto mode, a “point-and-shoot” mode in which the camera automatically detects the subject type and adjusts settings according to the subject and situation.

1 Turn the camera on.

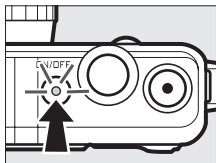
Press the power switch to turn the camera on.



2 Select mode.

Press the MENU button to display the menus. Select **Shooting mode**, then highlight  (auto) and press  (27).

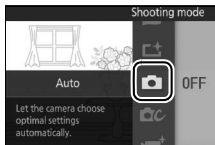

3 Ready the camera.

Hold the camera securely with both hands, being careful not to obstruct the lens, AF-assist illuminator, or microphone. Rotate the camera as shown at lower right when taking pictures in "tall" (portrait) orientation.

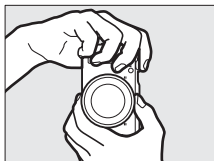
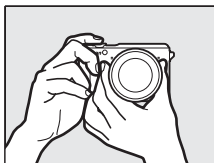

4 Frame the photograph.

Position your subject in the center of the frame.

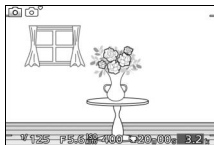

Using a Zoom Lens

Use the zoom ring to zoom in on the subject so that it fills a larger area of the frame, or zoom out to increase the area visible in the final photograph (select longer focal lengths on the lens focal length scale to zoom in, shorter focal lengths to zoom out).

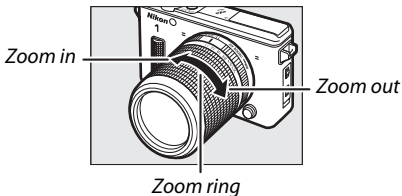

5 Focus.

Press the shutter-release button halfway to focus. If the subject is poorly lit, the AF-assist illuminator (21) may light to assist the focus operation.



If the camera is able to focus, the selected focus area will be highlighted in green and a beep will sound (a beep may not sound if the subject is moving).

If the camera is unable to focus, the focus area will be displayed in red.

Focus area

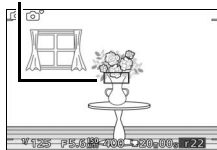

6 Shoot.

Smoothly press the shutter-release button the rest of the way down to release the shutter and record the photograph. The memory card access lamp will light and the photograph will be displayed in the monitor for a few seconds (the photo will automatically clear from the display when the shutter-release button is pressed halfway). *Do not eject the memory card or remove the battery until the lamp has gone out and recording is complete.*

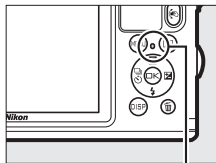
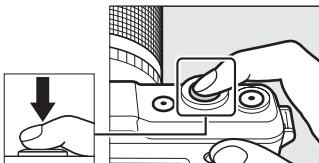

Memory card access lamp

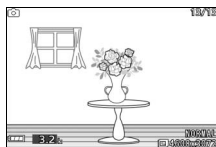

The Framing Grid

A framing grid can be displayed by selecting **On** for **Display > Grid display** in the setup menu (☰ 100).

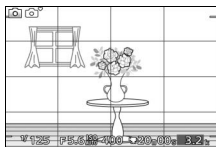

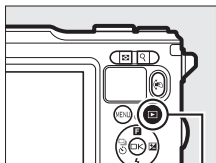

Viewing Photographs

Press  to display your most recent photograph full frame in the monitor (full-frame playback).



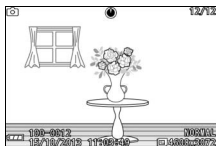

 button



Press  or  to view additional pictures.



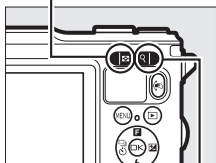

To zoom in on the current picture, press  **Q**. To view multiple pictures, press  when a picture is displayed full frame.



 button

To end playback and return to shooting mode, press the shutter-release button halfway.

The Button

During playback, you can also select pictures for display by holding the  button, tilting the camera left or right to highlight the desired image, and then releasing the button to display the highlighted picture full frame ( 96).

See Also

See page 98 for slide show options.

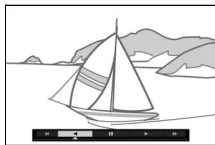

Deleting Pictures

To delete the current picture, press . Note that once deleted, pictures can not be recovered.

1 Display the photograph.

Display the photograph you wish to delete as described on the preceding page.

2 Press .

A confirmation dialog will be displayed.

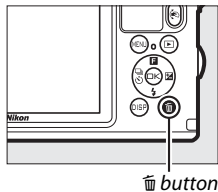

3 Delete the photograph.

Press again to delete the picture and return to playback, or press to exit without deleting the picture.

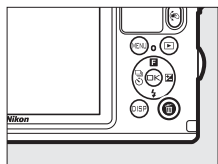

Deleting Multiple Pictures

The **Delete** option in the playback menu (98) can be used to delete all or selected pictures.



Face Priority

The camera detects and focuses on portrait subjects (face priority). A double yellow border will be displayed if a portrait subject is detected facing the camera (if multiple faces, up to a maximum of five, are detected, the camera will select the closest subject). Press the shutter-release button halfway to focus on the subject in the double yellow border. The border will clear from the display if the camera can no longer detect the subject (because, for example, the subject has looked away).





Automatic Scene Selection

In auto mode, the camera automatically analyzes the subject and selects the appropriate scene. The selected scene is shown in the monitor.

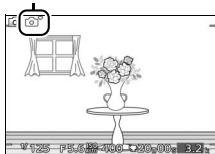
Scene icon





 **Portrait:** Human portrait subjects.

 **Landscape:** Landscapes and cityscapes.

 **Night portrait:** Portrait subjects framed against dark backgrounds.

 **Close up:** Subjects close to the camera.



 **Night landscape:** Poorly-lit landscapes and cityscapes.

 **Auto:** Subjects that do not fall into the categories listed above.

Auto Power Off

If no operations are performed for about a minute, the display will turn off and the power lamp start to flash. The camera can be reactivated by operating the shutter-release button. If no operations are performed for about three minutes after the display has turned off, the camera will turn off automatically.

Live Image Control

Live image controls let you adjust settings without leaving the shooting display, allowing you to preview how the changes will affect your photographs. To view the live image controls available in auto mode, press ▲ (F). Highlight a control and press  to select, then press ▲ or ▼ to adjust the control and press  to return to shooting mode. To cancel the control, press ▲ (F) again.



Active D-Lighting: Preserve details in highlights and shadows for natural contrast.



Active D-Lighting: High *Active D-Lighting: Low*

Background softening: Soften background details to make your subject stand out, or bring both background and foreground into focus.



Background sharp

Background softened

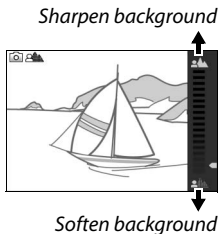
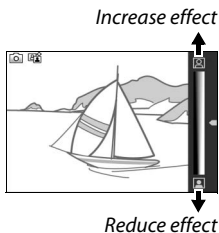

Motion control: Suggest motion by blurring moving objects, or “freeze” motion to capture moving objects clearly.



Freeze motion

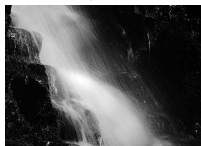

Blur motion

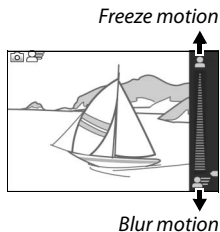

Brightness control: Make pictures brighter or darker.



Brighter

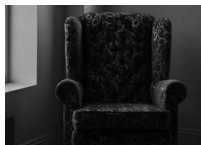

Darker

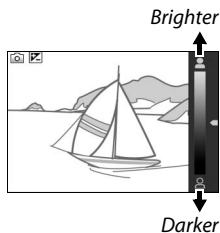



Live Image Control

Continuous shooting is not available (87) and the built-in flash can not be used when live image control is in effect. Pressing the movie-record button cancels live image control.

Choosing a Creative Mode

Choose creative mode to match settings to the subject or situation, take photos using special effects, or control shutter speed and aperture.

1 Select mode.

Press the MENU button to display the menus. Select **Shooting mode**, then highlight  (creative mode) and press  (book 27).



2 Choose a scene.

Press  (**F**) and highlight a scene using the multi selector (book 50).

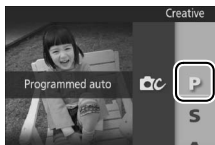

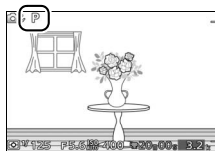

Press  to select the highlighted scene. Your selection is indicated by an icon in the display.





Choosing a Mode That Matches the Subject or Situation

Choose a creative mode according to the subject or situation:

Option	Description
Programmed auto (P)	The camera sets shutter speed and aperture for optimal exposure (□ 52). Recommended for snapshots and in other situations in which there is little time to adjust camera settings.
Shutter-priority auto (S)	You choose the shutter speed; the camera selects an aperture for best results (□ 53). Use to freeze or blur motion.
Aperture-priority auto (A)	You choose the aperture; the camera selects a shutter speed for best results (□ 54). Use to blur the background or bring both foreground and background into focus.
Manual (M)	You control both shutter speed and aperture (□ 55).
Underwater ()	Take pictures under water (□ 65, 66).
Night landscape ()	Capture low lighting in night scenes. Each time the shutter-release button is fully pressed, the camera takes a series of shots and combines them; during processing, a message is displayed and no pictures can be taken. The flash does not fire and the edges of photos are cropped out. Note that the desired results may not be obtained if the camera or subject moves during shooting; if the camera is unable to combine the images, a warning will be displayed and only one picture will be taken.

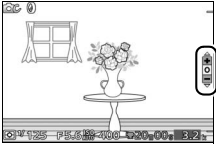

Option	Description
Night portrait (📷)	Capture background lighting in portraits taken at night or under low light. Each time the shutter-release button is fully pressed, the camera takes a series of shots, some with the flash and some without, and combines them; during processing, a message is displayed and no pictures can be taken. Raise the built-in flash before shooting; no photograph will be taken if the flash is not raised. Note that the edges of photos are cropped out and that the desired results may not be obtained if the camera or subject moves during shooting; if the camera is unable to combine the images, a warning will be displayed and the camera will take a single picture using the flash.
Backlighting (📷)	Photograph backlit subjects (📖 57).
Easy panorama (📷)	Shoot panoramas for later viewing on the camera (📖 58).
Soft (📷)	Shoot photographs with a soft filter effect. To choose the amount of softening, press OK when the view through the lens is displayed, highlight an option using the multi selector, and press OK to select. 
Miniature effect (📷)	The top and bottom of each photo is blurred so that the subject appears to have been a diorama photographed at short range. Works best when shooting from a high vantage point.
Selective color (📷)	Take photos in which only a selected hue appears in color. To choose the hue, press OK when the view through the lens is displayed and use the multi selector and OK button. 

Taking Photos in P, S, A, and M Modes

P, S, A, and M modes offer varying degrees of control over shutter speed and aperture. Choose a mode and adjust settings according to your creative intent.

■ P Programmed Auto

In this mode, the camera automatically adjusts shutter speed and aperture for optimal exposure in most situations. This mode is recommended for snapshots and other situations in which you want to leave the camera in charge of shutter speed and aperture.

✍ Choosing a Combination of Shutter Speed and Aperture

Although the shutter speed and aperture chosen by the camera will produce optimal results, you can also choose from other combinations that will produce the same exposure (“flexible program”). Press **Q** for large apertures (low f-numbers) that blur background details or fast shutter speeds that “freeze” motion, **☒** for small apertures (high f-numbers) that increase depth of field or slow shutter speeds that blur motion. ***** is displayed while flexible program is in effect.

☒ button

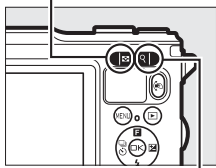

Q button

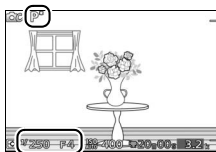

✍ Restoring Default Shutter Speed and Aperture Settings

To restore default shutter speed and aperture settings, press **Q** or **☒** until ***** is no longer displayed or turn the camera off. The default shutter speed and aperture is automatically restored when the camera enters standby mode.

■ S Shutter-Priority Auto

In shutter-priority auto, you choose the shutter speed while the camera automatically selects the aperture that will produce the optimal exposure. Use slow shutter speeds to suggest motion by blurring moving subjects, fast shutter speeds to “freeze” motion.



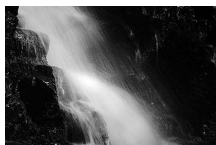

Fast shutter speed ($1/1600$ s)



Slow shutter speed (1 s)



Choosing a Shutter Speed

Use the **Q** and  buttons to choose from shutter speeds between 30 s and $1/16,000$ s. Press **Q** for faster shutter speeds,  for slower shutter speeds.

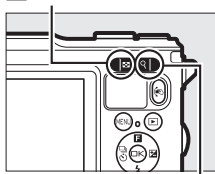

Q button

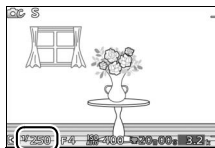

Continuous Shooting

The selected shutter speed may change if the frame rate for continuous shooting ( 87) is 15 fps or more.



■ A Aperture-Priority Auto

In aperture-priority auto, you choose the aperture while the camera automatically selects the shutter speed that will produce the optimal exposure. Large apertures (low f-numbers) reduce depth of field, blurring objects behind and in front of the main subject. Small apertures (high f-numbers) increase depth of field, bringing out details in the background and foreground. Short field depths are generally used in portraits to blur background details, long field depths in landscape photographs to bring the foreground and background into focus.





Large aperture (f/5.6)



Small aperture (f/16)

Choosing an Aperture

Press  for larger apertures (lower f-numbers),  for smaller apertures (higher f-numbers).

 button

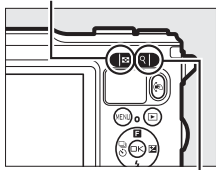

Q button

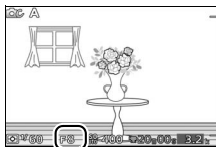

■ ■ M Manual

In manual mode, you control both shutter speed and aperture.

Choosing Shutter Speed and Aperture

Adjust shutter speed and aperture with reference to the exposure indicator (see below). Press **▶** to highlight shutter speed or aperture and use the **Q** and **⊞** buttons to choose a value, then repeat for the remaining item. Press **Q** for faster shutter speeds or smaller apertures (higher f-numbers), **⊞** for slower shutter speeds and larger apertures (lower f-numbers). Shutter speeds can be set to values as fast as $\frac{1}{16,000}$ s or as slow as 30 s, or to “Bulb” to hold the shutter open indefinitely for a long time-exposure.



⊞ button

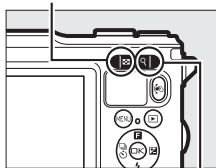

Q button

Shutter speed

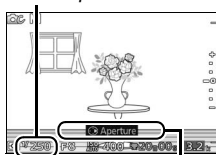

Press **▶** to highlight aperture.

Aperture



Press **▶** to highlight shutter speed.



The Exposure Indicator

When shutter speeds other than “Bulb” are selected, the exposure indicator shows whether the photograph would be under- or over-exposed at current settings.

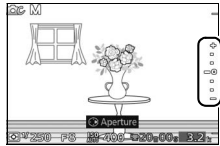

Optimal exposure	Underexposed by $\frac{1}{3}$ EV	Overexposed by over 2 EV
+ . . - 0 . . -	+ . . = 0 . . -	+ ▲ -

Backlighting

The method used to capture details in shaded areas of back-lit subjects depends on the option selected for **HDR** in the shooting menu (📖 99).

On	<p>Details in highlights and shadows are preserved using HDR (high dynamic range); HDR appears in the display. Each time the shutter-release button is fully pressed, the camera takes two shots in quick succession and combines them to preserve details in highlights and shadows in high-contrast scenes; the built-in flash does not fire. While the shots are combined, a message will be displayed and the shutter release will be disabled. The final photograph will be displayed when processing is complete.</p> <div data-bbox="170 502 937 728"><p>The diagram illustrates the HDR process. It shows three rectangular frames. The first frame on the left is labeled 'First exposure (darker)' and shows a view through a window with a tall building in the distance. The second frame in the middle is labeled 'Second exposure (brighter)' and shows the same view but with more detail in the shadows. A plus sign is between the first and second frames. An arrow points from the second frame to the third frame on the right, labeled 'Combined HDR image', which shows a balanced exposure with details from both the first and second exposures.</p></div>
Off	<p>The flash fires to “fill in” (illuminate) shadows in back-lit subjects. Only one shot is taken when the shutter-release button is fully pressed, and the flash fires with each shot. No pictures will be taken if the built-in flash is not raised; raise the flash before shooting.</p>

Framing HDR Photographs

The edges of the image will be cropped out. The desired results may not be achieved if the camera or subject moves during shooting. Depending on the scene, shading may be uneven and shadows may appear around bright objects or halos around dark objects. If the camera is unable to successfully combine the two images, a single image will be recorded at normal exposure and Active D-Lighting (📖 99) will be applied.



Easy Panorama

Follow the steps below to shoot panoramas. During shooting, the camera focuses using auto-area AF; face detection is not available. Exposure compensation can be used, but the built-in flash will not fire.

1 Set focus and exposure.

Frame the start of the panorama and press the shutter-release button halfway. Guides will appear in the display.

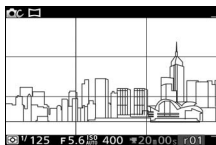

2 Start shooting.

Press the shutter-release button the rest of the way down and then lift your finger from the button. \triangle , ∇ , \triangleleft , and \triangleright icons will appear in the display to indicate the possible pan directions.



3 Pan the camera.

Slowly pan the camera up, down, left, or right as shown below. Shooting will start when the camera detects the pan direction and a progress indicator will appear in the display. Shooting ends automatically when the end of the panorama is reached.

Progress indicator



An example of how to pan the camera is shown below. Without changing your position, pan the camera in a steady curve either horizontally or vertically. Time the pan according to the option selected for **Image size** in the shooting menu: about 15 seconds are needed to complete the pan when **STD Normal panorama** is selected, about 30 seconds when **WIDE Wide panorama** is selected.

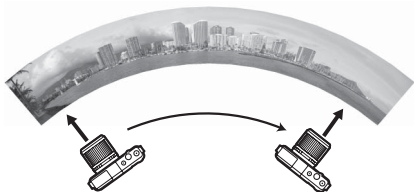



Panoramias

High-distortion wide-angle lenses may fail to produce the desired results. An error message will be displayed if the camera is panned too quickly or unsteadily.

The completed panorama will be slightly smaller than the area visible in the display during shooting. No panorama will be recorded if shooting ends before the halfway point; if shooting ends after the halfway point but before the panorama is complete, the unrecorded portion will be shown in gray.





■ Viewing Panoramas

Panoramas can be viewed by pressing  when a panorama is displayed full frame ( 44). The start of the panorama will be displayed with the smallest dimension filling the display and the camera will then scroll through the picture in the original pan direction.



Navigation Guide window

The following operations can be performed:

To	Use	Description
Pause		Pause playback.
Play		Resume playback when the panorama is paused or during rewind/advance.
Advance/ rewind		Press ◀ to rewind, ▶ to advance. If playback is paused, the panorama rewinds or advances a segment at a time; keep the button pressed for continuous rewind or advance.
Return to full-frame playback	 / 	Press ▲ or ▶ to exit to full-frame playback.

Underwater Photography

With a special-purpose waterproof lens attached, the camera can be used at depths of up to 15 m (49 ft) for as long as 60 minutes at a time. Before using the camera under water, be sure that you have read and understood the instructions in this section and have removed straps intended exclusively for use on land (hand straps, available separately from third-party suppliers, are recommended to prevent loss during underwater use).



Important: Precautions

To prevent water entry or other damage, observe the following precautions when using the camera underwater:

- Be sure a special-purpose waterproof lens is attached. The camera is not waterproof when a waterproof lens is not attached, while waterproof lenses are only waterproof when attached to the camera. Do not expose the camera to water when a waterproof lens is not attached nor waterproof lens to water when not attached to the camera.
- The sudden change in temperature caused by taking the camera into the water after it has been left on the beach, in direct sunlight, or in other locations exposed to high temperatures could result in water droplets forming inside the camera or lens, potentially damaging the products.
- Do not remove the lens under water, open the connector or battery-chamber/memory card slot cover, or operate the lens release button or the latches or security locks on the connector and battery-chamber/memory card slot covers while the camera is immersed.
- Do not leave the product immersed for more than 60 minutes at a time or expose it to depths greater than 15 m (49 ft) or to rapids, waterfalls, water flowing at full force from a tap, or other water under high pressure. Failure to observe these precautions could expose the product to pressures high enough to cause water entry.



- Do not expose the camera to water colder than 0 °C (32 °F) or warmer than 40 °C (104 °F). Do not take into hot springs or baths.
- Do not dive into the water with the camera, drop it, place it under heavy objects, or otherwise subject it to violent shocks or excessive physical pressure or force. The camera may deform and become vulnerable to leaks under excessive external pressure.
- Failure to follow correct procedures before or during use could result in irreparable damage to the product due to water entry. Should the product leak, cease use immediately, dry the camera and lens, and consult a Nikon-authorized service representative.
- The camera does not float. Be careful not to drop the camera while in or on the water.
- Condensation may form inside the lens or monitor if the product is exposed to rapid changes in temperature, such as occur when the product is taken into cold water from a hot shore location, into a warm room from a cold exterior, or the battery-chamber/memory card slot cover is opened or closed or lenses are attached or removed in a humid location. Such condensation will not cause malfunction or other damage.

Before Using the Camera Underwater

Before using the camera underwater, complete the following checklist.

- Have you removed the strap intended exclusively for use on land? We recommend that you attach a hand strap (available separately from third-party suppliers) before taking the camera into the water.*

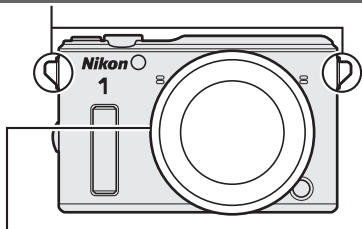

- Have you attached the special-purpose waterproof lens (□ 33)?*

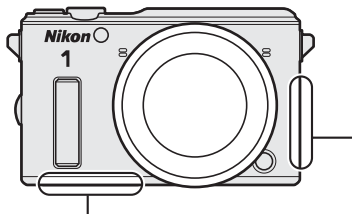

- Have you inserted the battery and memory card (32)?
- To prevent water entry and other damage, remove any sand, dust, hair, and foreign objects from under the connector and battery-chamber/memory card slot covers, and use a blower or cotton swab to remove foreign objects from inside the camera (when using a cotton swab, be sure not to leave any threads behind). If the watertight channel is cracked, deformed, or damaged, consult a Nikon-authorized service representative.

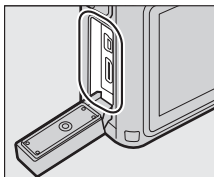
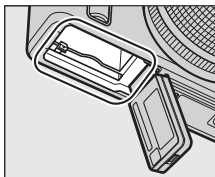

- Be sure that the connector and battery-chamber/memory card slot covers are fully closed, that the hand strap is not caught in either cover, and that the latches and security locks are in the positions shown.

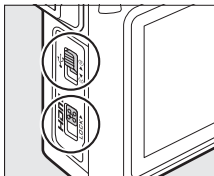
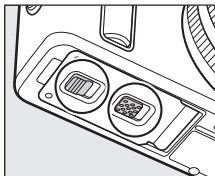

The Final Check

After going through the pre-shooting checklist on page 62 and confirming that the special-purpose waterproof lens is attached and the connector and battery-chamber/memory card slot covers are closed and secure, immerse the camera in fresh water, turn it on, and test the

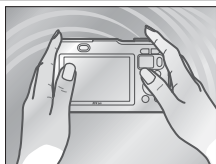

zoom ring and camera controls to ensure that they operate normally and that the camera does not leak. To prevent water entry and other damage, do not operate the lens release button or the latches or security locks on the connector and battery-chamber/memory card slot covers.

Should you notice air escaping from around the lens mount or the connector and battery-chamber/memory card slot covers, end the test and remove the camera from the water immediately (air escaping from the pressure-equalization vent and microphone and speaker covers is normal and does not indicate a malfunction). Dry the camera and lens thoroughly and check the O-ring and connector and battery-chamber/memory card slot covers are properly sealed. Consult a Nikon-authorized service representative if you find that the camera leaks in normal use.

Taking Pictures Underwater

Follow steps below to take pictures in “Underwater” mode.

1 Turn the camera on.

Press the power switch to turn the camera on.

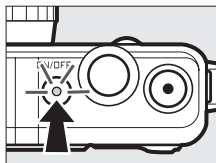

2 Select **CC** mode.

Press the MENU button to display the menus, then select **Shooting mode**, highlight **CC** (creative mode), and press **OK** (see page 27).



3 Select Underwater.

Press **▲** (**F**) to display the creative menu. Highlight **Underwater** and press **OK** to display underwater processing options.

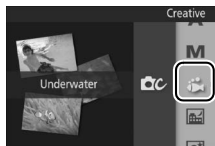

4 Choose an option.

Highlight one of the following options and press **OK** to select the highlighted option and return to the shooting display.

- **Standard**: Standard processing for balanced results when shooting along the shore or in shallow water.
- **Scuba**: Vivid colors for deeper waters.
- **Close up**: Enhanced contrast for underwater close-ups.

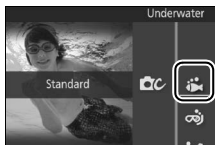

5 Take pictures.

To take photographs, press the shutter-release button halfway to focus and the rest of the way down to shoot. The shutter will be released whether or not the camera is in focus. Movies can be recorded using the movie-record button.

Shutter-release button

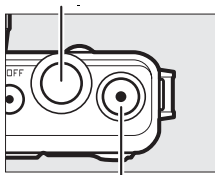

Movie-record button

Underwater Mode

The creative mode **Underwater** option automatically compensates for the blue cast in underwater lighting. Colors can be previewed in the monitor and adjusted manually or using preset options; the results apply to both photographs and movies. To adjust the blue-green balance manually, press **OK** in the shooting display and then press **▲** or **▼**. Press **OK** to exit when colors are adjusted to your satisfaction.

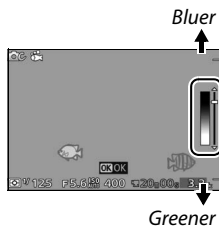

Tips and Tricks for Underwater Photography

The following features may come in handy when you are taking pictures underwater.

Auto Distortion Control

To control distortion when shooting underwater, select **On (underwater)** for **Auto distortion control** in the shooting menu (📖 99). This option is only available when a special-purpose underwater lens is attached.

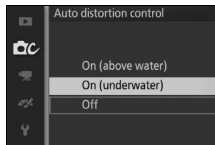

The Built-in Flash

To raise the flash for use underwater, press the flash pop-up button (📖 91). Note that manual color adjustment is not available when the flash is used with the creative mode **Underwater** option (📖 66). Water currents can push the flash part way down, causing vignetting (📖 94).

See Also

The **Underwater** white balance option can be used to correct for the blue cast in underwater lighting (📖 100).

The Depth Gauge

Using the depth gauge, you can view your depth during shooting or include the depth in the photo info recorded when a picture is taken. Set the gauge to zero before entering the water (📖 70).



■ Viewing Depth

1 Select Record location data.

In the setup menu, select **Location data**, then highlight **Record location data** and press ►.

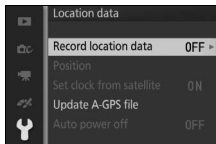

2 Select Yes.

Highlight **Yes** and press Ⓞ.

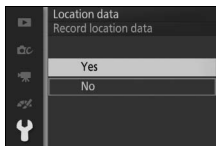

3 Select Altimeter/depth gauge.

In the setup menu, select **Altitude/depth options**, then highlight **Altimeter/depth gauge** and press ►.

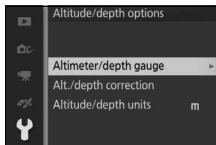

4 Select Depth gauge.

Highlight **Depth gauge** and press .

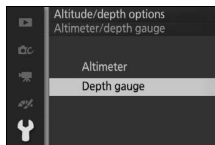

5 Exit the menus.

Press the shutter-release button half-way to exit the menus.



6 Display the depth gauge.

Press the DISP button to display the depth gauge ( 25).



The Depth Gauge

The camera depth gauge is not intended as a replacement for specialized diving gauges; the depths shown are approximations only. The display will not show depths over 20 m (65.6 ft); depths over 15 m (49 ft) are shown in red.



■ Setting the Depth Gauge to Zero

Follow the steps below to set the depth gauge to zero.

1 Select **Alt./depth correction**.

In the setup menu, select **Altitude/depth options**, then highlight **Alt./depth correction** and press ►.

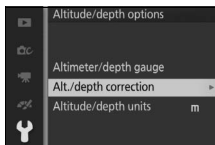

2 Select **Correct manually**.

Highlight **Correct manually** and press ►.

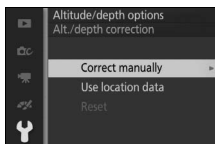

3 Set the depth gauge to zero.

Press ◀ or ▶ to highlight digits and press ▲ or ▼ to change. Press OK when changes are complete.

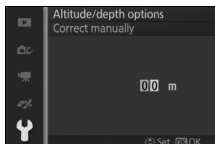

✎ See Also

For information on altitude and depth options, see page 101.

After Using the Camera Underwater

The camera and lens should be cleaned within 60 minutes of underwater use. Leaving the lens attached, immerse the camera in fresh water to remove salt and other foreign matter. Failure to observe this precaution could result in damage, discoloration, corrosion, offensive odors, or vulnerability to leaks.

✓ Before Cleaning the Camera and Lens

Clean the product indoors in areas not exposed to sand or spray and be sure to remove the front cap from the lens and any water, salt, sand, or other foreign matter from your hands or hair before proceeding. Do not open the connector or battery-chamber/memory card slot cover until all foreign matter has been washed away and the camera is dry.

1 Ready the camera.

Be sure that the special-purpose waterproof lens is attached and that connector and battery-chamber/memory card slot covers are closed with the latches and security locks in the positions shown.

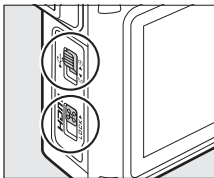
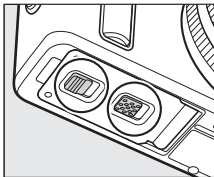

2 Immerse the camera and lens.

Leaving the lens attached, immerse the camera in a basin of fresh water for about 10 minutes. To prevent water entry and other damage, do not open the camera connector or battery-chamber/memory card slot cover while the camera is immersed.

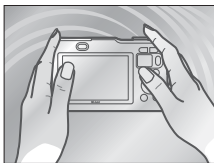

3 Clean the zoom ring and camera controls.

Being careful not to touch the lens release button or the latches or security locks on the connector and battery-chamber/memory card slot covers, press the flash pop-up button to raise the built-in flash and gently move the camera side to side, then operate the lens zoom ring and each of the remaining camera controls a few times to remove salt and other foreign objects.

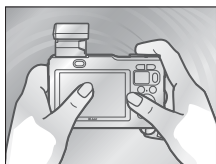

4 Wipe dry.

Dry the camera and lens barrel with a soft, dry cloth. Water, fingerprints, and other foreign matter on the front lens element should be removed immediately by gently wiping the glass with a soft, dry cloth. Do not use force.

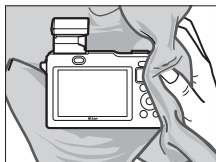

5 Leave in the shade.

Without removing the lens, place the camera on a dry cloth as shown and leave it to dry in a shady, well-ventilated area. Water will drain from the zoom ring, pressure-equalization vent, and the holes in the microphone and speaker covers.

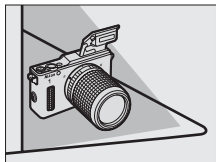

6 Clean inside the covers.

After confirming that no water or other foreign matter remains on the camera, slowly open the connector and battery-chamber/memory card slot covers and remove any water droplets, sand, or other foreign matter from the interior with a soft, dry cloth.

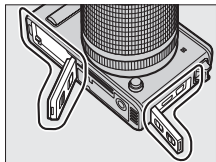

To prevent water falling into the camera when the covers are opened, hold the camera so that the covers open downwards.

7 Remove the lens.

After confirming that the lens and camera are dry, detach the lens and gently wipe the lens O-ring seal with a soft, dry cloth to remove any foreign objects. Note that there may still be water between the camera and the lens; to prevent water falling onto the dust shield or lens when the lens is detached, keep the camera flat and remove the lens slowly.

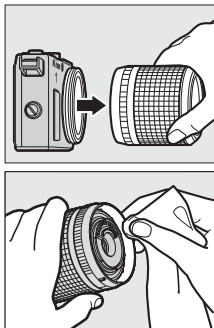

The O-Ring

The camera uses an O-ring to form a watertight seal. Improper handling of the O-ring can produce leaks. *Check the condition of the O-ring as described below whenever the camera has been used under water or whenever foreign matter is found on the O-ring when the lens is removed.*

1 Remove the O-ring.

Lightly stretch the O-ring by sliding your fingers along either side and remove it from the camera (you can also use an optional O-ring remover; □ 108). Do not apply excessive force or use your fingernails, metal objects, or edged or pointed tools.

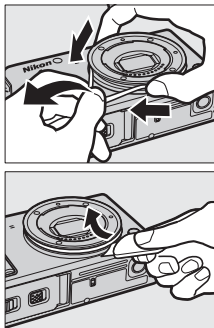

2 Wash the O-ring.

Wash the O-ring thoroughly in fresh water and dry thoroughly. Do not use benzene, thinner, alcohol, soap, neutral detergents, or other cleaning products, as these could damage or weaken the O-ring.

3 Inspect the O-ring.

Remove any foreign matter with a soft, dry cloth, taking care not to leave tissue or threads on the O-ring. Gently bend the O-ring to check for cracking or other damage.

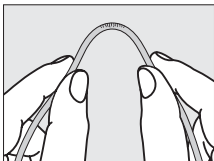

4 Inspect the O-ring guide.

Use a blower or cotton swab to remove any foreign objects from the O-ring guide. Be sure to remove any threads left behind by the swab.

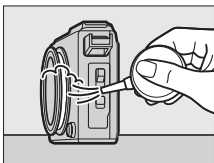

5 Grease the O-ring.

Place a bead of silicon grease in a plastic bag and use your fingers to spread the grease throughout the bag (①), then insert the O-ring and massage the bag to coat the ring (②).

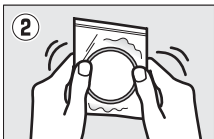

6 Re-insert the O-ring.

After making sure that O-ring and guide are free of foreign objects, place the O-ring so that it runs evenly at the same level all the way round the O-ring guide, without undue stretching and without protruding from the guide.

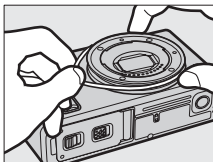

O-Rings

The O-ring requires periodic replacement. Replace the O-ring immediately if it is damaged, cracked, warped, or has lost its elasticity. O-rings should be replaced at least once a year even if the product has not been used; use only O-rings designated for use in this product. O-rings must be greased before use and whenever the surface appears dry; failure to observe this precaution could result in the O-ring cracking and water entering the camera.

Silicon Grease

Coating the O-ring with the supplied silicon grease prevents wear and ensures that the lens rotates smoothly. Use only the supplied silicon grease or optional WP-G1000 silicon grease (☞ 108); failure to observe this precaution could result in O-ring becoming stretched or otherwise deformed. Replacement O-rings and silicon grease can be purchased from a Nikon camera retailer or Nikon-authorized service representative. Do not use grease in excessive amounts or apply using paper or cloth, as this may cause dust or fibers to adhere to the O-ring, making the product vulnerable to leaks.





✓ Maintenance

Observe the following precautions when cleaning the camera and lens after underwater use.

- Never remove the lens or open the connector or battery-chamber/memory card slot cover under water. Before exchanging lenses or opening or closing the covers, wipe off water with a soft, dry cloth and be sure the product is completely dry, as otherwise water from the lens or covers may fall into the battery chamber or memory card slot or onto the battery, memory card, watertight channel, hinges, or connectors. Choose shaded locations free from spray, wind, dust, and sand, and check for water on the inside of the covers before closing them. Water on the inside of the covers could result in condensation or other damage.
- Air may escape from the pressure-equalization vent or microphone and speaker covers when the camera is immersed. This is normal and does not indicate a malfunction. Note that water in the holes of the microphone and speaker covers may interfere with sound quality; dry the covers with a soft, dry cloth, but do not insert sharp objects into the holes, as this could damage the camera or make it vulnerable to leaks.
- Do not dry the camera or lens by leaving it in direct sunlight or dry using hair dryers or other powered devices. Failure to observe this precaution could damage the camera, lens, or O-ring, resulting in leaks.
- Benzene, thinner, alcohol, soap, neutral detergents, and other cleaning products may deform the watertight channel or camera body, making the product vulnerable to leaks.
- To ensure that the product remains waterproof, have the watertight channel inspected once a year, and serviced once every 3 to 5 years, by a Nikon-authorized service representative. Fees are charged for these services.

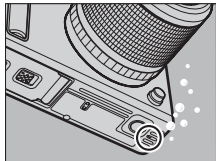



✎ Foreign Matter on the Camera and Lens

Liquid on the lens O-ring seal or inside the connector or battery-chamber/memory card slot cover should be removed immediately with a soft, dry cloth; other foreign matter should be removed with a blower, taking care to remove any small particles from the sides and corners of the watertight channels. Foreign matter on the camera body can be removed with a soft, dry cloth.

Recording and Viewing Movies

The camera can record high-definition (HD) movies with an aspect ratio of 16 : 9 and slow-motion movies with an aspect ratio of 8 : 3. Movie recording is available in the shooting modes listed below (movie recording is not available in best moment capture and Motion Snapshot modes).

Mode	Movie type	Description	
 Auto mode (□ 40)	HD (16 : 9)	The camera automatically optimizes settings for the current subject or scene.	
 Creative mode (□ 49)		Shoot movies. Regardless of the scene selected with the camera, movies are recorded in mode P; shutter speed and aperture are controlled by the camera.	
 Advanced movie mode (□ 78, 83)		Programmed auto (P)	Shutter speed and aperture are controlled by the camera.
		Shutter-priority auto (S)	You choose the shutter speed; the camera automatically adjusts aperture for optimal exposure (□ 53).
		Aperture-priority auto (A)	You choose the aperture; the camera automatically adjusts shutter speed for optimal exposure (□ 54).
Manual (M)	You choose the shutter speed and aperture (□ 55).		
Slow motion (●●)	Slow motion (8 : 3)	Record silent slow-motion movies. Movies are recorded at 400 fps and play back at about 30 fps (□ 83).	



Recording HD Movies

Record movies with sound at an aspect ratio of 16 : 9.

1 Turn the camera on.

Press the power switch to turn the camera on.

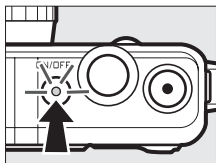

2 Frame the opening shot.

Frame the opening shot with your subject in the center of the display.

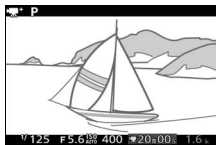

The icon

A  icon indicates that movies can not be recorded.

3 Start recording.

Press the movie-record button to begin recording. A recording indicator, the time elapsed, and the time available are displayed while recording is in progress.

Audio Recording

Be careful not to cover the microphone and note that the built-in microphone may record sounds made by the camera or lens; these noises may sound louder under water. By default, the camera focuses continuously. The **Movie sound options** item in the movie menu offers microphone sensitivity and wind noise options (📖 100).

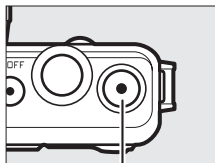

Movie-record button

*Recording indicator/
Time elapsed*



Time available

4 End recording.

Press the movie-record button again to end recording. Recording will end automatically when the maximum length is reached, the memory card is full, the lens is removed, or the camera becomes hot (📖 18).

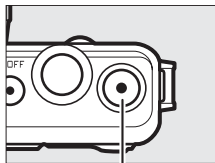

Movie-record button

Maximum Length

At default settings, HD movies can be up to 4 GB in size and 20 minutes in length; note that depending on memory card write speed, shooting may end before this length is reached (📖 113).



Taking Photographs During HD Movie Recording

Press the shutter-release button all the way down to take a photograph without interrupting HD movie recording. Photographs taken during movie recording have an aspect ratio of 3 : 2.

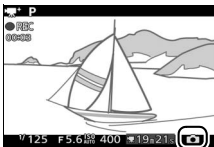

Taking Photographs During Movie Recording



Up to 20 photographs can be taken with each movie shot. Please note that photographs can not be taken with slow-motion movies.

Focus Lock

If **Single AF** is selected for **Focus mode** in the movie menu for advanced movie mode, focus will lock while the shutter-release button is pressed halfway ( 100).



Viewing Movies

Movies are indicated by a  icon in full-frame playback (44). Press  to start playback.



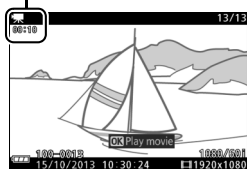



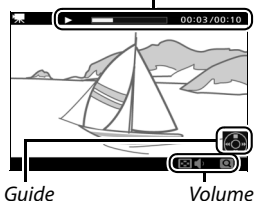



 icon/Length



Movie playback indicator/
Current position/total length



The following operations can be performed:

To	Use	Description
Pause		Pause playback.
Play		Resume playback when the movie is paused or during rewind/advance.
Advance/ rewind		Press  to rewind,  to advance. Speed increases with each press, from 2x to 4x to 8x to 16x. If playback is paused, the movie rewinds or advances one frame at a time; keep the button pressed for continuous rewind or advance.
Adjust volume		Press  to increase volume,  to decrease.
Return to full-frame playback		Press  or  to exit to full-frame playback.

Deleting Movies

To delete the current movie, press . A confirmation dialog will be displayed; press again to delete the movie and return to playback, or press to exit without deleting the movie. *Note that once deleted, movies can not be recovered.*

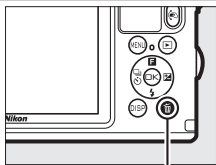

button

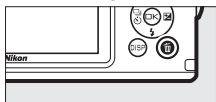

See Also

The **Edit movie** option in the playback menu can be used to trim unwanted footage from existing movies ([page 98](#)).

Use the **Movie settings** option in the movie menu to choose the frame size and rate for HD movies ([page 100](#)).

The Button

During movie playback and when playback is paused, you can advance and rewind by holding the button and tilting the camera left or right ([page 96](#)).



Recording Slow-Motion Movies

Silent slow-motion movies with an aspect ratio of 8 : 3 can be recorded by pressing **▲ (F)** in advanced movie mode and selecting **🎥+ Slow motion**. Slow-motion movies are recorded at 400 fps and play back at about 30 fps.

1 Select **🎥+** mode.

Press the MENU button to display the menus, then select **Shooting mode**, highlight **🎥+** (Advanced movie), and press **OK** (📖 27).

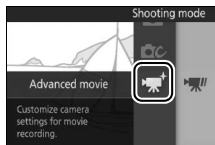

2 Select **Slow motion**.

Press **▲ (F)**, then highlight **Slow motion** and press **OK**.

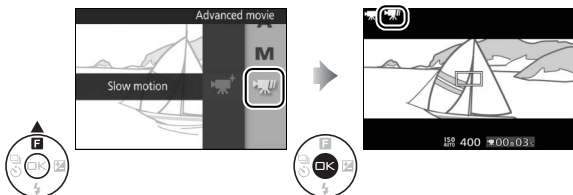

3 Frame the opening shot.

Frame the opening shot with your subject in the center of the display.

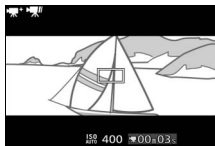

4 Focus.



Focus area

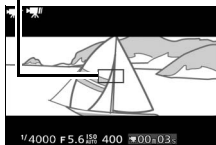

5 Start recording.

Press the movie-record button to begin recording. A recording indicator, the time elapsed, and the time available are displayed while recording is in progress. The camera focuses on the subject at the center of the display; face detection (46) is not available and focus and exposure can not be adjusted.

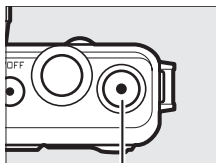

Movie-record button

*Recording indicator/
Time elapsed*

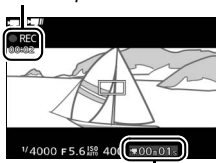

Time available

6 End recording.

Press the movie-record button again to end recording. Recording will end automatically when the maximum length is reached, the memory card is full, the lens is removed, or the camera becomes hot (📖 18).

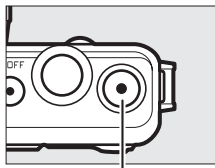

Movie-record button

Maximum Length

Up to 3 seconds of footage can be recorded; note that depending on memory card write speed, shooting may end before this length is reached (📖 113).



Recording Movies

Flicker, banding, or distortion may be visible in the display and in the final movie under fluorescent, mercury vapor, or sodium lamps or if the camera is panned horizontally or an object moves at high speed through frame (flicker and banding can be reduced in HD movies by choosing a **Flicker reduction** option that matches the frequency of the local AC power supply as described on page 101, but note that the slowest shutter speed available is $\frac{1}{100}$ s at **50 Hz**, $\frac{1}{60}$ s at **60 Hz**; flicker reduction is not available with slow-motion movies). Bright light sources may leave after-images when the camera is panned. Jagged edges, color fringing, moiré, and bright spots may also appear. When recording movies, avoid pointing the camera at the sun or other strong light sources. Failure to observe this precaution could result in damage to the camera's internal circuitry.

The Movie Crop

The movie crop is shown in the monitor.

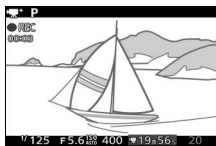

HD crop (16 : 9)

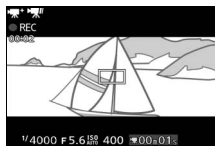

*Slow-motion movie crop
(8 : 3)*

See Also

Use the **Frame rate** option in the movie menu to choose the frame rate for slow-motion movies (100).



More on Photography

This section describes other features you can use when taking pictures.

Continuous Mode

In continuous (burst) mode, the camera takes pictures while the shutter-release button is pressed all the way down.

1 Display release mode options.

Press ◀ (📷) to display release mode options.



2 Select a frame rate.

Highlight the desired frame rate and press (OK). Frame rate is expressed in terms of the number of frames recorded per second (fps); choose from frame rates of approximately 5, 15, 30, and 60 fps (**5 fps**, **15 fps**, **30 fps**, and **60 fps**, respectively).

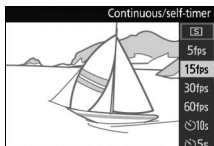

3 Compose the shot and start shooting.

The camera takes pictures while the shutter-release button is pressed all the way down.





Continuous Mode

The maximum number of shots that can be taken in a single burst varies with the release mode. At frame rates of 30 and 60 fps, the maximum number of shots that can be taken in a single burst is 20.

The built-in flash can be used when **5 fps** is selected, but only one picture will be taken each time the shutter-release button is pressed; at settings of 15, 30, and 60 fps, the built-in flash will not fire.

While photographs are being recorded to the memory card, the memory card access lamp will light. Depending on shooting conditions and memory card write speed, recording may take some time. If the battery is exhausted before all photographs are recorded, the shutter release will be disabled and the remaining images transferred to the memory card.

Continuous shooting is not available in creative modes other than **P, S, A, M**, or , , in best moment capture, advanced movie, or Motion Snapshot mode, or when live image control is used in auto mode (□ 47).

Single Frame

To take only one picture each time the shutter-release button is pressed all the way down, select  (single frame, the default option) for **Continuous/self-timer**.



Self-Timer Modes

The self-timer is used to delay shutter release until 10, 5, or 2 seconds after the shutter-release button is pressed all the way down.

1 Display release mode options.

Press ◀ (📷) to display release mode options.



2 Select the desired self-timer option.

Use the multi selector to highlight ⌚ 10 s, ⌚ 5 s, or ⌚ 2 s and press (OK).

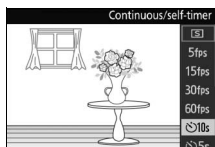

3 Mount the camera on a tripod.

Mount the camera on a tripod or place the camera on a stable, level surface.

4 Frame the photograph and shoot.

Press the shutter-release button half-way to focus, and then press the button the rest of the way down. The self-timer lamp will start to flash and a beep will begin to sound. Two seconds before the photo is taken, the lamp will stop flashing and the beeping will become more rapid.

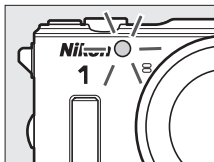

Note that the timer may not start or a photograph may not be taken if the camera is unable to focus or in other situations in which the shutter can not be released. Turning the camera off cancels the self-timer.

 **Movie Mode**

In self-timer mode, start and stop the timer by pressing the movie-record button instead of the shutter-release button.

 **Raising the Flash**

If additional lighting is required, press the flash pop-up button to raise the flash before shooting. Shooting will be interrupted if the flash is raised while the timer is counting down.

 **See Also**

For information on controlling the beeps that sound when the self-timer is used, see page 101.



The Built-in Flash

Use the built-in flash for additional lighting when the subject is poorly lit or to “fill-in” (illuminate) back-lit subjects.

1 Raise the flash.

Press the flash pop-up button to raise the flash.

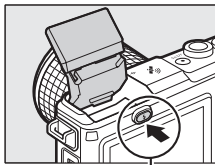

Flash pop-up button

2 Choose a flash mode (☰ 92).

Press ▼ (⚡) on the multi selector to display a list of flash modes, then use the multi selector to highlight the desired mode and press OK to select.

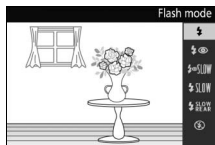





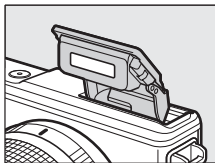









3 Take pictures.

Charging begins when the flash is raised; once charging is complete, a flash-ready indicator (⚡) will be displayed when the shutter-release button is pressed halfway.



Flash Modes

The options available vary with the shooting mode.



-  (fill flash): The flash fires with every shot.
-  (red-eye reduction): Use for portraits. The flash fires with every shot, but before it fires, the red-eye reduction lamp lights to help reduce “red-eye.” Not available in  (underwater; , ) mode.
-  SLOW (red-eye reduction + slow sync): As for “red-eye reduction”, above, except that shutter speed slows automatically to capture background lighting at night or under low light. Use when you want to include background lighting in portraits. Available only in modes **P** and **A**.
-  SLOW (fill flash + slow sync): As for “fill flash”, above, except that shutter speed slows automatically to capture background lighting at night or under low light. Use when you want to capture both subject and background. Available only in modes **P**, **A**, and  (underwater; , ) .
-  SLOW REAR (rear curtain + slow sync): As for “rear-curtain sync”, below, except that shutter speed slows automatically to capture background lighting at night or under low light. Use when you want to capture both subject and background. Available only in modes **P**, **A**, and  (underwater; , ) .
-  REAR (rear-curtain sync): The flash fires just before the shutter closes, creating a stream of light behind moving light sources as shown below at right. Available only in modes **S** and **M**.



Front-curtain sync



Rear-curtain sync

-  (off): The flash does not fire. Available only when built-in flash is raised; not available in  (night portrait) mode or when HDR is disabled in  (backlighting) mode.

✓ Raising the Flash

When using the flash, be sure it is fully raised as shown at right. Do not touch the flash during shooting.

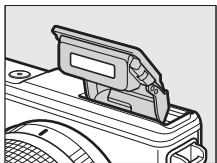



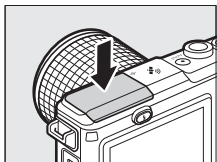

✎ Lowering the Built-in Flash

To save power when the flash is not in use, press it gently downward until the latch clicks into place. *Do not use force.* Failure to observe this precaution could result in product malfunction.



✎ Preventing the Built-in Flash from Firing

Lowering the flash prevents it firing. Except in  (night portrait) mode or when HDR is disabled in  (backlighting) mode ( 57), the flash can also be turned off by selecting a flash mode of  (off).



Using the Built-in Flash

The built-in flash can not be used with live image control (□ 47) and will not fire during continuous shooting at frame advance rates faster than 5 fps (□ 87) or when **On** is selected for **HDR** in the shooting menu (□ 57). If the flash is fired multiple times in quick succession, the flash and shutter may be temporarily disabled to protect the flash. Shooting can be resumed after a brief pause.

Objects close to the camera may be overexposed in photographs taken with the flash at high ISO sensitivities. Note that the product is not shockproof (□ 10) when the flash is raised.

To avoid vignetting, remove lens hoods. Even without a lens hood, some lenses may cause vignetting or obstruct the red-eye reduction lamp, interfering with red-eye reduction. The following illustrations show the effect of vignetting caused by shadows cast by the lens when the built-in flash is used.

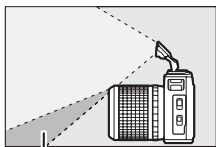

Shadow

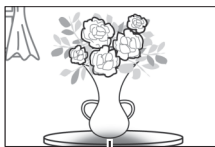

Shadow

After using the built-in flash in dusty or sandy locations, remove any foreign matter from inside the flash compartment using a blower (or, if this fails, using the technique described on page 71) before lowering the flash. Failure to observe this precaution could damage the flash.

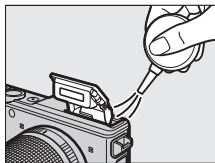

Aperture, Sensitivity, and Flash Range

Flash range varies with sensitivity (ISO equivalency) and aperture. With the standard zoom lens at maximum aperture and ISO sensitivity set to ISO 160 to 6400, the range is approximately 0.6 m–7.0 m (2 ft–23 ft) when the lens is zoomed all the way out, 0.6 m–4.2 m (2 ft–13.8 ft) at maximum zoom.

The (Action) Button

Some operations can be performed by keeping the  button pressed and tilting the camera left or right.

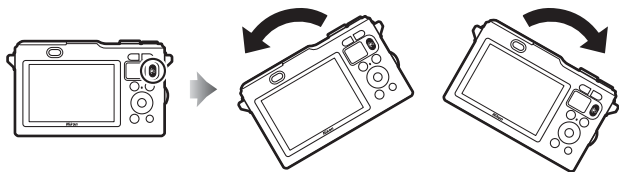

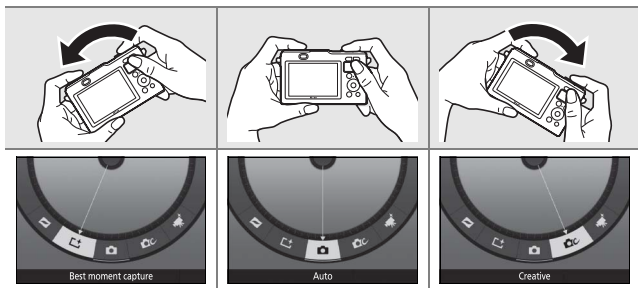

Shooting: Choosing a Shooting Mode

While the view through the lens is displayed, you can choose the shooting mode by pressing the  button, tilting the camera left or right to highlight the desired mode, and releasing the button to select the highlighted option.





To exit without changing settings, tilt the camera forward or back so that no option is highlighted when the  button is released.

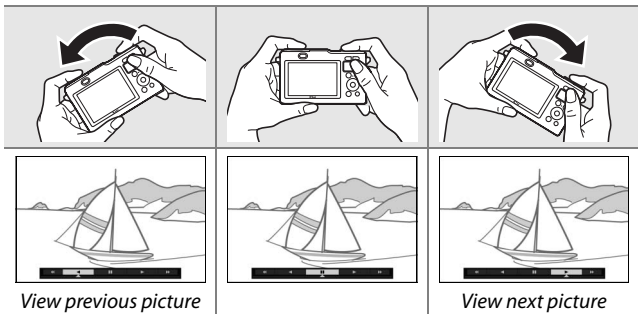

Playback: Scrolling Through Pictures

During playback, you can choose the picture displayed by pressing the  button, tilting the camera left or right, and releasing the button to display the selected picture full frame (in thumbnail playback, the camera will display and scroll through pictures full frame while the  button is pressed, and then when the button is released return to thumbnail playback with the selected picture highlighted).



Tilt the camera sharply to jump ahead or back 10 pictures. During movie playback, you can press the  button and tilt the camera to advance or rewind ( 82; speed increases the more you tilt the camera). When movie playback is paused, you can press the  button and tilt the camera to advance or rewind a frame at a time; playback pauses again when the button is released.



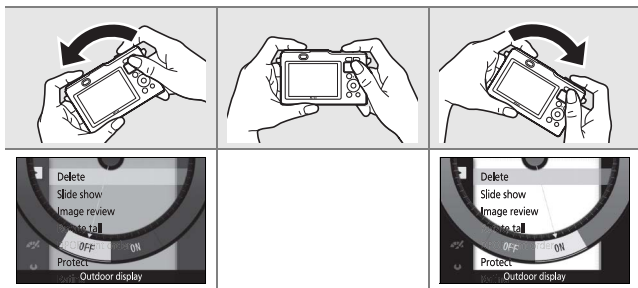

Menus: Outdoor Display

When menus are displayed, you can toggle the outdoor display on or off by pressing the  button, tilting the camera left or right, and releasing the button to select the current mode. Enabling the outdoor display makes the display easier to read outdoors or wherever ambient lighting is bright by setting the **Display brightness** and **High contrast display** options in the **Display** menu to **Hi** and **On**, respectively ( 100), but also increases the drain on the battery.



To exit without changing settings, tilt the camera forward or back so that no option is highlighted when the  button is released.

The Button

Hold the camera securely when using the  button. Controls other than the shutter-release and  buttons and the power switch can not be used while the  button is pressed. The  button can not be used to view NMS format Motion Snapshots or for playback zoom, calendar or panorama playback, or Smart Photo Selector shot selection.

Menu Options

To display the playback, shooting, movie, image processing, and setup menus, press the MENU button. Following menu options are available:

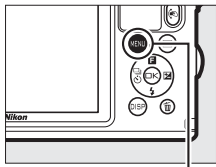

MENU button

■ Playback Menu Options

Option	Description
Delete	Delete multiple images.
Slide show	View movies and photos in a slide show.
Image review	Choose whether pictures are displayed after shooting.
Rotate tall	Rotate "tall" (portrait-orientation) pictures for display during playback.
DPOF print order	Create digital "print orders".
Protect	Protect pictures from accidental deletion.
Rating	Rate pictures.
D-Lighting	Brighten shadows in dark or back-lit photos, creating a retouched copy that is saved separately from the unmodified original.
Resize	Create small copies of selected pictures.
Crop	Create cropped copies of selected pictures.
Face-priority zoom	Choose whether ◀ and ▶ can be used during playback zoom to select faces detected with face priority.
Edit movie	Create copies of movies from which unwanted footage has been trimmed.
Change theme	Change the themes for existing Motion Snapshots.

■ Shooting Menu Options

Option	Description
Reset shooting options	Reset shooting options to default values.
Exposure mode	Choose how the camera sets shutter speed and aperture in Motion Snapshot mode.
Image quality	Choose a file format and compression ratio.
Image size	Choose a size for new photos.
Number of shots saved	Choose the number of shots selected by the Smart Photo Selector.
Movie before/after	Choose when the movie portion of Motion Snapshots is recorded.
File format	Choose a file format for new Motion Snapshots.
Metering	Choose how the camera meters exposure.
Auto distortion control	Choose whether the camera corrects barrel and pin-cushion distortion (also applies during underwater shooting with special-purpose waterproof lenses; □ 67).
Color space	Choose a color space for new pictures.
Active D-Lighting	Avoid loss of detail in highlights and shadows.
HDR	Enhance detail in highlights and shadows when photographing high-contrast scenes with Backlighting selected in creative mode.
Long exposure NR	Reduce noise in long time-exposures.
Optical VR	Adjust settings for 1 NIKKOR lenses with vibration reduction.
Electronic VR	Choose whether to use vibration reduction in Motion Snapshot mode. This feature is available even if vibration reduction is not offered by the attached 1 NIKKOR lens.
Focus mode	Choose how the camera focuses.
AF-area mode	Choose how the focus area is selected.
Face-priority	Turn face priority on or off.
Built-in AF assist	Control the built-in AF-assist illuminator.
Flash control	Choose a flash mode for the built-in flash.
Flash compensation	Control flash output.



■ Movie Menu Options

Option	Description
Reset movie options	Reset movie menu options to their default values.
Frame rate	Choose a frame rate for slow-motion movies (☐ 83).
Movie settings	Choose HD movie frame size and frame rate (☐ 78).
Metering	Choose how the camera meters exposure.
Movie sound options	Choose sound recording options.
Optical VR	Adjust settings for 1 NIKKOR lenses with vibration reduction.
Focus mode	Choose how the camera focuses.
AF-area mode	Choose how the focus area is selected.
Face-priority	Turn face priority on or off.

■ Image Processing Menu Options

Option	Description
Reset processing options	Reset image processing options to their default values.
White balance	Adjust settings for different types of lighting.
ISO sensitivity	Control the camera's sensitivity to light.
Picture Control	Choose how the camera processes pictures.
Custom Picture Control	Create custom Picture Controls.
High ISO noise reduction	Reduce noise at high ISO sensitivities.

■ Setup Menu Options

Option	Description
Reset setup options	Reset setup menu options to default values.
Format memory card	Format the memory card.
Slot empty release lock	Allow the shutter to be released when no memory card is inserted in the camera.
Display	Adjust display brightness and contrast or view or hide a framing grid.



Option	Description
Sound settings	Choose the sounds made during shooting.
Auto power off	Choose the auto power off delay.
Shutter button AE lock	Choose whether exposure locks when the shutter-release button is pressed halfway.
Control lock	Disable selected controls.
Location data	Record or view location data or use location data to set the clock, update assisted GPS files, and choose auto power off options for when the location data function is active.
Create log	Log location and depth in files saved to the memory card.
Delete log	Delete logs from the memory card.
Compass correction	Calibrate the built-in electronic compass.
Altitude/depth options	Choose whether the camera reports altitude or depth; calibrate the altimeter or depth gauge.
HDMI device control	Choose whether remote controls for HDMI-CEC devices to which the camera is connected can be used to operate the camera.
Flicker reduction	Reduce flicker or banding.
Reset file numbering	Reset file numbering.
Time zone and date	Set the camera clock.
Language	Choose a language for the camera displays.
Auto image rotation	Record camera orientation with pictures.
Wireless mobile adapter*	Enable or disable the wireless mobile adapter.
Pixel mapping	Check and optimize the camera image sensor and image processors.
Firmware version	Display the current firmware version.

* Available only when optional WU-1b wireless mobile adapter is attached.



Connecting to a Computer

Installing the Supplied Software

Install the supplied software to copy pictures to your computer for viewing and editing pictures and creating short movies. Before installing the software, confirm that your system meets the requirements on page 103.

1 Launch the installer.

Start the computer, insert the ViewNX 2/Short Movie Creator installer CD, and launch the installer. A language-selection dialog will be displayed; if the desired language is not available, click **Region Selection** to choose a different region and then choose the desired language (region selection is not available in the European release).

2 Start the installer.

Click **Install** and follow the on-screen instructions.

3 Exit the installer.

Click **Yes** (Windows) or **OK** (Mac OS) when installation is complete. The following software is installed:

- ViewNX 2
- Short Movie Creator

4 Remove the installer CD from the CD-ROM drive.

Supplied Software

Be sure to update to the latest versions of the supplied software. Nikon Message Center 2 will periodically check for updates while the computer is connected to the Internet.



System Requirements

The system requirements for ViewNX 2 are:

Windows	
CPU	<ul style="list-style-type: none">• Photos: Intel Celeron, Pentium 4, Core Series; 1.6 GHz or better• Movies (playback): Pentium D 3.0 GHz or better; Intel Core i5 or better recommended when viewing movies with a frame size of 1280 × 720 or more at a frame rate of 30 fps or above or movies with a frame size of 1920 × 1080 or more• Movies (editing): Intel Core i5 or better
OS	Pre-installed versions of Windows 8, Windows 7, Windows Vista, or Windows XP; note that 64-bit versions of Windows XP are not supported
Memory (RAM)	<ul style="list-style-type: none">• 32-bit Windows 8, Windows 7, or Windows Vista: 1 GB or more (2 GB or more recommended)• 64-bit Windows 8, Windows 7, or Windows Vista: 2 GB or more (4 GB or more recommended)• Windows XP: 512 MB or more (2 GB or more recommended)
Hard disk space	A minimum of 1 GB available on the startup disk (3 GB or more recommended)
Graphics	<ul style="list-style-type: none">• Resolution: 1024 × 768 pixels (XGA) or more (1280 × 1024 pixels or more recommended)• Color: 24-bit color (True Color) or more

Mac OS	
CPU	<ul style="list-style-type: none">• Photos: Intel Core or Xeon series• Movies (playback): Core Duo 2 GHz or better; Intel Core i5 or better recommended when viewing movies with a frame size of 1280 × 720 or more at a frame rate of 30 fps or above or movies with a frame size of 1920 × 1080 or more• Movies (editing): Intel Core i5 or better
OS	OS X 10.8 or 10.7; Mac OS X 10.6
Memory (RAM)	<ul style="list-style-type: none">• OS X 10.8 or 10.7: 2 GB or more (4 GB or more recommended)• Mac OS X 10.6: 1 GB or more (4 GB or more recommended)
Hard disk space	A minimum of 1 GB available on the startup disk (3 GB or more recommended)
Graphics	<ul style="list-style-type: none">• Resolution: 1024 × 768 pixels (XGA) or more (1280 × 1024 pixels or more recommended)• Color: 24-bit color (millions of colors) or more



Motion Snapshots

ViewNX 2 is required to view Motion Snapshots saved using the **File format > NMS files** option in the shooting menu (📖 99).

Supported Operating Systems

See the websites listed on page 19 for the latest information on supported operating systems.



Viewing and Editing Pictures on a Computer

Transferring Pictures

1 Choose how pictures will be copied to the computer.

Choose one of the following methods:

- **Direct USB connection:** Turn the camera off and ensure that the memory card is inserted in the camera. Unlock (1), unlatch (2), and open (3) the connector cover and then connect the camera to the computer using the supplied USB cable (do not use force or insert the connectors at an angle) and then turn the camera on.

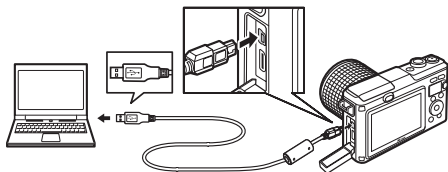
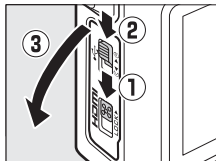

- **SD card slot:** If your computer is equipped with an SD card slot, the card can be inserted directly in the slot.
- **SD card reader:** Connect a card reader (available separately from third-party suppliers) to the computer and insert the memory card.



2 Start the Nikon Transfer 2 component of ViewNX 2.

If a message is displayed prompting you to choose a program, select Nikon Transfer 2.

Windows 7

If the following dialog is displayed, select Nikon Transfer 2 as described below.

- 1 Under **Import pictures and videos**, click **Change program**. A program selection dialog will be displayed; select **Import File using Nikon Transfer 2** and click **OK**.

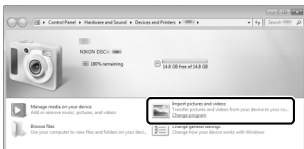

- 2 Double-click **Import file**.

3 Click Start Transfer.

At default settings, all the pictures on the memory card will be copied to the computer.



Click **Start Transfer**

4 Terminate the connection.

If the camera is connected to the computer, turn the camera off and disconnect the USB cable. If you are using a card reader or card slot, choose the appropriate option in the computer operating system to eject the removable disk corresponding to the memory card and then remove the card from the card reader or card slot.

Viewing Pictures

Pictures are displayed in ViewNX 2 when transfer is complete.

Starting ViewNX 2 Manually

- **Windows:** Double-click the ViewNX 2 shortcut on the desktop.
- **Mac OS:** Click the ViewNX 2 icon in the Dock.

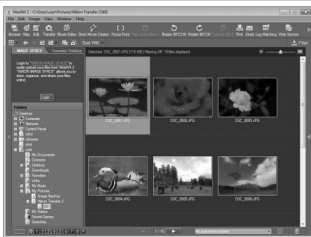

Retouching Photographs

To crop pictures and perform such tasks as adjusting sharpness and tone levels, click the **Edit** button in the toolbar.



Printing Pictures

Click the **Print** button in the toolbar. A dialog will be displayed, allowing you to print pictures on a printer connected to the computer.

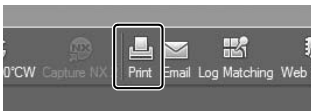

For More Information

Consult online help for more information on using ViewNX 2.

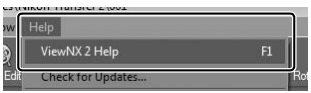

Technical Notes

Read this chapter for information on compatible accessories, cleaning and storing the camera, and what to do if an error message is displayed or you encounter problems using the camera.

Optional Accessories

At the time of writing, the following accessories were available for your camera.

Lenses	<ul style="list-style-type: none">• Waterproof 1 mount lenses• 1 mount lenses: Attach the supplied O-ring protector when using non-waterproof 1 mount lenses (□ 110).
Mount adapters	Mount Adapter FT1: When using the FT1, attach the supplied O-ring protector.
O-rings	O-Ring WP-02000: O-rings help maintain a waterproof seal when a special-purpose waterproof lens is attached. Grease O-rings before first use (□ 73).
O-ring protectors	O-Ring Protector PA-N1000: Protects the O-ring when a non-waterproof 1 NIKKOR lens is attached (□ 110).
O-ring removers	O-Ring Remover WP-OR1000: Remove O-rings (□ 73).
Silicon grease	Silicon Grease WP-G1000: Ensures that special-purpose waterproof lenses rotate freely during attachment and removal.
Power sources	<ul style="list-style-type: none">• Rechargeable Li-ion Battery EN-EL20 (□ 31–32): Additional EN-EL20 batteries are available from local retailers and Nikon-authorized service representatives.• Battery Charger MH-27 (□ 31): Recharge EN-EL20 batteries.• Power Connector EP-5C, AC Adapter EH-5b: These accessories can be used to power the camera for extended periods (EH-5a and EH-5 AC adapters can also be used). An EP-5C power connector is required to connect the camera to the EH-5b, EH-5a, or EH-5.
Body caps	Body Cap BF-N2000: The body cap keeps the dust shield free of dust when a lens is not in place.

Wireless mobile adapters	Wireless Mobile Adapter WU-1b: Supports two-way communication between the camera and smart devices running the Wireless Mobile Utility app. Use the Wireless Mobile Utility to take pictures remotely or download existing pictures to the smart device.
---------------------------------	---

 **Optional Accessories**

Availability may vary with country or region. See our website or brochures for the latest information.



Non-Waterproof 1 NIKKOR Lenses

The supplied O-ring protector must be attached to the camera lens mount before the camera can be used with non-waterproof 1 NIKKOR lenses like the 1 NIKKOR VR 10–30mm f/3.5–5.6 shown in the illustrations below. Use a soft cloth to remove any foreign matter from the inside of the protector before use, and be careful to prevent dust entering the camera or adhering to the O-ring protector.

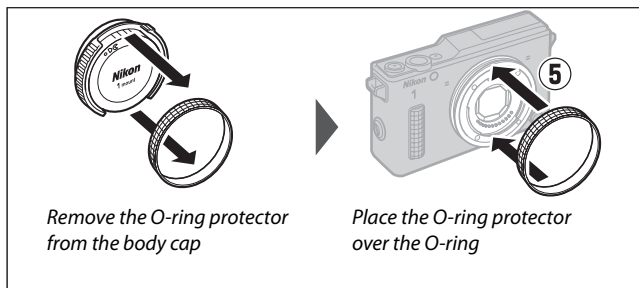
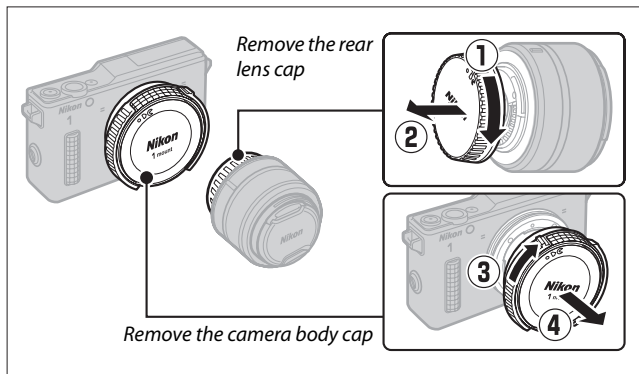

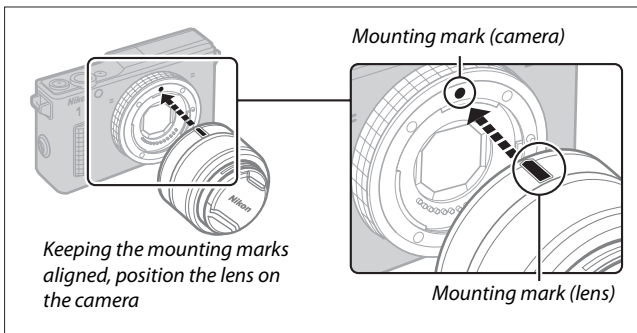

If the lens supports vibration reduction (VR), vibration reduction can be controlled from the camera (📖 99). Note that lenses with retractable lens barrel buttons can not be used when retracted. To unlock and extend the lens readying the camera for use, keep the retractable lens barrel button pressed (①) while rotating the zoom ring as shown (②).

Zoom ring

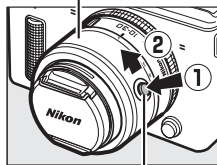

Retractable lens barrel button

Detaching Non-Waterproof Lenses

Before removing or exchanging lenses, turn the camera off. To remove the lens, press and hold the lens release button (1) while turning the lens as shown (2). After removing the O-ring protector from the camera, clean any foreign matter from the O-ring and replace the lens caps and camera body cap, and then clean the O-ring protector with a soft cloth and place the protector on the front of the body cap.

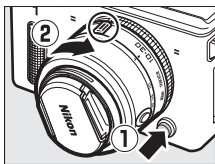

Lenses with Retractable Lens Barrel Buttons

The camera will turn on automatically when the retractable lens barrel lock is released; in addition, if the view through the lens is displayed or the monitor is off, the camera will turn off when the lens barrel is locked (in the case of 1 NIKKOR VR 10–30mm f/3.5–5.6 and 1 NIKKOR VR 30–110mm f/3.8–5.6 lenses, firmware version 1.10 or later is required if locking the lens barrel is to turn the camera off when the monitor is off; for information on updating lens firmware, visit the Nikon website for your area).

The lens can be retracted and the zoom ring locked by pressing the retractable lens barrel button and rotating the ring in the opposite direction. Be careful not to press the retractable lens barrel button while attaching or removing the lens.



Approved Memory Cards

The following cards have been tested and approved for use in the camera. Cards with class 6 or faster write speeds are recommended for movie recording. Recording may end unexpectedly when cards with slower write speeds are used.

	SD cards	SDHC cards ²	SDXC cards ³
SanDisk	2 GB ¹	4 GB, 8 GB, 16 GB, 32 GB	64 GB
Toshiba			
Panasonic			48 GB, 64 GB
Lexar Media	—	4 GB, 8 GB, 16 GB	—
Platinum II		4 GB, 8 GB, 16 GB, 32 GB	
Professional		4 GB, 8 GB, 16 GB	
Full-HD Video		4 GB, 8 GB, 16 GB	

- 1 Check that any card readers or other devices with which the card will be used support 2 GB cards.
- 2 Check that any card readers or other devices with which the card will be used are SDHC-compliant. The camera supports UHS-1.
- 3 Check that any card readers or other devices with which the card will be used are SDXC-compliant.  The camera supports UHS-1.

Other cards have not been tested. For more details on the above cards, please contact the manufacturer.



Storage and Cleaning

Underwater Use

For information on cleaning the camera after use under water or on the seashore, see page 71.

Storage

If the camera will not be used for an extended period, remove the battery and store it in a cool, dry area with the terminal cover in place. To prevent mold or mildew, store the camera in a dry, well-ventilated area. Do not store your camera with naphtha or camphor moth balls or in locations that:

- are poorly ventilated or subject to humidities of over 60%
- are next to equipment that produces strong electromagnetic fields, such as televisions or radios
- are exposed to temperatures above +50 °C (122 °F) or below -10 °C (14 °F)

Cleaning

Camera body	Use a blower to remove dust and lint, then wipe gently with a soft, dry cloth. After using the camera at the beach or seaside, wipe off sand or salt with a cloth lightly dampened in distilled water and dry thoroughly. Important: <i>Dust or other foreign matter inside the camera may cause damage not covered under warranty.</i>
Lens	Lenses are easily damaged. Remove dust and lint with a blower. If using an aerosol blower, keep the can vertical to prevent the discharge of liquid. To remove fingerprints and other stains, apply a small amount of lens cleaner to a soft cloth and clean with care.
Monitor	Remove dust and lint with a blower. When removing fingerprints and other stains, wipe the surface lightly with a soft cloth or chamois leather. Do not apply pressure, as this could result in damage or malfunction.
Dust shield	The dust shield is easily damaged. Remove dust and lint with a blower.

Do not use alcohol, thinner, or other volatile chemicals.

Caring for the Camera and Battery: Cautions

Before using the camera, read the warnings on pages 7–14. Read pages 61–76 before using the camera under water.

Do not drop: The product may malfunction if subjected to strong shocks or vibration. scratch or otherwise damage the shield.

Avoid sudden changes in temperature: Sudden changes in temperature, such as those that occur when entering or leaving a heated building on a cold day, can cause condensation inside the device. To prevent condensation, place the device in a carrying case or plastic bag before exposing it to sudden changes in temperature.

Keep away from strong magnetic fields: Do not use or store this device in the vicinity of equipment that generates strong electromagnetic radiation or magnetic fields. Strong static charges or the magnetic fields produced by equipment such as radio transmitters could interfere with the display, damage data stored on the memory card, or affect the product's internal circuitry.

Keep the lens mount covered: Be sure to attach the body cap if the camera is without a lens.

Do not touch the dust shield: The dust shield covering the image sensor is easily damaged. Under no circumstances should you exert pressure on the shield or poke it with cleaning tools. These actions could

Turn the product off before removing or disconnecting the power source: Do not unplug the product or remove the battery while the product is on or while images are being recorded or deleted. Forcibly cutting power in these circumstances could result in loss of data or in damage to product memory or internal circuitry. To prevent an accidental interruption of power, avoid carrying the product from one location to another while the AC adapter is connected.

Cleaning: When cleaning the camera body, use a blower to gently remove dust and lint, then wipe gently with a soft, dry cloth. After using the camera at the beach or seaside, wipe off any sand or salt using a cloth lightly dampened in pure water and then dry the camera thoroughly.

Lenses are easily damaged. Dust and lint should be gently removed with a blower. When using an aerosol blower, keep the can vertical to prevent discharge of liquid. To remove fingerprints and other stains from the lens, apply a small amount of lens cleaner to a clean, soft cloth and wipe the lens carefully.



Storage: To prevent mold or mildew, store the camera in a cool, dry, well-ventilated area. If you are using an AC adapter, unplug the adapter to prevent fire. If the product will not be used for an extended period, remove the battery to prevent leakage and store the camera in a plastic bag containing a desiccant. Do not, however, store the camera case in a plastic bag, as this may cause the material to deteriorate. Note that desiccant gradually loses its capacity to absorb moisture and should be replaced at regular intervals.

To prevent mold or mildew, take the camera out of storage at least once a month. Turn the camera on and release the shutter a few times before putting it away.

Store the battery in a cool, dry place. Replace the terminal cover before putting the battery away.

Notes on the monitor: The monitor is constructed with extremely high precision; at least 99.99% of pixels are effective, with no more than 0.01% being missing or defective. Hence while these displays may contain pixels that are always lit (white, red, blue, or green) or always off (black), this is not a malfunction and has no effect on images recorded with the device.

Images in the monitor may be difficult to see in a bright light.

Do not apply pressure to the display, as this could cause damage or malfunction. Dust or lint on the display can be removed with a blower. Stains can be removed by wiping lightly with a soft cloth or chamois leather. Should the monitor break, care should be taken to avoid injury from broken glass and to prevent liquid crystal from the display touching the skin or entering the eyes and mouth.

Do not leave the lens pointed at the sun: Do not leave the lens pointed at the sun or other strong light source for an extended period. Intense light may cause the image sensor to deteriorate or produce a white blur effect in photographs.

Moiré: Moiré is an interference pattern created by the interaction of an image containing a regular, repeating grid, such as the pattern of weave in cloth or windows in a building, with the camera image sensor grid. In some cases, it may appear in the form of lines. If you notice moiré in your photographs, try changing the distance to the subject, zooming in and out, or changing the angle between the subject and the camera.

Lines: Noise in the form of lines may in rare cases appear in pictures of extremely bright or backlit subjects.



- Batteries:** Batteries may leak or explode if improperly handled. Observe the following precautions when handling batteries:
- Use only batteries approved for use in this equipment.
 - Do not expose the battery to flame or excessive heat.
 - Keep the battery terminals clean.
 - Turn the product off before replacing the battery.
 - Remove the battery from the camera or charger when not in use and replace the terminal cover. These devices draw minute amounts of charge even when off and could draw the battery down to the point that it will no longer function. If the battery will not be used for some time, insert it in the camera and run it flat before removing it and storing it in a location with an ambient temperature of 15 °C to 25 °C (59 °F to 77 °F; avoid hot or extremely cold locations). Repeat this process at least once every six months.
 - Turning the camera on and off repeatedly when the battery is fully discharged will shorten battery life. Batteries that have been fully discharged must be charged before use.
 - The internal temperature of the battery may rise while the battery is in use. Attempting to charge the battery while the internal temperature is elevated will impair battery performance, and the battery may not charge or charge only partially. Wait for the battery to cool before charging.
 - Continuing to charge the battery after it is fully charged can impair battery performance.
 - A marked drop in the time a fully charged battery retains its charge when used at room temperature indicates that it requires replacement. Purchase a new EN-EL20 battery.
 - Charge the battery before use. When taking photographs on important occasions, ready a spare EN-EL20 battery and keep it fully charged. Depending on your location, it may be difficult to purchase replacement batteries on short notice. Note that on cold days, the capacity of batteries tends to decrease. Be sure the battery is fully charged before taking photographs outside in cold weather. Keep a spare battery in a warm place and exchange the two as necessary. Once warmed, a cold battery may recover some of its charge.
 - Used batteries are a valuable resource; recycle in accord with local regulations.



- Do not use the battery at ambient temperatures below 0°C (32°F) or above 40°C (104°F); failure to observe this precaution could damage the battery or impair its performance. Capacity may be reduced and charging times may increase at battery temperatures from 0°C (32°F) to 10°C (50°F) and from 45°C (113°F) to 60°C (140°F); the battery will not charge if its temperature is below 0°C (32°F) or above 60°C (140°F).

The battery charger: Charge the battery at ambient temperatures between 5°C (41°F) and 35°C (95°F). If the **CHARGE** lamp flashes quickly during charging, cease use immediately and take battery and charger to your retailer or a Nikon-authorized service representative.

Do not move the charger or touch the battery during charging. Failure to observe this precaution could in very rare instances result in the charger showing that charging is complete when the battery is only partially charged. Remove and reinsert the battery to begin charging again.

Use the charger with compatible batteries only. Unplug when not in use.

Memory Cards:

- The camera stores pictures on SD, SDHC, and SDXC memory cards (available separately).
- Do not remove memory cards from the camera, turn the camera off, or remove or disconnect the power source during formatting or while data are being recorded, deleted, or copied to a computer. Failure to observe these precautions could result in loss of data or in damage to the camera or card.
- Do not touch the card terminals with your fingers or metal objects.
- Do not bend, drop, or subject to strong physical shocks.
- Do not apply force to the card casing. Failure to observe this precaution could damage the card.
- Do not expose to water, heat, high levels of humidity, or direct sunlight.
- Do not format memory cards in a computer.

Servicing the Camera and Accessories

The camera is a precision device and requires regular servicing. Nikon recommends that the camera be inspected by the original retailer or Nikon-authorized service representative once a year, and that it be serviced once every three to five years (note that fees apply to these services). Frequent inspection and servicing are particularly recommended if the camera is used professionally. Any accessories regularly used with the camera, such as lenses, should be included when the camera is inspected or serviced.

Troubleshooting

If the camera fails to function as expected, check this list of common problems before consulting your retailer or Nikon representative.

Battery/Display

The camera is on but does not respond:

- Controls are locked (☐ 101).
- The camera is busy. Wait for recording or any other processing to end. If the problem persists, turn the camera off. If the camera still does not respond, remove and replace the battery or disconnect and reconnect the AC adapter, but note that this will delete any data not yet saved. Data already saved to the memory card are unaffected.

The display is off:

- The camera is off (☐ 36) or the battery is exhausted (☐ 24, 31).
- The display has turned off automatically to save power. The display can be reactivated by pressing the shutter-release button.
- The camera is connected to a computer (☐ 105) or television.

The camera turns off without warning:

- The battery is low (☐ 24, 31).
- The display has turned off automatically to save power (☐ 46). The display can be reactivated by pressing the shutter-release button.
- The camera's internal temperature is high (☐ 18, 122). Wait for the camera to cool before turning it on again.

Indicators are not displayed: Press the DISP button (☐ 25).

Shooting (All Modes)

The camera takes time to turn on: Delete files or format the memory card.

The shutter-release is disabled:

- The battery is exhausted (☐ 24, 31).
- The memory card is locked or full.
- The flash is charging (☐ 91).
- The camera is not in focus (☐ 42).
- You are currently filming a slow-motion movie (☐ 80).

Only one picture is taken each time the shutter-release button is pressed in continuous release mode: 5 fps is selected for **Continuous/self-timer** and the built-in flash is raised.

Smudges appear in photographs: Clean the front and rear lens elements or the dust shield (☐ 114).



Flicker or banding appears in movies or in the display: Choose a **Flicker reduction** setting that matches the local AC power supply (☐ 101).

No flash: See page 94. The flash will not fire when off (☐ 92) or when lowered.

Menu items are unavailable: Some options are only available in particular shooting or exposure modes or when wireless mobile adapter is attached.

Movies

Cannot record movies: The movie-record button can not be used to record movies in best moment capture or Motion Snapshot mode.

No sound is recorded for movies:

- **Microphone off** is selected for **Movie sound options > Microphone** (☐ 100).
- Live audio is not recorded with slow-motion movies (☐ 83) or Motion Snapshots.

Playback

“Tall” (portrait) orientation photos are displayed in “wide” (landscape) orientation:

- Select **On** for **Rotate tall** (☐ 98).
- The photos were taken with **Auto image rotation** off (☐ 101).
- Camera was pointed up or down when the photo was taken.
- Photo is displayed in image review.

Cannot hear movie sound:

- Press the **Q** button to raise the volume (☐ 81). If the camera is connected to a television, use the controls for the TV to adjust the volume.
- Live audio is not recorded with slow-motion movies (☐ 83) or Motion Snapshots.

Cannot delete images:

- Remove protection from the files before deletion.
- The memory card is locked.

Miscellaneous

The date of recording is not correct: Set the camera clock.

Menu items are unavailable: Some options are only available at particular settings or when a memory card is inserted.



Error Messages

This section lists the error messages that appear in the display.

Message	Solution
(Shutter-speed or aperture display flashes)	If the subject is too bright, lower ISO sensitivity or choose a faster shutter speed or smaller aperture (higher f-number). If the subject is too dark, raise ISO sensitivity, use the flash, or choose a slower shutter speed or larger aperture (lower f-number).
Keeping the zoom ring button pressed, rotate the zoom ring to extend the lens.	A lens with a retractable lens barrel button is attached with the lens barrel retracted. Keeping the retractable lens barrel button pressed, rotate the zoom ring to extend the lens.
Check lens. Pictures can only be taken when a lens is attached.	Attach a lens.
The clock has been reset.	Set the camera clock.
No memory card.	Turn the camera off and confirm that the card is correctly inserted.
This memory card is not formatted. Format the memory card?	Select Yes to format the card, or turn the camera off and insert another memory card.
Memory card is locked (write protected).	Turn the camera off and slide the card write-protect switch to the "write" position.
Memory card is full.	<ul style="list-style-type: none">• You may be able to record additional images if you reduce image quality or size.• Delete unwanted images.• Insert another memory card.



Message	Solution
This memory card cannot be used. Card may be damaged; insert a different card.	<ul style="list-style-type: none"> • Use an approved card. • Format the card. If the problem persists, the card may be damaged. Contact a Nikon-authorized service representative. • Insert a new memory card.
Cannot create additional folders on memory card.	If the current folder is numbered 999 and contains either 999 photographs or a photograph numbered 9999, the shutter-release button will be disabled and no further photographs can be taken. Choose Yes for Reset file numbering and then either format the current memory card or insert a new memory card.
The movie-record button cannot be used in this mode.	The movie-record button can not be used in best moment capture or Motion Snapshot modes.
Photographs cannot be recorded in this mode.	The shutter-release button can not be used to take photographs while a slow-motion movie is being recorded.
The camera's internal temperature is high. The camera will now turn off.	Wait for the camera to cool.
Memory card contains no images.	To view pictures, insert a memory card containing images.
Cannot display this file.	The file has been created or modified on a computer or different make of camera, or is corrupt.



Specifications

Nikon 1 AW1 Digital Camera

Type	
Type	Digital camera with support for interchangeable lenses
Lens mount	Nikon waterproof 1 mount
Effective angle of view	Approx. 2.7× lens focal length (35 mm format equivalent)
Effective pixels	
Effective pixels	14.2 million
Image sensor	
Image sensor	13.2 mm × 8.8 mm CMOS sensor (Nikon CX format)
Storage	
Image size (pixels)	Still images (auto, best moment capture, and all creative modes other than Easy panorama; aspect ratio 3 : 2)
	• 4608 × 3072
	• 2304 × 1536
	• 3456 × 2304
	Still images (Normal panorama, camera panned horizontally; aspect ratio 120 : 23)
	• 4800 × 920
	Still images (Normal panorama, camera panned vertically; aspect ratio 8 : 25)
	• 1536 × 4800
	Still images (Wide panorama, camera panned horizontally; aspect ratio 240 : 23)
	• 9600 × 920
	Still images (Wide panorama, camera panned vertically; aspect ratio 4 : 25)
	• 1536 × 9600
Still images (taken during movie recording, aspect ratio 3 : 2)	
• 4608 × 3072 (1080/60i, 1080/30p)	
• 1280 × 856 (720/60p, 720/30p)	
Still images (Motion Snapshots; aspect ratio 16 : 9)	
• 4608 × 2592	



File format	<ul style="list-style-type: none"> • NEF (RAW): 12-bit, compressed • JPEG: JPEG-Baseline compliant with fine (approx. 1:4), normal (approx. 1:8), or basic (approx. 1:16) compression • NEF (RAW) + JPEG: Single photograph recorded in both NEF (RAW) and JPEG formats
Picture Control system	Standard, Neutral, Vivid, Monochrome, Portrait, Landscape; selected Picture Control can be modified; storage for custom Picture Controls
Media	SD (Secure Digital), SDHC, and SDXC memory cards
File system	DCF (Design Rule for Camera File System) 2.0, DPOF (Digital Print Order Format), Exif (Exchangeable Image File Format for Digital Still Cameras) 2.3, PictBridge

Shooting modes	auto; creative, with a choice of the following options: P , S , A , M , (∞,), night landscape, night portrait, backlighting, easy panorama, soft, miniature effect, and selective color; best moment capture (slow view and Smart Photo Selector), advanced movie (HD— P , S , A , M only—and slow motion), Motion Snapshot
-----------------------	---

Shutter	
Type	Electronic shutter
Speed	1/16,000–30 s in steps of 1/3 EV; Bulb Note: Bulb ends automatically after approximately 2 minutes
Flash sync speed	Synchronizes with shutter at X=1/60 s or slower

Release	
Mode	<ul style="list-style-type: none"> • Single frame, continuous • Self-timer
Frame advance rate	Approx. 5, 15, 30, or 60 fps
Self-timer	2 s, 5 s, 10 s

Exposure	
Metering	TTL metering using image sensor
Metering method	<ul style="list-style-type: none"> • Matrix • Center-weighted: Meters 4.5 mm circle in center of frame • Spot: Meters 2 mm circle centered on selected focus area
Mode	P programmed auto with flexible program; S shutter-priority auto; A aperture-priority auto; M manual;  scene auto selector
Exposure compensation	-3 – +3 EV in increments of 1/3 EV
Exposure lock	Luminosity locked at metered value when shutter-release button is pressed halfway
ISO sensitivity (Recommended Exposure Index)	ISO 160–6400 in steps of 1 EV; auto ISO sensitivity control (ISO 160–6400, 160–3200, 160–800) available (user controlled when P , S , A , M , or underwater is selected in creative mode)
Active D-Lighting	On, off
Focus	
Autofocus	Hybrid autofocus (phase-detection/contrast-detect AF); AF-assist illuminator
Lens servo	<ul style="list-style-type: none"> • Autofocus (AF): Single AF (AF-S); continuous AF (AF-C); auto AF-S/AF-C selection (AF-A); full-time AF (AF-F) • Manual focus (MF)
AF-area mode	Single-point, single-point (center), auto-area, subject tracking
Focus area	<ul style="list-style-type: none"> • Single-point AF: 135 focus areas; the center 73 areas support phase-detection AF • Auto-area AF: 41 focus areas
Focus lock	Focus can be locked by pressing shutter-release button halfway (single AF)
Face priority	On, off



Flash	
Built-in flash	Manual pop-up
Guide Number (GN)	Approx. 5/16 (m/ft, ISO 100, 20 °C/68 °F; at ISO 160, Guide Number is approx. 6.3/20.7)
Control	i-TTL flash control using image sensor
Mode	Fill flash, red-eye reduction, fill flash + slow sync, red-eye reduction + slow sync, rear curtain + slow sync, rear-curtain sync, off
Flash compensation	-3–+1 EV in increments of 1/3 EV
Flash-ready indicator	Lights when built-in flash unit is fully charged
White balance	
	Auto, underwater, incandescent, fluorescent, direct sunlight, flash, cloudy, shade, preset manual, all except preset manual with fine tuning
Movie	
Metering	TTL metering using image sensor
Metering method	<ul style="list-style-type: none"> • Matrix • Center-weighted: Meters 4.5 mm circle in center of frame • Spot: Meters 2 mm circle centered on selected focus area
Frame size (pixels)/ recording rate	HD movies (aspect ratio 16 : 9)
	<ul style="list-style-type: none"> • 1920 × 1080/60i (59.94 fields/s*) • 1920 × 1080/30p (29.97 fps) • 1280 × 720/60p (59.94 fps) • 1280 × 720/30p (29.97 fps)
	Slow-motion movies (aspect ratio 8 : 3)
	<ul style="list-style-type: none"> • 640 × 240/400 fps (plays at 30p/29.97 fps) • 320 × 120/1200 fps (plays at 30p/29.97 fps)
	Motion Snapshot (aspect ratio 16 : 9)
	1920 × 1080/60p (59.94 fps) (plays at 24p/23.976 fps)
File format	MOV
Video compression	H.264/MPEG-4 Advanced Video Coding
Audio recording format	AAC
Audio recording device	Built-in stereo microphone; sensitivity adjustable

* Sensor output is about 60 fps.

Monitor	7.5 cm (3-in.), approx. 921k-dot, TFT LCD with brightness adjustment
Playback	Full-frame and thumbnail (4, 9, or 72 images or calendar) playback with playback zoom, movie and panorama playback, slide show, histogram display, auto image rotation, and rating option
Interface	
USB	Hi-Speed USB
HDMI output	Type C mini-pin HDMI connector
Electronic compass/location data/altimeter/depth gauge	
Electronic compass	16 headings (with 3-axis accelerometer attitude correction and automatic offset adjustment)
Location data	<ul style="list-style-type: none"> • Receiving frequency: 1575.4200 MHz (GPS)/1598.0625–1605.3750 MHz (GLONASS) • Geodesics: WGS84
Altimeter	Operating range approximately –500–+4500 m (–1640–+14,760 ft)
Depth gauge	Operating range approximately 0–20 m (0–65.6 ft)
Supported languages	Arabic, Bengali, Bulgarian, Chinese (Simplified and Traditional), Czech, Danish, Dutch, English, Finnish, French, German, Greek, Hindi, Hungarian, Indonesian, Italian, Japanese, Korean, Marathi, Norwegian, Persian, Polish, Portuguese (European and Brazilian), Romanian, Russian, Serbian, Spanish, Swedish, Tamil, Telugu, Thai, Turkish, Ukrainian, Vietnamese
Power source	
Battery	One rechargeable Li-ion EN-EL20 battery
AC adapter	EH-5b AC adapter; requires EP-5C power connector (available separately)
Tripod socket	1/4-in. (ISO 1222)
Dimensions/weight	
Dimensions (W × H × D)	Approx. 113.3 × 71.5 × 37.5 mm (4.5 × 2.9 × 1.5 in.), excluding projections
Weight	Approx. 356 g (12.6 oz) with battery and memory card but without body cap or O-ring protector; approx. 313 g (11.1 oz), camera body only



Operating environment	
Temperature	-10 °C–+40 °C (+14 °F–104 °F) on land, 0 °C–+40 °C (+32 °F–104 °F) in water
Humidity	85% or less (no condensation)
Shock-, water-, and dust-proofing	
Shockproof performance ^{1,2}	Has passed in-house tests ³ to MIL-STD-810F Method 516.5: Shock standard
Waterproof performance ²	In-house tests have demonstrated JIS/IEC Class 8 (IPX8) waterproofing; can be used at depths of up to 15 m (49 ft) for up to 60 minutes
Operating depth ²	Maximum 15 m (49 ft)
Dustproof performance ²	In-house tests have demonstrated JIS/IEC Class 6 (IP6X) dust-proofing

1 Does not apply when built-in flash is raised.

2 With special-purpose waterproof lens attached.

3 Using a test method derived from MIL-STD-810F Method 516.5: Shock, the product is dropped from a height of 200 cm (6.6 ft) onto a plywood surface 5 cm (2 in.) thick. Exterior deformation and surface damage are not tested. These in-house tests do not constitute blanket guarantees of invulnerability to damage or destruction.

- Unless otherwise stated, all figures are for a camera with a fully-charged battery operating at the temperature specified by the Camera and Imaging Products Association (CIPA): 23 ±3 °C (73.4 ±5.4 °F).
- Nikon reserves the right to change the specifications of the hardware and software described in this manual at any time and without prior notice. Nikon will not be held liable for damages that may result from any mistakes that this manual may contain.

MH-27 battery charger	
Rated input	AC 100–240 V, 50–60 Hz, 0.2 A
Rated output	DC 8.4 V/0.6 A
Supported batteries	Nikon EN-EL20 rechargeable Li-ion batteries
Charging time	Approx. 2 hours at an ambient temperature of 25 °C (77 °F) when no charge remains
Operating temperature	0 °C–40 °C (+32 °F–104 °F)
Dimensions (W × H × D)	Approx. 67.0 × 28.0 × 94.0 mm (2.6 × 1.1 × 3.7 in.), excluding plug adapter
Weight	Approx. 83 g (2.9 oz), excluding plug adapter

EN-EL20 rechargeable Li-ion battery	
Type	Rechargeable lithium-ion battery
Rated capacity	7.2 V, 1020 mAh
Operating temperature	0 °C–40 °C (+32 °F–104 °F)
Dimensions (W × H × D)	Approx. 30.7 × 50.0 × 14.0 mm (1.2 × 2.0 × 0.6 in.)
Weight	Approx. 41 g (1.4 oz), excluding terminal cover
1 NIKKOR AW 11–27.5mm f/3.5–5.6 Lens	
Type	Waterproof 1 mount lens
Focal length	11–27.5 mm
Maximum aperture	f/3.5–5.6
Construction	8 elements in 6 groups (including 1 ED lens element and 1 aspherical lens element), 1 protective glass element
Angle of view	72°–32° 20'
Minimum focus distance	0.3 m (1.0 ft) from focal plane at all zoom positions
Diaphragm blades	7 (rounded diaphragm opening)
Diaphragm	Fully automatic
Aperture range	<ul style="list-style-type: none"> • 11 mm focal length: f/3.5–16 • 27.5 mm focal length: f/5.6–16
Electronic compass	Electronic compass can be used when lens is attached to camera
Filter-attachment size	40.5 mm (P=0.5 mm)
Shockproof performance *	Has passed in-house tests to MIL-STD-810F Method 516.5: Shock standard when attached to camera; exterior deformation and surface damage are not tested
Waterproof performance *	In-house tests have demonstrated JIS/IEC Class 8 (IPX8) waterproofing
Operating depth *	Maximum 15 m (49 ft), but may not be used at depths that exceed camera's maximum operating depth
Dustproof performance *	In-house tests have demonstrated JIS/IEC Class 6 (IP6X) dust-proofing
Operating temperature	–10 °C–+40 °C (+14 °F–104 °F) on land, 0 °C–+40 °C (+32 °F–104 °F) in water
Dimensions	Approx. 63 mm diameter × 56.5 mm (distance from camera lens mount flange)
Weight	Approx. 182 g (6.5 oz)

* When attached to waterproof cameras.



1 NIKKOR AW 10mm f/2.8 Lens

Type	Waterproof 1 mount lens
Focal length	10 mm
Maximum aperture	f/2.8
Construction	6 elements in 5 groups (including 2 aspherical lens elements), 1 protective glass element
Angle of view	77°
Minimum focus distance	0.2 m (0.7 ft) from focal plane
Diaphragm blades	7 (rounded diaphragm opening)
Diaphragm	Fully automatic
Aperture range	f/2.8–11
Electronic compass	Electronic compass can be used when lens is attached to camera
Filter-attachment size	40.5 mm (P=0.5 mm)
Shockproof performance *	Has passed in-house tests to MIL-STD-810F Method 516.5: Shock standard when attached to camera; exterior deformation and surface damage are not tested
Waterproof performance *	In-house tests have demonstrated JIS/IEC Class 8 (IPX8) waterproofing
Operating depth *	Maximum 20 m (65.6 ft), but may not be used at depths that exceed camera's maximum operating depth
Dustproof performance *	In-house tests have demonstrated JIS/IEC Class 6 (IP6X) dust-proofing
Operating temperature	-10 °C–+40 °C (+14 °F–104 °F) on land, 0 °C–+40 °C (+32 °F–104 °F) in water
Dimensions	Approx. 61 mm diameter × 30 mm (distance from camera lens mount flange)
Weight	Approx. 118 g (4.2 oz)

*When attached to waterproof cameras.

Specifications subject to change without notice. Nikon will not be held liable for damages that may result from any mistakes that this manual may contain.

Waterproof 1 NIKKOR Lenses
1 NIKKOR AW 11–27.5mm f/3.5–5.6

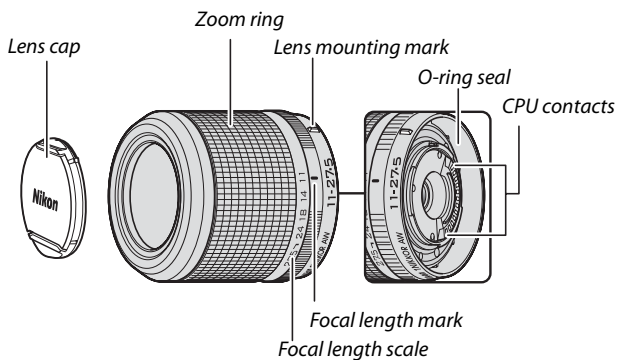

1 NIKKOR AW 10mm f/2.8

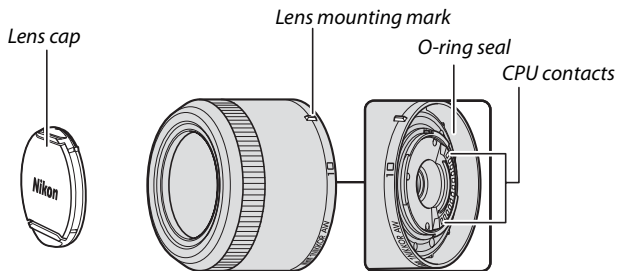

Waterproof 1 NIKKOR lenses are exclusively for Nikon 1 AW1 interchangeable lens format digital cameras. The angle of view is equivalent to a 35 mm format lens with a focal length about 2.7× longer. When attached to a waterproof camera, the water-, dust-, and shock-proof 1 NIKKOR AW 11–27.5mm f/3.5–5.6 and 1 NIKKOR AW 10mm f/2.8 lenses are compliant with the JIS/IEC Class 8 (IPX8) waterproofing standard, allowing the camera to be used at depths of up to 15 m (49 ft) for as long as 60 minutes at a time. They have also passed drop tests from a height of 2 m (6.6 ft) while attached to the camera. *These lenses are not water-, dust-, or shock-proof when not attached to the camera. The foregoing statement regarding water-, dust-, and shock-proofing is not a blanket guarantee that the product will be water- or dust-proof in all circumstances or invulnerable to damage or destruction.*

Use the zoom ring to zoom in and out.

Lens Care

- Use only with hoods, lens caps, and other accessories designated for use with this product.
- When using an optional lens hood, do not pick up or hold the lens or camera using only the hood.
- Keep the CPU contacts and O-ring seal clean and immediately remove any foreign matter with a blower.
- Contact a Nikon-authorized service representative should you notice that the O-ring seal is cracked, deformed, or otherwise damaged.
- Use a blower to remove dust and lint from the lens surfaces. To avoid scratches, do not use force when removing sand and other foreign objects.
- Never use organic solvents such as paint thinner or benzene to clean the lens.
- Attach the front and rear caps when the lens is not in use.
- If the lens will not be used for an extended period, store it in a cool, dry location to prevent mold and rust. Do not store in direct sunlight or with naphtha or camphor moth balls.
- Leaving the lens in extremely hot locations could damage or warp parts made from reinforced plastic.
- The lens features a built-in O-ring that should be replaced at least once a year by a Nikon-authorized service representative, regardless how frequently the lens is used. A fee is charged for this service.

✔ Using the Lens Under or Next to Water

- Never remove the lens under water.
- When attaching and removing the lens, carefully inspect the camera O-ring and the lens O-ring seal to be sure that they are free of threads, lint, hair, dust, sand, liquids, and other foreign matter. Be sure that the camera O-ring is not protruding, twisted, or out of position.
- Do not attach or remove the lens with wet or salt-covered hands or in areas exposed to spray, wind, sand, or dust.
- Immediately remove any water or other foreign matter from the lens and lens O-ring seal with a clean, soft, dry cloth.
- The amount of force needed to operate the zoom ring increases with depth.
- Should the product leak, cease use immediately, dry the camera and lens, and take them to a Nikon-authorized service representative.

✔ Supplied Accessories

- 40.5 mm snap-on Front Lens Cap LC-N40.5
- Rear Lens Cap LF-N2000

✔ Optional Accessories

40.5 mm screw-on Hood HN-N103 (attaches as shown below; note that the hood can not be used under water and that lens is not shockproof when hood is attached)

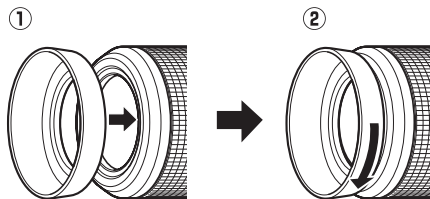

Trademark Information

Mac OS and OS X are registered trademarks of Apple Inc. in the United States and/or other countries. Microsoft, Windows, and Windows Vista are either registered trademarks, or trademarks of Microsoft Corporation in the United States and/or other countries. The PictBridge logo is a trademark. The SD, SDHC, and SDXC logos are trademarks of SD-3C, LLC. HDMI, the HDMI logo and High-Definition Multimedia Interface are trademarks or registered trademarks of HDMI Licensing LLC.

HDMI

All other trade names mentioned in this manual or the other documentation provided with your Nikon product are trademarks or registered trademarks of their respective holders.

FreeType License (FreeType2)

Portions of this software are copyright © 2013 The FreeType Project (<http://www.freetype.org>). All rights reserved.

MIT License (HarfBuzz)

Portions of this software are copyright © 2013 The HarfBuzz Project (<http://www.freedesktop.org/wiki/Software/HarfBuzz>). All rights reserved.



Battery Life

The number of shots or movie footage that can be recorded with fully-charged batteries varies with the condition of the battery, temperature, the interval between shots, and the length of time menus are displayed. Sample figures for EN-EL20 (1020 mAh) batteries are given below.

- **Still images: Approximately 250 shots**
- **Movies: Approximately 55 minutes of HD footage at 1080/60i**

Measured according to CIPA standards at 23 ± 3 °C (73.4 ± 5.4 °F) with the camera at default settings, a fully-charged battery, a 1 NIKKOR AW 11–27.5mm f/3.5–5.6 lens, and a 16 GB Toshiba SD-E016GUX UHS-I SDHC card. Value for still images obtained under the following test conditions: photographs taken at intervals of 30 s with the built-in flash fired with every other shot and the camera turned off and then on after every ten shots. Value for movies obtained under the following test conditions: a series of 20 minute movies with a file size of up to 4 GB were recorded; recording was only interrupted when temperature warning was displayed.

The following can reduce battery life:

- Keeping the shutter-release button pressed halfway
- Repeated autofocus operations
- Taking NEF (RAW) photographs
- Slow shutter speeds
- Using a wireless mobile adapter or Eye-Fi cards
- Using vibration reduction mode with VR lenses
- Using zoom with power zoom lenses
- Using the location data or track log functions
- Setting monitor brightness to **Hi**





























To ensure that you get the most from rechargeable Nikon EN-EL20 batteries:

- Keep the battery contacts clean. Soiled contacts can reduce battery performance.
- Use batteries immediately after charging. Batteries will lose their charge if left unused.



Index

Symbols

-  (Auto mode) 28, 40
-  (Creative mode) 28, 49
-  (Best moment capture mode) 28
-  (Advanced movie mode) ..29, 77
-  (Motion Snapshot mode) 27
- P** (Programmed auto) 50, 52, 77
- S** (Shutter-priority auto) 50, 53, 77
- A** (Aperture-priority auto) . 50, 54, 77
- M** (Manual) 50, 55, 77
-  (Night landscape) 50
-  (Night portrait) 51
-  (Backlighting) 51, 57
-  (Easy panorama) 51, 58
-  (Soft) 51
-  (Miniature effect) 51
-  (Selective color) 51
-  (Slow motion) 83
-  (Portrait) 46
-  (Landscape) 46
-  (Night portrait) 46
-  (Close up) 46
-  (Night landscape) 46
-  (Auto) 46
-  (flexible program) 52
- MENU (menu) button 26, 98
-  (playback) button 44
-  (delete) button 45, 82
-  (playback zoom in) button 44
-  (playback zoom out/thumbnail) button 44
- DISP (display) button 25
-  (OK) button 22, 60
-  (action) button 95
-  (feature) 29, 47, 49, 83
-  (continuous shooting/self-timer) . 87, 89
-  (flash-ready indicator) 91

A

- AC adapter 108
- Accessories 108
- Advanced movie mode 29, 77, 83
- Aperture 54, 55
- Aperture-priority auto 50, 54, 77
- Attaching the lens 33, 110
- Auto mode 28, 40
- Auto power off 46
- Automatic scene selection 46

B

- Backlighting 51, 57
- Battery 31, 32, 129
- Beep 42, 89
- Best moment capture mode 28
- Body cap 20, 21, 108
- Built-in flash 91

C

- Charging a battery 31
- Clock 37
- Close up 46
- Close up (Underwater mode) 66
- Compatible lens 108
- Computer 102
- Creative mode 49

D

- Date and time 37
- Date format 37
- Daylight saving time 37
- Delete 45, 82
- Depth gauge 68
- Dust shield 114, 115

E

- Easy panorama 51, 58
- Exposure indicator 56

F	
Face priority	46
Fill flash	92
Flash	91
Flash mode	92
Flash range	94
Flash-ready indicator	91
Flexible program	52
Focal length	41
Focal length scale	41, 131
Focal plane mark	21
Focus area	42
Format	32
Format memory card	32
Full-frame playback	44

G	
Grid display	43

H	
H.264	126
HD movies	77, 78
HDR	57

L	
Landscape	46
Language	37
Lens	33, 41, 108, 129, 130
Lens cap	33, 35
Live image control	47
Location data	14

M	
Manual	50, 55, 77
Maximum aperture	129, 130
Memory card	32, 113
Memory card access lamp	43
Microphone	79
Miniature effect	51
Monitor	24, 25
Motion Snapshot mode	27
Mount adapter	108
Movie-record button	79, 84

Movies	77
--------------	----

N	
Night landscape	46, 50
Night portrait	46, 51
Nikon Transfer 2	106
Non-waterproof lenses	110

O	
O-Ring	33, 73, 108
O-ring protector	110
Outdoor display	97

P	
Playback	44
Portrait	46
Power connector	108
Power switch	36
Press the shutter-release button all the way down	43
Press the shutter-release button halfway	42
Programmed auto	50, 52, 77

R	
Rear curtain + slow sync	92
Rear-curtain sync	92
Red-eye reduction	92
Red-eye reduction + slow sync	92
Removing the lens from the camera 35, 112	
Retractable lens barrel button ..	111, 112

S	
Scene selection	50
Scuba	66
SD card	113
Selective color	51
Self-timer	89
Shock-proofing	10, 11
Short Movie Creator	102
Shutter speed	53, 55
Shutter-priority auto	50, 53, 77



Shutter-release button	42
Silicon grease	35, 75, 108
Size	123, 126
Slow motion	83
Slow view	28
Smart Photo Selector	28
Soft	51
Speaker	22
Standard (Underwater mode)	66
Strap for use exclusively on land	31
System requirements	103

T

Temperature warnings	18
Theme	98
Time	37
Timer	89

U

Underwater (creative mode) ..	50, 66
USB	105
USB cable	105

V

ViewNX 2	102
Volume	81

W

Water- and dust-proofing	10, 11
Waterproof lenses	33, 129, 130
Wireless mobile adapter	109

Z

Zoom ring	41, 111, 131
-----------------	--------------







No reproduction in any form of this manual, in whole or in part (except for brief quotation in critical articles or reviews), may be made without written authorization from NIKON CORPORATION.

