

TCS SERIES ENGINEERING INFORMATION

The TCS-108 is a compact subwoofer designed for use in a variety of fixed installations ranging from theatres and theme parks to cafés and restaurants.

It will extend the frequency response of Turbosound TCS series enclosures, and can be added to any existing system in order to add sub-bass frequencies and increase overall power handling capability.

The TCS-108 contains a single front loaded 8" LF driver, optimally vented for extended low frequency response. The TCS-108 may be used in either a horizontal or vertical orientation to fit the space available in a particular installation. In addition, the construction of the cabinet allows two or more units to be assembled together in a variety of configurations to provide higher sound pressure level, while being flexible enough to suit the physical constraints of a given venue. TCS-108 enclosures are

shipped with additional external mounting brackets to enable the cabinets to be built up in various configurations as shown on page 4.

The cabinet is constructed from 15mm (5/8") birch plywood, and is finished in black semi-matt textured paint (other colours are optionally available).

The TCS-108 is supplied as standard with an active (for bi-amped systems) connector panel containing a Speakon NL4MP and a 4-way terminal strip for loop in / loop out connections.

A passive backplate version is available (TCS-108P) with an internal passive crossover network at 130Hz.

Recommended complementary products:

TCS-20, TCS-30, TCS-35 enclosures

LMS-D6, LMS-D4 loudspeaker management systems

**FEATURES**

- Multiple configurations
- Compact enclosure
- Extended LF response

APPLICATIONS

- Cafés and bars
- Restaurants
- Theme parks
- Theatre

DIMENSIONS (HxWxD)	274mm x 337mm x 440mm (10.8" x 13.3" x 17.3")
NET WEIGHT	11.5 kg (25.3 lbs)
COMPONENTS	1 x 8" (203mm) LF driver
FREQUENCY RESPONSE¹	43Hz - 140Hz ±4dB
POWER HANDLING	175 watts r.m.s., 350 watts program, 450 watts peak Recommended amplifier 350 watts @ 8 ohms
SENSITIVITY²	91dB, 1W @ 1m
MAXIMUM SPL	116dB continuous ³ , 122dB peak ⁴
CROSSOVER	Recommended crossover at 130Hz
NOMINAL IMPEDANCE	8 ohms
CONSTRUCTION	15mm (5/8") birch plywood; rebated, screwed and glued. Finished in black semi-matt textured paint
GRILLE	Black powder coated perforated steel
CONNECTORS	Neutrik Speakon NL4MP, wired pin1+: positive, pin1-: negative Four way terminal strip for loop in/loop out connection
FLYING HARDWARE	Internal M10 rigging points
OPTIONS	Optional colours: white, blue, raw birch plywood
SPARES AND ACCESSORIES	LS-8080 8" (203mm) LF loudspeaker RC-8080 Recone kit for LS-8080 MG-108 Perforated metal grille

Notes

¹Measured on axis

²Average over stated bandwidth

³Average over stated bandwidth

⁴Unweighted diode-clipped pink noise. Measured in a half space environment

FREQUENCY RESPONSE

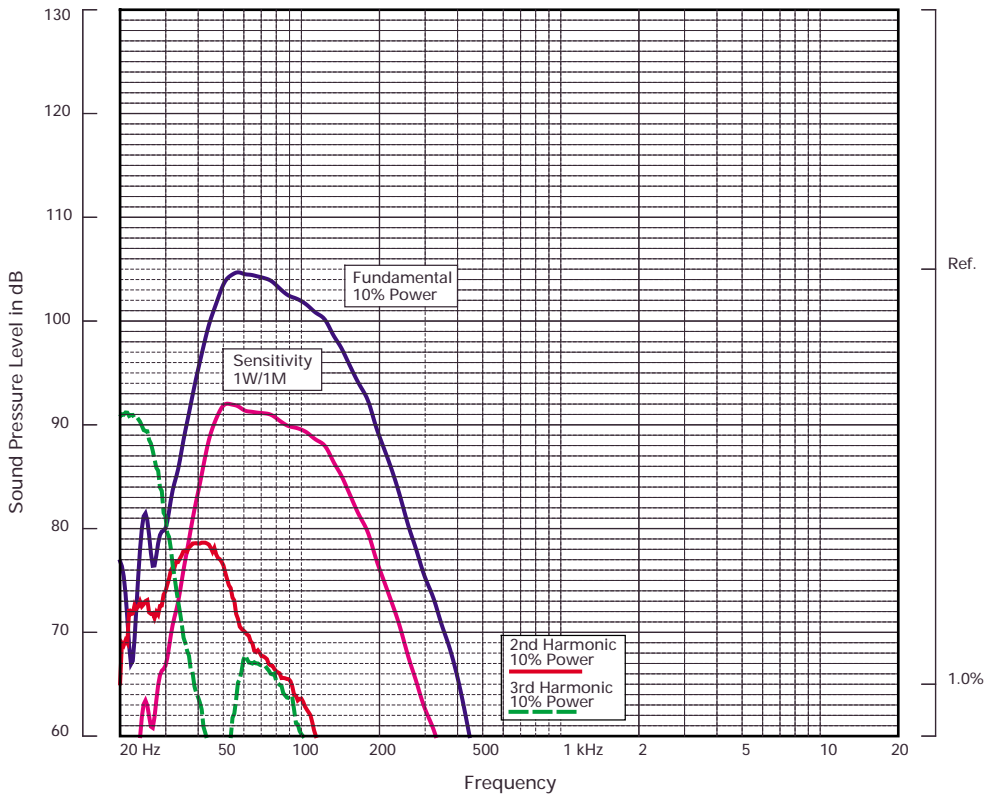

IMPEDANCE

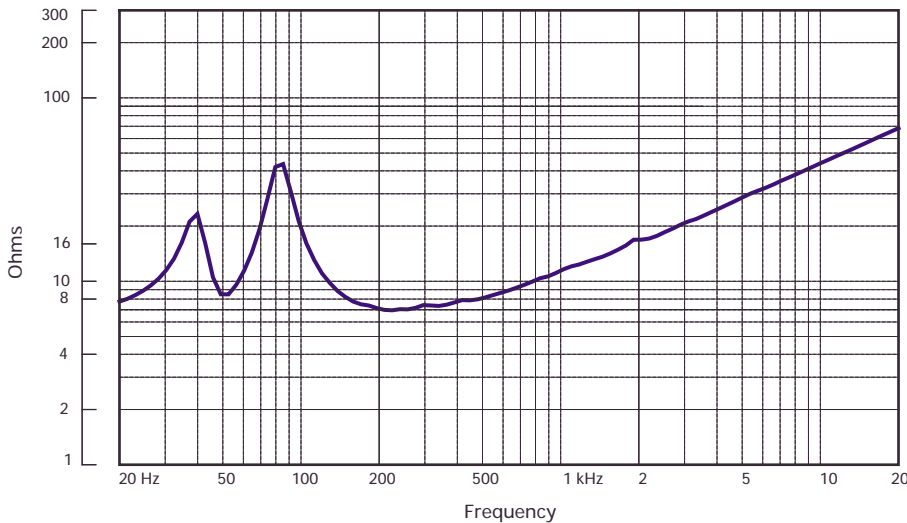

Impedance A constant current circuit was used to measure the impedance. **Frequency response** The frequency response shown was obtained by feeding a swept sine wave through the system in a half space environment. The position of the microphone was vertically on-axis at a distance of 2 metres, then scaled to represent 1 metre. **2nd & 3rd Harmonic Distortion** Distortion measurements were obtained using an Audio Precision harmonic distortion analysis system and comply with AES recommendations for enclosure measurement (AES paper ANSI S4-26-1984). **Data Conversion** All graphs were digitally generated using the APEX custom software system, designed to translate data derived from Audio Precision 'System One' test equipment into AutoCAD™. This program enables graphical information to be plotted to a high degree of accuracy.

NOTES ON MEASUREMENT CONDITIONS

**ARCHITECTURAL
& ENGINEER'S
SPECIFICATIONS**

The system shall be of the subwoofer type consisting of one 8" (203mm) low frequency loudspeaker in a vented enclosure. Performance specifications of a typical production unit shall meet or exceed the following: Frequency response, measured with swept sine wave input, shall be flat within $\pm 4\text{dB}$ from 43Hz to 140Hz. Nominal impedance shall be 8 ohms. Power handling shall be 175 watts r.m.s., 350 watts program, 450 watts peak. Sensitivity, measured with 1 watt input at 1 metre distance on axis, mean averaged over stated bandwidth, shall be 91dB. Maximum SPL (peak) measured with music program at stated amplifier input shall be 122dB. Dimensions: 274mmH x 337mmW x 440mmD (10.8"H x 13.3"W x 17.3"D). The loudspeaker system shall be the Turbosound TCS-108. No other loudspeaker shall be acceptable unless submitted data from an independent test laboratory verify that the above combined performance / size specifications are equalled or exceeded.

CONFIGURATIONS

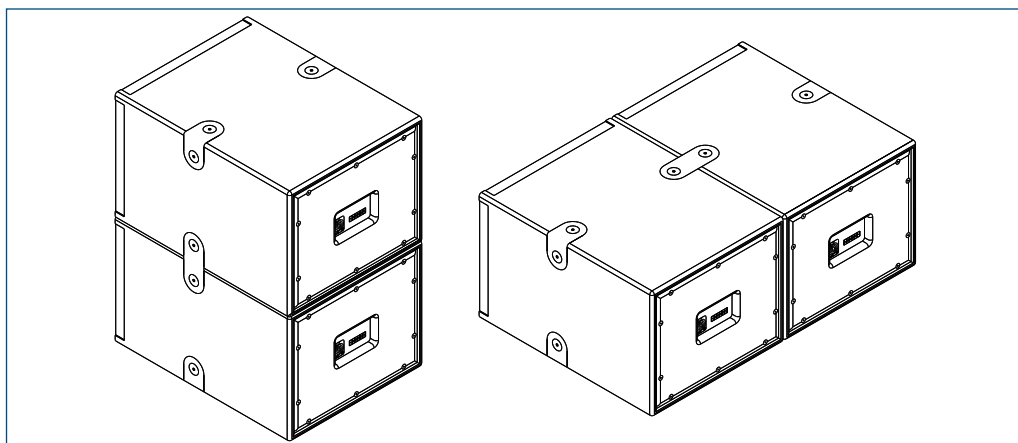

DIMENSIONS

