



▶ NEUMANN.BERLIN

▶ PRODUCT SELECTION GUIDE STUDIO PRODUCTS





Introduction

The choice of a loudspeaker or subwoofer from the Studio Systems range depends on a number of factors:

- System configuration
- Listening distance / room volume
- Required low frequency cut-off / replay level
- Available space
- Budget

Furthermore, the system should be balanced, i.e. one component in the system is not weaker than the rest of the system. For example, a system with under-specified subwoofer(s) will have limited low-frequency headroom. Or a system with small rear loudspeakers will struggle with high level sound panned to the rear channels.

It is possible to deliberately under-specify the entire system whilst keeping it balanced: the cost of this is limited maximum SPL and/or LF cut-off, but the system will be smaller and cheaper. Alternatively, one can deliberately over-specify the entire system whilst keeping it balanced: the advantage is that the system's distortion will be lower for a given replay level, however the cost is higher and more space is required.

One exception to this is over-specified subwoofer(s), which will have reduced low-frequency distortion resulting in a cleaner sounding bass.

Bass Management

Bass management redirects the LF energy of the main channels and some, or all, of the LFE channel energy to the subwoofer(s) in the reproduction system.

The advantages of bass management are:

- Subwoofer extends the LF cut-off of the system downwards
- Higher maximum system SPL
- Lower distortion
- Same phase, level, and frequency response of low frequency energy of the main and LFE channels
- Same coupling of the low frequency energy to the room on all main channels
- More flexibility in coupling the low frequency energy to the room as the subwoofer can be moved.

A block diagram of the 7.1 Channel High Definition Bass Manager™, as fitted to the **KH 810** and **KH 870** subwoofers, is shown on the next page.

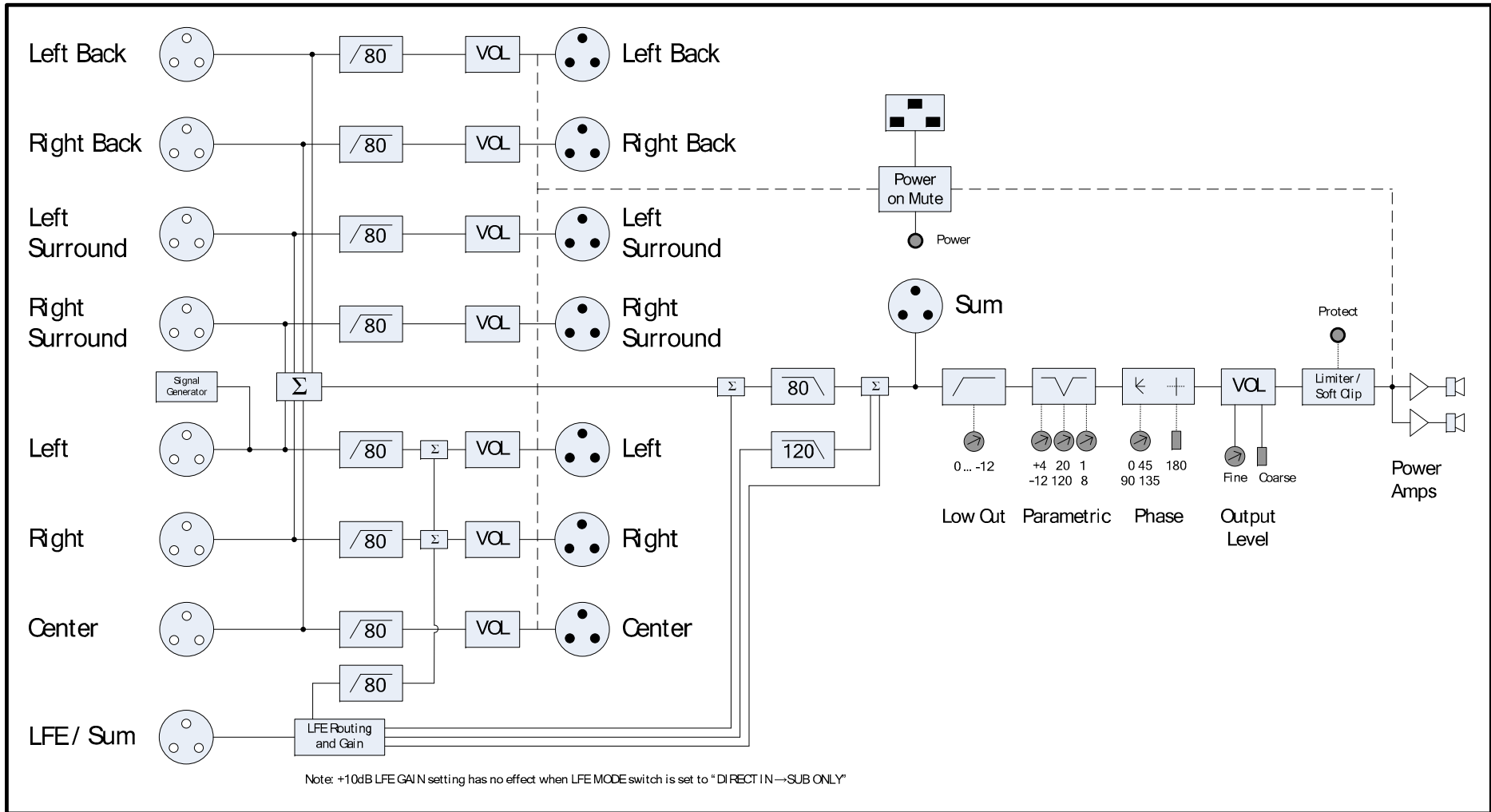

7.1 High Definition Bass Manager™



Listening Distance

To choose the appropriate **front** loudspeakers for your system, first use the listening distance to the front loudspeakers to find a model in the table below that fits within the **recommended** listening distance range column. Do not select a model where the listening distance is less than the **minimum** or greater than the **maximum** values shown. In all cases, the **front** loudspeakers (including the center) should be the same as each other.

Product	Most Common Application	Listening Distances		
		Minimum	Recommended	Maximum
KH 420	Midfield Monitoring	1.25 m (4')	1.5 - 3.0 m (5' - 9')	11 m (33')
KH 310	Nearfield Monitoring	0.75 m (2.5')	1.0 - 2.5 m (3' - 8')	6 m (18')
KH 120	Nearfield Monitoring	0.75 m (2.5')	1.0 - 2.0 m (3' - 6')	4 m (12')

In a studio application, the loudspeakers should be placed according to the ITU-R BS.775-1 recommendations so there is consistency of reproduction when compared to other listening environments. For movie applications, ANSI/SMPTE 202M is the preferred standard for system setup. For home use, as materials are mixed in ITU style rooms, one should get as close as possible to this configuration to maximize replay authenticity.

Loudspeaker Name	ITU-R BS.775-1 Angel	ANSI/SMPTE 202M Angel
Left	-30°	-22.5°
Center	0°	0°
Right	30°	22.5°
Left Surround	-110°±10°	An array to the left
Right Surround	110°±10°	An array to the right

For two-channel stereo, ±30° should be used. There are currently no internationally agreed standards for 6.1 or 7.1 formats. However common practice is to use one or two loudspeakers in the centre back location of a 6.1 system. In a 7.1 system common practice is to place side loudspeakers at ±90° and to push the surround loudspeakers back to ±150°.

The loudspeaker should be placed on a circle to ensure equal time of arrival of the audio from all loudspeakers. Failing this, appropriate electronic time delays should be added between the subwoofer and each loudspeaker to compensate for time of flight differences.



Balancing the System

Next, the other loudspeakers in the system (if required) should be chosen to match the main loudspeakers chosen.

Rear loudspeakers are typically the same model as the front loudspeakers, although it is possible to reduce the specification if space or budget is limited.

The **subwoofer(s)** should have sufficient output to keep up with the main loudspeakers, but can be over-specified for improved low-frequency system performance. Over-specifying the subwoofer section of system leads to lower LF distortion (cleaner audio), as each subwoofer does not have to work as hard.

Multiple smaller subwoofers (2 - 4 depending on the width of the room) distributed along the front wall create a plane wave that propagates from the front to the back of the room. This has the effect of reducing the interaction of the plane wave with the side wall. The consequence is less excitation of the side-to-side room modes and a better time-domain response. From a sound quality point of view, the low frequency reproduction will be tighter and cleaner. This is called a Plane Wave Bass Array™ (PWBA™).

The table on the next page ensures a well balanced system.

Table Notes:

- The “**Recommended**” column specifies the minimum recommended subwoofer solution to balance the entire system. Selecting a smaller subwoofer will limit the maximum output of the system.
- The “**High Performance**” column gives +6 dB of headroom over the recommended minimum subwoofer solution. The lower required replay level from the subwoofer(s) results in a substantially reduced low-frequency distortion. This specification is recommended for reproducing bass-heavy material in large and well-damped rooms.
- The “**Plane Wave Bass Array™**” column specifies two to four subwoofers (three to four for larger systems) that should be positioned along the front wall to generate a plane wave down the room. This reduces the side wall interaction thereby improving the side-to-side bass reproduction. The number of subwoofers arranged in a bass array depends on the width of the room: wider rooms, more subwoofers.
- If the system will eventually be upgraded for a larger channel count, select the loudspeakers and subwoofer(s) from the subwoofer(s) from that section.
- The same subwoofer specification is appropriate for 5.1 to 7.1 multichannel systems, even if the main channels are run full range, i.e. not bass managed.
- If space is insufficient for large cabinets, two **KH 810** subwoofers may be substituted in place of one **KH 870**.



	Fronts	Rears		Subwoofer			- 3 dB LF Cut-off (Max SPL at 3% THD)	
		Recommended	Smaller	Recommended	High Performance	Plane Wave Bass Array™	Without Sub	With Sub
2- Channel Stereo (2.0)	KH 420	-	-	KH 870	2 x KH 870	3-4 x KH 810	30 Hz (120.0 dB)	18 Hz (120.0 dB)
	KH 310	-	-	KH 810	KH 870	2-4 x KH 810	35 Hz (112.8 dB)	18 Hz (112.8 dB)
	KH 120	-	-	KH 810	KH 810	2-4 x KH 810	52 Hz (111.1 dB)	18 Hz (111.1 dB)
Matrix Multichannel Dolby Surround (3/1.0)	KH 420	KH 420	KH 310, KH 120	KH 870	2 x KH 870	3-4 x KH 810	30 Hz (120.0 dB)	18 Hz (120.0 dB)
	KH 310	KH 310	KH 120	KH 810	KH 870	2-4 x KH 810	35 Hz (112.8 dB)	18 Hz (112.8 dB)
	KH 120	KH 120	KH 120	KH 810	KH 810	2-4 x KH 810	52 Hz (111.1 dB)	18 Hz (111.1 dB)
Discrete Multichannel 5.1 (3/2.1) 6.1 (3/3.1) 7.1 (3/4.1)	KH 420	KH 420	KH 310, KH 120	2 x KH 870	3 x KH 870	3-4 x KH 810	30 Hz (120.0 dB)	18 Hz (120.0 dB)
	KH 310	KH 310	KH 120	KH 870	2 x KH 870	2-4 x KH 810	35 Hz (112.8 dB)	18 Hz (112.8 dB)
	KH 120	KH 120	KH 120	KH 810	KH 870	2-4 x KH 810	52 Hz (111.1 dB)	18 Hz (111.1 dB)
Larger Systems	Please contact your local distributor or Neumann for guidance as we have much experience with custom designed solutions for special applications.							



Checking the System Solution

Finally, using the table, check that the chosen system fulfills the requirements for LF cut-off and maximum SPL. If the chosen system does not satisfy the specification, a larger system will be required.

Also check interconnectivity:

- If you have analog outputs, choose “A” versions of the products (e.g. **KH 120 A** and **KH 310 A**). If you have digital outputs, choose “D” versions of the products (e.g. **KH 120 D** and **KH 310 D**).
- The **KH 420** is fitted with an analog input as standard.
- The **KH 810** and **KH 870** subwoofers have analog inputs and outputs only.

Systems for Movie Mixing

The above table assumes that all the channels in the system are bass managed – typical in the broadcast and music industries. In the movie industry, the main channels are produced entirely by the main loudspeakers, and only the LFE channel is reproduced by the subwoofer(s). In addition, each rear channel is often reproduced using multiple loudspeakers over, typically, half the listening distance. Each channel should reproduce long-term pink noise at a level of 85 dB(C) at the listening position. Use the table below for this type of system:

Front Loudspeakers	Subwoofer (s) for LFE only	Number of surround loudspeakers and type per channel			
		1	2	3	4
KH 420	KH 870	KH 420	KH 310	KH 120	KH 120
KH 310	KH 810	KH 120	KH 120	KH 120	KH 120
KH 120	KH 810	KH 120	KH 120	KH 120	KH 120



Mounting Hardware Selection Matrix

Our mounting hardware range philosophy is to supply the parts required to mount our loudspeakers onto commonly available third-party mounting products. For each product is listed in the table below the hardware that may be used to mount the loudspeaker in the specified way. Note that the hardware combinations are listed in the order in which they are attached to the product: starting with the cabinet and ending with the stand or surface to which it will be mounted.

Location of Loudspeaker	KH 420	KH 310	KH 120
Flush Mounted	REK 4 and CP <i>nn</i> for electronics	-	-
On a Floor Stand (tripod, TV spigot, or with a 5/8" thread)	LH41+LH28 LH41+LH36+LH28 LH41+LH29 LH41+LH36+LH29 LH41+K&M26795 LH41+ LH36+K&M26795	LH25+LH28 LH25+LH29 LH41+LH28 LH41+LH29 LH 41+LH36+LH28 LH 41+LH36+LH29 LH25+LH48+K&M26795 LH41+K&M26795 LH41+LH36+LH48+K&M26795 LH25+LH61+LH48+K&M26795	LH61 LH61+LH28 LH61+LH29 LH31+LH48+K&M26795
On a Stand (table or mic with a 5/8" thread)	-	-	LH61
On a Subwoofer (fitted with a flange)	(KH 870) LH41+LH37 LH41+LH36+LH37 LH41+LH28+pole LH41+LH36+LH28+pole	(KH 870) LH25+LH37 LH41+LH37 LH41+LH36+LH37 LH25+LH28+pole LH41+LH28+pole LH41+LH36+LH28+pole	(KH 870) LH61+LH37 LH61+LH28+pole



On a Meter Bridge or Table Top	-	No hardware required	LH65
On a Wall	LH42+LH45	LH25 LH25+LH43 LH25+LH47+LH45 Included rear panel brackets	LH32 LH45+LH47+LH61
Off a Ceiling	LH42+LH43 LH42+LH46	LH25 LH25+LH47+LH43 LH25+LH47+LH46	LH61 LH46+LH47+LH61 LH43+LH47+LH61
Off a Lighting or Truss Bar	LH42+LH29	LH25+LH29	LH29+LH61
On an Omnimount bracket	-	-	LH64
On a VESA mount bracket	-	-	LH64

The description “pole” in the table means a customer supplied pole (outside diameter = 35mm, 1.4”) to lift the main loudspeaker above the subwoofer. For stability reasons, the recommended maximum distance between the subwoofer and the loudspeaker 65 cm (2’).

Recommended König & Meyer (www.k-m.de) Stands and Accessories

Loudspeaker Stands	21435 (max 35 kg)	21436 (max 35 kg)	21450 (max 50 kg)	21455 (max 40 kg)	21460 (max 50 kg)	26720 (max 35 kg)
	26740 (max 35 kg)	26750 (max 35 kg)	21300 (max 50 kg)	21302 (max 30 kg)	26795 (max 35 kg)	
Microphone Stands	19900	20000	20120	20130		
Table Stands	22110	23200				
Wall mounts	24100 (max 50 kg)	24110 (max 50 kg)	24150 (max 50 kg)	24471 (max 15 kg)	24481 (max 25 kg)	

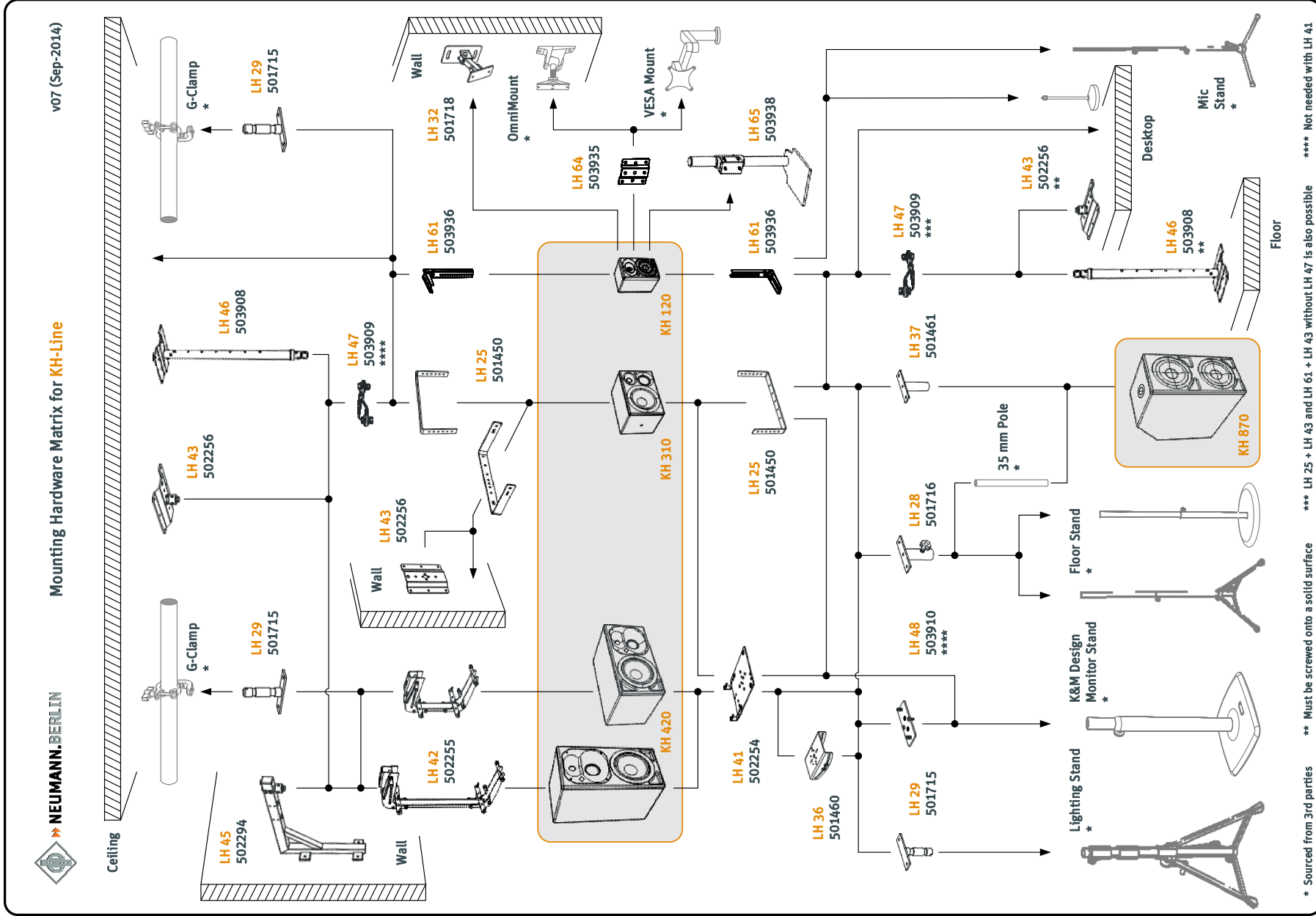

* Sourced from 3rd parties

** Must be screwed onto a solid surface

*** LH 25 + LH 43 and LH 61 + LH 43 without LH 47 is also possible

**** Not needed with LH 41

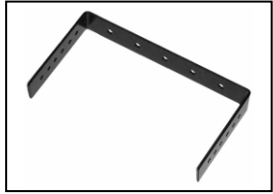

LH 25



LH 28



LH 29



LH 32

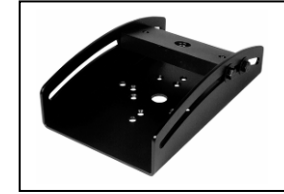

LH 36



LH 37



LH 41



LH 42



LH 43



LH 45



LH 46



LH 47

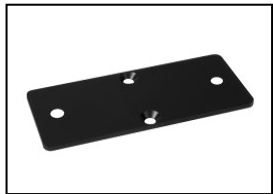

LH 48



LH 61



LH 64



LH 65



REK 4



REK 3

Version: 10

Date: 2-Sep-2014

Features and specifications are subject to change • Errors excepted, subject to changes