

DL32R

32-Channel Wireless Digital Live Sound Mixer with iPad® Control



The DL32R delivers 32-channels of powerful digital mixing that's completely controlled wirelessly from your iPad, freeing you to get in the mix like never before.

It's got convenient direct-to-drive multi-track recording/playback and an ultra-compact 3U rackmount design that lets you ditch the snake once and for all.

Fully loaded with DSP on each of the 32 Onyx+™ mic pres and 28 busses, the DL32R provides the power needed for professional applications.

The industry-proven Master Fader™ control app delivers extremely intuitive control over everything, including the ability to digitally recall each and every setting for incredibly fast setup.

Control everything from anywhere with the Mackie DL32R.



Like us



Follow us



Watch our dang videos

FEATURES:

- 32-Channel wireless digital mixer
 - 32 Onyx+™ recallable mic pres with wireless control
 - 14 fully-assignable XLR outputs
 - Stereo AES digital output
 - Total recall of all settings
 - 3U rackmount design ready for road or install
 - Card slot for Dante expansion card¹
- Wireless mixing¹
 - Complete control from your iPad®
 - No set FOH position – mix from anywhere
 - Personal monitor mixing via iPad, iPhone® or iPod touch®
 - Supports up to 10 separate iOS devices at once
 - Multiple engineers can work from a single mixer
 - Ditch the snake – place the mixer anywhere
- Multi-track recording & playback
 - 32x32 USB 2.0 audio interface for Mac or PC
 - 24x24 recording/playback direct to USB 2.0 hard drive
 - Wireless control over all direct-to-disk recording/playback functions
 - Record the show for later mixdown
 - Play back intermission music and backing tracks
 - Perform a virtual soundcheck
 - Amazing recording interface for the studio
 - Utilize Mac or PC audio plug-ins in a live environment
- Fully-loaded DSP
 - 36 input channels with 4-band PEQ + HPF, gate and compression
 - 32 stereo-linkable input channels
 - 4 stereo-linkable return channels¹
 - 28 output busses with 4-band PEQ + HPF/LPF, 31-band GEQ, comp/limiter and alignment delay
 - 14 stereo-linkable aux sends
 - 6 stereo-linkable matrix busses
 - 6 stereo-linkable subgroups¹
 - Main L/R busses
 - 6 VCAs and 6 mute groups
 - 3 stereo FX processors with dedicated sends and returns
 - Full I/O routing with A/B sources per channel
 - Modern and Vintage options per processor
- Master Fader control app
 - Intuitive and easy to master
 - Fast navigation with view groups and overview
 - Quick setup with tons of factory and user-definable presets
 - Access limiting prevents unwanted adjustments
 - Complete offline operation
 - Easy and frequent updates via App Store

¹ Dante expansion card coming soon (sold separately). Wi-Fi router and iPad required. Wi-Fi router, iPad, iPhone and/or iPod touch not included. Return channels and subgroups feature PEQ and compression.



DL32R 32-Channel Wireless Digital Live Sound Mixer with iPad® Control

DL32R SPECIFICATIONS

General Digital

Sample Rate:	48 kHz
A/D/A Bit Depth:	24-bit
System Latency:	1.5 ms
Analog Input > Main Bus > Analog Output	
0 dBFS Reference:	+22 dBu

Frequency Response

All inputs to all outputs:	±0, -1 dB, 20 Hz to 20 kHz
----------------------------	----------------------------

Distortion (THD)

Mic input to main output, 1 kHz, -1 dBFS:	<0.005%
---	---------

Noise / Dynamic Range / Signal-to-Noise Ratio

Equivalent Input Noise (EIN)	
150 Ω termination:	-128 dBu
Crosstalk	
Analog XLR input-input:	<-105 dB @ 1 kHz (min. gain)
Analog XLR / TRS output-output:	<-80 dB @ 1 kHz (max. gain)
Analog XLR / TRS output-output:	<-100 dB @ 1 kHz
Signal-to-Noise Ratio	
(ref +4 dBu, one channel and main fader at unity, A-weighted):	92 dB
Output Noise (A-weighted)	
Muted Output:	-90 dBu
Dynamic Range	
Analog Input to Analog Output	
(One channel and main fader at unity, A-weighted):	109 dB
Analog Input	
(Utility gain, to analog clipping, -60 dBFS signal, A-weighted):	111 dB
Analog Output	
(To analog clipping, -60 dBFS signal, A-weighted):	111 dB
CMRR:	>70 dB @ 1 kHz (60 dB gain)

Analog Inputs 1-32

Connectors	
1-24:	XLR Balanced
25-32:	Combo XLR / TRS Balanced
XLR Mic Pre:	Onyx+
Input Impedance	
1-24:	3 kΩ
25-32:	3 kΩ mic [XLR] 30 kΩ line [1/4"]
Max Input Level	
XLR:	+21 dBu
1/4":	+30 dBu
Gain [digitally controlled analog]	
XLR:	0 to 60 dB [3 dB steps]
1/4":	-20 to 40 dB [3 dB steps]
48V Phantom Power (XLR):	48 VDC, 10 mA max per mic, with up to 16 simultaneously. 5 mA max per mic, with up to 32 simultaneously. Individual digital controller per channel

Analog Outputs 1-12

Connectors:	XLR Balanced
Output Impedance:	600 Ω
Max Output Level:	+21 dBu

Analog Monitor Outputs L/R

Connectors:	1/4" TRS Impedance Balanced [Supports balanced / unbalanced operation]
Output Impedance:	240 Ω Balanced, 120 Ω Unbalanced
Max Output Level:	+21 dBu

Analog Headphone Out

Connector:	1/4" TRS Stereo
Max Output Level:	+18 dBu into 600 Ω +19.5 dBu max into 100 kΩ

AES Output

Format:	AES3 Professional, 48 kHz, 24-bit stereo
Connector:	XLR Balanced
Output Impedance:	110 Ω

USB - Streaming¹

Connection:	USB 2.0 High Speed (as a device)
Connector:	USB-B
Supported MS Windows	
[Driver installation required]:	Windows 7, 8
Supported Mac OS	
[Audio Class 2.0 Compliant, no driver required]:	OS X 10.8.4, 10.9
Audio:	32 in / 32 out, 48 kHz, 16/24-bit

USB - HDD Recording / Playback¹

Connection:	USB 2.0 High Speed (as a host)
Connector:	USB-A
Audio:	1-24 channel, 48 kHz, 16/24-bit (multichannel .wav)
Supported Devices:	USB 2.0 / 3.0 Class Compliant HDD
HDD Format:	FAT32
Bus Power:	5V, 1A max

¹ Streaming and HDD Record / Playback are not available simultaneously.



DL32R SPECIFICATIONS CONTINUED...

Networking

Connection [Using Basic Network Option Card]:	100 Mb Ethernet
Control:	Complete
Simultaneous Control:	10 iOS Devices

iPad Support

iOS Version Requirement:	8.0 or greater required
iPad Version Requirement Wireless:	iPad 2, iPad (3rd generation), iPad (4th generation), iPad mini, iPad mini retina, iPad Air
Control Application:	Mackie Master Fader App² Master Fader 3.0 or greater required

DSP

36 input channels with 4-band PEQ + HPF, gate and compression <ul style="list-style-type: none"> • 32 stereo-linkable input channels • 4 stereo-linkable return channels (PEQ and compression only)
28 output busses with 4-band PEQ + HPF/LPF, 31-band GEQ, comp/limiter and alignment delay <ul style="list-style-type: none"> • 14 stereo-linkable aux sends • 6 stereo-linkable matrix busses • 6 stereo-linkable subgroups (PEQ and compression only) • Main L/R busses
6 VCAs and 6 mute groups
3 stereo FX processors (2 reverb, 1 delay) with dedicated sends and returns
Full I/O routing with A/B sources per channel
Modern and Vintage options per processor

Power

Power Requirements:	100 VAC – 240 VAC, 50 – 60 Hz, Universal Supply
Power Consumption:	100 watts max
Line Cord:	User-replaceable IEC
Operating Temperature [extended ambient temperature]:	0 - 40 °C 32 - 104 °F

Physical Properties (packaged product)

Height:	8.8 in / 224 mm
Width:	21.2 in / 538 mm
Depth:	21.0 in / 533 mm
Weight:	23.0 lb / 10.4 kg

Physical Properties (product)

Height:	5.4 in / 138 mm
Width:	19.0 in / 483 mm
Depth:	17.5 in / 443 mm
Weight:	18.0 lb / 8.2 kg
Rack:	3U Rack Spaces

Ordering Information

DL32R 32-channel Wireless Digital Mixer with Master Fader iPad Control:	
~110V US	P/N 2042086-00
~230V EU	P/N 2042086-01
~230V UK	P/N 2042086-03
~240V AU	P/N 2042086-04
~230V CN	P/N 2042086-05
~120V BZ	P/N 2042086-06

² <https://itunes.apple.com/us/app/mackie-master-fader/id511500747?mt=8>

DL32R BLOCK DIAGRAM

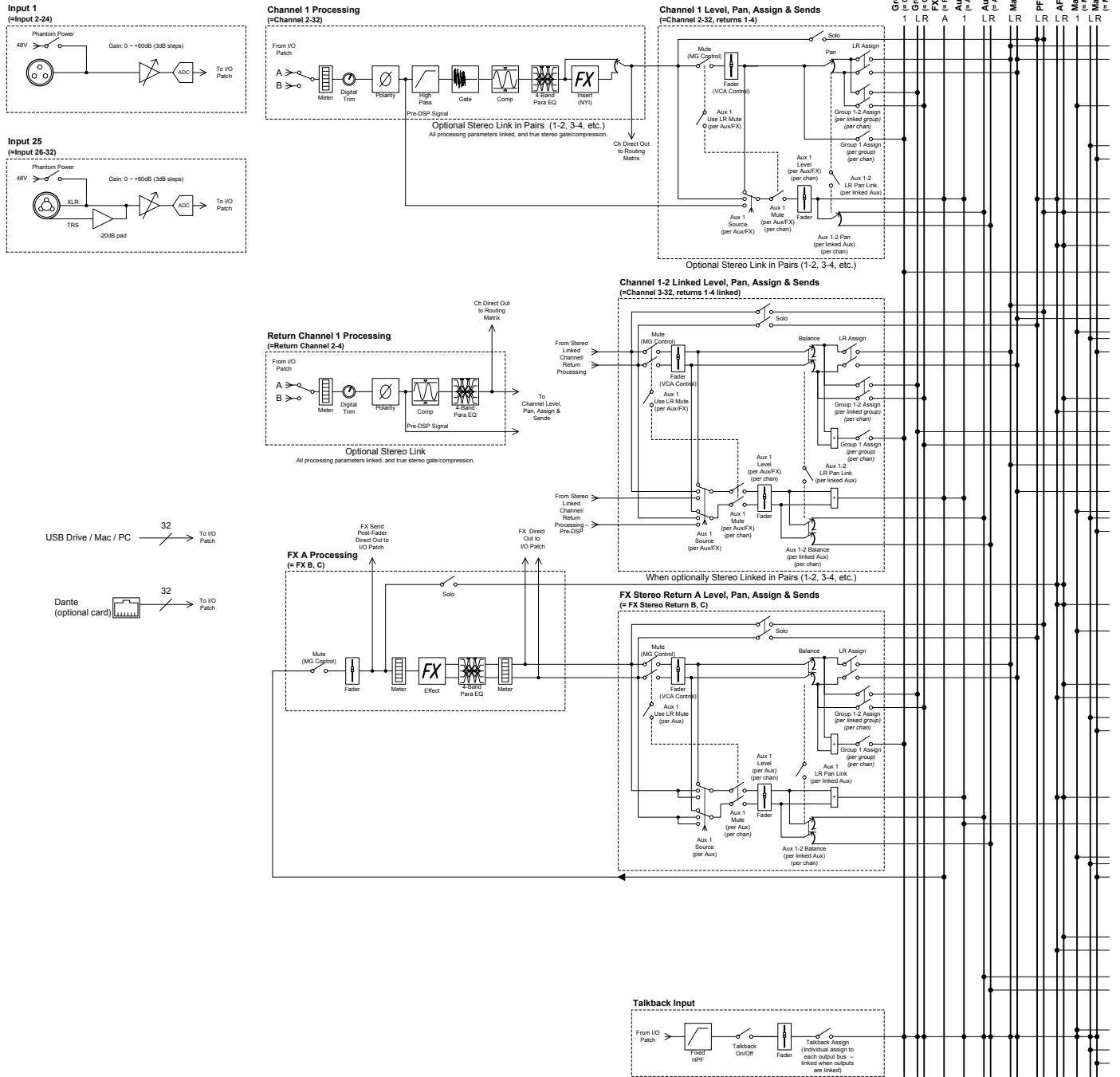

DL32R BLOCK DIAGRAM

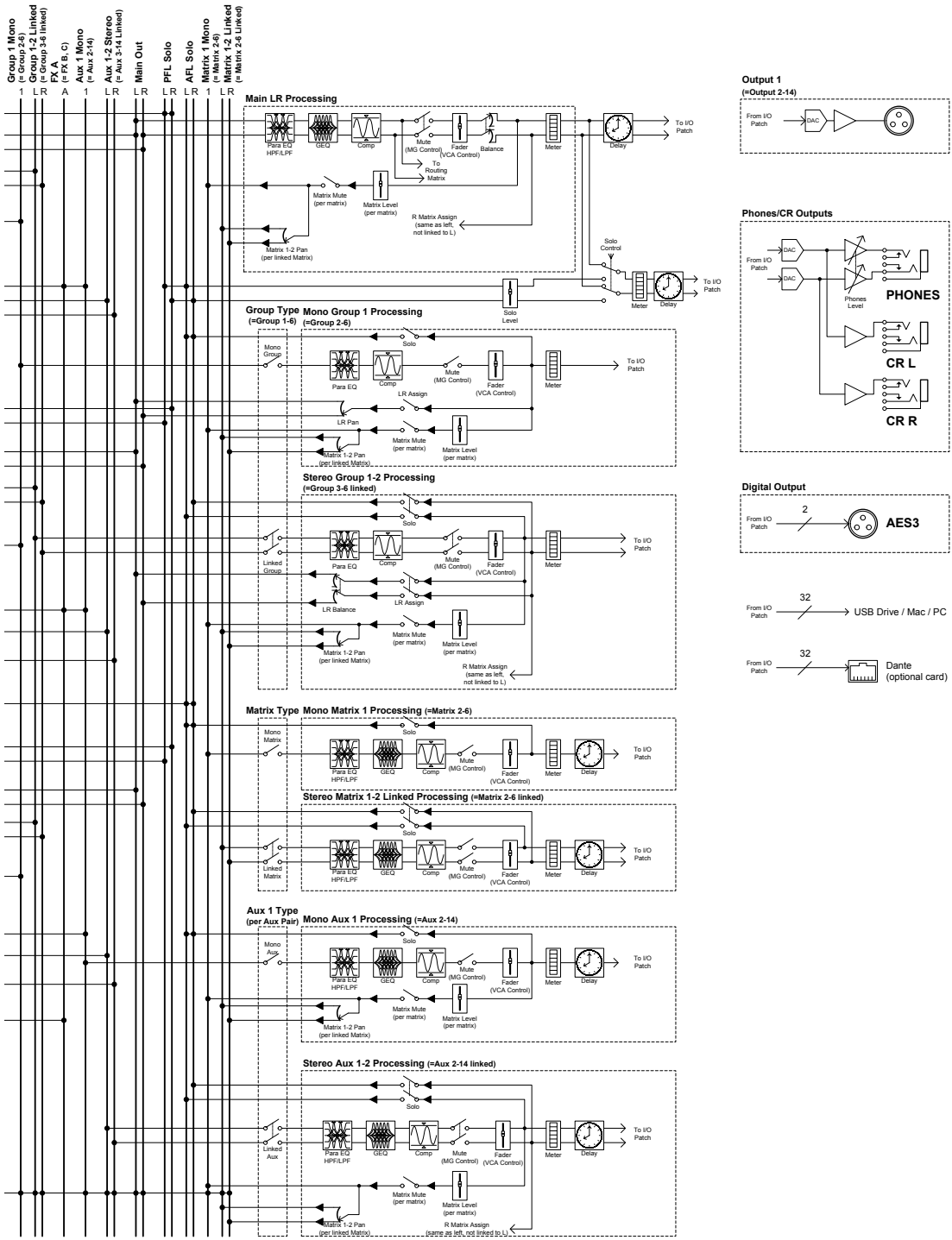

DL32R DIMENSIONS

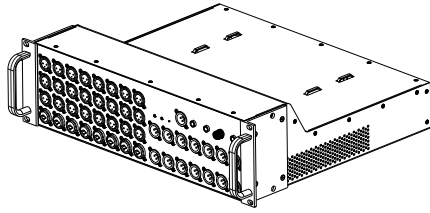

NOTES:

1. WEIGHT APPROX. 18.0 lb [8.2 kg].
2. SHIPPING WEIGHT APPROX. 23.0 lb [10.4 kg].

UNLESS OTHERWISE SPECIFIED: ALL DIMENSIONS ARE IN INCHES DUAL [MM] DIMENSIONS FOR REF ONLY

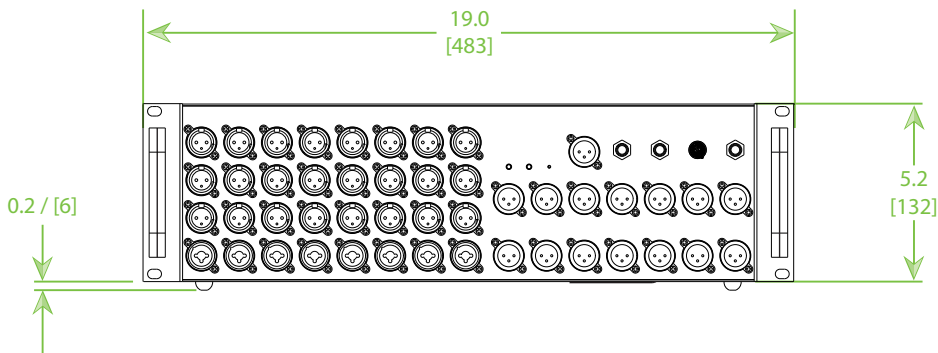
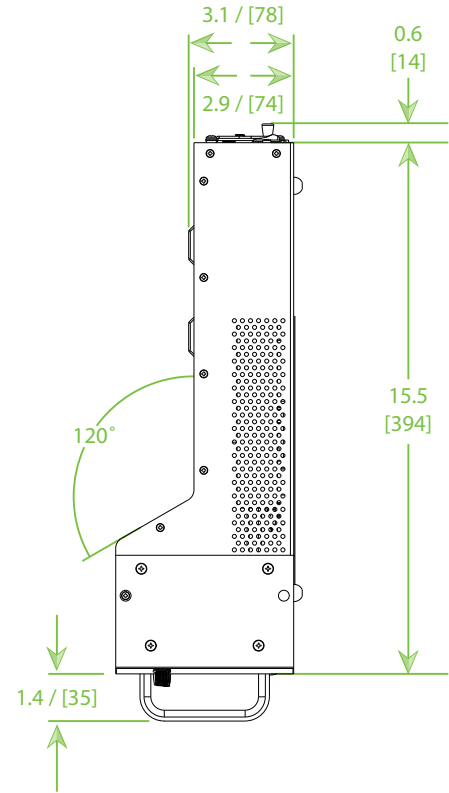
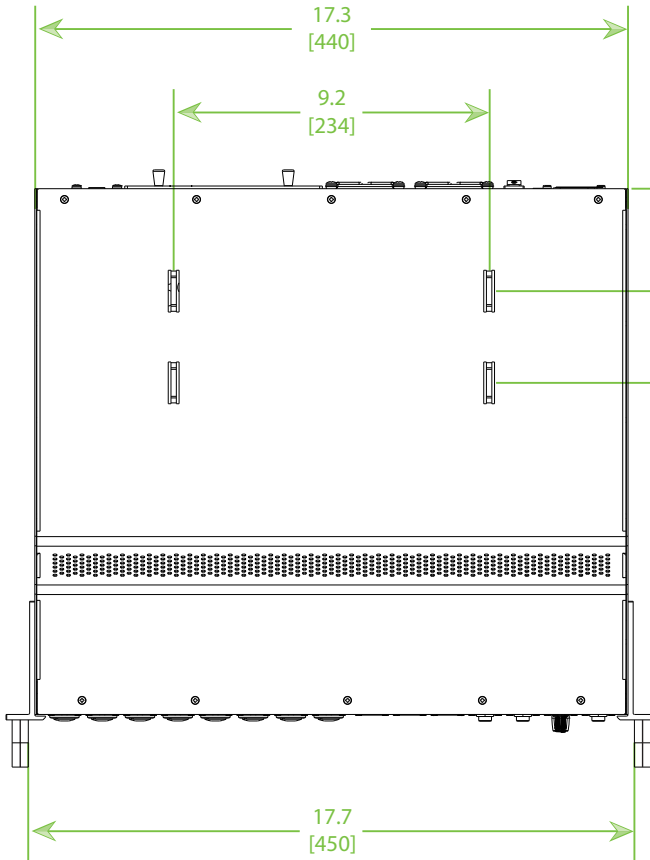



DL32R 32-Channel Wireless Digital Live Sound Mixer with iPad® Control

DL32R FRONT PANEL

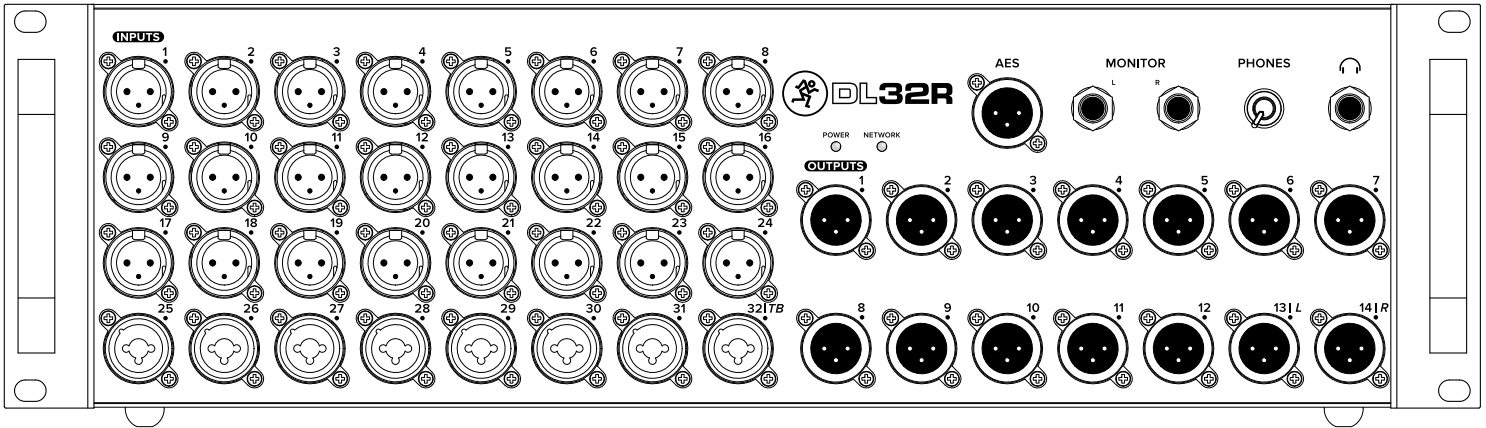

DL32R REAR PANEL

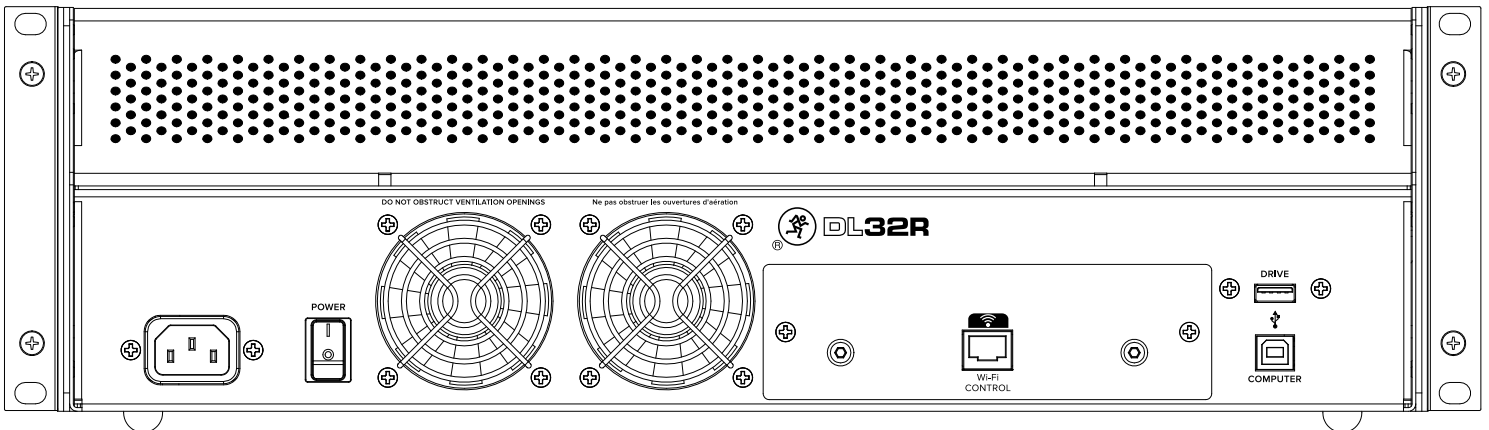

©2014 LOUD Technologies Inc. All rights reserved. Apple and iPad are registered trademarks of Apple, Inc., registered in the U.S. and other countries. All other marks are Registered Trademarks, or Trademarks, of LOUD Technologies in the United States and other countries. DL32R Patent Pending.

LOUD Technologies Inc. is always striving to improve our products by incorporating new and improved materials, components, and manufacturing methods. Therefore, we reserve the right to change these specifications at any time without notice.

Electronic files for this product are available at:

www.mackie.com

Specification Sheet	DL32R_SS.PDF
Reference Guide	DL32R_OM.PDF



www.mackie.com
16220 Wood-Red Road NE
Woodinville, WA 98072 USA
800-898-3211, Fax 425-487-4337, sales@mackie.com

Part No. SWI077 Rev. A 10/14