

4.3" Modero X[®] Series Wall/Flush Mount Touch Panel

MXD-430-P (FG5968-15) Portrait Wall Mount Touch Panel



Overview

The Modero X Series is the most elegant family of interfaces designed specifically for dedicated room control. This new generation of touch panels is built for usability offering edge-to-edge capacitive touch glass with multi-touch capabilities. It features advanced technology empowering users to operate AV equipment seamlessly, while providing the ultimate in audio and video quality. The distinctive appearance will complement even the most sophisticated meeting facilities and homes. With a lightning fast processor, brilliant graphics and enhanced capabilities, the Modero X Series is the control surface that simply delivers more.

Common Applications

The MXD-430 is ideal for boardrooms, conference rooms or podiums where a control surface is needed to provide access to key functions. In residences, it is perfect for kitchens, bedrooms or home offices where it can be used to manage systems throughout the home..

Features

- **Latest Communication Technologies** – Supports Near Field Communication (NFC) - short-range wireless technologies that deliver peer-to-peer communication by 'sharing, pairing and transaction' between RF devices like exchanging data/identities
- **Enhanced Usability** – External phone connections via Bluetooth or USB and HD video streaming
- **Graphic Leaps & Bounds** – The Modero X Series features intuitive UI functionality including: gesturing, swiping, dynamic reordering and enhanced animation capabilities
- **Perfect From Any Angle** – Includes In-Plane Switching (IPS), the latest technology in popular tablet/mobile devices that delivers the widest viewing angles and the most accurate color reproduction on the market
- **Programmable LEDs** – red/green LEDs on the left and right sides useful for indicating when a conference room is available or in use

Dealer Benefits

- **Attract More Corporate Customers** - The elegant design and simple beauty of the Modero X Series will create demand from both new and current customers
- **Address Unique Requirements** – With edge-to-edge glass and capacitive touch, the Modero X Series Touch Panels provide dealers with a control surface that is unobtrusive and simple to use
- **Differentiate Yourself** – The Modero X Series offers design and technology features unmatched in the industry

Customer Benefits

- **Simple to Use Interfaces** – The capacitive multi-touch and gesture-based screen makes it easy for anyone to operate sophisticated meeting room equipment and whole home systems
- **Range of Sizes** – The contemporary design with edge-to-edge glass is available in 4.3", 7", 10.1" as well as 19.4" and 20.3" panoramic sizes for applications in any room
- **Vertical Orientation** - The 4.3" Modero X Series Wall/Flush Mount Touch Panel is engineered to mount vertically for specific applications such as room scheduling

Specifications

TOUCH SCREEN DISPLAY	
Display Type	TFT Active Matrix Color LCD with In-plane Switching Technology (IPS)
Display Size (WH)	3.3" x 4.8" (82 mm x 120 mm), 4.9" (119 mm) diagonal
Viewable Area (WH)	2.2" x 3.7" (56 mm x 94 mm), 4.3" (109 mm) diagonal
Resolution (WH)	480x800
Aspect Ratio (WH)	9:16
Brightness	550 cd/m2
Contrast Ratio	1000:1
Color Depth	16.7M colors
Illumination	LED
Touch Overlay	Projected Capacitive, multi-touch support, 3 simultaneous max
Viewing Angle	Vertical ± 80°, Horizontal ± 80°

MEMORY	
SDRAM	512 MB
Flash	4 GB
Maximum Project Size	2.4 GB flash available to user

COMMUNICATIONS	
ETHERNET	10/100 port, RJ-45 connector. Supported IP and IP-Based Protocols: UCP, TCP, ICMP, ICSP, IGMP, DHCP, Telnet, FTP, DNS, RFB (for VNC), HTTP
USB	(1) USB host 2.0, Type A port: Firmware upgrade, touch panel file transfer, JPEG image viewer
Near Field Communication (NFC)	Supports standards ISO/IEC 15693, ISO/IEC 14443A, ISO/IEC 14443B; Unique Identifier (UID), typ range = .25", max = .5"
Bluetooth	Mouse/Keyboard: HID Profile v1.1, requires MXA-BT Bluetooth Adapter (FG5968-19) Handset: Hands Free Profile v1.5, Headset Profile v1.2, requires MXA-BT Bluetooth Adapter (FG5968-19) and MXA-HST Bluetooth Handset (FG5968-17)

VIDEO	
Supported Video Codecs	MPEG-2-TS: MPEG-2 Main Profile@High Level up to 720p at 25 fps (decode only) MPEG-2-TS: H.264 High Profile@Layer 4, AAC-LC up to 720p at 25 fps (decode) MJPEG up to 720p at 25 fps (decode only)
Supported Video Transport Streams	MPEG-TS for MPEG2 and H.264; HTTP for MJPEG
Max Number of Active Video Streams	One decode

AUDIO	
Microphone	-42dB +- 3dB sensitivity FET microphone
Speakers	4 ohm, 2 Watt, 300 Hz cutoff frequency
Supported Audio Codecs	MP2 Layer I and II, MP3 (8 kHz, 11.025 kHz, 12 kHz, 16 kHz, 22.05 kHz, 24 kHz, 32 kHz, 44.1 kHz, 48 kHz) AAC-LC (8 kHz, 96 kHz) G.711 with μ Law (VoIP encode/decode at 8kHz)
Audio Output	USB Audio out USB port (head/Hand set support)
File Formats	WAV, MP3 (as part of touch panel file only - no USB storage)
Intercom	Full Duplex VoIP, SIP v2.0 (supported with AMX-CSG)

GRAPHICS ENGINE	
AMX G4	G4 enhanced feature set supporting multi-touch and gestures, scrolling, transitions - See TPD4 Operations Guide for more information

EMBEDDED APPLICATIONS	
Remote Management	VNC Server, G4 Web Control, AMX Resource Management Suite
Video Conferencing	Panel-to-panel and video chat (the MXD-430 receives video and returns audio)
Audio Conferencing	Audio (full duplex intercom)

FRONT PANEL COMPONENTS	
Light Sensor	Photosensitive light detector for automatic adjustment of the panel brightness
Proximity Detector	Max range = ~3', typ range = ~1', FOV = ~10 degrees
Sleep Button	Sleep button to activate sleep mode and powering off. Also provides access to setup pages (can be disabled)
Programmable Red/Green LEDs	Programmable red/green LED recessed in the left and right sides of the panel

CONNECTIONS	
Ethernet	10/100 port, RJ-45 connector
USB	(1) USB host 2.0, Type A port
Power	PoE (Power over Ethernet), 802.3af, class 3

ENVIRONMENTAL	
Temperature (Operating)	32° F to 104° F (0° C to 40° C)

Temperature (Storage)	4° F to 140° F (-20° C to 60° C)
Humidity (Operating)	20% to 85% RH
Humidity (Storage)	5% to 85% RH
Power ("Heat") Dissipation	On: 22.2 BTU/hr, Standby: 14.3 BTU/hr

GENERAL	
Dimensions (HWD)	4 7/8" x 3 1/4" x 2 3/8" (120 mm x 82 mm x 61 mm)
Weight	0.75 lbs (.34 Kg)
Power Consumption	Full-On: 6.5 W (max) Standby: 4.2 W Shutdown: 1.9 W
Start-Up Inrush Current	Not applicable due to PoE standard
External Power Supply Required	AMX recommends using one of these AMX approved PoE power supplies (not included): PS-POE-AF-TC, PoE Injector, 802.3AF Compliant (FG423-83) NXA-ENET8-2POE, Gigabit PoE Ethernet Switch (FG2178-63)
Certifications	UL 60950-1 FCC Part 15 Class B C-Tick CISPR 22 Class B CE EN 55022 Class B and EN 55024 CB Scheme IEC 60950-1 IC IEC/EN-60950 RoHS/WEEE compliant
Included Accessories	MXA-USB-C, USB Port Cover Kit, Modero X Series Touch Panel (FG5968-18) MXA-CLK, Modero X Series Cleaning Kit (FG5968-16)
Optional Accessories	MXA-MPL, Modero X Series Multi Preview Live (FG5968-10) MXA-MP, Modero X Series Multi Preview (FG5968-20) PS-POE-AF-TC, PoE Injector, 802.3AF Compliant (FG423-83) CB-MXP43, Rough-In Box and Cover Plate for Modero X Series Touch Panel, 4.3" (FG039-19) MXA-BT Bluetooth USB Adapter for Modero X Series (FG5968-19) MXA-HST Modero X Series Bluetooth Handset (FG5968-17) NXA-ENET8-2POE, Gigabit PoE Ethernet Switch (FG2178-63) MXA-CLK, Modero X Series Cleaning Kit (FG5968-16) CSG, Communications Gateway (FG2182-01, -02, -03)

For a more detailed pictorial drawing please visit: http://www.amx.com/assets/drawings/95-5968-15_REV-B.pdf

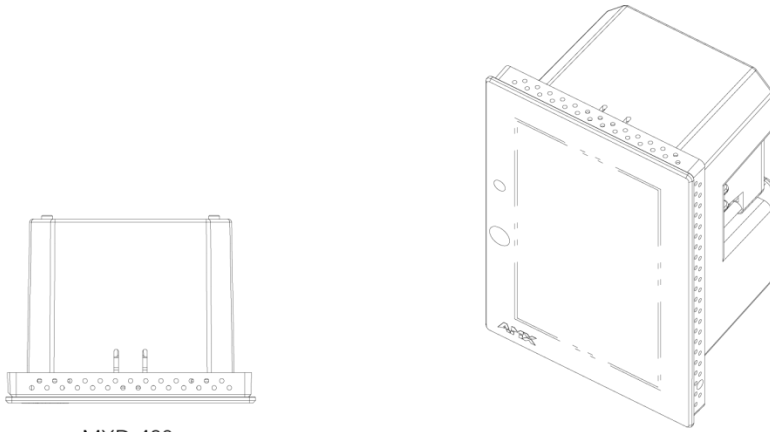

MXD-430
(Top View)

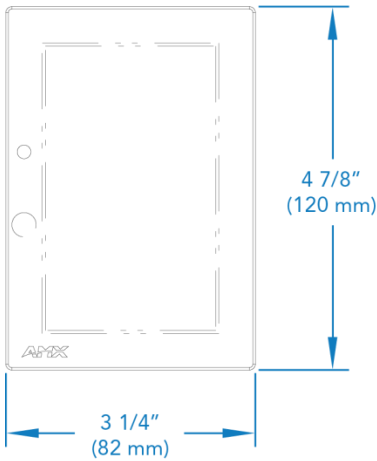

MXD-430
(Front View)

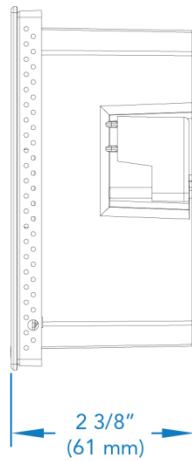

MXD-430
(Right View)

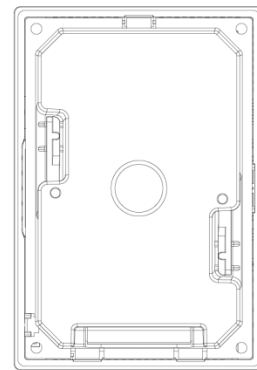

MXD-430
(Back View)

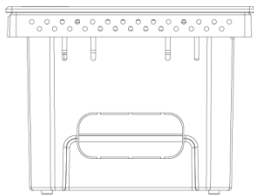

MXD-430
(Bottom View)

About AMX

AMX hardware and software solutions simplify the implementation, maintenance, and use of technology to create effective environments. With the increasing number of technologies and operating platforms at work and home, AMX solves the complexity of managing this technology with reliable, consistent and scalable systems. Our award-winning products span control and automation, system-wide switching and audio/video signal distribution, digital signage and technology management. They are implemented worldwide in conference rooms, homes, classrooms, network operation / command centers, hotels, entertainment venues, broadcast facilities, and more. ©2013 AMX. All rights reserved. **Specifications subject to change. Revised 26-March-2013.**

AMX.com | 800.222.0193 | 469.624.8000 | +1.469.624.7400 | fax 469.624.7153