

Portable Memory Recorder

Operating Instructions

Before operating the unit, please read this manual thoroughly and retain it for future reference.

PMW-RX50

XDCAM **SxS** **HDMI**

mPEG HD422 **i** **XAVC**

Table of Contents

Overview

Part Identification	5
Front View	5
Rear View	6
Top Panel	6
Audio Input Box (Supplied)	7
IR Remote Commander (Supplied)	7
On-Screen Indications	9
Software Downloads	10

Preparations

Power Supply	11
Using a Battery Pack	11
Using AC Power (DC IN Power)	12
Turning the Power On/Off	12
Setting the Clock	12
Using SxS Memory Cards	13
Using Other Media	15
Removing and Attaching the Audio Input Box	16
Removing the Audio Input Box	16
Attaching the Audio Input Box	16
Using a Wi-Fi Connection	17
Attaching the CBK-WA100	17
Connecting to Wi-Fi with the CBK-WA100	18
Using the Web Menu	18
Using Wi-Fi Remote Control	19

Recording

Changing Basic Settings	21
Selecting an Input Signal	21
Video Formats	21
Time Data	23
Setting the Output Mode	23
Recording	24
Useful Functions	25
Color Bars/Reference Tone	25

Shot Marks	UDF	exFAT	FAT/HD	25
OK/NG/KP Flags	UDF	exFAT		25
OK Mark	FAT/HD			25
Assignable Buttons				26
Clip Continuous Recording	UDF	exFAT		26
Loop Recording	UDF	exFAT		27
Deleting Clips				27
Storing/Retrieving the Setting Data				28
Planning Metadata				28

Playback

Thumbnail Screens	32
Configuration of the Thumbnail Screen	32
Changing the Type of Thumbnail Screen	33
Playing Clips	34
Playing the Selected and Subsequent Clips in Sequence	34
Playing between In-point and Out-point	34
Playing Clips in Repeat Mode	35
Monitoring Audio	35
Cueing Up	35
Clip Operations	36
Clip Operation Menus	36
Basic Operations of the Clip Operation Menus	36
Displaying the Detailed Information of a Clip	38
OK/NG/KP Flag	UDF exFAT 38
OK Mark	FAT/HD 39
Copying Clips	39
Deleting Clips	39
EXPAND CLIP Screen	39
SHOT MARK Screen	UDF exFAT FAT/HD 41
Changing the Index Frame	UDF exFAT FAT/HD 42
Dividing a Clip	FAT/HD 42

Status Displays

Showing the Status Screens	43
Audio Status Screen	43
Video Status Screen	43
Button/Remote Status Screen	44
Battery/Media Status Screen	44

Menu Configuration and Detailed Settings

Overview of the Setup Menus	45
Setup Menu Layers	45
Basic Menu Operations	46
Setup Menu List	47
[AUDIO SET] Menu	47
[VIDEO SET] Menu	49
[LCD SET] Menu	52
[TC/UB] SET Menu	53
[OTHERS] Menu	54

Connecting External Devices

Connecting External Monitors and Camcorders	65
Connecting Audio Equipment	66
Connecting a Computer	67
Connecting via i.LINK	68
Recording the Image on an External Device FAT	68
Nonlinear Editing FAT	68
Recording and SDI Output of External Input Signals	69
Connecting USB Media	70
Supported USB Media	70
Copying Clips	70
Displaying the USB Media Thumbnail Screen	70

Appendices

Important Notes on Operation	72
Recording Video Formats ([Rec Format])	74
Formats and Limitations of Outputs	76
Backup Battery Replacement	83
Troubleshooting	84
Licenses	88
MPEG-4 AVC Patent Portfolio License	88
MPEG-2 Video Patent Portfolio License	88
Bitmap Fonts	88
On accessing software to which the GPL applies	88
About OpenSSL	88
About JQuery,Sizzle.js	91
Specifications	91

Overview

Part Identification

For functions and usage, see the pages in parentheses.

Front View

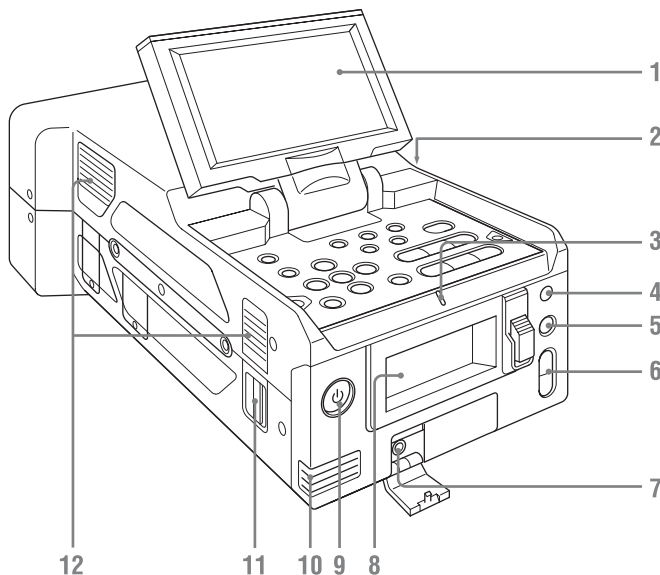

The above is an illustration with the audio input box removed. For details on the parts of the audio input box, see “Audio Input Box (Supplied)” (page 7).

1. LCD monitor

The LCD monitor LCD can be rotated 180° in the clockwise direction and 90° in the counterclockwise direction when it is open. It can also be stowed on the top surface of the recorder with the screen facing up.

To rotate the LCD monitor, tilt it toward you (approximately 80°) and then turn it sideways.

2. Exhaust vent

Do not block the exhaust vent.

3. TALLY lamp

4. Infrared light receiver sensor

5. SLOT SELECT button

6. VOLUME buttons

7. Headphone connector

8. Memory card slots (page 13)

9. Power button/lamp (page 12)

10. Built-in speaker

11. Shoulder strap mounting points

The supplied shoulder straps mount as shown in the following diagram.

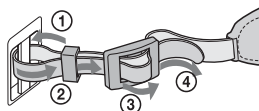

12. Intake vent

Do not block the intake vent.

Rear View

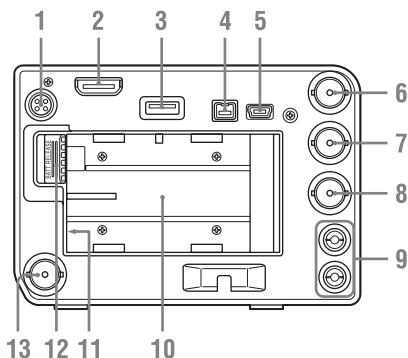

1. DC OUT connector (4-pin) (for CBK-WA100) (page 18)

Note

When operating on battery power, the voltage output will be that of the battery.

2. HDMI OUT connector (page 65)
3. External device connector
Connect a CBK-WA100 Wireless Adapter (not supplied), an IFU-WLM3 USB Wireless LAN Module (not supplied), or a USB flash drive here.
When a CBK-WA100/IFU-WLM3 is connected: You can connect the recorder to a computer via a Wi-Fi (wireless) connection.
When a USB flash drive is connected: You can record, save, and load the following data.
 - Planning metadata (page 28)

Note

Use this connector only for the CBK-WA100, IFU-WLM3, USB flash drives, and USB media. Do not connect and use USB hubs and other devices.

For details on Wi-Fi connections, see "Using a Wi-Fi Connection" (page 17).

4. i.LINK (HDV/DV) connector (4-pin, IEEE1394 S400-compliant) (page 65)
5. PC connector
6. SDI IN (serial digital input) connector (BNC type) (page 65)
7. SDI OUT 1 (serial digital output) connector (BNC type) (page 65)

8. VIDEO OUT (analog video output) connector (BNC type) (page 65)
9. AUDIO OUT (analog audio output) connector (CH-1/CH-2) (page 65)
10. Battery pack receptacle (page 11)
11. DC IN (DC power supply input) connector (page 12)
12. BATT RELEASE (battery release) button (page 11)
13. SDI OUT 2 (serial digital output) connector

Note

Power can only be supplied to an external device from either the DC OUT connector or the external device connector. They cannot both be used to supply power at the same time.

Top Panel

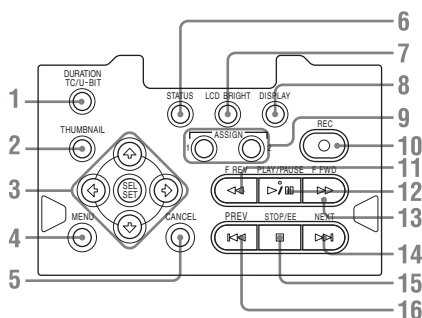

1. DURATION/TC/U-BIT (time data selection) button (page 23)
2. THUMBNAIL (thumbnail display) button (page 32)
3. Up/Down/Left/Right buttons, SEL/SET (select/set) button (page 46)
Press the left/right buttons during playback/pause to play in slow motion.
4. MENU (menu display ON/OFF) button (page 46)
5. CANCEL button (page 46)
6. STATUS (status display selection) button (page 43)
This can also be used as the ASSIGN 3 (assignable) button (page 26).

7. LCD BRIGHT (LCD monitor brightness adjustment) button

This can also be used as the ASSIGN 4 (assignable) button (page 26).

8. DISPLAY button (page 9)

This can also be used as the ASSIGN 5 (assignable) button (page 26).

9. ASSIGN 1/2 (assignable) buttons (page 26)

10. REC (record) button (page 24)

11. F REV (fast reverse playback) button (page 35)

12. PLAY/PAUSE button (page 34)

13. F FWD (fast forward playback) button (page 35)

14. NEXT (next clip) button (page 35)

15. STOP/EE (button) (pages 24 and 32)

16. PREV (previous clip) button (page 35)

Audio Input Box (Supplied)

The audio input box is removable. For details, see “Removing and Attaching the Audio Input Box” (page 16).

Front

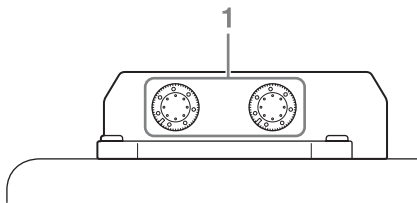

Rear

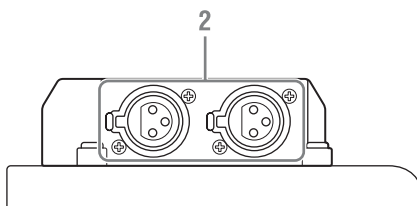

1. AUDIO LEVEL CH-1/CH-2 adjustment knobs (page 66)

2. AUDIO IN CH-1/CH-2 connectors (page 66)

To input audio signals to the AUDIO IN connectors, [Audio Input] (page 47) must be configured in the [AUDIO SET] menu.

IR Remote Commander (Supplied)

Before use, pull out the insulation sheet.

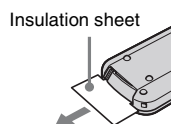

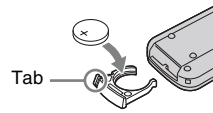
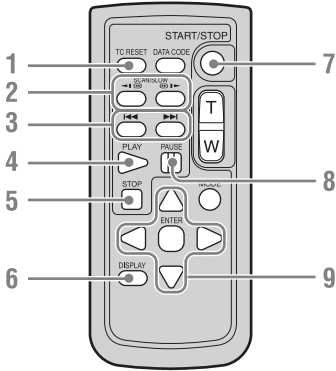

WARNING

- Battery may explode if mistreated. Do not recharge, disassemble, or dispose of in fire.
- Batteries shall not be exposed to excessive heat such as sunshine, fire or the like.

CAUTION

Danger of explosion if battery is incorrectly replaced. Replace only with the same or equivalent type recommended by the manufacturer.

When you dispose of the battery, you must obey the law in the relative area or country.

1. **TC RESET (timecode reset) button**
2. **SCAN/SLOW ◀▶ (fast reverse playback / fast playback) buttons**
3. **◀▶ (previous/next clip) buttons**
4. **PLAY button**
5. **STOP button**
6. **DISPLAY (screen display) button**
7. **START/STOP (recording start/stop) button**
8. **PAUSE button**
9. **◀/▶/▲/▼/ENTER buttons**

Notes

- The DATA CODE, T/W (zoom), and MODE buttons are not used with this recorder.
- To avoid malfunctions, the remote control function is automatically deactivated when the recorder is turned off. Activate the function each time when required after you turn the recorder on.

Replacing the battery in the IR Remote Commander

Use a commercially available CR2025 lithium battery. Do not use any battery other than a CR2025.

- 1 **Press the tab inward and grasp it with your fingernail to pull out the battery case.**
- 2 **Insert the new battery with its + side facing up.**
- 3 **Insert the battery case until it clicks into place.**

On-Screen Indications

While recording or in standby mode, pressing the DISPLAY button displays the status and settings of this unit on the LCD monitor.

Remarks

[M]: The indication of the items named with this suffix can be independently turned on/off with [Display On/Off] in the [LCD SET] menu (page 52).

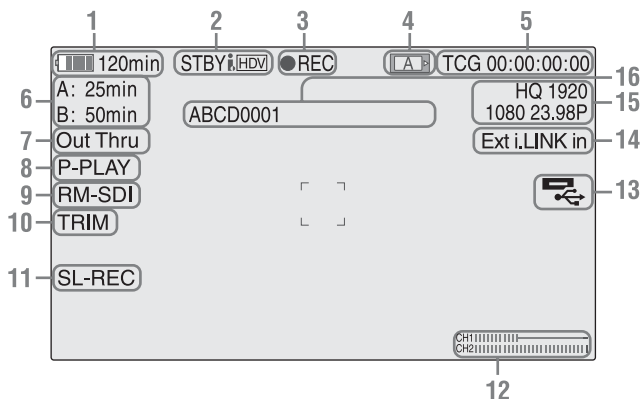

1. Battery remaining/DC IN voltage indication **[M]** (page 11)

2. i.LINK status indication (page 68)

Only when an external device is connected to the i.LINK connector, the status of the device is displayed.

3. Special recording/operation status indication

●REC	Recording in progress
STBY	Standby for recording
CONT (lit)	When using Clip Continuous Recording, indicates that a clip is being continued.
CONT (flashing)	When using Clip Continuous Recording, indicates there is no continuing clip.

4. Media status indication

Displays the active memory card slots.

5. Time data indication **[M]** (page 23)

6. Media remaining indication **[M]** (page 14)

7. Output mode indication (page 23)

Displays “Out Thru” when the output mode is set to [THROUGH], or [Out Auto] when the output mode is set to [AUTO].

8. In-point to out-point partial playback indication (page 34)

Displays “P-PLAY” when playing the interval from the in-point to the out-point.

9. Synchronous recording indication **[M]**

Displays “RM-SDI” when [SDI Rec Control] in the [VIDEO SET] menu is set to [On]. Displays “Rec2” when the REC trigger signal is output when using the CBK-WA100.

10. Trim indication (page 35)

11. Loop recording indication (page 27)

Displayed when loop recording.

12. Audio level meters **[M]**

13. USB media icon indication (page 70) or wireless adapter status indication

Displays an icon when valid USB media (HDD, flash drive, or other USB device) is connected. If the media is protected, a lock mark appears. If a CBK-WA100 wireless adapter is connected, it displays the wireless status, SD card remaining capacity, and clip transfer status.

14. Input signal indication

Displayed when a signal is input from the input source selected by [Input Source Select] in the [VIDEO SET] menu.

Ext SDI in	Input from the SDI IN connector
Ext i.LINK in	HDV/DVCAM input from the i.LINK connector
SG	Color bar output

Note

If the indication is blinking, check whether [REC Format] matches the input signal and whether the input signal is distorted.

15. Video Format indication [M] (page 21)

16. Clip name indication [M] (page 24)

Software Downloads

When the unit is used with a PC connection, download any device drivers, plug-ins, and application software you require from the following websites.

Sony Professional products website:	
U.S.A.	http://pro.sony.com
Canada	http://www.sonybiz.ca
Latin America	http://sonypro-latin.com
Europe,	http://www.pro.sony.eu/pro
Middle East, Africa	http://sony-psmea.com
Russia	http://sony.ru/pro/
Brazil	http://sonypro.com.br
Australia	http://pro.sony.com.au
New Zealand	http://pro.sony.co.nz
Japan	http://www.sonybsc.com
Asia Pacific	http://pro.sony-asia.com
Korea	http://bp.sony.co.kr
China	http://pro.sony.com.cn
India	http://pro.sony.co.in

Sony Creative Software, software download page:
http://www.sonycreativesoftware.com/download/software_for_sony_equipment

You can use a battery pack or AC power via an AC adaptor.

For safety, use only the Sony battery packs and AC adaptor listed below:

Lithium-ion Battery Pack

BP-U30/BP-U60/BP-U90

Battery Charger/AC Adaptor

BC-U1/BC-U2

WARNING

Batteries shall not be exposed to excessive heat such as sunshine, fire or the like.

Note

The AC adaptor cannot be connected to the recorder while the battery pack is inserted.

Using a Battery Pack

Fully insert the battery pack into the battery pack receptacle (*page 6*), then slide it to the right to lock it.







To remove the battery pack, press and hold the BATT RELEASE button (*page 6*), slide the battery pack to the left to unlock it, then pull it out.

Notes

- Before use, charge the battery pack with the supplied BC-U1 or BC-U2 Battery Charger.
- A warm battery pack immediately after use may not be able to be fully recharged.
- The high-capacity BP-U90 Battery Pack is large, and protrudes from the recorder when attached.

Checking battery charge remaining

When recording or playback is in progress on the battery pack, an icon to show the current battery charge level and usage time remaining are displayed on the LCD monitor (*page 9*).

Icon	Remaining
	100% to 91%
	90% to 71%
	70% to 51%
	50% to 31%
	30% to 11%
	10% to 0%

The recorder indicates the remaining usage time in minutes if operation is continued at the current rate of power consumption.

If the battery charge remaining becomes low

If the battery charge remaining decreases to a certain level during operation (Low BATT status), a low-battery message, flashing of the tally lamps, and a beep sound will warn you. If the remaining further decreases to a level at which operation cannot be continued (BATT Empty status), a battery-empty message appears. Replace the battery pack with one that is fully charged.

To change the message levels

The “Low BATT” level is set to 10% of full charge, and the “BATT Empty” level is set to 3% of full charge at the factory. These settings can be changed with [Battery Alarm] (*page 57*) in the [OTHERS] menu.

Using AC Power (DC IN Power)

Connection example: when connecting BC-U1

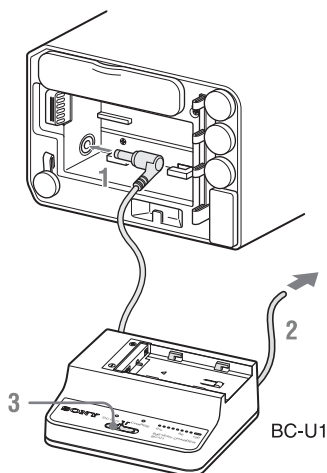

- 1 Connect the DC power output cable of the BC-U1 to the DC IN connector of the recorder.
- 2 Connect the power cord of the BC-U1 to an AC power source.
- 3 Set the mode switch of the BC-U1 to the DC OUT position.

Turning the Power On/Off

To turn on the power supply, press the power button (*page 5*). The power supply lamp lights up. To turn off the power supply, press the power button again.

Notes

- This recorder uses a little standby power even when the power button is set to OFF. Remove the battery pack if the recorder will not be used for a prolonged period.
- When removing the battery pack or the DC IN power, be sure to first set the power button to the OFF position. Removing the battery pack or the DC IN power while the recorder is ON may cause damage to the recorder or the SxS memory card.

Setting the Clock

When you turn the recorder on for the first time after purchasing or replacing the backup battery (*page 83*), the Initial Setting display appears on the LCD monitor.

Time Zone

The value shows the time difference from UTC (Coordinated Universal Time).

Change the setting if needed.

Setting the time and date

Move the cursor, then press the SEL/SET button to set each menu item. When you press the SEL/SET button when the cursor is on [Finish], the Initial Setting display disappears, and the clock setting is completed.

After the Initial Setting display disappears, [Time Zone] (*page 55*) and [Clock Set] (*page 55*) in the [OTHERS] menu can be used to set [Time Zone] and [Date/Time].

Notes

- If the clock setting is cleared because of exhaustion of the backup battery while no operation power was being supplied (no battery pack and no DC IN connection), the Initial Setting display will be displayed when you turn the recorder on at the next opportunity.
- While the Initial Setting display is shown, no other operation except turning the power off is permitted until you finish the setting for this display.

Using SxS Memory Cards

Insert SxS memory cards (not supplied) (herein referred to as memory cards) into the card slots to record video and audio.

For details on other types of media you can use with the recorder, see “Using Other Media” (page 15).

Supported SxS memory cards

Use the following Sony-made memory cards. For details on operations with media from other manufacturers, refer to the operating instructions for the media or consult the manufacturer’s information.

SxS PRO+ series

SxS PRO series

SxS-1 series

SxS PRO and SxS-1 series cards comply with the ExpressCard standard.

Inserting a memory card

- 1 Open the cover of the card slot block.
- 2 Insert the memory card in the card slot with the label facing up, and close the cover.

Cover open

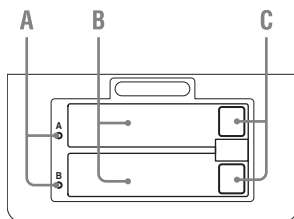

- A. ACCESS lamps
- B. SxS memory card slots
- C. EJECT (SxS memory card) buttons

Status indications by the ACCESS lamps

Lamp	Slot statuses
Lights red	Accessing the loaded memory card (writing/reading data)
Lights green	Standby (ready for recording or playback using the loaded memory card)
Off	<ul style="list-style-type: none"> • No memory card is loaded. • The loaded card is invalid. • A memory card in another slot is active.

Removing a memory card

- 1 Open the cover of the card slot block, press the EJECT button, then pull the button out.
- 2 Press the EJECT button again to remove the card.

Note

Data are not guaranteed if the power is turned off or a memory card is removed while the card is being accessed. All data on the card may be destroyed. Be sure that the ACCESS lamps are lit in green or off when you turn off the power or remove memory cards.

Switching between memory cards

Press the SLOT SELECT button (page 5). If a card becomes full during recording, switching to the other card is automatically executed.

Note

The SLOT SELECT button is disabled while playback is in progress. Switching is not executed even if you press the button. The button is enabled while the thumbnail screen is displayed (page 32).

Formatting a memory card

For a memory card that is not formatted or that was formatted with another system, the message “Unsupported File System” is displayed on the LCD monitor.

Memory cards for use in this recorder should be formatted using this recorder.

To execute formatting

Using [Format Media] (page 60) in the [OTHERS] menu, specify the slot and then select [Execute]. On a confirmation message, select [Execute] again.

When formatting is completed, the completion message is displayed for three seconds.

Recording/playback during formatting

You can perform recording or playback using the memory card in the other card slot while formatting is in progress.

If formatting fails

A write-protected memory card or memory card that cannot be used with this recorder will not be formatted. Replace the card with an appropriate SxS memory card, as per the instructions in the message.

Notes

- All the data, including recorded pictures and setup files, are erased when a memory card is formatted.
- Use only SxS memory cards that were formatted using the recorder's formatting function. Memory cards formatted on other devices will be recognized as a different format, and reformatting on the recorder will be required.

Recorder and computer connection

Connect the recorder to a computer using a USB cable, and insert a memory card recorded on an XDCAM/XDCAM EX series device in the recorder's memory card slot.

Checking the remaining time available for recording

While recording or in standby mode, you can check the time remaining for the memory cards loaded in the card slots on the LCD monitor (*page 9*).

The available time for recording with the current video format (recording bit rate) is displayed in time units of minutes.

The remaining can also be checked in a meter format on the Battery/Media status screen (*page 44*).

Note

A  icon appears if the memory card is write-protected.

Replacing a memory card

- If the available time on two cards in total becomes less than 5 minutes, a message "Media Near Full," flashing of the tally lamps, and a beep sound will warn you. Replace the cards with those with sufficient space.
- If you continue recording until the total remaining time reaches zero, the message changes to "Media Full," and recording stops.

Note

Approximately 600 clips can be recorded on one memory card at maximum.

If the number of recorded clips reaches the limit, the remaining time indication becomes "0," and the message "Media Full" is displayed.

Restoring a memory card

If an error occurs with data in a memory card for some reason, the card must be restored.

If a memory card that needs to be restored is loaded, a message that prompts you to execute a restore operation is displayed on the LCD monitor.

To restore a card

Select "Execute," then push the SEL/SET button. When restoration is completed, the completion message is displayed for three seconds.

If restoration fails

- A write-protected memory card or one on which an error occurred cannot be restored. For such a card, a warning message is displayed. Release the write protection or replace the card, as per the instructions in the message.
- A memory card on which an error occurred may become usable again through repeated formatting.
- In some cases, only parts of clips cannot be restored. Playback of the restored clips becomes possible again.
- The following operation may restore a memory card for which the message "Could not Restore Some Clips" is repeatedly displayed each time you try the restoration process:

- 1 Copy necessary clips to another memory card, using the copy function (*page 39*) of the recorder or the dedicated application software (*page 10*).
- 2 Format the problem memory card, using the format function of this recorder.
- 3 Copy the necessary clips back to the memory card.

Recording/playback during restoration

You can perform recording or playback using the memory card in the other card slot while restoration is in progress.

Note

For restoration of media recorded with this unit, be sure to use this unit. Media recorded with a device other than

this unit or with another unit of different version (even of the same model) may not be restored using this unit.

Using Other Media

You can record video and audio to the following types of media by using a separately supplied adapter.

The high reliability and durability of professional SxS memory cards is not guaranteed.

Supported media

Use the following Sony media.

For details on operations with media from other manufacturers, refer to the operating instructions for the media or consult the manufacturer's information.

XQD memory cards series

SDHC cards (Class 10) series

The optional QDA-EX1 XQD ExpressCard adapter is required to use XQD memory cards. The optional MEAD-SD02 media adapter is required to use SDHC cards. Using these adapters allows the recorder to record and playback in the same way as for an SxS memory card.

For details on operations, see "Using SxS Memory Cards" (page 13).

Notes

- XQD memory cards, and SDHC cards may not operate correctly when using fast forward playback (*page 7*).
- Operation with all memory cards is not guaranteed. Consult your dealer for information about memory cards that have been tested and confirmed to work with the recorder.
- The recorder cannot record in UDF to SDHC cards.

Removing and Attaching the Audio Input Box

The audio input box is removable. You can remove the audio input box when it is not in use.

Note

Turn the recorder off before attaching and removing the audio input box.

Removing the Audio Input Box

- 1 Loosen the four screws (M3) on the audio input box, and lift the box straight up.

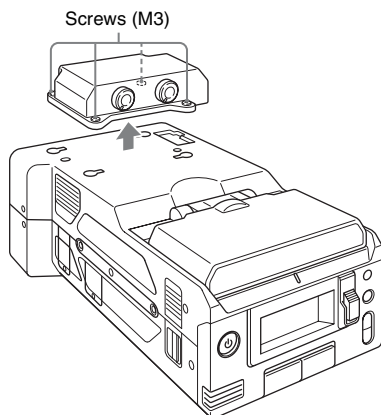

- 2 Remove the covers stored on the bottom of the audio input box, and attach them to the holes on the recorder.

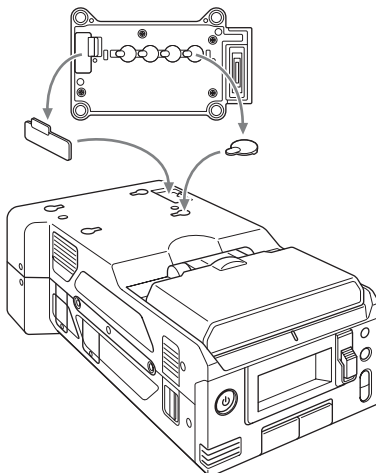

Tip

Pressing the area in the illustration will make removing the covers for the screw holes easier.

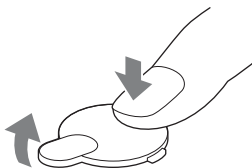

Attaching the Audio Input Box

- 1 Remove the covers attached to the recorder, and attach them to the bottom of the audio input box.

Be sure to store the removed covers on the bottom of the audio input box to prevent losing them.

- 2 Place the audio input box on the recorder, and secure the four screws (M3).

Align the two guides on the bottom of the audio input box with the holes on the recorder, and place it directly on the recorder. There are also position alignment guide lines on the front of the recorder and front of the audio input box. Position the audio input box so that the two guide lines align.

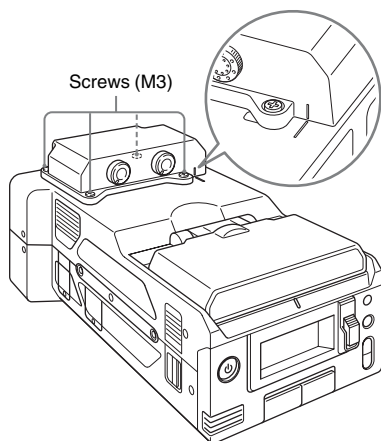
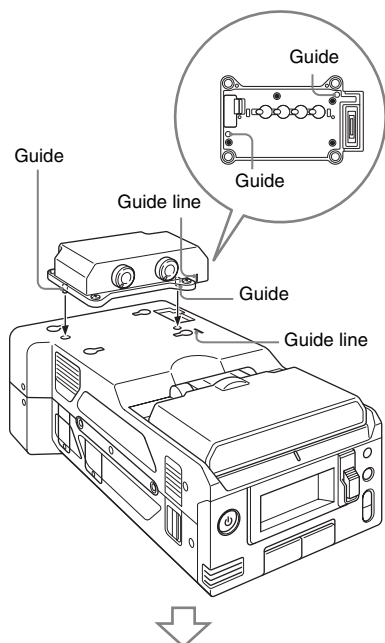

Using a Wi-Fi Connection

The recorder can connect to a computer, smartphone, or tablet via Wi-Fi by attaching an optional Wi-Fi adapter on the recorder. The following Wi-Fi adapters are supported.

- CBK-WA100 Wireless Adapter
- IFU-WLM3 Wireless LAN USB Module

For details on the Wi-Fi connection method for the CBK-WA100, refer to the operating instructions for the CBK-WA100.

Making a Wi-Fi connection between a computer, smartphone, or tablet and the recorder enables you to do the following.

- Send planning metadata created on a computer to the recorder, and set names of clips and shot marks.
- Display the Wi-Fi remote controller on a computer, smartphone, or tablet to control the recorder remotely.

Notes

- Do not connect devices other than those specified to the external device connector.
- Always turn off the power supply before attaching or removing a CBK-WA100 or IFU-WLM3.
- When using the CBK-WA100, you cannot use the IFU-WLM3.
- An i.LINK connection and USB wireless LAN module cannot be used at the same time. When using a wireless connection with an IFU-WLM3 inserted directly into the external device connector, do not connect a device to the i.LINK connector.
- The IFU-WLM3 USB Wireless LAN Module (sold separately) may not be available in some countries/regions.
- Using other wireless devices near the recorder may result in improper operation of the recorder. Turn off wireless devices near the recorder whenever possible.

Attaching the CBK-WA100

- 1 Remove the top part of the bracket, and secure the main part of the bracket to the CBK-WA100 using the three screws (M2×5) supplied with the CBK-WA100.

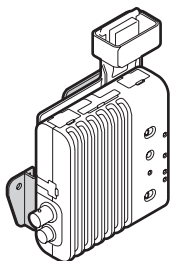
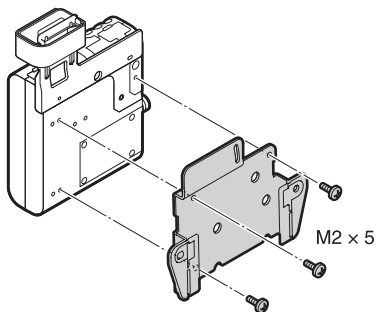
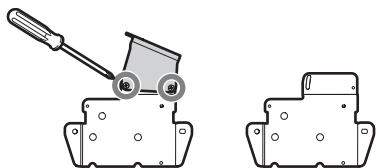

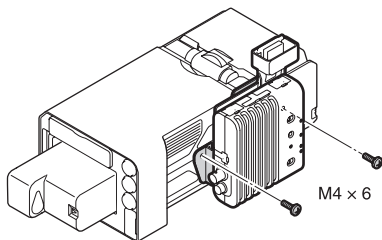

- 2** Secure the CBK-WA100 to the recorder using the two screws (M4×6) supplied with the CBK-WA100.



- 3** Use the USB cable supplied with the CBK-WA100 to connect the external device connector (page 6) on the

recorder to the Mini USB connector on the CBK-WA100.

- 4** Use the BNC cable supplied with the CBK-WA100 to connect the SDI OUT 1/2 connector (page 6) on the recorder to the SDI IN connector on the CBK-WA100.
- 5** When supplying power to the CBK-WA100 from the recorder, use the DC power supply cable supplied with the CBK-WA100 to connect the DC OUT connector (page 6) on the recorder to the  (DC IN) connector on the CBK-WA100.

When using a separately supplied AC adapter, connect it to the  (DC IN) connector on the CBK-WA100.

Note

Power can only be supplied to an external device from either the DC OUT connector or the external device connector. They cannot both be used to supply power at the same time.

Connecting to Wi-Fi with the CBK-WA100

- 1 Turn on the recorder.
- 2 When supplying power to the CBK-WA100 from the recorder, set [OTHERS] > [Power Enable] in the setup menu to [Sony Wireless Adapter].
The recorder will restart after you change the setting.
- 3 Set the output signal from the SDI OUT connector that is connected to the CBK-WA100 to [SD] or [HD] in the [VIDEO SET] > [SDI/HDMI/i.LINK I/O Select] setup menu.
- 4 Turn on the CBK-WA100.

Using the Web Menu

You can operate the Web menu built in the recorder from a computer when it is connected to the recorder via a Wi-Fi connection.

Configuring the recorder

- 1 Set [OTHERS]>[Wi-Fi]>[Wi-Fi] in the setup menu to [Enable].
- 2 Set [OTHERS]>[Wi-Fi]>[Wi-Fi Remote] in the setup menu to [On].

Configuring the device

Configure the smartphone, tablet, computer, or other device.

- 1 Connect the recorder and device via Wi-Fi.

For details about connecting the CBK-WA100 and IFU-WLM3 via Wi-Fi, refer to the operating instructions for each device.

- 2 Launch a browser on the device and access the “[http://recorder IP address \(\[OTHERS\] >\[Network\] >\[IP Address\]\)/rm.html](http://recorder IP address ([OTHERS] >[Network] >[IP Address])/rm.html)” URL.

Example; Enter “<http://192.168.1.10/rm.html>” in the address bar if the IP address is 192.168.1.10.

The [Wi-Fi Remote] screen appears on the device when successfully connected.

Thereafter, operate the recorder using the controls on the screen.

Sliding the Lock knob to the right allows you to prohibit REC button operation.

Notes

- To display the page designed for smartphones, enter a URL ending in “rms.html.” To display the page designed for tablets, enter a URL ending in “rmt.html.” Normally, entering a URL ending in “rm.html” automatically displays each page. Note that the controller may not operate correctly on some devices.
- The recorder status may not match the [Wi-Fi Remote] screen under the following circumstances. If this occurs, refresh the browser display.
 - When the recorder is restarted during a connection
 - When the recorder is operated during a connection
 - When the device is reconnected
 - When the Back/Next buttons in the browser are used
- Wi-Fi Remote may not function if the wireless status (signal strength) deteriorates significantly.
- Some smartphones and tablet devices may not be equipped with ad-hoc mode support. For details, refer to the operating instructions for your smartphone or tablet.

Supported devices

The following devices, OS, and browsers (and later versions) support Wi-Fi remote control operation.

Device	OS	Browser
PC	Windows 7 SP1	Internet Explorer 11
	Windows 8.1	Internet Explorer 11
Mac	OS 10.7	Safari
	OS 10.8	
Smartphone	Android 4.1, 4.2, 4.3	Chrome
	iOS 6, 7	Safari
Tablets	Android 4.1, 4.2, 4.3	Chrome
	iOS 6, 7	Safari

Changing Basic Settings

Selecting an Input Signal

To record or output a signal, either SDI or i.LINK must be selected as the input signal source. The setting is made in [Input Source Select] in the [VIDEO SET] menu.

If i.LINK is selected, output to i.LINK is not possible.

In UDF/HD mode and exFAT mode, i.LINK cannot be selected.

Video Formats

Switching between UDF/exFAT/FAT

Switch by setting [F.Sys.] under [System] (page 57) in the [OTHERS] menu.

After switching this setting, the recorder will automatically restart.

Switching between HD Mode/SD Mode

For [HD/SD] switching, use [System] (page 57) in the [OTHERS] menu.

When you change the menu setting, the recorder automatically restarts, executing the switching.

Note

[UDF/exFAT/FAT] and [HD/SD] switching is disabled during recording and playback.

Switching between XAVC/MPEG2

Switch by setting [XAVC/MPEG2] under [System] (page 57) in the [OTHERS] menu. This can be selected when [F.Sys.] is set to [exFAT] and [HD/SD] is set to [HD].

Note

You cannot switch between XAVC/MPEG2 during recording or playback.

Changing the format

The format of the input signal connected to the SDI IN connector must match the video format set in [Rec Format] (page 58) in the [OTHERS] menu.

The format of the signals output from the SDI OUT 1/2, VIDEO OUT, and HDMI OUT connectors changes according to the video format setting.

Selectable formats vary depending on the UDF/exFAT/FAT, HD/SD, and usage region (NTSC/PAL) settings (page 57).

The supported video format settings and corresponding supported input formats are shown below.

For details about the output signal format, see “Formats and Limitations of Outputs” (page 76).

For NTSC

UDF/HD mode

[Rec Format] setting	Input signal format
HD422 50/1080/59.94i	1080/59.94i, 1080/29.97PsF
HQ 1920×1080/59.94i	1080/59.94i, 1080/29.97PsF
HQ 1440×1080/59.94i	1080/59.94i, 1080/29.97PsF
HD422 50/1080/29.97P	1080/59.94i, 1080/29.97PsF
HQ 1920×1080/29.97P	1080/59.94i, 1080/29.97PsF
HQ 1440×1080/29.97P	1080/59.94i, 1080/29.97PsF
HD422 50/1080/23.98P	1080/23.98PsF
HQ 1920×1080/23.98P	1080/23.98PsF
HQ 1440×1080/23.98P	1080/23.98PsF
HD422 50/720/59.94P	720/59.94P
HQ 1280×720/59.94P	720/59.94P

exFAT/HD mode

[Rec Format] setting	Input signal format
XAVC-I 1080/59.94P	1080/59.94P
XAVC-L50 1080/59.94P	1080/59.94P
XAVC-L35 1080/59.94P	1080/59.94P
XAVC-I 1080/59.94i	1080/59.94i, 1080/29.97PsF
XAVC-L50 1080/59.94i	1080/59.94i, 1080/29.97PsF
XAVC-L35 1080/59.94i	1080/59.94i, 1080/29.97PsF
XAVC-L25 1080/59.94i	1080/59.94i, 1080/29.97PsF

[Rec Format] setting	Input signal format
XAVC-I 1080/29.97P	1080/59.94i, 1080/29.97PsF
XAVC-L50 1080/29.97P	1080/59.94i, 1080/29.97PsF
XAVC-L35 1080/29.97P	1080/59.94i, 1080/29.97PsF
XAVC-I 1080/23.98P	1080/23.98PsF
XAVC-L50 1080/23.98P	1080/23.98PsF
XAVC-L35 1080/23.98P	1080/23.98PsF
XAVC-I 720/59.94P	720/59.94P
XVAC-L50 720/59.94P	720/59.94P
HD422 50/1080/59.94i	1080/59.94i, 1080/29.97PsF
HQ 1920×1080/59.94i	1080/59.94i, 1080/29.97PsF
HQ 1440×1080/59.94i	1080/59.94i, 1080/29.97PsF
HD422 50/1080/29.97P	1080/59.94i, 1080/29.97PsF
HQ 1920×1080/29.97P	1080/59.94i, 1080/29.97PsF
HQ 1440×1080/29.97P	1080/59.94i, 1080/29.97PsF
HD422 50/1080/23.98P	1080/23.98PsF
HQ 1920×1080/23.98P	1080/23.98PsF
HQ 1440×1080/23.98P	1080/23.98PsF
HD422 50/720/59.94P	720/59.94P
HQ 1280×720/59.94P	720/59.94P

FAT/HD mode

[Rec Format] setting	Input signal format
HQ 1920×1080/59.94i	1080/59.94i, 1080/29.97PsF
HQ 1440×1080/59.94i	1080/59.94i, 1080/29.97PsF
SP 1440×1080/59.94i	1080/59.94i, 1080/29.97PsF
HQ 1920×1080/29.97P	1080/59.94i, 1080/29.97PsF
HQ 1440×1080/29.97P	1080/59.94i, 1080/29.97PsF
HQ 1920×1080/23.98P	1080/23.98PsF
HQ 1440×1080/23.98P	1080/23.98PsF
HQ 1280×720/59.94P	720/59.94P

UDF/SD mode

[Rec Format] setting	Input signal format
DVCAM 59.94i	480/59.94i
IMX50 59.94i	486/59.94i

exFAT/SD mode

[Rec Format] setting	Input signal format
DVCAM 59.94i	480/59.94i
IMX50 59.94i	486/59.94i

FAT/SD mode

[Rec Format] setting	Input signal format
DVCAM 59.94i	480/59.94i

For PAL

UDF/HD mode

[Rec Format] setting	Input signal format
HD422 50/1080/50i	1080/50i, 1080/25PsF
HQ 1920×1080/50i	1080/50i, 1080/25PsF
HQ 1440×1080/50i	1080/50i, 1080/25PsF
HD422 50/1080/25P	1080/50i, 1080/25PsF
HQ 1920×1080/25P	1080/50i, 1080/25PsF
HQ 1440×1080/25P	1080/50i, 1080/25PsF
HD422 50/720/50P	720/50P
HQ 1280×720/50P	720/50P

exFAT/HD mode

[Rec Format] setting	Input signal format
XAVC-I 1080/50P	1080/50P
XAVC-L50 1080/50P	1080/50P
XAVC-L35 1080/50P	1080/50P
XAVC-I 1080/50i	1080/50i, 1080/25PsF
XAVC-L50 1080/50i	1080/50i, 1080/25PsF
XAVC-L35 1080/50i	1080/50i, 1080/25PsF
XAVC-L25 1080/50i	1080/50i, 1080/25PsF
XAVC-I 1080/25P	1080/50i, 1080/25PsF
XAVC-L50 1080/25P	1080/50i, 1080/25PsF
XAVC-L35 1080/25P	1080/50i, 1080/25PsF
XAVC-I 720/50P	720/50P
XAVC-L50 720/50P	720/50P
HD422 50/1080/50i	1080/50i, 1080/25PsF
HQ 1920×1080/50i	1080/50i, 1080/25PsF
HQ 1440×1080/50i	1080/50i, 1080/25PsF
HD422 50/1080/25P	1080/50i, 1080/25PsF
HQ 1920×1080/25P	1080/50i, 1080/25PsF
HQ 1440×1080/25P	1080/50i, 1080/25PsF
HD422 50/720/50P	720/50P
HQ 1280×720/50P	720/50P

FAT/HD mode

[Rec Format] setting	Input signal format
HQ 1920×1080/50i	1080/50i, 1080/25PsF
HQ 1440×1080/50i	1080/50i, 1080/25PsF
SP 1440×1080/50i	1080/50i, 1080/25PsF
HQ 1920×1080/25P	1080/50i, 1080/25PsF
HQ 1440×1080/25P	1080/50i, 1080/25PsF
HQ 1280×720/50P	720/50P

UDF/SD mode

[Rec Format] setting	Input signal format
DVCAM 50i	576/50i
IMX50 50i	576/50i

exFAT/SD mode

[Rec Format] setting	Input signal format
DVCAM 50i	576/50i
IMX50 50i	576/50i

FAT/SD mode

[Rec Format] setting	Input signal format
DVCAM 50i	576/50i

Time Data

Setting the Timecode

Specify the timecode to be recorded with [Timecode] and [TC Format] in the [TC/UB SET] menu (*page 53*). The following methods are available for recording the timecode.

Preset mode (Preset)

Records an internally generated timecode with a preset initial value. You can select one of the following run modes.

- **Free Run:** Timecode is always running.
- **Rec Run:** Timecode runs only when recording.

Regeneration mode (Regen)

Records an internally generated timecode that continues from the timecode of the last recorded clip.

External regeneration mode (ExtRegen)

Records an internally generated timecode that is synchronized to the timecode superimposed on an external input signal. If a timecode is not superimposed on an input SDI signal, the value of the internal timecode generator is used as the initial value.

Setting the Users Bit

You can add a hexadecimal number of 8 digits for pictures as the user bits.

The user bits can also be set to the current date. Use [Users Bit] (*page 53*) in the [TC/UB SET] menu.

Displaying the Time Data

Pressing the DISPLAY button displays the time data on the screen (*page 9*). The indication is switched among the timecode, user bits, and recording duration by pressing the DURATION/TC/U-BIT button (*page 6*).

Display	Contents
TCG **.*:***:**	Timecode
TCR **.*:***:**	Timecode superimposed on the input signal
CLK **.*:***:**	Timecode (Clock mode)
UBG ** ** ** ** ** **	User bits
UGR ** ** ** **^	User bits superimposed on the input signal
DUR **.*:***:**	Duration from the beginning of recording

Setting the Output Mode

The output mode of the video signal output on the SDI OUT 1 connector can be selected when editing while simultaneously outputting video.

The setting is made in [SDI OUT1 Mode Select] of the [VIDEO SET] menu. The image on the LCD monitor is output from the SDI OUT 2, HDMI, VIDEO OUT, and i.LINK connectors. **[Normal] mode:** The same video as that displayed on the LCD monitor is output.

[Through] mode: The SDI IN input signal is always output, regardless of the operating state.

[Auto] mode: The playback video is output during playback operations on the recorder (PLAY/PAUSE, F FWD, F REV). In all other cases, the SDI IN input signal is output.

In Auto mode, [SDI/HDMI/Video Out Super] (*page 51*) in the [VIDEO SET] menu is set to [Off], and no character information is output.

Recording

Note

Using mobile phones and wireless devices near the recorder may result in recording and playback stops due to frequency and power outputs. Use such devices at a distance that does not affect the recorder.

1 Select the input signal to record in [Input Source Select] in the [VIDEO SET] menu.

2 Press and hold the REC button, then press the PLAY/PAUSE.

The “●REC” indication flashes if normal recording does not occur, for example, if the specified video format is different to the input signal format or if there is no input signal.

To stop recording

Press the STOP/EE button.

Recording stops, and the recorder switches to E-E mode.

To delete clips

You can delete the last recorded clip by using the [Last Clip DEL] function (*page 27*). Use the [All Clips DEL] function (*page 27*) to delete all recorded clips from an SxS memory card. To specify a clip to be deleted, operate the recorder from the thumbnail screen (*page 32*).

Clip (recording data)

When you stop recording, video, audio and subsidiary data from the start to end of the recording are recorded as a single clip on an SxS memory card.

Clip name

For each clip recorded with this recorder, a clip name is automatically generated according to the method selected with [Auto Naming] in [Clip] (*page 59*) in the [OTHERS] menu.

The default setting of [Auto Naming] is [Plan]. With this setting, a clip name defined in planning metadata is applied if a planning metadata file is loaded into the recorder.

Change the [Auto Naming] setting to [Title] to apply a clip name composed of 4 to 46 alphanumeric and 4 numerics.

Example: ABCD0001

The block of 4 to 46 alphanumeric can be specified as desired using [Clip] in the [OTHERS] menu before you start recording. (It cannot be changed after recording.)

The value of the 4 numerics is automatically counted up in sequence.

Notes on Clips

The maximum file size for a clip is 43 GB for UDF and exFAT modes, 4 GB for FAT/HD mode, and 2 GB for FAT/SD mode.

If you record continuously for an extended period, the recorded material may be split into multiple files due to file size restrictions (up to 99 separate files).

In FAT mode, material that was split into multiple files will still be treated as a single clip by the recorder.

A long clip can be recorded crossing over two memory cards in slot A and B.

When you copy recorded clips to a hard disk drive, etc. using a computer, it is recommended to download and use the dedicated application software (*page 10*).

Note

If copying is done using “Explorer” (Windows) or “Finder” (MAC), the continuity and relationships of recorded materials may not be maintained.

Maximum duration of a clip

The maximum clip length is 24 hours for FAT (MP4 or AVI) and 6 hours for UDF (MXF) and exFAT (MXF).

If you exceed the maximum clip length, a new clip will be automatically created. You can check the new clip on the thumbnail screen.

Useful Functions

Color Bars/Reference Tone

By setting [Color Bars On/Off] (*page 49*) in the [VIDEO SET] menu to [On], you can output a color-bar signal in place of the camera picture. When this item is set to [Off], the output returns to the camera picture.

A 1 kHz reference tone is output with the color bar signal if [1KHz Tone] in [Audio Output] (*page 49*) in the [AUDIO SET] menu is set to [On].

The color-bar signal and reference-tone signal are also fed out from the SDI OUT 1/2, HDMI OUT, i.LINK, VIDEO OUT (color bars only), and AUDIO OUT connectors (reference audio signal only).

You can select the type of color bars with [Color Bars Type] in the [VIDEO SET] menu.

Shot Marks **UDF** **exFAT** **FAT/HD**

Shot marks can be recorded at important audio/video scenes for clips recorded in UDF, exFAT or FAT/HD mode. Using shot marks enables the target scenes to be quickly and easily cued up on the Shot Mark screen (*page 41*).

The recorder permits you to record two types of shot marks: shot mark 1 and shot mark 2.

Shot marks can be inserted as needed during recording or can be added after recording while checking the playback pictures on the thumbnail screen.

The recorder can use shot mark 1 and shot mark 2 as the in-point and out-point, respectively, for in-point to out-point partial playback (*page 34*).

Inserting a shot mark during recording

Assign [Shot Mark1] and [Shot Mark2] to the assignable buttons (*page 26*), and press the buttons at the scenes you want the shot marks inserted during recording.

Inserting a shot mark during playback

Press the assignable buttons to which [Shot Mark1] and [Shot Mark2] are assigned at the scenes you want the shot marks inserted during clip playback.

Note

Shot marks cannot be recorded onto write-protected SxS memory cards. Also, shot marks cannot be inserted at the start or end of a clip.

Shot marks can also be added and deleted using the Shot Mark screen (*page 41*).

For operation to apply a name to a shot mark, see “Defining Shot Mark names in Planning Metadata” on page 30.

OK/NG/KP Flags **UDF** **exFAT**

You can add OK/NG/KP flags to clips recorded with UDF or exFAT. By adding flags, you can set the recorder to display only clips with certain flag settings on the thumbnail screen (OK/NG/KP/None-Clip thumbnail screen) (*page 33*).

Note

Use the [Lock Clip] setting (*page 37*) to protect clips.

Adding a flag

During recording or playback, press the assignable button to which you assigned the [Clip Flag OK/Clip Flag NG/Clip Flag Keep] function.

Deleting a flag

Press the assignable button, twice in succession, to which you assigned the [Clip Flag OK/Clip Flag NG/Clip Flag Keep] function.

*OK/NG/KP flags can also be added and deleted from the thumbnail screen. For details, see “OK/NG/KP Flag” (*page 38*).*

OK Mark **FAT/HD**

By adding the OK mark to a clip recorded in FAT/HD Mode, you can prevent the clip from being deleted or divided inadvertently. You can also set the recorder to display only clips with the OK mark on the thumbnail screen (OK-Clip thumbnail screen) (*page 33*).

Adding the OK mark

When recording of a clip ends, press the assignable button to which you assigned the [OK Mark] function.

While standing by to record, you can also add an OK mark to the last-recorded clip ([Last Clip]) on the selected memory card.

Deleting the OK mark

Press the assignable button to which you assigned the [OK Mark] function, and select [Execute]. While standing by to record, you can also delete the OK mark from the clip with the last-added OK mark.

Adding or deleting the OK mark to or from clips before the last one

Make changes via the thumbnail screen (*page 39*).

Assignable Buttons

The recorder has five assignable buttons (*page 7*) to which you can assign various functions for convenience.

To change functions

Use [Assign Button] (*page 56*) in the [OTHERS] menu.

The assigned functions can be viewed on the Button/Remote status screen (*page 44*).

Clip Continuous Recording

UDF **exFAT**

Clips are normally created individually for each time you start and stop recording, but you can also continue recording to a single clip regardless of the number of times you start and stop recording by using the Clip Continuous Recording function, which will add recordings to the same clip until the function is disabled or turned off.

This is convenient for when you do not want to create a large number of short clips, or when you do not want to be restricted by a maximum number of clips.

A recording start mark is added to each point at which you resume recording, making it easy to search for each point.

Preparatory settings

Set [Clip Cont. Rec Setting] (*page 51*) in the [VIDEO SET] menu to [On].

When you set [Setting] to [On] the [Clip Continuous Recording] function is enabled, and “CONT” appears on the screen (*page 9*).

You can also assign [Clip Continuous Rec] to an assignable button (*page 26*), and set to [On]/[Off] by pressing the button.

Notes

- Clip Continuous Recording cannot be used while recording.
- This function cannot be used with FAT.

Performing clip continuous recording

Press and hold the REC button, then press the PLAY/PAUSE.

When recording starts, the “CONT” indication on the screen changes to “●REC” (with ● in red).

To pause recording, press the PLAY/PAUSE button. To resume, press and hold the REC button, then press the PLAY/PAUSE button.

Pressing the STOP/EE button closes the clip. In clip continuous mode, the “CONT” indicator flashes if there is no continuous clip.

When operating the IR Remote Commander, press the START/STOP button to start recording, and press the START/STOP button or PAUSE button to stop recording. To resume, press the START/STOP button again. Pressing the STOP button will close the clip.

Notes

- If you remove the SxS memory card or the battery while recording or standing by to record (the “CONT” indication appears), the SxS memory card must be restored. Only remove the SxS memory card after Clip Continuous Recording is complete. If “CONT” is flashing (1 time per second), you can remove the SxS memory card.
- Record for at least 2 seconds before you stop recording.
- If [Input Source Select] is set to [i.LINK], the [Clip Continuous Recording] function is disabled.

To disable Clip Continuous Recording mode

While standing by to record, set [Clip Cont. Rec Setting] (*page 51*) in the [VIDEO SET] menu to [Off].

Restricted operations

If you perform any of the following operations while recording or standing by to record, 1 continuous clip will not be created. The next time you start recording, a new clip will be created.

- Performing clip operations (locking, deleting, or changing the names of clips).
- Switching the memory card slot.
- Changing the recording format.
- Setting the power button to OFF.
- Displaying the thumbnail screen.
- Playing clips.

Loop Recording **UDF** **exFAT**

You can continue recording video for a fixed interval by alternately recording and deleting video using two SxS memory cards.

Preparatory settings

Set [Segment Loop Rec] (*page 51*) in the [VIDEO SET] menu to [On]. Loop recording is enabled, and “SL-REC” appears on the screen (*page 9*).

Set the recording retention time in [Segment Duration].

In loop recording, the recording time that is retained of a clip varies depending on the recording status of the memory card when recording was stopped. When [15~35min] is selected in [Segment Duration], a minimum of 15 minutes and a maximum of 35 minutes is retained. When [15~35min] is selected, a minimum of 25 minutes free capacity is required on each SxS memory card. When [30~65min] is selected, a minimum of 40 minutes free capacity is required.

Notes

- Use SxS memory cards for loop recording. Recording to other memory cards using a media adapter is not supported.
- Loop recording is not supported in FAT mode.

Starting loop recording

Press and hold the REC button, and press the PLAY/PAUSE button.

Recording starts and “●REC” appears on the screen.

Pressing the STOP/EE button stops recording and closes the clip. Simultaneously, the [Segment Loop Rec] setting is set to [Off].

If the REC button and PLAY/PAUSE button are pressed simultaneously during loop recording, the recorder switches to normal recording and continues recording the clip seamlessly. After switching, the “SL-REC” indication on the screen disappears.

Notes

- In loop recording, video on the SxS memory cards is repeatedly recorded and deleted, shortening the rewrite life of the cards. Accordingly, check the remaining life of the memory cards periodically.
- If using loop recording continuously for longer than one week, restart the recorder once per week. Also, if

the loop stops operating or other abnormality appears during operation, restart the recorder.

Restricted operations

If you perform any of the following operations while loop recording, the recorder will switch to normal recording and the [Segment Loop Rec] setting will be set to [Off] automatically.

- Switching the memory card slot
- Ejecting media that is not recording

Deleting Clips

While standing by to record, the [Last Clip DEL] function for deleting the last recorded clip and the [All Clips DEL] function for deleting all clips from an SxS memory card are available.

For clip deletion on the thumbnail screen, see “Deleting Clips” on page 39.

To delete using the assignable button

Assign the [Last Clip DEL] function to one of the assignable buttons (*page 26*) in advance.

Press the assignable button to which you have assigned [Last Clip DEL], and select [Execute] to delete the last recorded clip from the SxS memory card.

To delete using the Setup menu

Select [Last Clip DEL] in [Clip] (*page 59*) in the [OTHERS] menu, select [Execute], then select [Execute] again to delete the last recorded clip from the SxS memory card.

Note

When Clip Continuous Recording is set to [On], [Last Clip DEL] cannot be selected.

Deleting clips collectively

Select [All Clips DEL] in [Clip] (*page 59*) in the [OTHERS] menu, select [Execute], then select [Execute] again to delete all the clips from the SxS memory card.

Notes

- If the SxS memory card contains clips of both of HD Mode and SD Mode, only the clips of the currently selected mode are deleted.
- Clips with the OK mark (*page 25*) cannot be deleted in FAT mode. In UDF or exFAT mode, clips set to [Lock Clip] (*page 37*) cannot be deleted.

Storing/Retrieving the Setting Data

You can store all the menu settings as a setup file on an SxS memory card or a USB flash drive. By retrieving the stored setup file, the proper setup condition can be immediately obtained.

Note

Values for [Clock Set] and [Hours Meter] in the [OTHERS] menu are not stored.

Storing the Setup file

To use an SxS memory card

Only one setup file—designated with the file name “SETUP.SUF”—can be stored on one SxS memory card.

- 1 Insert a memory card on which you wish to store the setup file to a card slot.**
Check that the inserted card is selected.
- 2 Select [Store(SxS)] in [Setup Data] (page 55) in the [OTHERS] menu, then select [Execute].**

Note

If a setup file already exists on the memory card you specified in Step 1, a message to confirm whether to overwrite the file is displayed.

To use a USB flash drive **UDF** **exFAT**

Connect the formatted USB flash drive to the external device connector.
Select [Store(USB)] > [Execute] in step 2.

Retrieving the Setup file

To use an SxS memory card

When you retrieve the stored setup file, the recorder settings are changed according to the file.

- 1 Insert the memory card on which you stored the setup file into a card slot.**
Check that the inserted card is selected.
- 2 Select [Recall(SxS)] in [Setup Data] (page 55) in the [OTHERS] menu, then select [Execute].**

To use a USB flash drive **UDF** **exFAT**

Connect the formatted USB flash drive to the external device connector.
Select [Recall(USB)] > [Execute] in step 2.

Resetting to the standard values

The current recorder settings you made through various menu and button operations can be collectively returned to the standard statuses (factory settings) by executing [All Reset] in the [OTHERS] menu.

Planning Metadata

Planning metadata is information about shooting and recording plans, recorded in an XML file. You can shoot using clip names and shot mark names defined in advance in a planning metadata file.

This recorder can display clip names and shot mark names defined in the following languages:

English/Chinese/German/French/Italian/
Spanish/Dutch/Portuguese/Swedish/
Norwegian/Danish/Finnish

Notes

- If you define clip and shot mark names in languages other than those listed above, they may not be displayed on the LCD monitor.
- If you define clip and shot mark names in French, Dutch, or Finnish, some characters are displayed in a different but similar font.

Loading a Planning Metadata file

To record planning metadata together with clips, it is necessary to load a planning metadata file into the recorder's memory in advance.

To use an SxS memory card

Insert the SxS memory card with the planning metadata file (.xml) saved to the directory below into the recorder's card slot, then select and load the file via [Load / Slot(A)] or [Load / Slot(B)] in [Plan.Metadata] (page 60) in the [OTHERS] menu.

UDF: General/Sony/Planning

exFAT: XDROOT/General/Sony/Planning

FAT: BPAV/General/Sony/Planning

To use a USB flash drive **UDF** **exFAT**

Be sure to select [USB A] for [Power Enable] (page 61) in the [OTHERS] menu beforehand.

Notes

Proper operation may not be possible if the USB flash drive is connected without selecting [USB A].

1 Connect a USB flash drive formatted in the FAT32 file system to the external device connector.

A file list appears.

Note

The file list displays up to 64 files. Even if the total number of planning metadata files is 64 or less, all of the planning metadata files may not appear if the directory where they are located on the USB flash drive (General/Sony/Planning) contains 512 or more files.

2 Select the file which you want to load in the file list, then press the SEL/SET button.

Confirming the detailed information in planning metadata

After loading a planning metadata file into memory of the recorder, you can check the details of the file, such as the filename, time and date of file creation, and the titles specified in the file. Select [Properties] in [Plan.Metadata] (page 60) in the [OTHERS] menu, then select [Execute].

Using the Wi-Fi connection

When connecting the unit with a computer via Wi-Fi, the file transmission can be done accessing the unit's Web menu from a computer.

1 Launch the browser and input `http://<recorder's IP address>` (page 61) in the address bar.

2 Input the user name and password, then click [OK].

User name: admin

Password: pmw-rx50

Clearing the loaded planning metadata

To clear the planning data loaded in the recorder's memory, proceed as follows:

Select [Clear] > [Execute] in [Plan.Metadata] (page 60) in the [OTHERS] menu.

Defining a clip name in Planning Metadata

The following two types of clip name strings can be written in a planning metadata file.

- ASCII-format name, which is displayed on the LCD monitor
- UTF-8-format name, which is actually registered as the clip name

You can select the type for displaying the clip name with [Clip Name Disp] in [Plan.Metadata] (page 60) in the [OTHERS] menu.

When you specify a clip name in planning metadata, the name is displayed under the operation status indication on the LCD monitor.

Example of clip name strings

Use a text editor to modify the description for the <Title> tag.

The shaded fields in the example are clip name strings. "Typhoon" is described in ASCII format (up to 44 characters).

"Typhoon_Strikes_Tokyo" is described in UTF-8 format (up to 44 bytes).

Here, "sp" indicates a space, and ↵ indicates a carriage return.

```
<?xmlspversion="1.0"spencoding="UTF-8"?>↵
<PlanningMetadataspxmlns="http://xmlns.sony.net/pro/metadata/planningmetadata"spassignId="P0001"spcreationDate="2011-08-20T17:00:00+09:00"splastUpdate="2011-09-28T10:30:00+09:00"spversion="1.00">↵
  <PropertiessppropertyId="assignment"spupdate="2011-09-28T10:30:00+09:00"spmodifiedBy="Chris">↵
    <TitlespusAscii="Typhoon"spxml:lang="en">Typhoon_Strikes_Tokyo
  </Title>↵
</Properties>↵
</PlanningMetadata>↵
```

Notes

- When you create a file, enter each statement as a single line by breaking a line with a CRLF only after the last character of the line, and do not enter spaces except where specified with "sp."

- A string of up to 44 bytes (or 44 characters) is valid as a clip name. If a UTF-8-format string exceeds 44 bytes, the string up to the 44th byte is used as the clip name. If only a string in ASCII format is specified, the ASCII-format name up to the 44th characters is used as the clip name. When neither the ASCII-format name string nor UTF-8-format name string is valid, a clip name in the standard format is used.

Using a clip name defined in planning metadata

Load a planning metadata file that contains the clip name into memory of the recorder, then select [Plan] in [Auto Naming] in [Clip] (page 59) in the [OTHERS] menu.

Clip names are generated by adding an underscore (_) and a 5-digit serial number (00001 to 99999).

Example: Typhoon_Strikes_Tokyo_00001,
Typhoon_Strikes_Tokyo_00002, ...

Notes

- If the serial number reaches 99999, it returns to 00001 upon the next recording.
- When you load another planning metadata file, the 5-digit serial number returns to 00001.

Defining Shot Mark names in Planning Metadata

When you record shot mark 1 or shot mark 2, you can apply a name to the shot mark, using a string defined in planning metadata.

Example of shot mark name strings

Use a text editor to modify the description for the <Meta name> tag.

The shaded fields in the example are shot mark name strings.

Names can be either in ASCII format (up to 32 characters) or UTF-8 format (up to 16 characters). Here, “sp” indicates a space and ↵ indicates a carriage return.

Note

If a name string contains even one non-ASCII character, the maximum length of that string is limited to 16 characters.

```
<?xmlspversion="1.0"spencoding="
UTF-8"?>↵
<PlanningMetadata xmlns="http://
xmlns.sony.net/pro/metadata/
planningmetadata"sppassId="
H00123"spcreationDate="
2011-04-15T08:00:00Z"splastUpdate="
2011-04-15T15:00:00Z"spversion=
"1.00">↵
```

```
<PropertiessppropertyId=
"assignment"spclass="original"sp
update="2011-04-15T15:00:00Z"sp
modifiedBy="Chris">↵
<TitlespusAscii="Football
Game"spxml:lang="en">
Football Game 15/04/2011
</Title>↵
<Metaspname="_ShotMark1"sp
content="Goal"/>↵
<Metaspname="_ShotMark2"sp
content="Shoot"/>↵
</Properties>↵
</PlanningMetadata>↵
```

Note

When you create a file, enter each statement as a single line by breaking a line with a CRLF only after the last character of the line, and do not enter spaces except where specified with “sp,” except within shot mark name strings.

Copying Planning Metadata files collectively

You can copy planning metadata files stored in the “General” folder on an SxS memory card collectively to another SxS memory card. Select [General Files] in [Copy All] (page 60) in the [OTHERS] menu.

USB flash drives

The following Sony USB flash drives are recommended for use with this recorder.

Pocket Bit Hi-Speed Q Series and M Series

Notes

- Use USB flash drives with a capacity of 4 GB to 32 GB.
- USB flash drives other than those listed above may not be recognized if connected to the external device connector.

To format a USB flash drive

USB flash drives must be formatted with the FAT32 file system.

1 Connect the USB flash drive to the external device connector.

If the drive is unformatted or is formatted in an unsupported format, a message to confirm whether formatting is to be executed appears on the LCD monitor.

2 **Select [Execute], then press the SEL/SET button.**

When formatting is completed, the message “Format USB Memory Done” is displayed.

The

“\MSSONY\PRO\XDCAM\MEMDISC” folder and “\General\Sony\Planning” folder are automatically created in the drive.

To restore a USB flash drive

When you load a USB flash drive that cannot be mounted normally because the file system is destroyed, a message appears on the LCD monitor to ask whether you want to restore it. Select [Execute], then press the SEL/SET button. When formatting is completed, the message “Restore USB Memory Done” is displayed.

Thumbnail Screens

When you press the THUMBNAIL button (page 6), clips recorded on the SxS memory card are displayed as thumbnails on the screen.

You can start playback from the clip selected on the thumbnail screen. The playback picture can be seen on the LCD monitor and external monitors.

Press the STOP/EE button (page 7) to exit the thumbnail screen and return to the recording standby screen.

Note

Even if the SxS memory card contains a mixture of HD and SD clips, the normal thumbnail screen shows only clips of the mode selected in [HD/SD] in [System] (page 57) in the [OTHERS] menu. To display all recorded clips regardless of the HD/SD Mode, switch the screen to the All-Clip thumbnail screen (page 33).

Configuration of the Thumbnail Screen

Data for the clip selected with the cursor are displayed at the bottom of the screen.

The icon of the current SxS memory card is highlighted, shading the nonselected one. (If the card is write-protected, a lock icon is displayed to the left.)

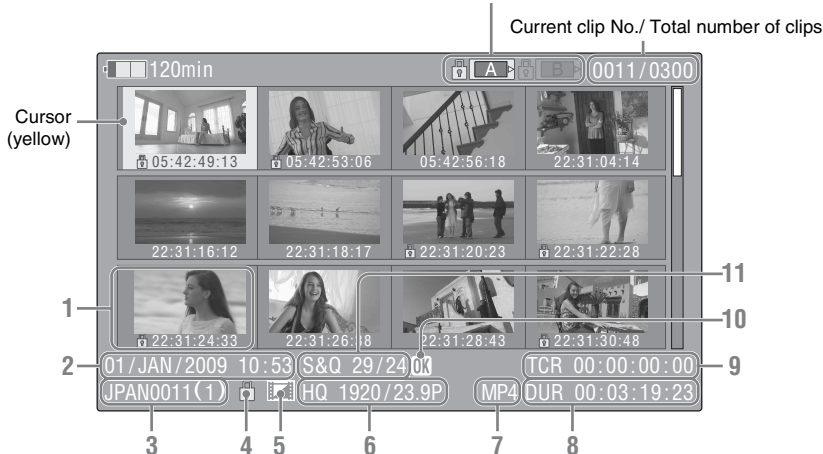

1. Thumbnail

In UDF, exFAT and FAT HD Mode: The thumbnail image for each clip is an index frame from the clip. When recording, the first frame of a clip is automatically set as the index frame. This frame can be adjusted (page 42). If the clip is locked or is set with an OK mark, the lock mark is displayed.

In FAT SD mode: The thumbnail image for each clip is the first frame of the clip. If the file was split into multiple parts because its file size exceeded 2 GB, the take mark is displayed.

Split files can be viewed via the EXPAND CLIP screen (page 39).

2. Date and starting time of recording

3. Clip name

In FAT SD Mode, if the file was split into multiple parts because its file size exceeded 2 GB, the segment number is displayed after the name, separated with a slash.

4. Lock mark

UDF and exFAT: A lock mark appears if the selected clip is locked.

FAT HD Mode: A lock mark appears if the selected clip has an OK mark.

5. AV independent file icon

UDF **exFAT** **FAT/HD**

Displayed only if the selected clip is an AV independent file. This indicates that not all operations and indications may be available, because the clip may have been added manually to the SxS file via a computer, etc., and there is no management file for it.

6. Recording video format

7. File format

The file format (MXF, MP4, AVI) of the selected clip is displayed. (This item is not indicated when the recording mode is UDF/HD mode or exFAT mode.)

8. Duration of the clip

9. Timecode

The timecode of the index frame is displayed.

10. OK/NG/KP mark **UDF** **exFAT** **FAT/HD**

UDF and exFAT: The mark is displayed if the selected clip has an OK/NG/KP flag.

FAT HD Mode: The OK mark is displayed if the selected clip has an OK mark.

11. Special recording information

UDF **exFAT** **FAT/HD**

If the selected clip was recorded in a special recording mode (Slow & Quick Motion, Interval Recording, or Frame Recording), the mode is displayed.

Clips recorded in Slow & Quick Motion display the “Recording frame rate/playback frame rate fps” to the right.

Changing the Type of Thumbnail Screen

The type of thumbnail screen can be changed as follows by pressing the THUMBNAIL button (*page 6*).

UDF and exFAT

The normal thumbnail screen, OK/NG/KP/None clip thumbnail screen, and All-Clip thumbnail screen are cyclically displayed.

FAT HD Mode

The normal thumbnail screen, OK clip thumbnail screen, and All-Clip thumbnail screen are cyclically displayed.

FAT SD Mode

The normal thumbnail screen and All-Clip thumbnail screen are alternately displayed.

OK/NG/KP/None-Clip thumbnail screen

Only the clips flagged OK/NG/KP—or clips with no flag (“None”)—among the clips on the current SxS memory card are displayed.

You can select the type of flag to display with [Filter Clips] in [Clip] (*page 59*) in the [OTHERS] menu.

OK-Clip thumbnail screen

Only the clips marked OK among the clips on the current SxS memory card are displayed.

All-Clip thumbnail screen

The All-Clip thumbnail screen shows all clips on the current SxS memory card regardless of the HD or SD Mode, permitting you to check whether the card contains any clips of another mode than that currently selected.

Note

You cannot start playback from the All-Clip thumbnail screen.

Press the THUMBNAIL button again to return to the normal thumbnail screen, and playback and clip operations are enabled.

Switching the SxS memory cards

When two memory cards are loaded, press the SLOT SELECT button (*page 5*) to switch memory cards.

Note

Card switching is enabled only when the thumbnail screen is displayed or when an external input picture is displayed by pressing the STOP/EE button.

You cannot switch memory cards during playback. Continuous playback of cards in slots A and B is not possible.

Playing Clips

For playback operations, use the playback control buttons on the top panel (page 6). When the IR Remote Commander is enabled, you can use its playback control buttons instead (page 56).

Playing the Selected and Subsequent Clips in Sequence

- 1 Move the cursor to the thumbnail image of the clip with which you wish to start playback.
- 2 Press the PLAY/PAUSE button.
Playback starts from the beginning of the selected clip.

Notes

- The playback picture may be momentarily distorted or frozen between clips. The playback control buttons and THUMBNAIL button do not function during this condition.
- When you select a clip on the thumbnail screen and start playback, the playback picture at the beginning of the clip may be distorted. To start playback without distortion, once pause playback after starting it, press the PREV button to return to the top of the clip, then restart playback.

Information displayed on the playback screen

The following information is superimposed on the playback picture.

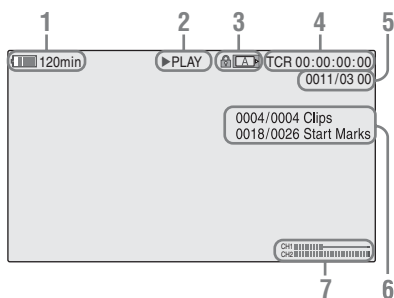

1. Battery remaining/DC IN voltage
2. Playback mode

3. SxS memory card

A  mark appears to the left if the SxS memory card is write-protected.

4. Time data

Each time you press the DURATION/TC/UBIT button, the indication is switched between timecode (TCR) and user-bit (UB) data.

5. Clip no./total number of clips

This is displayed for FAT. It is also displayed for UDF and exFAT, if [Find Mode] in [Clip] (page 59) in the [OTHERS] menu is set to [Clip].

6. Clip no./total number of clips, essence mark no./total number of essence marks

This is displayed for UDF and exFAT, if [Find Mode] in [Clip] (page 59) in the [OTHERS] menu is set to [Rec Start].

7. Audio levels

The audio levels for the recording are displayed.

Playing between In-point and Out-point

The recorder can play a section between start and stop points specified in advance. The recorder plays continuously between the in-point and out-point for the clips after the selected clip.

Note

In FAT/SD mode, playback between in-point and out-point is not supported because shot marks cannot be inserted in clips.

Specifying the In-point and Out-point

Specifying shot mark 1 and shot mark 2 for a clip allows the shot marks to be used as an in-point and out-point, respectively.

When the recorder plays a clip with shot marks recorded on another device, the recorder can play the interval between shot marks 1 and 2 in the same way as for clips recorded on this recorder. When a clip with shot marks recorded on this recorder is played on another device, the shot marks are not treated as an in-point and out-point.

Selecting the Clip to Play

Only clips with an attached OK flag or OK mark support partial playback between in-point and out-point.

To select a clip for partial playback, attach an OK flag or OK mark to the clip on the thumbnail screen.

Playing between In-point and Out-point

Select [PARTIAL PLAYBACK] from the clip operation menus.

Playback starts from the first clip in the OK-Clip thumbnail screen.

When playback of the first clip ends, playback continues with the next clip that has an attached OK flag or OK mark.

If shot mark 1 only is specified, the clip plays from shot mark 1 until the end of the clip. If shot mark 2 only is specified, the clip plays from the start of the clip up to shot mark 2.

Selecting [P-PLAY & SDI REC] in the clip operation menus starts playing between In-point and Out-point and simultaneously outputs a REC trigger signal, allowing you to start proxy file recording using the CBK-WA100. To stop recording on the CBK-WA100, press the STOP/EE button to stop playback and REC trigger output.

Note

When playing between In-point and Out-point, the signal cannot be output on i.LINK (DVCAM/HDV).

Trim: Adjusting the In-point and Out-point

Trimming provides fine control of the playback start point and stop point.

- 1 Display the SHOT MARK screen (page 41).**
- 2 Select the shot mark point you want to trim, then select [TRIM SHOT MARK1/2] in the clip operation menus.**
A still image for the selected frame is displayed.
- 3 Use fast-forward/reverse, play/pause, or slow-motion play (left/right buttons) to move to the frame for which you want to set the shot mark.**

4 Press the SEL/SET button.

The shot mark selected in step 3 is set at the current point, and the display returns to the OK-Clip thumbnail screen.

Playing Clips in Repeat Mode

- 1 Select the thumbnail for the clip you want to play on the thumbnail screen.**
- 2 Select [CLIP REPEAT] in the clip operation menus.**

The selected clip starts playing, loops back to the start of the clip when it reaches the end, and continues playing.

To stop repeat play

Press the STOP/EE button or the THUMBNAIL button.

Monitoring Audio

In Normal playback mode, you can monitor the recorded audio signals through the built-in speaker (page 5) or connected headphones.

With the headphones connected to the headphone connector (page 5), the built-in speaker is turned off.

Press the VOLUME buttons (page 5) to adjust the sound volume.

You can select audio channel(s) to be monitored with [Audio Output] (page 49) in the [AUDIO SET] menu.

Cueing Up

To start playback from the top of the first clip

Press the PREV button and F REV button simultaneously.

To start playback from the top of the last clip

Press the F FWD button and NEXT button simultaneously.

Clip Operations

During thumbnail screen playback, etc., you can operate the clips or confirm and change the subsidiary data for clips using the Clip Operation menus.

The corresponding Clip Operation menu pops up on the screens as shown below when you press the SET/SEL button.

Clip Operation Menus

Thumbnail screen (page 37)

- CANCEL
- DISP CLIP INFO
- OK MARK ADD (FAT only)
- OK MARK DELETE (FAT only)
- OK FLAG ADD (UDF and exFAT)
- NG FLAG ADD (UDF and exFAT)
- KEEP FLAG ADD (UDF and exFAT)
- CLIP FLAG DELETE (UDF and exFAT)
- LOCK CLIP (UDF and exFAT)
- UNLOCK CLIP (UDF and exFAT)
- COPY CLIP(A)
- COPY CLIP(B)
- COPY CLIP(USB)
- DELETE CLIP
- ALL MARKS
- SHOT MARK1
- SHOT MARK2
- REC START MARK (UDF and exFAT)
- EXPAND CLIP
- CLIP REPEAT
- PARTIAL PLAYBACK
- P-PLAY & SDI REC

Playback

Expand Clip screen (page 40)

- CANCEL
- EXPAND(COARSE)
- EXPAND(FINE)
- PAUSE
- SET INDEX PIC
- SHOT MARK1 ADD
- SHOT MARK2 ADD
- SHOT MARK1 DEL
- SHOT MARK2 DEL
- DIVIDE CLIP (FAT only)
- CLIP REPEAT

Shot Mark screen (page 41)

- CANCEL
- PAUSE
- SET INDEX PIC
- SHOT MARK1 DEL
- SHOT MARK2 DEL
- DIVIDE CLIP (FAT only)
- CLIP REPEAT
- TRIM SHOT MARK1
- TRIM SHOT MARK2
- EXPAND(FINEST)

Note

Selectable menu items are limited in SD Mode.

Basic Operations of the Clip Operation Menus

Select a menu item, then press the SEL/SET button. Pressing the CANCEL button restores the previous condition.

Selecting [CANCEL] from a Clip Operation menu turns the Clip Operation menu off.

Notes

- When the SxS memory card is write-protected, some operations are unavailable.
- There may be items that cannot be selected depending on the status when the menu is displayed.

Clip Operation menu on the thumbnail screen

Item	Function
DISP CLIP INFO	Displays the clip's information screen (<i>page 38</i>).
OK MARK ADD ¹⁾	Adds an OK mark (<i>page 39</i>).
OK MARK DELETE ¹⁾	Deletes the OK mark (<i>page 39</i>).
OK FLAG ADD ²⁾	Adds an OK flag (<i>page 38</i>).
NG FLAG ADD ²⁾	Adds a NG flag (<i>page 38</i>).
KEEP FLAG ADD ²⁾	Adds a KP flag (<i>page 38</i>).
CLIP FLAG DELETE ²⁾	Deletes the flag (<i>page 38</i>).
LOCK CLIP ²⁾	Locks and protects a clip (<i>page 38</i>).
UNLOCK CLIP ²⁾	Unlocks a protected clip (<i>page 38</i>).
COPY CLIP(A)	Copies the selected clips to the SxS memory card in slot A or slot B (<i>page 39</i>).
COPY CLIP(B)	
COPY CLIP (USB)	Copies the selected clips to USB media (<i>page 39</i>).
DELETE CLIP	Deletes the clip (<i>page 39</i>).
ALL MARKS ³⁾	Displays thumbnails of all frames with an essence mark recorded (<i>page 41</i>).
SHOT MARK1 ³⁾	Displays only thumbnails of frames with shot mark 1 recorded (<i>page 41</i>).
SHOT MARK2 ³⁾	Displays only thumbnails of frames with shot mark 2 recorded (<i>page 41</i>).
REC START MARK	Displays thumbnails of frames with a Recording Start mark and the first frames of clips without Recording Start marks (<i>page 41</i>).
EXPAND CLIP	Displays the EXPAND CLIP screen (<i>page 39</i>).
CLIP REPEAT	Plays the selected clip repeatedly (<i>page 35</i>).
PARTIAL PLAYBACK	Plays back the clip between the In-point and Out-point (<i>page 35</i>). (OK-clip thumbnail screen only)
P-PLAY & SDI REC	Plays back between the In-point and Out-point and simultaneously outputs a REC trigger signal (<i>page 35</i>). (OK-clip thumbnail screen only)

¹⁾ Effective with FAT HD Mode only.

²⁾ Effective with UDF and exFAT Mode only.

³⁾ Effective with UDF, exFAT and FAT HD Mode.

Displaying the Detailed Information of a Clip

Select [DISP CLIP INFO] from a Clip Operation menu.

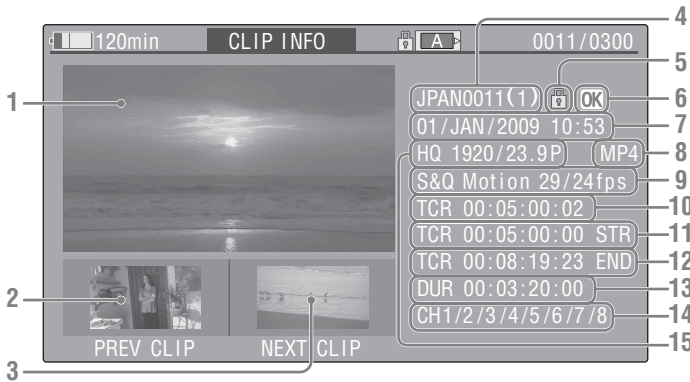

1. Image of the current clip

2. Image of the previous clip

Press the PREV button to switch to the clip info screen of the previous clip.

In FAT SD Mode, the previous segment of a segmented clip is displayed.

3. Image of the next clip

Press the NEXT button to switch to the clip info screen of the next clip.

In FAT SD Mode, the next segment of a segmented clip is displayed.

4. Clip name

For a clip name of 12 characters or longer, only the first 5 and last 5 characters of the name are displayed. To check the non-displayed block of the name, press the SEL/SET button to display the entire clip name (Long-Display mode). Press the SEL/SET button again to cancel Long-Display mode. Long-Display mode is also canceled by switching to the previous or next clip with the PREV or NEXT button.

In FAT SD Mode, if the file was split into multiple parts because its file size exceeded 2 GB, the segment number is displayed after the name, separated with a slash.

5. Lock mark **UDF** **exFAT** **FAT/HD**

UDF and exFAT: A lock mark appears if the selected clip is locked.

FAT HD Mode: A lock mark appears if the selected clip has an OK mark.

6. OK/NG/KP mark **UDF** **exFAT** **FAT/HD**

UDF and exFAT: The mark is displayed if the selected clip has an OK/NG/KP flag.

FAT HD Mode: The OK mark is displayed if the selected clip has an OK mark.

7. Date and starting time of recording

8. File format

The file format (MXF, MP4, AVI) of the selected clip is displayed.

9. Special recording information **UDF** **exFAT** **FAT/HD**

If the selected clip was recorded in a special recording mode (Slow & Quick Motion, Interval Recording, or Frame Recording), the mode is displayed.

Clips recorded in Slow & Quick Motion display the "Recording frame rate/playback frame rate fps" to the right.

10. Timecode of the displayed frame

11. Timecode at the recording starting point

12. Timecode at the recording ending point

13. Duration of the clip

14. Recorded audio channels

15. Recorded video format

OK/NG/KP Flag **UDF** **exFAT**

When adding a flag, you can select from [OK FLAG ADD], [NG FLAG ADD], and [KEEP

FLAG ADD] in the Clip Operation menu (*page 37*) on the thumbnail screen. When deleting a flag, select [CLIP FLAG DELETE].

Note

Flagged clips are not protected. To protect clips from deletion, select [LOCK CLIP] in the Clip Operation menu (*page 37*) on the thumbnail screen. To remove the protection, select [UNLOCK CLIP].

OK Mark **FAT/HD**

Select [OK MARK ADD] from the Clip Operation menu to add the OK mark, or select [OK MARK DELETE] from the Clip Operation menu to delete it.

Copying Clips

You can copy clips on an SxS memory card to another SxS memory card. Each clip is copied with the same name to the destination SxS memory card.

Notes

- If there is another clip having the same name on the destination SxS memory card, the clip is copied under a name adding a single-digit number in parentheses to the end of the original clip name. The parenthetical number is the minimum value that does not exist in the destination memory card.
Examples:
ABCD0002(1) if ABCD0002 exists
ABCD0002(2) if ABCD0002(1) exists
ABCD0005(4) if ABCD0005(3) exists
- When using FAT, you cannot copy a file 10 times or more if clips with the same clip name followed by parenthetical numbers (1) to (9) already exist on the card.
- When using UDF or exFAT, you cannot copy a file 1000 times or more if clips with the same clip name followed by parenthetical numbers (1) to (999) already exist on the card.
- A warning message is displayed if there is not sufficient space on the destination SxS memory card. Replace the SxS memory card with one with sufficient space.
- When copying an SxS memory card on which multiple clips have been recorded, copying all clips to the end may not be achieved, even if the destination card has the same capacity as the source card, depending on usage conditions, memory characteristics, etc.

Copying a specified clip

Select a clip on a thumbnail screen, then select [COPY CLIP(A)] or [COPY CLIP(B)] from the Clip Operation menu.

Copying clips collectively

Select [Clips] in [Copy All] (*page 60*) in the [OTHERS] menu to copy clips on an SxS memory card collectively to another SxS memory card.

If the memory card contains clips of both HD and SD Mode, only the clips of the currently selected mode are copied. This is convenient when you wish to extract clips of the same mode only.

Copying to USB media

When USB media is connected, select a clip on a thumbnail screen and select [COPY CLIP (USB)] from the Clip Operation menu to copy the clip to the USB media.

You can also copy all SxS memory card clips to USB media by selecting [USB SET] > [Copy To USB] in the [OTHERS] menu. This copies only clips for the selected mode in the same way as selecting [Copy All] in the [OTHERS] menu.

Deleting Clips

Select [DELETE CLIP] from the Clip Operation menu.

Note

Clips with an OK mark and flagged clips set to [LOCK CLIP] cannot be deleted. To delete them, release the OK mark or the [LOCK CLIP] setting before performing the delete operation.

Deleting clips collectively

Select [All Clips DEL] in [Clip] (*page 59*) in the [OTHERS] menu.

Notes

- If the memory card contains clips of both HD and SD Mode, only the clips of the currently selected mode are deleted.
- Clips with an OK mark and flagged clips set to [LOCK CLIP] cannot be deleted.

EXPAND CLIP Screen

In UDF, exFAT and FAT HD Mode, the [EXPAND CLIP] screen permits you to divide a clip into 12 blocks of equal duration and show a thumbnail image of the first frame of each block on the screen.

In FAT SD Mode, the [EXPAND CLIP] screen shows the thumbnail images of the first frames of the segment files only for a clip segmented because its file size exceeded 2 GB.

This helps you to quickly cue up to a desired scene in a clip of long duration. You can display the [EXPAND CLIP] screen by selecting the clip on the thumbnail screen.

- 1 Select a clip on the thumbnail screen, then press the SEL/SET button.
- 2 Select [EXPAND CLIP] from the Clip Operation menu.

The EXPAND CLIP screen appears for the clip that you selected on the thumbnail screen.

EXPAND CLIP screen in UDF, exFAT and FAT HD Mode

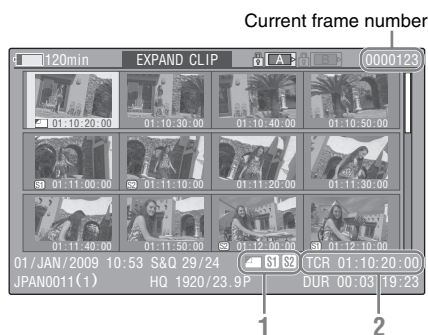

Detailed information for the clip is displayed at the bottom of the screen. The items other than the following are the same as those on the normal thumbnail screen (page 32):

1. Frame information

The following icons show the marking for the frame at the cursor.

	Index frame
	Frame with shot mark 1 added
	Frame with shot mark 2 added

The same icons may also be displayed below the thumbnail image of each frame. If the frame has multiple markings, one of the icons is displayed, in the priority order of index frame, shot mark 1, and shot mark 2.

2. Timecode indication

The timecode of the frame at the cursor is displayed.

EXPAND CLIP screen in FAT SD Mode

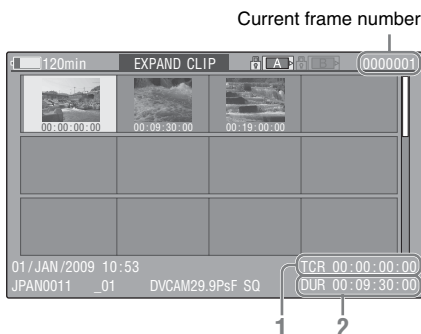

Detailed information for the clip is displayed at the bottom of the screen.

The items other than the following are the same as those on the normal thumbnail screen (page 32):

1. Timecode indication

The timecode of the segmentation file at the cursor is displayed.

2. Duration

The duration of the segmentation file at the cursor is displayed.

Clip Operation menu on the EXPAND CLIP screen

Item	Function
EXPAND (COARSE) ¹⁾	To decrease the number of partitions of the clip
EXPAND (FINE) ¹⁾	To increase the number of partitions of the clip
PAUSE	To set to Pause mode at the selected frame
SET INDEX	To specify the selected frame for the index frame of the clip (page 42)
SHOT MARK1 ADD ¹⁾	To add shot mark 1 to the selected frame (page 41)
SHOT MARK2 ADD ¹⁾	To add shot mark 2 to the selected frame (page 41)
SHOT MARK1 DEL ¹⁾	To delete shot mark 1 from the selected frame (page 41)
SHOT MARK2 DEL ¹⁾	To delete shot mark 2 from the selected frame (page 41)

Item	Function
DIVIDE CLIP ¹⁾	To divide the clip into two clips at the selected frame (<i>page 42</i>)
CLIP REPEAT ¹⁾	Plays the selected clip repeatedly (<i>page 35</i>).

1) Enabled in UDF, exFAT and FAT/HD mode.

SHOT MARK Screen

UDF **exFAT** **FAT/HD**

You can display only those frames with shot marks or recording start marks as thumbnail images on the screen.

- 1 Select a clip on the thumbnail screen, then press the SEL/SET button.
- 2 Select [ALL MARKS], [SHOT MARK1], [SHOT MARK2], or [REC START MARK] from the Clip Operation menu.

SHOT MARK screen example (when [ALL MARKS] is selected)



The detailed information of the clip is displayed at the bottom of the screen.

The items other than the following are the same as those on the EXPAND CLIP screen (*page 40*) in UDF, exFAT and FAT HD mode:

1. Timecode indication

The timecode of the frame at the cursor on the SHOT MARK screen is displayed.

Move the cursor to the first/last frame

First frame: When the cursor is at a user-designated position, press the F REV and PREV buttons simultaneously.

Last frame: Press the F FWD and NEXT buttons simultaneously.

Switch to the clip shot mark screen for a different clip

Previous clip: When the cursor is at the first frame for a clip, press the PREV or up button.

Next clip: When the cursor is at the last frame for a clip, press the NEXT or down button.

Clip Operation menu on the SHOT MARK screen

Item	Function
PAUSE	To set to Pause mode at the selected frame
SET INDEX PIC	To specify the selected frame for the index frame of the clip (<i>page 42</i>)
SHOT MARK1 DEL	To delete the shot mark 1 from the selected frame (<i>page 41</i>)
SHOT MARK2 DEL	To delete the shot mark 2 from the selected frame (<i>page 41</i>)
DIVIDE CLIP	To divide the clip into two clips at the selected frame (<i>page 42</i>) (FAT HD mode Only)
CLIP REPEAT	Plays the selected clip repeatedly (<i>page 35</i>).
TRIM SHOT MARK1	Trims the set position of the specified shot mark 1 (<i>page 35</i>).
TRIM SHOT MARK2	Trims the set position of the specified shot mark 2 (<i>page 35</i>).
EXPAND (FINEST)	Displays the CLIP EXPAND screen, showing the smallest segment of the clip, and displays the selected frame in the center of the screen.

Adding/Deleting Shot Marks

Adding a shot mark in Pause mode

Select [SHOT MARK1 ADD] or [SHOT MARK2 ADD] from the Clip Operation menu.

Adding a shot mark on the EXPAND CLIP screen

Select [SHOT MARK1 ADD] or [SHOT MARK2 ADD] from the Clip Operation menu.

Deleting a shot mark

Select [SHOT MARK1 DEL] or [SHOT MARK2 DEL] from the Clip Operation menu on the [EXPAND CLIP] screen (*page 39*) or on the [SHOT MARK] screen (*page 41*).

Changing the Index Frame

UDF **exFAT** **FAT/HD**

You can change the index frame to another frame you selected on the [EXPAND CLIP] screen (*page 39*) or the [SHOT MARK] screen (*page 41*).

Select [SET INDEX PIC] from the Clip Operation menu.

Note

Even if you specify a frame other than the top frame for the index frame, playback always begins from the top frame when you start it from the thumbnail screen.

Dividing a Clip **FAT/HD**

You can divide a clip into two different clips at the frame you select on the [EXPAND CLIP] screen (*page 39*) or the [SHOT MARK] screen (*page 41*).

Select [DIVIDE CLIP] from the Clip Operation menu.

The first 4 characters of the original clip name are carried on, continuing to the last number on the memory card by the second 4 numerics.

Example: If you divide a clip named “ABCD0002” into two clips under the condition where a new clip will be named “EFGH0100,” clip “ABCD0100” and clip “ABCD0101” are created.

Note

If the remaining space on the memory card is insufficient for divided clips, a message informing you of it appears.

Showing the Status Screens

Press the STATUS button (*page 6*) to display status screens on the LCD monitor/external video monitor.

Use the up/down buttons (*page 6*) to perform operations and switch the screens in sequence. When you press the STATUS button again, the status screen display is canceled.

For connections of an external monitor, see “Connecting External Monitors and Camcorders” on page 65.

Audio Status Screen

[Output CH]: External output/headphone output

Depending on the setting of [Output CH] in [Audio Output] in the [AUDIO SET] menu and the setting of [Monitor CH], the audio channel(s) external output and headphones output is displayed as follows.

- CH-1: When left/right are CH-1
- CH-2: When left/right are CH-2
- CH-3: When left/right are CH-3
- CH-4: When left/right are CH-4
- CH-1/CH-2: When left is CH-1 and right is CH-2 (stereo)
- CH-3/CH-4: When left is CH-3 and right is CH-4 (stereo)
- CH-1+CH-2: When both left and right are CH-1 and CH-2 (monaural)
- CH-3+CH-4: When both left and right are CH-3 and CH-4 (monaural)

[Speaker]: Speaker output

The audio channel(s) output to the internal speaker is displayed.

As the speaker is monaural, “CH-1+CH2” or “CH-3+CH-4” is displayed when [Monitor CH] is set to stereo. With non-stereo settings, the setting of [Monitor CH] in [Audio Output] in the [AUDIO SET] menu is displayed as it is.

[CH-1/CH-2/CH-3/CH-4]: Audio level meters

The 4-channel audio level meters (2 meters when using 2-channel settings) are displayed.

While recording or in standby mode, the level of the audio inputs (EE audio levels) are displayed. During playback, the audio playback level is

displayed according to the setting of [Output CH] in [Audio Output] in the [AUDIO SET] menu.

If audio is input from the i.LINK connector while displaying thumbnails, while playback is stopped, or while recording an external signal, the audio input level is displayed. In this case, the leftmost channels that are displayed are “CH-1” and “CH-2”, regardless of the setting of [Output CH] in [Audio Output] in the [AUDIO SET] menu.

[Input Source]: Input source setting

The audio signal input sources set in [CH1 Input Source] to [CH4 Input Source] in the [AUDIO SET] menu are displayed for each channel.

[Audio Level]: Audio level adjustment method

The audio level adjustment methods set in [Audio Level CH1] and [Audio Level CH2] in the [AUDIO SET] menu are displayed for each channel.

Video Status Screen

[Video Format]: Video format setting

The number of vertical lines, frame rate, and scan format (i/P) of the video format set in [Rec Format] in [System] in the [OTHERS] menu are displayed.

[Rec Mode]: Recording bit rate

The video format set in [Rec Format] in [System] in the [OTHERS] menu is displayed.

[SDI Output]: Output for SDI

The SDI setting in [SDI/HDMI/i.LINK I/O Select] in the [VIDEO SET] menu is displayed.

[SDI Out1 Mode]: Output mode of SDI OUT 1 connector

The output mode of the SDI OUT 1 connector set in [SDI OUT1 Mode Select] in the [VIDEO SET] menu is displayed.

[SDI Out2 Select]: Output signal of SDI OUT 2 connector

The output signal of the SDI OUT 2 connector set in [SDI OUT2 OUTPUT Select] in the [VIDEO SET] menu is displayed.

[3G SDI Out Level]: Data mapping method for 3G SDI signals

The data mapping method for 3G SDI signals set in [3G SDI OUT Level A/B] in the [VIDEO SET] menu is displayed.

[HDMI Output]: Output for HDMI

The HDMI setting in [SDI/HDMI/i.LINK I/O Select] in the [VIDEO SET] menu is displayed.

[i.LINK I/O]: Input and output for i.LINK

The i.LINK setting in [SDI/HDMI/i.LINK I/O Select] in the [VIDEO SET] menu is displayed.

[Input Setting]: Recording source

The input source or SG output setting in [Input Source Select] in the [VIDEO SET] menu is displayed.

[Down Converter]: SD output down-converter setting

The [Down Converter] setting ([Squeeze], [Letterbox], [Edge Crop]) in the [VIDEO SET] menu is displayed.

[23.98P Output]: 23.98P output mode

The [23.98P Output] setting (23.98PsF, 59.94i (2-3 Pull Down)) in the [VIDEO SET] menu is displayed.

Button/Remote Status Screen

[Assign Button]: Assignable button statuses

The functions assigned with the [Assign Button] in the [OTHERS] menu to the respective assignable buttons are displayed.

[IR Remote]: IR Remote Commander status

The [IR Remote] setting in the [OTHERS] menu is displayed.

Battery/Media Status Screen

[Battery]: Battery charge remaining

The remaining charge level of the mounted battery pack is displayed.

[Charge Count]: Repeated charge times

The number of times that the mounted battery pack has been charged is displayed.

[Media A/Media B]: Remaining space, available recording time, and estimated service life (rewriting limit)

The remaining space of the SxS memory cards in the respective card slots is indicated on the meters.

At the right, the available time for recording if done at the current bit rate is displayed, in minutes.

The time indication will be “- - min” if no SxS memory card or an invalid card is in the slot.

If the card is write-protected, a  icon is shown to the right of the time indication.

The Life value is displayed only for an SxS memory card which supports the life value indication. It indicates the estimated remaining usable period of the card (virgin status as 100%). If an alarm is generated, make a backup of the card as soon as possible and replace it with a new card.

[USB Drv]: Remaining capacity of USB media

When USB media is connected, the remaining recording capacity is displayed on the meter.

Overview of the Setup Menus

Press the MENU button to display setup menus on the LCD monitor with settings necessary for recording and playback. (You can also display setup menus on an external monitor.) Set items by selecting them from the following menus.

[AUDIO SET] menu: For setting audio-related items.

[VIDEO SET] menu: For setting video output-related items.

[LCD SET] menu: For setting items related to the LCD monitor.

[TC/UB SET] menu: For setting items related to timecodes and user bits.

[OTHERS] menu: For setting other items.

Setup Menu Layers

MENU

- └ AUDIO SET
 - └ Audio Input
 - └ Audio Output

- └ VIDEO SET
 - └ Input Source Select
 - └ Color Bars On/Off
 - └ Color Bars Type
 - └ SDI/HDMI/i.LINK I/O Select
 - └ SDI OUT1 Mode Select
 - └ SDI OUT2 OUTPUT Select
 - └ 3G SDI OUT Level A/B
 - └ SDI/HDMI/Video Out Super
 - └ Down Converter
 - └ 23.98P Output
 - └ SDI Rec Control
 - └ Clip Cont. Rec Setting
 - └ Segment Loop Rec
 - └ Segment Duration

- └ LCD SET
 - └ LCD
 - └ Display On/Off

- └ TC/UB SET
 - └ Timecode
 - └ Users Bit
 - └ TC Format

└ OTHERS

- └ All Reset
- └ Setup Data
- └ Time Zone
- └ Clock Set
- └ Language
- └ Assign Button
- └ Tally
- └ Hours Meter
- └ IR Remote
- └ Battery Alarm
- └ Battery INFO
- └ Trigger Mode
- └ System
- └ Clip
- └ Copy All
- └ Format Media
- └ Plan.Metadata
- └ Power Enable
- └ Network
- └ Wi-Fi
- └ USB SET
- └ Version
- └ Version Up
- └ Menu Scroll

Basic Menu Operations

Menu controls

MENU button (page 6)

To turn Menu mode to use Setup menus on/off.

Up/Down/Left/Right buttons, SEL/SET button (page 6)

Press the up/down/left/right buttons to move the cursor or the corresponding direction to select menu items or setting values.

Press the SEL/SET button to enter the highlighted item.

CANCEL button (page 6)

To return to the previous layer of the menu. An uncompleted change is canceled.

Setting the Setup menus

Move the cursor to the icon of the menu you wish to set, then push the SEL/SET button to select that menu.

- The menu item selection area can show 7 lines at maximum. When all the selectable items cannot be displayed at one time, you can scroll the display up or down by moving the cursor. A triangle appears at the upper or lower right corner of the menu item selection area to indicate that scrolling is enabled.
- For items having a wide range of available values (example: -99 to +99), the available value area is not displayed. The current setting is highlighted instead, indicating that the setting is ready for change.
- When you select [Execute] for an execution item, the corresponding function is executed.
- When you select an item that you must confirm before execution, the menu display temporarily disappears, and a confirmation message is displayed. Following the instructions of the message, and specify whether to execute or cancel.

Entering a character string

When you select an item for which a character string, such as a time value or filename, is to be specified, the input area for the character string is highlighted, and [SET] appears at the right end.

1 Select characters, then press the SEL/SET button to proceed.

The cursor moves to the next column.

To return to the previous column, press the left button.

2 Perform setting in the same manner up to the last column/digit.

The cursor moves to [SET].

3 Press the SEL/SET button.

The setting is completed.

Setup Menu List

The functions and available settings of menus are listed below.

The default settings set at the factory are shown in bold face (example: **Speed**). The items marked with **[M]** in the Menu items column cannot be set while displaying the thumbnail screen or during playback operations.

[AUDIO SET] Menu

AUDIO SET		
Menu items	Subitems and setting values	Contents
Audio Input Setting for audio inputs (only when audio input box is attached) [M] Note This item cannot be configured when [i.Link] is selected for [Input Source Select] in the [VIDEO SET] menu.	CH1 Input Source SDI IN / Ext	Select the audio signal input source to be recorded as channel 1 for formats that support audio recording. [SDI IN]: Record the CH-1 signal of the SDI IN connector. [Ext]: Record the signal selected in [EXT CH Select].
	CH2 Input Source SDI IN / Ext	Select the audio signal input source to be recorded as channel 2 for formats that support audio recording. [SDI IN]: Record the CH-2 signal of the SDI IN connector. [Ext]: Record the signal selected in [EXT CH Select].
	CH3 Input Source SDI IN / Ext	Select the audio signal input source to be recorded as channel 3 for formats that support 4-channel audio recording. [SDI IN]: Record the CH-3 signal of the SDI IN connector. [Ext]: Record the signal selected in [EXT CH Select].
	CH4 Input Source SDI IN / Ext	Select the audio signal input source to be recorded as channel 4 for formats that support 4-channel audio recording. [SDI IN]: Record the CH-4 signal of the SDI IN connector. [Ext]: Record the signal selected in [EXT CH Select].
	EXT CH Select CH1/CH2 / CH1	Set the signal settings that are selected when [Ext] is selected for [CH1 Input Source] to [CH4 Input Source]. [CH1/CH2]: Input the audio signal from the CH-1 AUDIO IN connector to the odd-numbered channel for which [Ext] is selected, and input the audio signal from the CH-2 AUDIO IN connector to the even-numbered channels. [CH1]: Input the audio signal from the CH-1 AUDIO IN connector to all the channels for which [Ext] is selected.
	Line Input Ref +4dB / 0dB / -3dB / EBUL	Set the reference input level that is used when the input source is set to [Ext] in [CH1 Input Source] to [CH4 Input Source]. The same setting is used for both CH-1 and CH-2 of the AUDIO connector. [Tip] This setting is only enabled when the input source is set to [Ext].
	Reference Level -20dB / -18dB / -16dB / -12dB / EBUL	Set the output level of the 1 kHz test signal. [Tip] This setting is only enabled when the input source is set to [Ext].

AUDIO SET

Menu items	Subitems and setting values	Contents
	Limiter Mode Off / -6dB / -9dB / -12dB / -15dB / -17dB	Select the limiter setting to use on large input signals when [Audio Level CH1] to [Audio Level CH2] are set to [Manual]. [Off]: Do not use. [-6dB] / [-9dB] / [-12dB] / [-15dB] / [-17dB]: Select the level at which the limiter will be activated.
		<div style="border: 1px solid black; padding: 2px; display: inline-block;">Tip</div> <ul style="list-style-type: none"> The limiter limits the peak components of audio signals with wide disparities in levels and compresses audio that exceeds the specified level to prevent excessive outputs. This setting is only enabled when the input source is set to [Ext].
	Audio Level CH1 AUTO / Manual	Select the audio level adjustment method for the CH-1 AUDIO IN connector. [AUTO]: Automatic adjustment (AGC) [Manual]: Manual adjustment
		<div style="border: 1px solid black; padding: 2px; display: inline-block;">Tip</div> <p>This setting is only enabled when the input source is set to [Ext].</p>
	Audio Level CH2 AUTO / Manual	Select the audio level adjustment method for the CH-2 AUDIO IN connector. [AUTO]: Automatic adjustment (AGC) [Manual]: Manual adjustment
		<div style="border: 1px solid black; padding: 2px; display: inline-block;">Tip</div> <p>This setting is only enabled when the input source is set to [Ext].</p>
	AGC Spec -6dB / -9dB / -12dB / -15dB / -17dB	Select the level at which AGC (auto gain control) controls the audio level of the AUDIO IN connectors.
		<div style="border: 1px solid black; padding: 2px; display: inline-block;">Tip</div> <p>This setting is only enabled when the input source is set to [Ext].</p>
	CH1&2 AGC Mode Mono / Stereo	Select the automatic adjustment method that is used for the input levels of the analog audio signals that are recorded to CH-1 and CH-2 from the AUDIO IN connectors. [Mono]: Adjust separately for each channel. [Stereo]: Adjust in stereo mode.
		<div style="border: 1px solid black; padding: 2px; display: inline-block;">Tip</div> <p>This setting is only enabled when the input source is set to [Ext].</p>
	CH3&4 AGC Mode Mono / Stereo / Off	Select the automatic adjustment method that is used for the input levels of the analog audio signals that are recorded to CH-3 and CH-4 from the AUDIO IN connectors. [Mono]: Adjust separately for each channel. [Stereo]: Adjust in stereo mode. [Off]: Do not perform automatic adjustment.
		<div style="border: 1px solid black; padding: 2px; display: inline-block;">Tip</div> <p>This setting is only enabled when the input source is set to [Ext].</p>

AUDIO SET		
Menu items	Subitems and setting values	Contents
Audio Output Setting for audio outputs	1KHz Tone On / Off	Turn the 1-kHz reference tone signal on/off.
	Monitor CH CH-1/CH-2 (CH-3/CH-4) CH-1+CH-2 (CH-3+CH-4) CH-1 (CH-3) CH-2 (CH-4)	Select the audio channel(s) to be fed to the headphones and the built-in speaker. [CH-1/CH-2 (CH-3/CH-4)]: Stereo [CH-1+CH-2 (CH-3+CH-4)]: Mix [CH-1 (CH-3)]: CH-1 (CH-3) only [CH-2 (CH-4)]: CH-2 (CH-4) only (): with [Output CH] set to [CH-3/CH-4]
	Output CH CH-1/CH-2 CH-3/CH-4	Select audio output channels from either channels 1 and 2 or channels 3 and 4.
	Alarm Level 0 to 7 (4)	Set the alarm sound volume.

[VIDEO SET] Menu

VIDEO SET		
Menu items	Setting values	Contents
Input Source Select Setting the input source	SDI / i.LINK	Select video and audio signal for the input source. [SDI]: Input from SDI IN connector [i.LINK]: HDV/DVCAM input via the i.LINK connector Note i.LINK is unavailable in UDF/HD mode and exFAT mode.
Color Bars On/Off Setting the Color Bars	On / Off	Turn color bars output on/off when [Input Source Select] is set to [SDI].
Color Bars Type Selecting the type of color bars	Multi / 75% / 100% / SMPTE	Select the type of color bars to be output when [Color Bars On/Off] is set to [On]. [Multi]: Multifformat color bars are output. [75%]: To output 75% color bars [100%]: To output 100% color bars [SMPTE]: To output SMPTE color bars.

VIDEO SET		
Menu items	Setting values	Contents
SDI/HDMI/i.LINK I/O Select Selecting input/output signals for the connectors	In UDF/HD mode	[3G (SDI)]: Output a 3G SDI signal from the SDI OUT 1/2 connectors, and an HD HDMI signal from the HDMI OUT connector.
	HD	[HD]: Output an HD SDI signal from the SDI OUT 1/2 connectors, and an HD HDMI signal from the HDMI OUT connector.
	SD	[SD]: Output an SD SDI signal from the SDI OUT 1/2 connectors, and an SD HDMI interlaced signal from the HDMI OUT connector. In UDF/SD mode, DVCAM stream is input/output on the i.LINK connector.
	SD P	[HD & HDV]: Output an HD SDI signal from the SDI OUT 1/2 connectors, and an HD HDMI signal from the HDMI OUT connector. Input/output an HDV stream on the i.LINK connector.
	Off	[SD & HDV]: Output an SD SDI signal from the SDI OUT 1/2 connectors, and an SD HDMI interlaced signal from the HDMI OUT connector. Input/output an HDV stream on the i.LINK connector.
	In exFAT/HD mode	[SD P & HDV]: Output an SD HDMI progressive signal from the HDMI OUT connector. Input/output an HDV stream on the i.LINK connector. No signal is output from the SDI OUT and VIDEO OUT connectors.
	3G (SDI)	[SD & DVCAM]: Output an SD SDI signal from the SDI OUT 1/2 connectors, and an SD HDMI interlaced signal from the HDMI OUT connector. Input/output a DVCAM stream on the i.LINK connector.
	HD	[SD P]: Output an SD HDMI progressive signal on the HDMI OUT connector. No signal is output from the SDI OUT 1/2 and VIDEO OUT connectors.
	SD	[Off]: No output from each of the SDI/HDMI/i.LINK connectors. A composite signal is output when composite signal output from the VIDEO OUT connector is enabled.
	SD P	
	Off	
	In FAT/HD mode (HQ)	
	HD	
	SD & DVCAM	
	SD P	
	Off	
In FAT/HD mode (SP)		
HD & HDV		
SD & HDV		
SD P & HDV		
SD & DVCAM		
Off		
In UDF/SD mode		
SD		
Off		
In exFAT/SD mode		
SD		
Off		
In FAT/SD mode		
SD & DVCAM		
Off		
SDI OUT1 Mode Select Setting the output mode of the SDI OUT 1 connector	Normal / Through / Auto	Set the video signal output mode for the SDI OUT 1 connector. [Normal]: Output the same video as the LCD monitor. [Through]: Always perform through output of the SDI IN input signal. [Auto]: Output the playback video when playback is being performed on the recorder, and output the SDI IN input signal at all other times.
SDI OUT2 OUTPUT Select Setting the output signal of the SDI OUT 2 connector	3G / HD	Set the output signal of the SDI OUT 2 connector. [3G]: Output a 3G SDI signal. [HD]: Output an HD SDI signal. Tip This setting is only enabled when the [SDI/HDMI/i.LINK I/O Select] is set to [3G (SDI)]. Note When [3G (SDI)] is not selected, the signal set in [SDI/HDMI/i.LINK I/O Select] will be output. However, if [System] >[HD/SD] is set to [HD] and [SDI/HDMI/i.LINK I/O Select] is set to [SD], no signal will be output.

VIDEO SET		
Menu items	Setting values	Contents
3G SDI OUT Level A/B Setting the 3G SDI output signal format	LevelA / LevelB	Select the data mapping method for 3G SDI output signals. Tips <ul style="list-style-type: none"> Support for Level A is planned for future updates. This setting is only enabled when the [SDI/HDMI/i.LINK I/O Select] is set to [3G (SDI)].
SDI/HDMI/Video Out Super Setting the character information for each output	On / Off	Set whether to add the menus and status indications of the LCD monitor to the output of the SDI OUT 1/2, HDMI OUT, and VIDEO OUT connectors. Note On the thumbnail, EXPAND CLIP and SHOT MARK screens, the menus and status indications on the LCD monitor are displayed regardless of the setting of this item.
Down Converter Selecting the operation mode of the down converter	Squeeze / Letterbox / Edge Crop	Set the output mode (aspect) for SD signals [Squeeze]: To horizontally reduce a 16:9 picture to output a 4:3 picture [Letterbox]: To mask the upper and lower areas of a 4:3 picture to display a 16:9 picture in the center of the screen [Edge Crop]: To cut the both sides of a 16:9 picture to output a 4:3 picture
23.98P Output Selecting Output mode	59.94i (2-3PD)/ 23.98PsF	Select the output format for the following video formats. For UDF/HD mode: HD422 50/1080/23.98P, HQ 1920×1080/23.98P, HQ 1440×1080/23.98P For exFAT/HD mode: XAVC-I 1080/23.98P, XAVC-L50 1080/23.98P, XAVC-L35 1080/23.98P, HD422 50/1080/23.98P, HQ 1920×1080/23.98P, HQ 1440×1080/23.98P For FAT/HD mode: HQ 1920×1080/23.98P, HQ 1440×1080/23.98P
SDI Rec Control Setting the synchronized recording	Off / On	Select whether to start/stop recording in synchronization with an REC trigger signal sent from the device connected to the SDI IN connector.
Clip Cont. Rec Setting Setting the Clip Continuous Recording function	On / Off	Turn the Clip Continuous Recording function on/off.
Segment Loop Rec Setting loop recording	On / Off	Turn loop recording using two SxS memory cards on/off.
Segment Duration Setting loop recording retention time	15-35min / 30-65min	Set the retention time of video during loop recording. Cannot be selected if the remaining recording time of the SxS memory cards is less than the capacity required for recording.

[LCD SET] Menu

LCD SET		
Menu items	Subitems and setting values	Contents
LCD Adjusting the LCD monitor	Color -99 to +99 (± 0)	Adjust the color of pictures on the LCD monitor.
	Contrast -99 to +99 (± 0)	Adjust the contrast of pictures on the LCD monitor.
	Brightness -99 to +99 (± 0)	Adjust the brightness of pictures on the LCD monitor.
Display On/Off Selecting the items to be displayed on the LCD monitor [M]	Audio Level Meter On / Off	Turn the audio level meter indication on/off.
	Timecode On / Off	Turn the time data (timecode, user bits, duration) indication on/off.
	Battery Remain On / Off	Turn the battery remaining/DC input voltage indication on/off.
	Media Remain On / Off	Turn the media remaining indication on/off.
	Video Format On / Off	Turn the video format indication on/off.
	Clip Name On / Off	Turn the clip name display on/off.
	ClipNumber (PB) On / Off	Turn the clip number display on/off.
	SDI Rec Control On / Off	Turn the synchronous recording display (the Rec2 display) on/off.
	Input Signal I/F On / Off	Turn the input signal display ON/OFF.
	Wireless Status On / Off	Turn the wireless signal status indication on/off when using the CBK-WA100.
	Ext Media Remain On / Off	Turn the SD card remaining capacity indication on/off when using the CBK-WA100.
	Sending Clip Info On / Off	Turn the clip transfer status indication on/off when using the CBK-WA100.

[TC/UB] SET Menu

TC/UB SET		
Menu items	Subitems and setting values	Contents
Timecode Setting the timecode	Mode Preset / Regen / Ext Regen / Clock	Set the timecode mode. [Preset]: To start the timecode from the specified value [Regen] (regeneration): To continue the timecode during recording only. When you insert another SxS memory card, the recorder starts next recording so that the timecode continues from the last recorded timecode on the card. [ExtRegen] (external regeneration): To synchronize to the timecode superimposed on the internal input signal. [Clock]: To use the current clock time as the timecode
	Run Rec Run / Free Run	Set the running mode when the timecode mode is set to [Preset]. [Rec Run]: To advance the timecode during recording only. The continuity of the timecode is maintained between clips in the sequence of recording as long as the SxS memory card is not changed. If you remove the memory card and record on another card, the timecode will not continue when you return the first card to the slot again. [Free Run]: The timecode keeps advancing regardless of the state of recording to the SxS memory card. Always select [Free Run] when [Mode] is set to [ExtRegen].
	Setting	Set the timecode to a desired value.
	Reset Execute / Cancel	Select [Execute] to reset the timecode to "00:00:00:00."
Users Bit Setting the user bits	Mode Fix / Date	Set the user bit mode. [Fix]: To use a desired fixed value as the user bits [Date]: To use the current date
	Setting	Set the user bits to a desired value.

TC/UB SET		
Menu items	Subitems and setting values	Contents
TC Format Setting the time code format	DF / NDF	Set the timecode format. [DF]: Drop frame [NDF]: Non drop frame
<div style="border: 1px solid black; padding: 2px; margin: 5px 0;">Note</div> <p>The current video format/frame frequency determines whether the mode is fixed either to DF or NDF (see below), regardless of the [TC Format] setting.</p>		
Video formats	Frame setting	TC Format
59.94i 59.94P 29.97P	00 to 29	DF/NDF switchable (Fixed to DF in Clock mode)
23.98P	00 to 23 ¹⁾	Fixed to NDF ²⁾
50i 50P 25P	00 to 24	Fixed to NDF

1) The frame digits in [Setting] is limited to 00, 04, 08, 12, 16, and 20.

The frame at the beginning of recording is limited to 00, 04, 08, 12, 16, or 20.

As [23.98P Output] (*page 51*) in the [VIDEO SET] menu becomes 2-3 pull-down 59.94i when recording (or standing by to record) HQ 1920/23.98P other than when [23.98PsF] is selected, the overlapping timecodes of frames output from the SDI OUT 1/2 connectors are renumbered from 00 to 29.

2) Even in [Clock] mode, the timecode is gradually shifted, because it is counted by NDF.

As output from the SDI OUT 1/2 connectors becomes 2-3 pulled-down video when recording (or standing by to record) HQ 1920/23.98P and other than [23.98PsF] is selected for [23.98P Output] (*page 51*) in the [VIDEO SET] menu, fields are created in which overlapping timecodes are displayed on the screen.

[OTHERS] Menu

OTHERS		
Menu items	Subitems and setting values	Contents
All Reset Resetting to the factory status	Execute/Cancel	Select [Execute] to reset the recorder to the factory status.

OTHERS		
Menu items	Subitems and setting values	Contents
Setup Data Storing/recalling the menu settings on SxS memory cards or USB flash drive	Store(SxS)/(USB) Execute/Cancel	When you select [Execute] to store the setting values, the setup file is stored to one of the following directories. When using SxS memory cards For UDF: /General/Sony/PRO/CAMERA/XDCAM/PMW_rx50/ For exFAT: /XDROOT/General/Sony/PRO/CAMERA/XDCAM/PMW_RX50 For FAT: /SONY/PRO/CAMERA/XDCAM_EX/PMW_rx50/ When using USB flash drives For USB flash drives formatted in FAT32: /MSSONY/SONY/PRO/CAMERA/XDCAM/PMW_RX50
		Tip The setup file cannot be saved to a USB flash drive formatted in exFAT.
Time Zone Setting the time difference	UTC -12:00 to +13:30 Execute/Cancel	Select [Execute] to retrieve the setting values from an SxS memory card.
		Set the time-zone difference from UTC in steps of 30 minutes. Note The default setting is different among the sales areas. United States and Canada: -5:00 Europe area: 0:00 Oceania: +10:00
Clock Set Setting the built-in clock	Date/Time	Set the current time and date.
	12H/24H 12H / 24H	Select the display mode of time. [12H]: 12-hour mode [24H]: 24-hour mode
	Date Mode YYMMDD / MMDDYY / DDMMYY	Select the display mode of the date. [YYMMDD]: In sequence of year, month, day [MMDDYY]: In sequence of month, day, year [DDMMYY]: In sequence of day, month, year
Language Selecting the language for menus and messages	English / Japanese / Chinese	[English]: To display in English [Japanese]: To display in Japanese [Chinese]: To display in Chinese
		Note [Japanese] is valid only on messages for warning and caution. The menus and status indications do not change.

OTHERS		
Menu items	Subitems and setting values	Contents
Assign Button Assigning functions to the assignable buttons	<1>, <2>, <3>, <4>, <5> Off / Last Clip DEL / IR Remote / Shot Mark1 / Shot Mark2 / OK Mark / Clip Flag OK / Clip Flag NG / Clip Flag Keep / Clip Continuous Rec / Clip Update / Play & SDI Rec / LCD Adjust / Color Bars On/ Off / Quick Backup / USB Thumbnail View / Partial Playback/ STATUS / LCD BRIGHT / DISPLAY <1> On <2> Off <3> STATUS <4> LCD BRIGHT <5> DISPLAY	Assign a function to the ASSIGN 1/2/3/4/5 buttons. (The selectable functions are shared). [Off]: No function [Last Clip DEL]: Execute the last clip delete (retake) function [IR Remote]: Enable/disable the IR Remote Commander. [Shot Mark1]: Add shot mark 1 (HD Mode only). [Shot Mark2]: Add shot mark 2 (HD Mode only). [OK Mark]: For adding or removing an OK mark (HD Mode only, not valid via the thumbnail screen). [Clip Flag OK]: Enable/disable OK flags for clips during recording and playback (UDF and exFAT). [Clip Flag NG]: Enable/disable NG flags for clips during recording and playback (UDF and exFAT). [Clip Flag Keep]: Enable/disable Keep flags for clips during recording and playback (UDF and exFAT). [Clip Continuous Rec]: Switch the Clip Continuous Recording function on/off. [Clip Update]: Update the management file on the selected SxS memory card (not supported in continuous recording mode). [Play & SDI Rec]: Start playback and REC trigger output, or pause playback and stop REC trigger output (when using the CBK-WA100). [LCD Adjust]: Switch the LCD Adjust function level bar indication (brightness adjustment → contrast adjustment → off). [Color Bars On/Off]: Switch the color bars output on/off. [Quick Backup]: Backup all clips from the selected SxS memory card to a new folder on USB media. [USB Thumbnail View]: Display the USB media thumbnail screen. [Partial Playback]: Playback between In-point and Out-point [STATUS]: Display the status screens on LCD monitors and external monitors. [LCD BRIGHT]: Adjust the backlight brightness for the LCD monitor. [DISPLAY]: Enable/disable display of the recorder's status information and settings on the LCD monitor's video.
Tally Setting the tally lamps	Front High / Low / Off	Set the brightness of the tally lamp.
Hours Meter Displaying the hours meter	Hours (Sys) Hours (Reset) Reset Execute/Cancel	The non-resettable accumulated time of use is displayed. The resettable accumulated time of use is displayed. Select [Execute] to reset the [Hours (Reset)] value to 0.
IR Remote Activating/deactivating the Remote Commander	On / Off	Set to [On] to activate remote control operations from the supplied IR Remote Commander. Note The setting automatically returns to [Off] when the recorder is turned off.

OTHERS		
Menu items	Subitems and setting values	Contents
Battery Alarm Setting the low power alarm	Low BATT 5% / 10% / 15% / ... / 45% / 50%	Set the battery level at which the Low BATT warning is generated (in steps of 5%).
	BATT Empty 3% to 7% (3%)	Set the battery level at which the BATT Empty warning is generated.
	DC Low Volt1 11.5 V to 17.0 V (11.5 V)	Set the DC IN voltage at which the DC Low Volt1 warning is generated.
	DC Low Volt2 11.0 V to 14.0 V (11.0 V)	Set the DC IN voltage at which the DC Low Volt2 warning is generated.
Battery INFO Showing information regarding the battery pack (display only)	Type	The type (product name) is displayed.
	MFG Date	The date of manufacture is displayed.
	Charge Count	The accumulated number of times of charge/discharge is displayed.
	Capacity	The estimated total capacity of full charge is displayed.
	Voltage	The current output voltage is displayed.
	Remaining	The current remaining level is displayed.
Trigger Mode Setting for operating an external recording device connected via the i.LINK connector (FAT only) <input type="checkbox"/> M	Internal / Both / External	[Internal]: To activate recording start/stop operations only for an SxS memory card in a built-in slot. [Both]: To activate recording start/stop operations both for an SxS memory card in a built-in slot and the external recording device connected via the i.LINK connector. [External]: To activate recording start/stop operations only for the external recording device connected via the i.LINK connector.
System	Country NTSC Area / NTSC(J) Area / PAL Area	Select the area of use and setup ON/OFF setting. [NTSC Area]: Setup ON [NTSC(J) Area]: Setup OFF [PAL Area]: Setup OFF Note The default setting is different among the sales areas. United States and Canada: NTSC Area Other areas: PAL Area
	F.Sys. UDF / exFAT / FAT	Switch the file system between UDF/exFAT/FAT.
	HD/SD HD / SD	Switch between HD Mode and SD Mode for recording/playback.
	XAVC/MPEG2 XAVC / MPEG2	Switch between the XAVC and MPEG2 formats during exFAT and HD mode.

OTHERS

Menu items	Subitems and setting values	Contents
	Rec Format	Select the video format for recording. The selectable video formats for recording will differ depending on the mode. HD Mode <ul style="list-style-type: none"> • Bit rate <ul style="list-style-type: none"> UDF: HD422 50 or HD420 HQ exFat: XAVC, HD422 50, or HD420 HQ FAT: HQ or SP • Horizontal resolution <ul style="list-style-type: none"> 1920, 1440, or 1280 • Frame rate <ul style="list-style-type: none"> 23.98, 25, 29.97, 50, or 59.94 • Scan system <ul style="list-style-type: none"> i (interlace) or P (progressive) SD Mode <ul style="list-style-type: none"> • Frame rate <ul style="list-style-type: none"> 50 or 59.94 • Scan system <ul style="list-style-type: none"> i (interlace) For details on the selectable video formats for recording in each mode, see “Recording Video Formats ([Rec Format])” (page 74).
	Wide Mode Auto / 16:9	Set wide video processing when the input signal is an SD SDI signal. [Auto]: To set squeeze mode when the input signal is wide video or set to edge crop mode when the input signal is not wide video. [16:9]: To set fixed squeeze mode to always treat the input signal as wide video.
	Audio (IMX) 16bit / 24bit	Set the number of audio quantization bits when the video format is IMX.

OTHERS		
Menu items	Subitems and setting values	Contents
Clip Setting for clip name or deletion	Auto Naming C**** / Title / Plan	Select the method to specify clip names. C****: UDF and exFAT [Title]: To specify as desired by [Title Prefix] [Plan]: To use a name specified in planning metadata (if no name is specified in planning metadata, the name specified by [Title Prefix] is used.)
	Title Prefix nnn_ (nnn=least three digits of the serial number) (Max. 7 characters displayed)	Call the [Character Set] screen to set the title part (4 to 46 characters) of the clip names. Configuration of the [Character Set] screen Character selection area (3 lines): To select a character to insert in the cursor position of the Title Prefix area. !#\$%()+,.-=@[]^_~0123456789 abcdefghijklmnopqrstuvwxyz ABCDEFGHIJKLMNOPQRSTUVWXYZ Cursor operation area (1 line): [Space]: To change the character in the cursor position to a space [INS]: To insert a space in the cursor position [DEL]: To delete a character in the cursor position [←]: To move the cursor to the left [→]: To move the cursor to the right [ESC]: To cancel the change and exit the [Character Set] screen [END]: To validate the change and exit the [Character Set] screen [Title Prefix] area (1 line): For entering the title To set the title 1 Select (highlight) a character in the character selection area to be entered in the cursor position of the [Title Prefix] area. Then press the SEL/SET button. 2 Repeat Step 1 for setting the title. (Use [Space], [INS], and [DEL] as required.) 3 When the title setting is completed, select [END] to exit the [Character Set] screen.
	Number Set 0001 to 9999	Set the second 4-numeric part of the clip name.
	Update Media(A) / Media(B)	To update the managerial file on the SxS memory card in the selected slot. ¹⁾
	Last Clip DEL Execute / Cancel	Select [Execute] to delete the last recorded clip.
	All Clips DEL Execute / Cancel	Select [Execute] to delete all clips on the active SxS memory card.
		Note Clips to which you applied OK mark and clips that are locked cannot be deleted.
	Filter Clips OK / NG / KP / None	Select from among [OK] (the OK flag), [NG] (the not good flag), [KP] (the keep flag), or [None] (for no flag) to filter displayed clips. (UDF and exFAT)
	Lock All Clips Execute/Cancel	Select [Execute] to protect all clips. (UDF and exFAT)

OTHERS

Menu items	Subitems and setting values	Contents
	Unlock All Clips Execute/Cancel	Select [Execute] to remove protection from all clips. (UDF and exFAT)
	Index Picture Pos 0sec to 10sec (0sec)	Set the image for viewing thumbnails. This selects the time difference from the start of the clip.
	Find Mode Clip / Rec Start	Set the action for when you press the PREV button/NEXT button. (UDF and exFAT) [Clip]: Move to the start of the current clip/next clip. (Pressing the PREV button from the start of a clip will move to the start of the previous clip.) [Rec Start]: Move to the previous [Rec Start Essence Mark]/the next [Rec Start Essence Mark].
Copy All ²⁾ Setting for collective copy of clips and/or "General" files	Clips	To copy all clips on an SxS memory card to the other.
	General Files	To copy all files in the "General" folder on an SxS memory card to the other.
	Clips&General	To copy all clips and files in the "General" folder on an SxS memory card to the other.
Format Media Formatting SxS memory cards	Media(A) Execute / Cancel	Select [Execute] to format the SxS memory card in slot A with the selected file system (UDF/exFAT/FAT).
	Media(B) Execute / Cancel	Select [Execute] to format the SxS memory card in slot B with the selected file system (UDF/exFAT/FAT).
Plan.Metadata Setting planning metadata	Load/Slot(A) or Load/Slot(B) Execute / Cancel	To load planning metadata from the SxS memory card in slot A or B. Selecting [Execute] displays the list of the planning metadata files stored on the SxS memory card in slot A or B. Specify a file, select [Load] then [Execute] for loading.
		<div style="background-color: #cccccc; padding: 2px;">Notes</div> <ul style="list-style-type: none"> The file list displays up to 64 files. Even if the total number of planning metadata files is 64 or less, all of the planning metadata files may not appear if the directory where they are located in the SxS memory card (General/Sony/Planning) contains 512 or more files. After you start loading, do not remove the SxS memory card until the completion message is displayed.
	Load/USB (UDF and exFAT mode) Execute/Cancel	Loads planning metadata from the USB flash drive connected to the external device connector. Select [Execute] to show the list of the planning metadata files stored in the USB flash drive and select a file to be loaded.

OTHERS		
Menu items	Subitems and setting values	Contents
	Properties Execute / Cancel	Select [Execute] to display the detailed information of the planning metadata loaded in the recorder. [File Name]: Filename [Assign ID]: Assignment ID [Created]: Time and date of creation [Modified]: Time and date of most recent modification [Modified by]: Name of person who modified the file [Title1]: Title1 specified in file (clip name in ASCII format) [Title2]: Title2 specified in file (clip name in UTF-8 format) [Material Gp]: Number of material groups (groups of clips recorded using the same planning metadata) [Shot Mark1]: Name defined for Shot Mark 1 [Shot Mark2]: Name defined for Shot Mark 2 When you select [File Name], [Assign ID], [Title1], or [Title2] on the Planning Metadata Properties screen and then press the SEL/SET button, the selected item is displayed on the full screen, permitting you to check a long file or clip name at a glance.
		Note Names of shot marks cannot be displayed on the full screen even if you select [Shot Mark1] or [Shot Mark2].
	Clear Execute / Cancel	Select [Execute] to clear the planning metadata loaded in the recorder.
	Clip Name Disp Title1 (ASCII) / Title2 (UTF-8)	Select the display mode of the clip name specified in planning metadata.
		Note When both an ASCII format name and a UTF-8 format name are specified in planning metadata, the UTF-8 format string is used as the clip name. If only either ASCII-format name or UTF-8 format name is specified in planning metadata, the specified name is displayed regardless of the menu setting.
Power Enable Setting specifying the connector that supplies power to external equipment	Sony Wireless Adapter / USB A	Set the connector that supplies power to external equipment. [Sony Wireless Adapter]: Supply power from the DC OUT connector (for CBK-WA100). [USB A]: Supply power from the USB (HOST) connector.
Network Setting for network connections	DHCP Enable / Disable	Select whether to acquire the IP address automatically from a DHCP server ([Enable]) or not ([Disable]).
	IP Address 0.0.0.0 to 255.255.255.255 (192.168.1.10)	Set the IP address when [DHCP] is set to [Disable].
	Subnet Mask 0.0.0.0 to 255.255.255.255 (255.255.255.0)	Set the subnet mask when [DHCP] is set to [Disable].
Note IFU-WLM3 is required.	Default Gateway 0.0.0.0 to 255.255.255.255 (0.0.0.0)	Set the default gateway when [DHCP] is set to [Disable].
	User Name (admin)	Set a desired user name in 1 to 31 alphanumeric characters.

OTHERS

Menu items	Subitems and setting values	Contents
	Password (pmw-rx50)	Sets a password in 0 to 31 alphanumeric characters. Note Each password character is displayed as “ * ” (asterisk).
	Set Execute / Cancel	Confirms the [Network] settings. Select [Execute] to confirm.
	MAC Address	Display the MAC address.
	Net Config Reset Execute / Cancel	Reset the [Network] settings to the preset values. Select [Execute] to reset.
Wi-Fi Setting for Wi-Fi connection	Scan Networks Execute / Cancel	Scan the available network connections when [Wi-Fi] is set to [Enable]. Note “Unknown” is displayed as the scan result when using the IFU-WLM3. In this case, set [Network Type] to [Infra] or [Adhoc].
Note IFU-WLM3 is required. This menu is not available when using the CBK-WA100.	SSID (Network connection name display) Reset	Reset the network connection name to the default settings.
	Network Type Infra / Adhoc	Select the connection mode. [Infra]: Infrastructure mode [Adhoc]: Ad hoc mode
	Ch 1 to 11	Set the wireless channel when [Network Type] is [Adhoc].
	Authentication When [Network Type] is [Infra] Open / Shared / WPA / WPA2 When [Network Type] is [Adhoc] Open / Shared	Select the network authentication. [Open]: Open system authentication [Shared]: Shared key authentication [WPA]: WPA (Wi-Fi Protected Access) authentication [WPA2]: WPA2 (Wi-Fi Protected Access 2) authentication
	Encryption When [Authentication] is [Open] or [Shared] Disable / WEP When [Authentication] is [WPA] or [WPA2] Disable / TKIP / AES	Select the type of data encryption. [Disable]: Do not apply data encryption. [WEP]: WEP (Wired Equivalent Privacy) [TKIP]: TKIP (Temporal Key Integrity Protocol) [AES]: AES (Advanced Encryption Standard)
	WEP Key Index 1 / 2 / 3 / 4	Select the key index when [Encryption] is [WEP].
	Input Select When [Encryption] is [WEP] ASCII5 / ASCII13 / HEX10 / HEX26 When [Encryption] is [TKIP] or [AES] ASCII8-63 / HEX64	Select the input format depending on the network key (or security key). [ASCII5]: Five characters ASCII format [ASCII13]: 13 characters ASCII format [HEX10]: 10 hexadecimal digits [HEX26]: 26 hexadecimal digits [ASCII8-63]: 8 to 63 characters ASCII 8-bit format [HEX64]: 64 hexadecimal digits (characters)
	Key (network key)	Set the network key (or security key).
	Set Execute / Cancel	Confirm the [Wi-Fi] settings when [Wi-Fi] is set to [Enable]. Select [Execute] to confirm.

OTHERS		
Menu items	Subitems and setting values	Contents
	Wi-Fi Status ■ ■ ■ Connecting (display only)	Display “Connecting” while connection is being attempted. Display black squares to show the connection status by the number of squares during communication. Note [Wi-Fi Status] is displayed when using the IFU-WLM3 in Adhoc mode.
	Wireless Mode 802.11b / 802.11g / 802.11n	Display an IEEE802.11 standard.
	Wi-Fi Enable / Disable	Select whether to enable or disable Wi-Fi connection.
	Wi-Fi Remote On / Off	Select whether to enable or disable Wi-Fi remote control.
USB SET	Thumbnail View Execute / Cancel	Display the USB media thumbnail screen.
Setting for USB media connection	Select Folder	Select a folder on USB media as the destination when copying clips and for display on the thumbnail screen. Select [New] to create a new folder.
	Rename Folder	Rename the current folder.
	Error Check On / Off	Select whether to perform error checking when copying clips.
	Format USB exFAT / FAT32	Format USB media. [exFAT]: Format USB media for copying clips. [FAT32]: Format USB flash drive for writing planning metadata (UDF and exFAT mode).
	Copy To USB A → USB / B → USB / A&B → USB	Copy SxS memory card clips to USB media. Note Available only when the thumbnail screen is displayed.
	Copy From USB USB → A / USB → B	Copy USB media clips to SxS memory card. Note Available only when the thumbnail screen is displayed.
	With General Enable / Disable	Enable/disable copying of files in the “General” folder when copying clips.
Version	Vx.xx	The current software version of the recorder is displayed.
Showing the version of this unit		
Version Up	Execute / Cancel	Select [Execute] to update the recorder. Use when updating is required. Note This item cannot be selected when no SxS memory card has been loaded.
Updating this unit		
Menu Scroll	Normal / Loop	Select the method for menu scrolling. [Normal]: The cursor moves and stops at the top or the bottom. [Loop]: The cursor continues moving up (jumping from the top to the bottom) or down (jumping from the bottom to the top).
Setting the menu scroll operation		

1) If recording/playback cannot be made with an SxS memory card because it has been operated with a device other than this recorder, or for some other reason, updating the managerial file on the card may improve the situation.

2) When you copy an SxS memory card including multiple clips and files to another card with the same capacity, all the clips and files may not be copied completely to the end, depending on the usage conditions or memory properties.

Connecting External Monitors and Camcorders

To display recording/playback pictures on an external monitor, select the output signal and use an appropriate cable for the monitor to be connected.

Regardless of the 3G, HD, or SD signal, the same status information and menus that appear on the LCD monitor can be displayed on the external monitor. Set [SDI/HDMI/Video Out Super] (page 51) in the [VIDEO SET] menu to [On]. When outputting SD signals in HD Mode, select the output mode in advance using [Down Converter] (page 51) in the [VIDEO SET] menu.

Note

When down-converted SD signals are output, images of 50P/50i/25P are output as PAL signals, images of 59.94P/59.94i/29.97P are output as NTSC signals, and images of 23.98P are output as 2-3 pulled-down NTSC signals.

SDI OUT 1/2 connectors (BNC type)

The following signals are output depending on the 3G/HD/SD setting on the recorder.

- 3G SDI signals
- HD SDI signals (default setting)
- SDI signals

Set [SDI/HDMI/i.LINK I/O Select] (page 50) in the [VIDEO SET] menu to output down-converted SD SDI signals for monitoring, even in HD Mode.

If an HDV or DVCAM stream is being input from the device connected to the i.LINK connector, you can output the input signal on the i.LINK connector from the SDI OUT 1/2 connectors. Use a commercially available 75-ohm coaxial cable for connection.

Note

Support for Level A for 3G SDI signals is planned for future updates.

HDMI OUT connector (Type A connector)

Signal output from this connector is enabled by setting [SDI/HDMI/i.LINK I/O Select] (page 50) in the [VIDEO SET] menu.

In HD Mode, you can select HD HDMI, SD HDMI interlace, or SD HDMI Progressive output.

In SD Mode, only an SD HDMI interlace signal can be output.

Use a commercially available HDMI cable for connection.

VIDEO OUT connector (BNC type)

By changing the setting of [SDI/HDMI/i.LINK I/O Select] (page 50) in the [VIDEO SET] menu, you can output HD-Y signals in HD Mode or down-converted SD analog composite signals for monitoring in SD Mode.

Use a commercially available BNC cable for connection.

i.LINK connector (IEEE1394, 4-pin)

Input/output of an HDV or DVCAM stream can be enabled by changing [SDI/HDMI/i.LINK I/O Select] (page 50) in the [VIDEO SET] menu.

To set the input, select [i.LINK] in [Input Source Select] (page 49) in the [VIDEO SET] menu.

A monitor or VTR that supports i.LINK can be connected (page 68).

AUDIO OUT connector (pin jack)

Outputs the recording audio signal during recording or standby mode, and outputs the playback signal during playback.

By changing the setting of [AUDIO OUTPUT] > [Output CH] in the [AUDIO SET] menu, you can select channels 1 and 2 or channels 3 and 4 for audio output.

Use a commercially available audio cable for connection.

SDI IN Connector (BNC type)

The recorder supports the input of SDI signals (3G SDI/HD SDI/SD SDI), from a camcorder or other device for recording or output to another device.

To set an SDI input signal, select [SDI] in [Input Source Select] in the [VIDEO SET] menu.

Use a commercially available 75-ohm coaxial cable for connection.

To start recording using a trigger signal from an external device

When recording HD SDI signal input, setting [SDI Rec Control] (*page 51*) to [On] in the [VIDEO SET] menu enables the recorder to start recording when a REC trigger signal is received from the device connected to the SDI IN connector.

Notes

- Support for Level A for 3G SDI signals is planned for future updates.
- No operation occurs if the connected external device does not support the REC trigger signal function.

Connecting Audio Equipment

You can input audio signals on channels separate from the video signal by using the AUDIO IN 1/2 connectors on the audio input box. Audio input levels can be adjusted using the audio input level knobs on the audio input box.

AUDIO IN 1/2 connectors (XLR type, 3-pin)

Input audio signals from an audio mixer, or other audio equipment.

Connecting a Computer

When you connect the recorder to a computer using the supplied USB cable, the memory card inserted in the recorder's slot is recognized as an external drive for the computer.

When two memory cards are mounted in this recorder, they are acknowledged as two independent extended drives by the computer.

Notes

- The recorder does not work on the bus power from the computer. Supply the operating power independently.
- When using the ExpressCard slot on a computer, set the SxS card to write protect (i.e., read only), and back up data onto the computer before editing.

To check the connection to the recorder

1 Connect the PC connector on the recorder to the computer using the supplied USB cable, and turn on the recorder.

A message prompting you to confirm that you wish to enable connection with the computer is displayed on the LCD monitor.

Note

This message will not be displayed while another confirmation message or in-progress message (e.g., for formatting or restoration of an SxS memory card) is shown on the screen. It appears when formatting or restoration is completed. The message is also not displayed while the CLIP INFO screen is shown on the screen. It appears when an operation on the CLIP INFO screen is completed or you return to the thumbnail screen.

2 Select [Execute].

3 On Windows, check that the memory card is displayed as a removable disk in My Computer.

On Macintosh, check that a "NO NAME" or "Untitled" folder was created on the desktop. (The Macintosh folder name can be changed.)

If the computer is equipped with an ExpressCard/34 or ExpressCard/54 slot, you can directly insert the SxS memory card to access the files.

Notes

- The following operations must be eliminated when the access lamp is lit in red.

- Turning the power off or disconnecting the power cord
- Removing the SxS memory card
- Disconnecting the USB cable
- When removing an SxS memory card from a Macintosh, do not select "Card Power Off" from the SxS memory card icon displayed on the menu bar.
- Operation is not guaranteed with all computers.
- Use the supplied USB cable for connection.

Connecting via i.LINK

Signals can be input/output on the i.LINK connector when an HDV-compatible video format (SP 1440/59.94i, SP 1440/50i) or when DVCAM in SD mode is selected.

In FAT mode, set “SDI/HDMI/i.LINK I/O Select” to “HD & HDV,” “SD & HDV,” “SD P & HDV,” or “SD & DVCAM” in the VIDEO SET menu. In UDF/SD, set it to “SD.”

You can record the same images as those recorded in this recorder on an external device connected to the i.LINK connector, or record playback pictures from the external device on the recorder.

For playback, DVCAM streams of 16-bit 2-channel lock audio are acceptable.

Nonlinear editing conforming to the HDV format is also enabled.

Notes

- Use the i.LINK connector only for one-to-one i.LINK connection.
- When you change a setting which affects output signals from the i.LINK connector, such as “System” in the OTHERS menu or “SDI/HDMI/i.LINK I/O Select” and “Down Converter” in the VIDEO SET menu, disconnect the i.LINK cable then change the setting. Changing such a setting with the i.LINK cable connected may cause improper operation of the connected i.LINK device.
- An i.LINK connection and USB wireless LAN module cannot be used at the same time. Do not connect an IFU-WLM3 to the external device connector during i.LINK connections.

Recording the Image on an External Device **FAT**

While recording or in standby mode, the image being recorded with this recorder is output as an HDV or DVCAM stream via the i.LINK connector. It can be recorded on a connected HDV or DVCAM recorder in synchronization with the recording operation on this recorder.

1 Perform the preparatory settings of the recorder.

- “SDI/HDMI/i.LINK I/O Select” (page 50) in the VIDEO SET menu
- “Trigger Mode” (page 57) in the OTHERS menu

2 Set the external device to recording standby status.

3 Start recording with the recorder.

The external device starts recording in synchronization.

The status of the external device is displayed in the i.LINK status indication area (page 9) on the LCD monitor.

Indication	Status of the external device
STBY i.HDV	In HDV recording standby
●REC i.HDV	In HDV recording
STBY i.DV	In DV recording standby
●REC i.DV	In DV recording

Notes

- Operation may be different depending on the type of external device.
- There is some time lag from when you start recording until the i.LINK status indication changes. Recording does not start on the connected i.LINK device before it enters synchronization even if [Trigger Mode] is set to [Both].
- While you can insert shot marks on the memory card during recording, they are not added to the pictures recorded on the external device.

Nonlinear Editing **FAT**

When the recorder is in playback mode, you can transfer an HDV stream to a nonlinear editing system connected via the i.LINK connector.

Notes

- The i.LINK connector of this recorder is a 4-pin connector. Check the number of pins of the i.LINK connector on your computer and use an appropriate i.LINK cable.
- In searching pictures of this recorder on the computer, it may take some time until the display is reflected on the computer.
- If the playback clip is short or the playback starting point is near the end of the clip, the i.LINK signal may be interrupted between the clip and the next clip. When you try to capture such a signal using the nonlinear editing system, a malfunction may occur, depending on the nonlinear editing software in use.
- If you specify a search speed other than 4, 15, or 24 times normal with the nonlinear editing system, no i.LINK signal is fed out. In such a case, the picture on the LCD monitor may stay frozen.
- High-speed playback picture may not be displayed on the computer screen, depending on the nonlinear editing software in use.

Setting on this recorder

Set [SDI/HDMI/i.LINK I/O Select] (page 50) in the [VIDEO SET] menu to [HD & HDV], [SD & HDV], [SD P & HDV], or [SD & DVCAM].

Recording and SDI Output of External Input Signals

The recorder supports HDV or DVCAM stream input from a device connected to the i.LINK connector, and output to a device connected to the SDI OUT connector. Input signals can also be recorded on SxS memory cards in the recorder. The timecode superimposed on the i.LINK input is recorded.

1 Set the external signal to a format supported by the recorder.

1440 × 1080/59.94i, 1440 × 1080/50i, and DVCAM input formats are supported.

2 In FAT mode, set [SDI/HDMI/i.LINK I/O Select] (page 50) to [HD & HDV], [SD & HDV], [SD P & HDV], or [SD & DVCAM] in the [VIDEO SET] menu. In UDF/SD mode, set it to [SD].

3 Set [Input Source Select] (page 49) to [i.LINK] in the [VIDEO SET] menu.

The input signal is output from the SDI OUT 1/2 connectors.

The video signal is output on the VIDEO OUT connector and the LCD monitor. The audio signal is output on the AUDIO OUT connector, headphone connector, and built-in speaker.

4 To record, press and hold the REC button, then press the PLAY/PAUSE button.

Notes

- An error is displayed if any of the following conditions occur during recording. When an error is displayed, press the STOP/EE button to stop recording.
 - The video format of the input signal is different to the recorder format setting.
 - A copy-prohibited stream is input.
- If the input signal to the recorder during recording is lost, the tally lamp and the “●REC” i.LINK status indication on the LCD monitor start flashing, indicating that nothing is being recorded on the SxS memory card.

Recording resumes when the signal is restored, but the clip number on the recorder is incremented.

- During DVCAM streams, images and audio may skip or repeat after consecutive operations during DVCAM streams due to CLK frequency differences between the DVCAM signal source and recorder.
- During HDV streams, the recorder operates as if locked to the input HDV signals. Therefore, frequency shifts in the signal source may cause deviations from the SDI output signal standards (frequency, jitter, etc.)

Connecting USB Media

You can connect USB storage media (such as a HDD or flash memory) to the external device connector of the recorder to copy clips between SxS memory cards and USB media.

Supported USB Media

USB media that can be used with this unit must satisfy the following criteria.

Capacity: 3 GB to 2 TB

Media with capacity less than 3 GB is not recognized. Media with capacity exceeding 2 TB is recognized as 2 TB media.

Format: exFAT

Only media formatted on the PMW-50, PMW-400, PMW-1000 or this unit can be used. Media formatted using other devices may not operate correctly.

The recommended USB media are as follows.

- Sony PSZ-HA1T (1 TB)
- Sony PSZ-HA50 (500 GB)
- Sony PSZ-SA25 (256 GB)
- Sony HD-E1 (1 TB)
- Sony HD-EG5 (500 GB)

The operation of the following USB media has been verified.

- Lacie LCH-RG005T3 (500 GB)
- Buffalo HD-PNT2.0U3-GBC (2 TB)

When valid USB media is connected, the USB icon (*page 9*) is displayed on the LCD monitor.

Notes

- The correct operation of HDD or USB flash drives that meet the above criteria is not guaranteed.
- This unit is compatible with USB media that operates from a 5.0 V / 0.5 A power source. The unit may not recognize the USB media, depending on the media used. In such cases, supply a separate power source.
- Input signals cannot be recorded directly to USB media.
- Do not disconnect USB media while copying or playing back clips on the media.

Copying Clips

To copy from SxS memory cards to USB media

Copy clips recorded on SxS memory cards to USB media by selecting [USB SET] > [Copy To USB] in the [OTHERS] menu when the thumbnail screen is displayed.

The copy destination folder is specified using [USB SET] > [Select Folder] in the [OTHERS] menu. If no folder is selected, a new folder is created and files are copied to it. The name of the new folder uses the recording date of the first clip on the source SxS memory card. If [A&B → USB] is selected, clips on the selected SxS memory card are saved in the folder specified using [Select Folder], and clips on the unselected SxS memory card are saved in a new folder. You can also copy clips by selecting them on the thumbnail screen. Select the clips and then select [COPY CLIP(A)] or [COPY CLIP(B)] from the Clip Operation menu.

To copy all clips using an assignable button

Assign the [Quick Backup] function to an assignable switch, then press the assignable button to copy all clips on the selected SxS memory card to USB media.

A new folder is created and files are copied to it.

To copy from USB media to SxS memory cards

Copy clips recorded on USB media to the selected SxS memory card by selecting [USB SET] > [Copy From USB] in the [OTHERS] menu when the thumbnail screen is displayed.

Error checking

You can turn on error checking when copying clips between USB media and SxS memory cards by setting [USB SET] > [Error Check] to [On] in the [OTHERS] menu. If an error message appears, try copying the clip again. Copying with error checking enabled takes approximately twice the time as when error checking is disabled.

Displaying the USB Media Thumbnail Screen

Select [USB SET] > [Thumbnail View] in the [OTHERS] menu to display the thumbnail screen for clips recorded on USB media. You can also assign the [USB Thumbnail View] function to an

assignable button, then press the button to display the USB media thumbnail screen.

The operations that can be performed on the USB media thumbnail screen are basically the same as those for the SxS memory card thumbnail screen, although with the following differences.

- Functions that are not available
 - Adding and deleting shot marks
 - Adding and deleting OK/NG/KP flags and OK marks
 - Setting index pictures
 - Splitting clips
- Dropped frames and other issues may occur when playing back clips recorded on USB media.

Clip Operation menu

Item	Function
DISP CLIP INFO	Displays the clip detailed information screen (<i>page 38</i>).
COPY CLIP(A)	Copies the selected clips to the SxS memory card in slot A or slot B (<i>page 39</i>).
COPY CLIP(B)	
DELETE CLIP	Deletes the clip (<i>page 39</i>).
EXPAND CLIP	Displays the EXPAND CLIP screen (<i>page 39</i>).
CLIP REPEAT	Plays the selected clip repeatedly (<i>page 35</i>).

Important Notes on Operation

Use and storage

Do not subject the unit to severe shock

The internal mechanism may be damaged or the body warped.

Do not cover the unit while operating

Putting a cloth, for example, over the unit can cause excessive internal heat build-up.

After use

Always turn the power OFF.

Before storing the unit for a long period

Remove the battery pack.

When carrying

If you carry it by the LCD monitor block, the recorder may drop, causing damage.

Shipping

- Remove the memory cards before transporting the unit.
- If sending the unit by truck, ship, air or other transportation service, pack it in the shipping carton of the unit.

Care of the unit

If the body of the unit is dirty, clean it with a soft, dry cloth. In extreme cases, use a cloth steeped in a little neutral detergent, then wipe dry. Do not use organic solvents such as alcohol or thinner, as these may cause discoloration or other damage to the finish of the unit.

In the event of operating problems

If you should experience problems with the unit, contact your Sony dealer.

Note about the battery terminal

The battery terminal of this unit (the connector for battery packs and AC adaptors) is a consumable part.

Power may not be supplied to the unit properly if the pins of the battery terminal are bent or deformed by shock or vibrations, or if they become corroded due to prolonged outdoor use.

Periodic inspections are recommended to keep the unit working properly and to prolong its usable lifetime.

Contact a Sony service or sales representative for more information about inspections.

Use and storage locations

Store in a level, ventilated place. Avoid using or storing the unit in the following places:

- In excessive heat or cold (operating temperature range: 0 °C to 40 °C or 32 °F to 104 °F)
Remember that in summer in warm climates the temperature inside a car with the windows closed can easily exceed 50 °C (122 °F).
- In damp or dusty locations
- Locations where the unit may be exposed to rain
- Locations subject to violent vibration
- Near strong magnetic fields
- Close to radio or TV transmitters producing strong electromagnetic fields.
- In direct sunlight or close to heaters for extended periods

To prevent electromagnetic interference from portable communications devices

The use of portable telephones and other communications devices near this unit can result in malfunctions and interference with audio and video signals.

It is recommended that the portable communications devices near this unit be powered off.

Condensation

If the unit is suddenly taken from a cold to a warm location, or if ambient temperature suddenly rises, moisture may form on the outer surface of the unit and/or inside of the unit. This is known as condensation. If condensation occurs, turn off the unit and wait until the condensation clears before operating the unit. Operating the unit while condensation is present may damage the unit.

About the LCD panels

The LCD panel fitted to this unit is manufactured with high precision technology, giving a

functioning pixel ratio of at least 99.99%. Thus a very small proportion of pixels may be “stuck”, either always off (black), always on (red, green, or blue), or flashing. In addition, over a long period of use, because of the physical characteristics of the liquid crystal display, such “stuck” pixels may appear spontaneously. These problems are not a malfunction. Note that any such problems have no effect on recorded data.

Notes about the display

- Pictures on the LCD monitor may be distorted by the following operations:
 - Changing the video format
 - Starting playback from the Thumbnail screen
 - Reversing the LCD monitor

File fragmentation

If pictures cannot be recorded/reproduced properly, try formatting the recording medium. While repeating picture recording/playback with a certain recording medium for an extended period, files in the medium may be fragmented, disabling proper recording/storage. In such a case, make a backup of clips in the medium then perform formatting of the medium using [Format Media] (*page 60*) in the [OTHERS] menu.

Consumable parts

The fan and battery are consumable parts that will need periodic replacement.

When operating at room temperature, a normal replacement cycle will be about 5 years. However, this replacement cycle represents only a general guideline and does not imply that the life expectancy of these parts is guaranteed. For details on parts replacement, contact your dealer.

AC adapter and electrolytic capacitor

The life expectancy of the AC adapter and the electrolytic capacitor is about 5 years under normal operating temperatures and normal usage (8 hours per day; 25 days per month). If usage exceeds the above normal usage frequency, the life expectancy may be reduced correspondingly.

Batteries

i) For safety, use only the Sony battery packs and AC adaptors listed below.

BP-U30/BP-U60/BP-U90/BP-U60

ii) The battery terminal of this unit (the connector for battery packs and AC adaptors) is a consumable part.

Power may not be supplied to the unit properly if the pins of the battery terminal are bent or deformed by shock or vibrations, or if they become corroded due to prolonged outdoor use.

Periodic inspections are recommended to keep the unit working properly and to prolong its usable lifetime.

Contact a Sony service or sales representative for more information about inspections.

Recording Video Formats ([Rec Format])

The video formats for recording that are selectable in the [OTHERS] >[System] >[Rec Format] setup menu are as follows.

The default settings set at the factory are shown in bold face (example: **HD422 50/1080/59.94i**).

UDF/HD mode

[Country] settings	Selectable recording video formats
[NTSC Area] or [NTSC (J) Area]	HD 422 50/1080/59.94i HQ 1920×1080/59.94i HQ 1440×1080/59.94i HD 422 50/1080/29.97P HQ 1920×1080/29.97P HQ 1440×1080/29.97P HD 422 50/1080/23.98P HQ 1920×1080/23.98P HQ 1440×1080/23.98P HD 422 50/720/59.94P HQ 1280×720/59.94P
[PAL Area]	HD 422 50/1080/50i HQ 1920×1080/50i HQ 1440×1080/50i HD 422 50/1080/25P HQ 1920×1080/25P HQ 1440×1080/25P HD 422 50/720/50P HQ 1280×720/50P

UDF/SD mode

[Country] settings	Selectable recording video formats
[NTSC Area] or [NTSC (J) Area]	DVCAM59.94i IMX50 59.94i
[PAL Area]	DVCAM50i IMX50 50i

exFAT/HD mode

[Country] settings	MXF file format	Selectable recording video formats
[NTSC Area] or [NTSC (J) Area]	XAVC	XAVC-I 1080/59.94P XAVC-L50 1080/59.94P XAVC-L35 1080/59.94P XAVC-I 1080/59.94i XAVC-L50 1080/59.94i XAVC-L35 1080/59.94i XAVC-L25 1080/59.94i XAVC-I 1080/29.97P XAVC-L50 1080/29.97P XAVC-L35 1080/29.97P XAVC-I 1080/23.98P XAVC-L50 1080/23.98P XAVC-L35 1080/23.98P XAVC-I 720/59.94P XVAC-L50 720/59.94P
	MPEG2	HD 422 50/1080/59.94i HQ 1920×1080/59.94i HQ 1440×1080/59.94i HD 422 50/1080/29.97P HQ 1920×1080/29.97P HQ 1440×1080/29.97P HD 422 50/1080/23.98P HQ 1920×1080/23.98P HQ 1440×1080/23.98P HD 422 50/720/59.94P HQ 1280×720/59.94P
[PAL Area]	XAVC	XAVC-I 1080/50P XAVC-L50 1080/50P XAVC-L35 1080/50P XAVC-I 1080/50i XAVC-L50 1080/50i XAVC-L35 1080/50i XAVC-L25 1080/50i XAVC-I 1080/25P XAVC-L50 1080/25P XAVC-L35 1080/25P XAVC-I 720/50P XAVC-L50 720/50P
	MPEG2	HD422 50/1080/50i HQ 1920×1080/50i HQ 1440×1080/50i HD 422 50/1080/25P HQ 1920×1080/25P HQ 1440×1080/25P HD 422 50/720/50P HQ 1280×720/50P

exFAT/SD mode

[Country] settings	Selectable recording video formats
[NTSC Area] or [NTSC (J) Area]	DVCAM 59.94i IMX50 59.94i
[PAL Area]	DVCAM 50i IMX50 50i

FAT/HD mode

[Country] settings	Selectable recording video formats
[NTSC Area] or [NTSC (J) Area]	HQ 1920×1080/59.94i HQ 1440×1080/59.94i SP 1440×1080/59.94i HQ 1920×1080/29.97P HQ 1440×1080/29.97P HQ 1920×1080/23.98P HQ 1440×1080/23.98P HQ 1280×720/59.94P
[PAL Area]	HQ 1920×1080/50i HQ 1440×1080/50i SP 1440×1080/50i HQ 1920×1080/25P HQ 1440×1080/25P HQ 1280×720/50P

FAT/SD mode

[Country] settings	Selectable recording video formats
[NTSC Area] or [NTSC (J) Area]	DVCAM59.94i
[PAL Area]	DVCAM50i

Formats and Limitations of Outputs

SDI OUT 1/2 Connector Output Formats

Recording/standby (SDI input) (when [SDI/HDMI/i.LINK I/O Select] is [3G (SDI)])

Input format		Output format
[Rec Format] in [System] in [OTHERS] menu	SDI IN	[SDI/HDMI/i.LINK I/O Select] in [VIDEO SET] menu
		3G (SDI)
59.94P (XAVC-I/XAVC-L)	1920×1080/59.94P	1920×1080/59.94P
59.94i (XAVC-I/XAVC-L/HD/HQ)	1920×1080/59.94i	1920×1080/59.94i
29.97P (XAVC-I/XAVC-L/HD/HQ)		
23.98P (XAVC-I/XAVC-L/HD/HQ)	1920×1080/23.98PsF	1920×1080/59.94i ¹⁾ 1920×1080/23.98PsF ²⁾
59.94P (XAVC-I/XAVC-L/HD/HQ)	1280×720/59.94P	1280×720/59.94P
50P (XAVC-I/XAVC-L)	1920×1080/50P	1920×1080/50P
50i (XAVC-I/XAVC-L/HD/HQ)	1920×1080/50i	1920×1080/50i
25P (XAVC-I/XAVC-L/HD/HQ)		
50P (XAVC-I/XAVC-L/HD/HQ)	1280×720/50P	1280×720/50P

Recording/standby (SDI input)

Input format		Output format		
[Rec Format] in [System] in [OTHERS] menu	SDI IN	[SDI/HDMI/i.LINK I/O Select] in [VIDEO SET] menu		
		HD/HD & HDV	SD/SD & HDV/ SD & DVCAM	SD P/SD P & HDV
59.94P (XAVC-I/XAVC-L)	1920×1080/59.94P	1920×1080/59.94i ³⁾	SD 59.94i ³⁾	N/A
59.94i (XAVC-I/XAVC-L/HD/HQ/SP)	1920×1080/59.94i	1920×1080/59.94i	SD 59.94i	
29.97P (XAVC-I/XAVC-L/HD/HQ)				
23.98P (XAVC-I/XAVC-L/HD/HQ)	1920×1080/23.98PsF	1920×1080/59.94i ¹⁾ 1920×1080/23.98PsF ²⁾		
59.94P (XAVC-I/XAVC-L/HD/HQ)	1280×720/59.94P	1280×720/59.94P	SD 59.94i ³⁾	
59.94i (DVCAM/IMX)	SD/59.94i	N/A	SD 59.94i	
50P (XAVC-I/XAVC-L)	1920×1080/50P	1920×1080/50i ⁴⁾	SD 50i ⁴⁾	
50i (XAVC-I/XAVC-L/HD/HQ/SP)	1920×1080/50i	1920×1080/50i	SD 50i	
25P (XAVC-I/XAVC-L/HD/HQ)				
50P (XAVC-I/XAVC-L/HD/HQ)	1280×720/50P	1280×720/50P	SD 50i ⁴⁾	
50i (DVCAM/IMX)	SD/50i	N/A	SD 50i	

¹⁾ When [23.98P OUTPUT] is set to [59.94i (2-3 Pull Down)] in the [VIDEO SET] menu

²⁾ When [23.98P OUTPUT] is set to [23.98PsF] in the [VIDEO SET] menu

³⁾ Converted from 59.94P to 59.94i

⁴⁾ Converted from 50P to 50i

Recording/standby (i.LINK (HDV) input)

Enabled in FAT mode only (i.LINK disabled in UDF and exFAT).

When [Rec Format] in [System] is set to [SP 1440/59.94i] in the [OTHERS] menu, the output format is as follows, according to the setting of

[SDI/HDMI/i.LINK I/O Select] in the [VIDEO SET] menu.

HD & HDV: 1920×1080/59.94i

SD & HDV: SD 59.94i

When [Rec Format] in [System] is set to [SP 1440/50i] in the [OTHERS] menu, the output format is as follows, according to the setting of [SDI/HDMI/i.LINK I/O Select] in the [VIDEO SET] menu.

HD & HDV: 1920×1080/50i

SD & HDV: SD 50i

In all other cases, a blue screen is output or the setting is disabled.

Recording/standby (i.LINK (DVCAM) input)

Enabled in FAT mode, UDF/SD mode only (i.LINK disabled in UDF/HD mode and exFAT mode).

When [SDI/HDMI/i.LINK I/O Select] is set to [SD & DVCAM] (FAT mode) or [SD] (UDF/SD mode) in the [VIDEO SET] menu, the output format is set to “SD 59.94i/SD 50i” regardless of the input format.

When [SDI/HDMI/i.LINK I/O Select] is set to other values, a blue screen is output or the setting is disabled.

Playback (when [SDI/HDMI/i.LINK I/O Select] is [3G (SDI)])

Playback clip format	Output format
	[SDI/HDMI/i.LINK I/O Select] in [VIDEO SET] menu
	3G (SDI)
59.94P (XAVC-I/XAVC-L)	1920×1080/59.94P
59.94i (XAVC-I/XAVC-L/HD/HQ)	1920×1080/59.94i
29.97P (XAVC-I/XAVC-L/HD/HQ)	1920×1080/59.94i 1280×720/59.94P ¹⁾
23.98P (XAVC-I/XAVC-L/HD/HQ)	1920×1080/59.94i ²⁾ 1920×1080/23.98PsF ³⁾ 1280×720/59.94P ¹⁾
59.94P (XAVC-I/XAVC-L/HD/HQ)	1280×720/59.94P
50P (XAVC-I/XAVC-L)	1920×1080/50P
50i (XAVC-I/XAVC-L/HD/HQ)	1920×1080/50i
25P (XAVC-I/XAVC-L/HD/HQ)	1920×1080/50i 1280×720/50P ¹⁾
50P (XAVC-I/XAVC-L/HD/HQ)	1280×720/50P

Playback

Playback clip format	Output format		
	[SDI/HDMI/i.LINK I/O Select] in [VIDEO SET] menu		
	HD/HD & HDV	SD/SD & HDV/ SD & DVCAM	SD P/SD P & HDV
59.94P (XAVC-I/XAVC-L)	1920×1080/59.94i ⁵⁾	SD 59.94i ⁵⁾	N/A
59.94i (XAVC-I/XAVC-L/HD/HQ/SP)	1920×1080/59.94i	SD 59.94i	
29.97P (XAVC-I/XAVC-L/HD/HQ)	1920×1080/59.94i 1280×720/59.94P ¹⁾		
23.98P (XAVC-I/XAVC-L/HD/HQ)	1920×1080/59.94i ²⁾ 1920×1080/23.98PsF ³⁾ 1280×720/59.94P ¹⁾		
59.94P (XAVC-I/XAVC-L/HD/HQ)	1280×720/59.94P	SD 59.94i ⁵⁾	
59.94i (DVCAM/IMX)	N/A	SD 59.94i	
50P (XAVC-I/XAVC-L)	1920×1080/50i ⁶⁾	SD 50i ⁶⁾	
50i (XAVC-I/XAVC-L/HD/HQ/SP)	1920×1080/50i	SD 50i	
25P (XAVC-I/XAVC-L/HD/HQ)	1920×1080/50i 1280×720/50P ¹⁾		
50P (XAVC-I/XAVC-L/HD/HQ)	1280×720/50P	SD 50i ⁶⁾	
50i (DVCAM/IMX)	N/A	SD 50i	

1) When the playback clip format is 720

- 2) When [23.98P OUTPUT] is set to [59.94i (2-3 Pull Down)] in the [VIDEO SET] menu and the playback clip format is 1080
- 3) When [23.98P OUTPUT] is set to [23.98PsF] in the [VIDEO SET] menu and the playback clip format is 1080

- 4) When the playback clip format is 720. Also, pulldown playback occurs automatically when playing a Pure P clip recorded in FAT/HQ1280/23.98P.
- 5) Converted from 59.94P to 59.94i
- 6) Converted from 50P to 50i

On thumbnail screens (when [SDI/HDMI/i.LINK I/O Select] is [3G (SDI)])

Input format	Output format
[Rec Format] in [System] in [OTHERS] menu	[SDI/HDMI/i.LINK I/O Select] in [VIDEO SET] menu
	3G (SDI)
59.94P (XAVC-I/XAVC-L)	1920×1080/59.94i ³⁾
59.94i (XAVC-I/XAVC-L/HD/HQ)	1920×1080/59.94i
29.97P (XAVC-I/XAVC-L/HD/HQ)	
23.98P (XAVC-I/XAVC-L/HD/HQ)	1920×1080/59.94i ¹⁾ 1920×1080/23.98PsF ²⁾
59.94P (XAVC-I/XAVC-L/HD/HQ)	1280×720/59.94P
50P (XAVC-I/XAVC-L)	1920×1080/50i ⁴⁾
50i (XAVC-I/XAVC-L/HD/HQ)	1920×1080/50i
25P (XAVC-I/XAVC-L/HD/HQ)	
50P (XAVC-I/XAVC-L/HD/HQ)	1280×720/50P

On thumbnail screens

[Rec Format] in [System] in [OTHERS] menu	Output format		
	[SDI/HDMI/i.LINK I/O Select] in [VIDEO SET] menu		
	HD/HD & HDV	SD/SD & HDV/ SD & DVCAM	SD P/SD P & HDV
59.94P (XAVC-I/XAVC-L)	1920×1080/59.94i ³⁾	SD 59.94i ³⁾	N/A
59.94i (XAVC-I/XAVC-L/HD/HQ/SP)	1920×1080/59.94i	SD 59.94i	
29.97P (XAVC-I/XAVC-L/HD/HQ)			
23.98P (XAVC-I/XAVC-L/HD/HQ)	1920×1080/59.94i ¹⁾ 1920×1080/23.98PsF ²⁾		
59.94P (XAVC-I/XAVC-L/HD/HQ)	1280×720/59.94P	SD 59.94i ³⁾	
59.94i (DVCAM/IMX)	N/A	SD 59.94i	
50P (XAVC-I/XAVC-L)	1920×1080/50i ⁴⁾	SD 50i ⁴⁾	
50i (XAVC-I/XAVC-L/HD/HQ/SP)	1920×1080/50i	SD 50i	
25P (XAVC-I/XAVC-L/HD/HQ)			
50P (XAVC-I/XAVC-L/HD/HQ)	1280×720/50P	SD 50i ⁴⁾	
50i (DVCAM/IMX)	N/A	SD 50i	

- 1) When [23.98P OUTPUT] is set to [59.94i (2-3 Pull Down)] in the [VIDEO SET] menu
- 2) When [23.98P OUTPUT] is set to [23.98PsF] in the [VIDEO SET] menu
- 3) Converted from 59.94P to 59.94i
- 4) Converted from 50P to 50i

HDMI OUT Connector Output Formats

Recording/standby (SDI input) (when [SDI/HDMI/i.LINK I/O Select] is [3G (SDI)])

Input format	Output format
[Rec Format] in [System] in [OTHERS] menu	[SDI/HDMI/i.LINK I/O Select] in [VIDEO SET] menu
SDI IN	3G (SDI)
59.94P (XAVC-I/XAVC-L)	1920×1080/59.94P
59.94i (XAVC-I/XAVC-L/HD/HQ)	1920×1080/59.94i
29.97P (XAVC-I/XAVC-L/HD/HQ)	
23.98P (XAVC-I/XAVC-L/HD/HQ)	1920×1080/23.98PsF
59.94P (XAVC-I/XAVC-L/HD/HQ)	1280×720/59.94P
50P (XAVC-I/XAVC-L)	1920×1080/50P
50i (XAVC-I/XAVC-L/HD/HQ)	1920×1080/50i
25P (XAVC-I/XAVC-L/HD/HQ)	
50P (XAVC-I/XAVC-L/HD/HQ)	1280×720/50P

Recording/standby (SDI input)

Input format	Output format			
[Rec Format] in [System] in [OTHERS] menu	[SDI/HDMI/i.LINK I/O Select] in [VIDEO SET] menu			
SDI IN	HD/HD & HDV	SD/SD & HDV/SD & DVCAM	SD P/SD P & HDV	
59.94P (XAVC-I/XAVC-L)	1920×1080/59.94P	1920×1080/59.94i ³⁾	SD 59.94i ³⁾	SD 59.94P
59.94i (XAVC-I/XAVC-L/HD/HQ/SP)	1920×1080/59.94i	1920×1080/59.94i	SD 59.94i	SD 59.94P ²⁾
29.97P (XAVC-I/XAVC-L/HD/HQ)				SD 59.94P
23.98P (XAVC-I/XAVC-L/HD/HQ)	1920×1080/23.98PsF	1920×1080/59.94i ¹⁾		
59.94P (XAVC-I/XAVC-L/HD/HQ)	1280×720/59.94P	1280×720/59.94P	SD 59.94i ³⁾	
59.94i (DVCAM/IMX)	SD/59.94i	N/A	SD 59.94i	N/A
50P (XAVC-I/XAVC-L)	1920×1080/50P	1920×1080/50i ³⁾	SD 50i ³⁾	SD 50P
50i (XAVC-I/XAVC-L/HD/HQ/SP)	1920×1080/50i	1920×1080/50i	SD 50i	SD 50P ²⁾
25P (XAVC-I/XAVC-L/HD/HQ)				SD 50P
50P (XAVC-I/XAVC-L/HD/HQ)	1280×720/50P	1280×720/50P	SD 50i ³⁾	
50i (DVCAM/IMX)	SD/50i	N/A	SD 50i	N/A

1) When [23.98P OUTPUT] is set to [59.94i (2-3 Pull Down)] in the [VIDEO SET] menu

2) Converted from interlaced to progressive

3) Converted from progressive to interlaced

Recording/standby (i.LINK (HDV) input)

Enabled in FAT mode only (i.LINK disabled in UDF and exFAT).

When [Rec Format] in [System] is set to [SP 1440/59.94i] in the [OTHERS] menu, the output format is as follows.

HD & HDV: 1920×1080/59.94i

SD & HDV: SD 59.94i

SD P & HDV: SD 59.94P

When [Rec Format] in [System] is set to [SP 1440/50i] in the [OTHERS] menu, the output format is as follows.

HD & HDV: 1920×1080/50i

SD & HDV: SD 50i

SD P & HDV: SD 50P

In all other cases, a blue screen is output or the setting is disabled.

Recording/standby (i.LINK (DVCAM) input)

Enabled in FAT mode, UDF/SD mode only (i.LINK disabled in UDF/HD mode and exFAT mode).

When [SDI/HDMI/i.LINK I/O Select] is set to [SD & DVCAM] (FAT mode) or [SD] (UDF/SD

mode) in the [VIDEO SET] menu, the output format is set to “SD 59.94i/SD 50i” regardless of the input format.

When [SDI/HDMI/i.LINK I/O Select] is set to other values, a blue screen is output or the setting is disabled.

Playback (when [SDI/HDMI/i.LINK I/O Select] is [3G (SDI)])

Playback clip format	Output format
	[SDI/HDMI/i.LINK I/O Select] in [VIDEO SET] menu 3G (SDI)
59.94P (XAVC-I/XAVC-L)	1920×1080/59.94i ⁵⁾
59.94i (XAVC-I/XAVC-L/HD/HQ)	1920×1080/59.94i
29.97P (XAVC-I/XAVC-L/HD/HQ)	1920×1080/59.94i 1280×720/59.94P ¹⁾
23.98P (XAVC-I/XAVC-L/HD/HQ)	1920×1080/59.94i ²⁾ 1280×720/59.94P ³⁾
59.94P (XAVC-I/XAVC-L/HD/HQ)	1280×720/59.94P
50P (XAVC-I/XAVC-L)	1920×1080/50i ⁵⁾
50i (XAVC-I/XAVC-L/HD/HQ)	1920×1080/50i
25P (XAVC-I/XAVC-L/HD/HQ)	1920×1080/50i 1280×720/50P ¹⁾
50P (XAVC-I/XAVC-L/HD/HQ)	1280×720/50P

Playback

Playback clip format	Output format		
	[SDI/HDMI/i.LINK I/O Select] in [VIDEO SET] menu		
	HD/HD & HDV	SD/SD & HDV/ SD & DVCAM	SD P/SD P & HDV
59.94P (XAVC-I/XAVC-L)	1920×1080/59.94i ⁵⁾	SD 59.94i ⁵⁾	SD 59.94P
59.94i (XAVC-I/XAVC-L/HD/HQ/SP)	1920×1080/59.94i	SD 59.94i	SD 59.94P ⁴⁾
29.97P (XAVC-I/XAVC-L/HD/HQ)	1920×1080/59.94i 1280×720/59.94P ¹⁾		SD 59.94P
23.98P (XAVC-I/XAVC-L/HD/HQ)	1920×1080/59.94i ¹⁾ 1280×720/59.94P ³⁾		
59.94P (XAVC-I/XAVC-L/HD/HQ)	1280×720/59.94P	SD 59.94i ⁵⁾	
59.94i (DVCAM/IMX)	N/A	SD 59.94i	N/A
50P (XAVC-I/XAVC-L)	1920×1080/50i ⁵⁾	SD 50i ⁵⁾	SD 50P
50i (XAVC-I/XAVC-L/HD/HQ/SP)	1920×1080/50i	SD 50i	SD 50P ⁴⁾
25P (XAVC-I/XAVC-L/HD/HQ)	1920×1080/50i 1280×720/50P ¹⁾		SD 50P
50P (XAVC-I/XAVC-L/HD/HQ)	1280×720/50P	SD 50i ⁵⁾	
50i (DVCAM/IMX)	N/A	SD 50i	N/A

- 1) When the playback clip format is 720
- 2) When [23.98P OUTPUT] is set to [59.94i (2-3 Pull Down)] in the [VIDEO SET] menu and the playback clip format is 1080
- 3) When the playback clip format is 720. Also, pulldown playback occurs automatically when playing a clip recorded in Pure P.
- 4) Converted from interlaced to progressive
- 5) Converted from progressive to interlaced

On thumbnail screens (when [SDI/HDMI/i.LINK I/O Select] is [3G (SDI)])

Input format	Output format
[Rec Format] in [System] in [OTHERS] menu	[SDI/HDMI/i.LINK I/O Select] in [VIDEO SET] menu
	3G (SDI)
59.94P (XAVC-I/XAVC-L)	1920×1080/59.94i ³⁾
59.94i (XAVC-I/XAVC-L/HD/HQ)	1920×1080/59.94i
29.97P (XAVC-I/XAVC-L/HD/HQ)	
23.98P (XAVC-I/XAVC-L/HD/HQ)	1920×1080/59.94i ¹⁾
59.94P (XAVC-I/XAVC-L/HD/HQ)	1280×720/59.94P
50P (XAVC-I/XAVC-L)	1920×1080/50i ³⁾
50i (XAVC-I/XAVC-L/HD/HQ)	1920×1080/50i
25P (XAVC-I/XAVC-L/HD/HQ)	
50P (XAVC-I/XAVC-L/HD/HQ)	1280×720/50P

On thumbnail screens

[Rec Format] in [System] in [OTHERS] menu	Output format		
	[SDI/HDMI/i.LINK I/O Select] in [VIDEO SET] menu		
	HD/HD & HDV	SD/SD & HDV/ SD & DVCAM	SD P/SD P & HDV
59.94P (XAVC-I/XAVC-L)	1920×1080/59.94i ³⁾	SD 59.94i ³⁾	SD 59.94P
59.94i (XAVC-I/XAVC-L/HD/HQ/SP)	1920×1080/59.94i	SD 59.94i	SD 59.94P ²⁾
29.97P (XAVC-I/XAVC-L/HD/HQ)			SD 59.94P
23.98P (XAVC-I/XAVC-L/HD/HQ)			
59.94P (XAVC-I/XAVC-L/HD/HQ)	1280×720/59.94P	SD 59.94i ³⁾	
59.94i (DVCAM/IMX)	N/A	SD 59.94i	N/A
50P (XAVC-I/XAVC-L)	1920×1080/50i ³⁾	SD 50i ³⁾	SD 50P
50i (XAVC-I/XAVC-L/HD/HQ/SP)	1920×1080/50i	SD 50i	SD 50P ²⁾
25P (XAVC-I/XAVC-L/HD/HQ)			SD 50P
50P (XAVC-I/XAVC-L/HD/HQ)			
50P (XAVC-I/XAVC-L/HD/HQ)	1280×720/50P	SD 50i ³⁾	
50i (DVCAM/IMX)	N/A	SD 50i	N/A

¹⁾ When [23.98P OUTPUT] is set to [59.94i (2-3 Pull Down)] in the [VIDEO SET] menu

²⁾ Converted from interlaced to progressive

³⁾ Converted from progressive to interlaced

VIDEO OUT Connector Output Formats

Recording/standby (SDI input)

In SDI input mode, formats are the same as the SDI OUT 1/2 connectors output formats.

Recording/standby (i.LINK (HDV) input)

In i.LINK (HDV) input mode, formats are the same as the SDI OUT 1/2 connectors output formats.

Recording/standby (i.LINK (DVCAM) input)

In i.LINK (DVCAM) input mode, formats are the same as the SDI OUT 1/2 connectors output formats.

Playback

Formats are the same as the SDI OUT 1/2 connectors output formats.

On thumbnail screens

In SDI input mode, formats are the same as the SDI OUT 1/2 connector output formats.

Note

When [VIDEO SET] > [SDI/HDMI/i.LINK I/O Select] is set to [3G (SDI)] in the setup menu, the same output format used during HD will be used.

i.LINK Connector Output Formats

Recording/standby (SDI input)

Enabled in FAT mode only (i.LINK disabled in

UDF and exFAT).

When [Country] is set to [NTSC Area] or [NTSC(J) Area], and [Rec Format] is set to [SP 1440/59.94i] in [System] in the [OTHERS] menu, the output format is as follows.

*** & HDV: HDV 59.94i

*** & DVCAM: SD 59.94i

When [Country] is set to [NTSC Area] or [NTSC(J) Area], and [Rec Format] is not set to [SP 1440/59.94i] in [System] in the [OTHERS] menu, the output format is as follows.

*** & HDV: N/A

*** & DVCAM: SD 59.94i (1920×1080/23.98P and 1440×1080/23.98P: N/A)

When [Country] is set to [PAL Area] and [Rec Format] is set to [SP 1440/59.94i] in [System] in the [OTHERS] menu, the output format is as follows.

*** & HDV: HDV 50i

*** & DVCAM: SD 50i

When [Country] is set to [PAL Area] and [Rec Format] is not set to [SP 1440/59.94i] in [System] in the [OTHERS] menu, the output format is as follows.

*** & HDV: N/A

*** & DVCAM: SD 50i

Playback

Enabled in FAT mode and UDF/SD mode only (i.LINK disabled in UDF/HD and exFAT).
When the playback clip format is set to [SP 1440/59.94i], with [Country] set to [NTSC Area] or [NTSC(J) Area] and [Rec Format] set to [SP 1440/59.94i] in [System] in the [OTHERS] menu, the output format is as follows.

*** & HDV: HDV 59.94i

*** & DVCAM: DVCAM 59.94i

When a clip with a different format than that above is played, with [Country] set to [NTSC Area] or [NTSC(J) Area], the output format is as follows.

*** & HDV: N/A

*** & DVCAM: DVCAM 59.94i
(1920×1080/23.98P, 1440×1080/23.98P,
1280×720/23.98P: N/A)

SD: DVCAM 59.94i (UDF/SD mode)

When the playback clip format is set to [SP 1440/50i], with [Country] set to [PAL Area] and [Rec Format] set to [SP 1440/50i] in [System] in the [OTHERS] menu, the output format is as follows.

*** & HDV: HDV 50i

*** & DVCAM: DVCAM 50i

When a clip with a different format than that above is played, with [Country] set to [PAL Area], the output format is as follows.

*** & HDV: N/A

*** & DVCAM: DVCAM 50i

SD: DVCAM 50i (UDF/SD mode)

When [Rec Format] is set to [HQ 1080/23.98P] or [HQ 720/23.98P] (video format recorded in pure 23.98P), the playback video is not output on i.LINK (DVCAM).

In UDF/SD mode, playback video is not output using i.LINK (DVCAM) when [Rec Format] is set to [IMX50].

Backup Battery Replacement

This recorder uses a backup battery to retain various setting data.

A lithium battery (CR2032) for backup is mounted in the recorder at the factory.

The backup battery retains the date, time, and timecode in Free Run mode even when no operating power is being supplied.

Service life of the backup battery

When the backup battery's voltage falls, the backup battery low-voltage warning appears on the LCD monitor.

If this warning appears, replace the battery as soon as possible.

WARNING

- Battery may explode if mistreated. Do not recharge, disassemble, or dispose of in fire.
- Batteries shall not be exposed to excessive heat such as sunshine, fire or the like.

CAUTION

Danger of explosion if battery is incorrectly replaced. Replace only with the same or equivalent type recommended by the manufacturer.

When you dispose of the battery, you must obey the law in the relative area or country.

Replacing the backup battery

Notes

- Be sure to turn the power to OFF when replacing the backup battery.
- Be careful not to drop the removed screw into the recorder.

- 1 Remove the screw of the backup battery holder, then remove the cover. Insert a nonmetallic item, such as a plastic toothpick, to the side of the battery and lever the battery out of its compartment.**

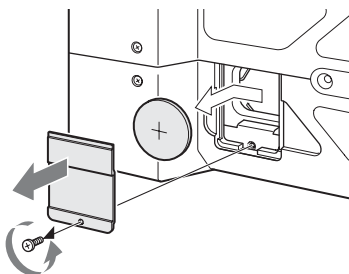

- 2 Insert a new backup battery (CR2032) with the + symbol on the battery facing outside.**

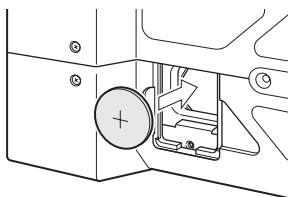

- 3 Attach the cover in the original position.**

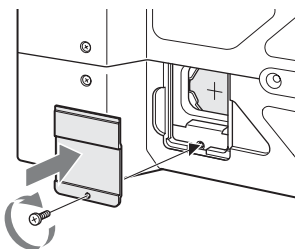

Troubleshooting

Power

Symptoms	Cause	Remedy
The recorder does not power on when you set the power button to ON.	No battery pack is mounted and no power is supplied to the DC IN connector.	Mount a battery pack (<i>page 11</i>) or connect to AC power using the BC-U1 or BC-U2 (<i>page 12</i>).
	The battery pack is completely exhausted.	Replace the battery pack with a fully charged one (<i>page 11</i>).
The power supply cuts while operating.	The battery pack becomes exhausted.	Replace the battery pack with a fully charged one (<i>page 11</i>).
The battery pack becomes exhausted very quickly.	The ambient temperature is very low.	This owes to the battery characteristics and is not a defect.
	The battery pack is inadequately charged.	Recharge the battery pack (<i>page 11</i>). If the battery pack is soon exhausted even after you charged it fully, it may come to the end of its life. Replace it with a new one.

Recording/playback

Symptoms	Cause	Remedy
Recording does not start when you press the REC + PLAY/PAUSE buttons.	The power is turned OFF.	Set the power button to ON.
	The SxS memory card is write-protected.	Release the write-protection, or replace the card with a non-protected SxS memory card.
	The SxS memory card is full.	Replace the card with one having sufficient space.
	The SxS memory card needs restoration.	Restore the memory card (<i>page 14</i>).
Playback does not start when you press the PLAY/PAUSE button.	The power is turned OFF.	Set the power button to ON.
The supplied IR Remote Commander does not work.	Remote control operation is disabled.	Enable remote control operation (<i>page 56</i>).
	The battery of the IR Remote Commander is exhausted.	Replace the battery with a new one (<i>page 8</i>).

External devices

Symptoms	Cause	Remedy
The equipment connected to the recorder via an i.LINK connection does not react as expected, for example, no picture appears on its screen.	It sometimes takes time for the connected equipment to recognize the operation.	Wait for about 15 seconds. If the connected equipment still does not react, do the following: <ul style="list-style-type: none">• Check the i.LINK cable, for example, by re-plugging it.• Turn the power off, and connect the cable again.• Change the i.LINK cable.

Error indications

The recorder informs you of situations where warning, caution, or an operation check is required, through messages on the LCD monitor, the tally lamps, and a buzzer.

The buzzer is output to the built-in speaker or to the headphones connected via the headphone connector. The buzzer volume can be set with [Alarm Level] in [Audio Output] (page 49) in the [AUDIO SET] menu. The recorder stops operation after the following indications.

Error indication on LCD	Buzzer	Tally lamps	Cause and measures
E + Error code	Continuous	Rapidly flashing	The recorder may be defective. Recording stops even if ●REC is displayed on the LCD monitor. Turn off the power and check the connected equipment, cables, and media. If they are not defective, turn on the power again. If the error persists, consult Sony service personnel. (If power cannot be turned off by setting the power button to OFF, remove both the battery pack and the DC IN source.)

Warning indications

When one of the following indications is generated, follow the message to clear the problem.

Warning indication on LCD	Buzzer	Tally lamps	Cause and measures
Media Near Full	Intermittent	Flashing	Free space on the SxS memory cards has become insufficient. Replace it with another at the earliest opportunity.
Media Full	Continuous	Rapidly flashing	No space is left on the SxS memory cards. Recording, clip copying and clip division cannot be performed. Replace it with another.
Battery Near End	Intermittent	Flashing	The battery power will be exhausted soon. Charge the battery pack at the earliest opportunity.
Battery End	Continuous	Rapidly flashing	The battery pack is exhausted. Recording cannot be performed. Stop operation and change the battery pack.
Temperature High	Intermittent	Flashing	The internal temperature has risen above a safe operation limit. Suspend operation, turn off the power, and wait until the temperature falls.
Voltage Low	Intermittent	Flashing	The DC IN voltage has become low (stage 1). Check the power supply.
Insufficient Voltage	Continuous	Rapidly flashing	The DC IN voltage is too low (stage 2). Recording cannot be performed. Connect other power source.
HDD A ¹) Battery Near End	Intermittent	Flashing	The battery power of the connected HDD will be exhausted soon. Change the battery at the earliest opportunity.
HDD A ¹) Battery End	Continuous	Rapidly flashing	The battery of the connected HDD is exhausted. Recording cannot be performed. Stop operation to change the battery.
Please disconnect i.LINK Need to Reboot			You cannot use both an i.LINK connection and an IFU-WLM3 connection at the same time. Turn off the power, and disconnect one of the connections.
Battery Error Please Change Battery			An error was detected with the battery pack. Replace the battery pack with a normal one.
Backup Battery End Please Change			The remaining power of the backup battery is insufficient. Replace the battery with a new one.

Warning indication on LCD	Buzzer	Tally lamps	Cause and measures
Unknown Media(A) ² Please Change			A partitioned memory card or one that contains recorded clips exceeding the number permitted with this recorder is loaded. This card cannot be used with this recorder. Remove it and load a compatible card.
Media Error Media(A) ² Needs to be Restored			An error occurred with the memory card. The card requires restoration. Remove the card, load it again, and restore it.
Media Error Cannot Record to Media(A) ²			Recording cannot be done, as the memory card is defective. As playback may be possible, it is recommended to replace it with another card after copying the clips, as required.
Media Error Cannot Use Media(A) ²			Neither recording nor playback can be done, as the memory card is defective. It cannot be operated with this recorder. Replace it with another card.
Will Switch Slots Soon			This is an advanced notice that the recorder will switch from the current memory card to the other memory card for continuous recording.
No Clip			There are no clips on the media. Check the selected card.
Cannot Use Media(A) ³ Unsupported File System			A media of a different file system or an unformatted media was inserted. It cannot be used with this recorder. Replace it with another card or format it with this recorder.
In This File System Cannot Use Media(A) ²			A memory card that is not compatible with the current file system is inserted. Replace the card from the respective slot, format it with the recorder, or switch the F.Sys. mode.
Same File Already Exists Change Media(A) ³			A clip with the same name exists on the media to which you want to copy. Replace the media with different media.
Video Format Mismatch			The external signal input via the i.LINK connection cannot be recorded, as the [Rec Format] setting is different from the signal format of the external input signal. Change [Rec Format] in [System] in the [OTHERS] menu to match it to that of the external signal.
Copy Protected Input Cannot Record			The external signal input via the i.LINK connection cannot be recorded, as the stream is copy-protected. Check the input signal.
Media Error Playback Halted			An error occurred in reading data from the memory card, and playback cannot be continued. If this frequently occurs, change the memory card after copying the clips, as required.
Media(A) ² Error			Recording cannot be done, as an error occurred with the memory card. If this frequently occurs, change the memory card.
Media Reached Rewriting Limit Change Media(A) ²			The memory card comes to the end of its service life. Make a backup copy and replace the card with another one as soon as possible. Recording/playback may not be performed properly if you continue to use the card.
Reached Clip Number Limit Copy Completed to xx/xx			The maximum number of clips for the media is reached, so copying cannot continue. (xx/xx indicates the completed copy operations.) Replace the media.

Warning indication on LCD	Buzzer	Tally lamps	Cause and measures
Not Enough Capacity Copy Completed to xx/xx			There is not enough capacity for copying on the media. (xx/xx indicates the completed copy operations.) Replace the media.
Reached Duplication Limit Copy Completed to xx/xx			There are already 10 or more clips with the same name as the clip that you want to copy, so copying cannot continue. (xx/xx indicates the completed copy operations.) Replace the card.
Copy Error! (CANCEL:Abort) No Media!			There is no memory card inserted in the slot. Insert a card.
Copy Error! (CANCEL:Abort) Media Write Protected			The memory card is write-protected. Remove the card from the slot and remove the write-protection.
Copy Error! (CANCEL:Abort) Cannot Use Media(A) ³⁾			<ul style="list-style-type: none"> • A memory card that cannot be used with the recorder is inserted. Replace the card in the respective slot. • An error occurred during error checking when copying. Try copying again.
Copy General Files NG: Cannot Copy			Copying of a general file failed. Retry copying.
File System Mismatch			A media with an different file system was inserted. Replace the media, format it with the recorder, or switch to F.Sys. mode.
Unsupported Device			An unsupported type of media is connected to the unit. Replace the media.
Reached Folder Number Limit Change Media (USB)			The maximum number of folders the media can support has been reached. Delete folders or replace media.
Copy All Clips Cancelled			Copying was aborted because a recording operation was started or because the operation was cancelled.

1) B for a HDD connected to slot B

2) (B) for the card in slot B

3) (B) for the card inserted in slot B, (USB) for the USB media connected to the external device connector

Licenses

MPEG-4 AVC Patent Portfolio License

THIS PRODUCT IS LICENSED UNDER THE AVC PATENT PORTFOLIO LICENSE FOR THE PERSONAL USE OF A CONSUMER OR OTHER USES IN WHICH IT DOES NOT RECEIVE REMUNERATION TO

- (i) ENCODE VIDEO IN COMPLIANCE WITH THE AVC STANDARD (“AVC VIDEO”) AND/OR
- (ii) DECODE AVC VIDEO THAT WAS ENCODED BY A CONSUMER ENGAGED IN A PERSONAL ACTIVITY AND/OR WAS OBTAINED FROM A VIDEO PROVIDER LICENSED TO PROVIDE AVC VIDEO.

NO LICENSE IS GRANTED OR SHALL BE IMPLIED FOR ANY OTHER USE. ADDITIONAL INFORMATION MAY BE OBTAINED FROM MPEG LA, L.L.C. SEE [HTTP://WWW.MPEGLA.COM](http://www.mpegla.com)

MPEG-2 Video Patent Portfolio License

ANY USE OF THIS PRODUCT OTHER THAN CONSUMER PERSONAL USE IN ANY MANNER THAT COMPLIES WITH THE MPEG-2 STANDARD FOR ENCODING VIDEO INFORMATION FOR PACKAGED MEDIA IS EXPRESSLY PROHIBITED WITHOUT A LICENSE UNDER APPLICABLE PATENTS IN THE MPEG-2 PATENT PORTFOLIO, WHICH LICENSE IS AVAILABLE FROM MPEG LA, L.L.C., 250 STEELE STREET, SUITE 300, DENVER, COLORADO 80206.

“PACKAGED MEDIA” means any storage media storing MPEG-2 video information such as DVD movie which are sold/distributed to general consumers. Disc replicators or sellers of the PACKAGED MEDIA need to obtain licenses for their own business from MPEG LA. Please

contact MPEG LA for any further information. MPEG LA, L.L.C., 250 STEELE STREET, SUITE 300, DENVER, COLORADO 80206 <http://www.mpegla.com>

Bitmap Fonts

This product uses RICOH Bitmap Fonts produced and sold by Ricoh Company, Ltd.

On accessing software to which the GPL applies

This product uses software to which the GPL version 2 applies. This informs you that you have a right to have access to, modify, and redistribute source code for these software programs under the conditions of the GPL version 2. The source code is provided on the internet. Use the following URL and follow the download instructions.

<http://www.sony.net/Products/Linux/common/search.html>

We would prefer that you do not contact us about the contents of the source code.

About OpenSSL

Because it uses the OpenSSL Toolkit, this product uses software developed by the OpenSSL Project (<http://www.openssl.org/>).

OpenSSL License

```

-----
/*
=====
* Copyright (c) 1998-2008 The OpenSSL
* Project. All rights reserved.
*
* Redistribution and use in source and
* binary forms, with or without
* modification, are permitted provided
* that the following conditions are met:
*
* 1. Redistributions of source code must
* retain the above copyright notice,
* this list of conditions and the
* following disclaimer.
*

```

* 2. Redistributions in binary form must
 * reproduce the above copyright
 * notice, this list of conditions and the
 * following disclaimer in the
 * documentation and/or other
 * materials provided with the
 * distribution.
 *

* 3. All advertising materials mentioning
 * features or use of this software must
 * display the following
 * acknowledgment:
 * "This product includes software
 * developed by the OpenSSL Project
 * for use in the OpenSSL Toolkit.
 * (<http://www.openssl.org/>)"
 *

* 4. The names "OpenSSL Toolkit" and
 * "OpenSSL Project" must not be used
 * to endorse or promote products
 * derived from this software without
 * prior written permission. For written
 * permission, please contact openssl-
 * core@openssl.org.
 *

* 5. Products derived from this software
 * may not be called "OpenSSL" nor
 * may "OpenSSL" appear in their
 * names without prior written
 * permission of the OpenSSL Project.
 *

* 6. Redistributions of any form
 * whatsoever must retain the following
 * acknowledgment:
 * "This product includes software
 * developed by the OpenSSL Project
 * for use in the OpenSSL Toolkit
 * (<http://www.openssl.org/>)"
 *

* THIS SOFTWARE IS PROVIDED BY
 * THE OpenSSL PROJECT ``AS IS"
 * AND ANY EXPRESSED OR IMPLIED
 * WARRANTIES, INCLUDING, BUT NOT
 * LIMITED TO, THE IMPLIED
 * WARRANTIES OF MERCHANTABILITY
 * AND FITNESS FOR A PARTICULAR
 * PURPOSE ARE DISCLAIMED. IN NO
 * EVENT SHALL THE OpenSSL
 * PROJECT OR ITS CONTRIBUTORS BE
 * LIABLE FOR ANY DIRECT, INDIRECT,
 * INCIDENTAL, SPECIAL, EXEMPLARY,
 * OR CONSEQUENTIAL DAMAGES

* (INCLUDING, BUT NOT LIMITED TO,
 * PROCUREMENT OF SUBSTITUTE
 * GOODS OR SERVICES;
 * LOSS OF USE, DATA, OR PROFITS;
 * OR BUSINESS INTERRUPTION)
 * HOWEVER CAUSED AND ON ANY
 * THEORY OF LIABILITY, WHETHER IN
 * CONTRACT, STRICT LIABILITY, OR
 * TORT (INCLUDING NEGLIGENCE OR
 * OTHERWISE)
 * ARISING IN ANY WAY OUT OF THE
 * USE OF THIS SOFTWARE, EVEN IF
 * ADVISED OF THE POSSIBILITY OF
 * SUCH DAMAGE.
 *

=====
 * This product includes cryptographic
 * software written by Eric Young
 * (eay@cryptsoft.com). This product
 * includes software written by Tim
 * Hudson (tjh@cryptsoft.com).
 *
 * /

Original SSLeay License

 * Copyright (C) 1995-1998 Eric Young
 * (eay@cryptsoft.com)
 * All rights reserved.
 *
 * This package is an SSL
 * implementation written by Eric Young
 * (eay@cryptsoft.com).
 * The implementation was written so as
 * to conform with Netscapes SSL.
 *
 * This library is free for commercial and
 * non-commercial use as long as the
 * following conditions are aheared to.
 * The following conditions apply to all
 * code found in this distribution. be it the
 * RC4, RSA, lhash, DES, etc., code; not
 * just the SSL code. The SSL
 * documentation included with this
 * distribution is covered by the same
 * copyright terms except that the holder
 * is Tim Hudson (tjh@cryptsoft.com).
 *
 * Copyright remains Eric Young's, and

```

* as such any Copyright notices in the
* code are not to be removed.
* If this package is used in a product,
* Eric Young should be given attribution
* as the author of the parts of the library
* used.
* This can be in the form of a textual
* message at program startup or in
* documentation (online or textual)
* provided with the package.
*
* Redistribution and use in source and
* binary forms, with or without
* modification, are permitted provided
* that the following conditions are met:
* 1. Redistributions of source code must
*    retain the copyright notice, this list of
*    conditions and the following
*    disclaimer.
* 2. Redistributions in binary form must
*    reproduce the above copyright
*    notice, this list of conditions and the
*    following disclaimer in the
*    documentation and/or other
*    materials provided with the
*    distribution.
* 3. All advertising materials mentioning
*    features or use of this software must
*    display the following
*    acknowledgement:
*    "This product includes
*    cryptographic software written by
*    Eric Young (eay@cryptsoft.com)"
*    The word 'cryptographic' can be left
*    out if the rouines from the library
*    being used are not cryptographic
*    related :-).
* 4. If you include any Windows specific
*    code (or a derivative thereof) from
*    the apps directory (application
*    code) you must include an
*    acknowledgement:
*    "This product includes software
*    written by Tim Hudson
*    (tjh@cryptsoft.com)"
*
* THIS SOFTWARE IS PROVIDED BY
* ERIC YOUNG ``AS IS" AND ANY
* EXPRESS OR IMPLIED WARRANTIES,
* INCLUDING, BUT NOT LIMITED TO,
* THE IMPLIED WARRANTIES OF
* MERCHANTABILITY AND FITNESS

```

```

* FOR A PARTICULAR PURPOSE ARE
* DISCLAIMED. IN NO EVENT SHALL
* THE AUTHOR OR CONTRIBUTORS BE
* LIABLE FOR ANY DIRECT, INDIRECT,
* INCIDENTAL, SPECIAL, EXEMPLARY,
* OR CONSEQUENTIAL DAMAGES
* (INCLUDING, BUT NOT LIMITED TO,
* PROCUREMENT OF SUBSTITUTE
* GOODS OR SERVICES; LOSS OF USE,
* DATA, OR PROFITS; OR BUSINESS
* INTERRUPTION)
* HOWEVER CAUSED AND ON ANY
* THEORY OF LIABILITY, WHETHER IN
* CONTRACT, STRICT LIABILITY, OR
* TORT (INCLUDING NEGLIGENCE OR
* OTHERWISE) ARISING IN ANY WAY
* OUT OF THE USE OF THIS SOFTWARE,
* EVEN IF ADVISED OF THE
* POSSIBILITY OF SUCH DAMAGE.
*
* The licence and distribution terms for
* any publically available version or
* derivative of this code cannot be
* changed. i.e. this code cannot simply
* be copied and put under another
* distribution licence [including the GNU
* Public Licence.]
* /

```

About JQuery,Sizzle.js

This product uses the following software, released under MIT License.

jQuery JavaScript Library v1.7.2
<http://jquery.com/>
Copyright 2011, John Resig

Sizzle.js
<http://sizzlejs.com/>
Copyright 2011, The Dojo Foundation
Date: Wed Mar 21 12:46:34 2012 -0700

MIT License

Permission is hereby granted, free of charge, to any person obtaining a copy of this software and associated documentation files (the "Software"), to deal in the Software without restriction, including without limitation the rights to use, copy, modify, merge, publish, distribute, sublicense, and/or sell copies of the Software, and to permit persons to whom the Software is furnished to do so, subject to the following conditions:

The above copyright notice and this permission notice shall be included in all copies or substantial portions of the Software.

THE SOFTWARE IS PROVIDED "AS IS", WITHOUT WARRANTY OF ANY KIND, EXPRESS OR IMPLIED, INCLUDING BUT NOT LIMITED TO THE WARRANTIES OF MERCHANTABILITY, FITNESS FOR A PARTICULAR PURPOSE AND NONINFRINGEMENT. IN NO EVENT SHALL THE AUTHORS OR COPYRIGHT HOLDERS BE LIABLE FOR ANY CLAIM, DAMAGES OR OTHER LIABILITY, WHETHER IN AN ACTION OF CONTRACT, TORT OR OTHERWISE, ARISING FROM, OUT OF OR IN CONNECTION WITH THE SOFTWARE OR THE USE OR OTHER DEALINGS IN THE SOFTWARE.

Specifications

General

Power supply
12 V DC

Power consumption
Approx. 13 W (while recording, LCD monitor On)
Approx. 22.5 W (while recording, LCD monitor On, CBK-WA100 connected)

Inrush current
(1) Maximum possible inrush current at initial switch-on (Voltage changes caused by manual switching):
50 A peak, 9.5 A r.m.s. (240 V AC)
(2) Inrush current after a mains interruption of five seconds (Voltage changes caused at zero-crossing):
3 A peak, 0.7 A r.m.s. (240 V AC)

Operating temperature
0 °C to 40 °C (32 °F to 104 °F)

Storage temperature
-20 °C to +60 °C (-4 °F to +140 °F)

Mass
Approx. 1 kg (2 lb. 3.3 oz.) (excluding the audio input box)
Approx. 1.2 kg (2 lb. 10 oz.) (including the audio input box)

Dimensions (width / height / depth)
Approx. 124 × 86 × 237 mm
(5 × 3 1/2 × 9 3/8 in.) (excluding audio input box, excluding protrusions)
Approx. 124 × 115 × 237 mm
(5 × 4 5/8 × 9 3/8 in.) (including audio input box, excluding protrusions)

Recording/playback formats (video)
UDF
HD422 mode: MPEG-2 422P@HL, 50 Mbps / CBR
HD420 HQ mode: MPEG-2 MP@HL, 35 Mbps / VBR
DVCAM mode: DVCAM
IMX 50 mode: MPEG-2 422P@ML Intra, 50 Mbps / CBR
exFAT
XAVC-I mode: XAVC-Intra 422, 223 Mbps max, MPEG-4 AVC / H.264 / CBG
XAVC-Long50 mode: XAVC-Long 422, 50 Mbps max, MPEG-4 AVC / H.264 / VBR

XAVC-Long35 mode: XAVC-Long 422, 35 Mbps max, MPEG-4 AVC / H.264 / VBR
XAVC-Long25 mode: XAVC-Long 422, 25 Mbps max, MPEG-4 AVC / H.264 / VBR
HD422 mode: MPEG-2 422P@HL, 50 Mbps / CBR

HD420 HQ mode: MPEG-2 MP@HL, 35 Mbps / VBR

DVCAM mode: DVCAM

IMX 50 mode: MPEG-2 422P@ML Intra, 50 Mbps / CBR

FAT

HQ mode: MPEG-2 MP@HL, 35 Mbps / VBR

SP mode: MPEG-2 MP@H14, 25Mbps / CBR

DVCAM mode: DVCAM

Recording/playback formats (audio)

UDF

HD422 mode: LPCM 24 bits, 48 kHz, 4 channels

IMX 50 mode: LPCM 24/16 bits, 48 kHz, 4 channels

DVCAM (i.LINK) mode: LPCM 16 bits, 48 kHz, 2 channels

Other modes: LPCM 16 bits, 48 kHz, 4 channels

exFAT

XAVC-I mode: LPCM 24 bits, 48 kHz, 4 channels

XAVC-L mode: LPCM 24 bits, 48 kHz, 4 channels

HD422 mode: LPCM 24 bits, 48 kHz, 4 channels

IMX 50 mode: LPCM 24/16 bits, 48 kHz, 4 channels

DVCAM (i.LINK) mode: LPCM 16 bits, 48 kHz, 2 channels

Other modes: LPCM 16 bits, 48 kHz, 4 channels

FAT

HD mode: LPCM 16 bits, 48 kHz, 4 channels

SD mode: LPCM 16 bits, 48 kHz, 2 channels

Recording/playback time

Example when using an SBP-128B (128 GB)

UDF

HD422 mode: Approx. 240 min.

HQ mode: Approx. 360 min.

IMX50 mode: Approx. 240 min.

DVCAM mode: Approx. 440 min.

exFAT

XAVC-I mode: Approx. 60 min.

XAVC-L mode

XAVC-L50: Approx. 240 min.

XAVC-L35: Approx. 340 min.

XAVC-L25: Approx. 440 min.

HD422 mode: Approx. 240 min.

HQ mode: Approx. 360 min.

IMX50 mode: Approx. 240 min.

DVCAM mode: Approx. 440 min.

FAT

HQ mode: Approx. 400 min.

SP mode: Approx. 560 min.

DVCAM mode: Approx. 520 min.

Note

The recording and playback time may vary due to operating conditions and memory characteristics.

Battery drive time

Approx. 110 min. when using BP-U30

Approx. 220 min. when using BP-U60

Approx. 330 min. when using BP-U90

(While recording: LCD monitor On)

Media drive

Media type

ExpressCard/34 slot (2)

Inputs/outputs

DC output

4-pin circular connector, CBK-WA100 only (1)

SDI input

BNC (1), 3G SDI/HD/SD selectable, SMPTE 292M/259M/424M/425M

Analog video output

BNC (1), NTSC/PAL/HD-Y

SDI output

BNC (2), 3G SDI/HD/SD selectable, SMPTE 292M/259M/424M/425M

HDMI output

Type A 19-pin (1)

Audio inputs

XLR 3-pin (2) (CH-1, CH-2), +4 dBu (LINE), 0 dBu = 0.775 VRMS (reference level)

Analog audio outputs

Phono jack (2) (CH-1, CH-2), -10 dBu (47 kilohms load, reference level)

Headphone output

Stereo mini jack (1)

Mono speaker output

250 mW or more

i.LINK

IEEE 1394, 4-pin (1), HDV (HDV1080i)/
DVCAM stream input/output, S400

USB

4-pin Mini-B type (1)
Host A type (1)

DC input (12 V)

DC jack (12 V) (1)

Miscellaneous functions

Display

3.5-inch color LCD monitor: 960 (H) × 3
(RGB) memory card × 540 (V) pixels, 16:9
ratio

Supplied Accessories

BC-U1 battery charger/AC adapter (1)

Infrared remote controller (1)

USB cable (1)

Shoulder strap (1)

Side spacer (1)

Lithium battery (CR2032 for backup) (1)

Pre-installed in the recorder.

Lithium battery (CR2025 for remote controller)
(1)

Pre-installed in the remote controller.

Operating Instructions (CD-ROM) (1)

Before Using this Unit (1)

Warranty (1)

Optional Accessories

Battery pack

BP-U30, BP-U60, BP-U90

Battery charger/AC adapter

BC-U1, BC-U2

SxS memory cards

SxS PRO+ series

SxS PRO series

SxS-I series

SxS memory card USB reader/writer

SBAC-US20

Media adapter

QDA-EX1 (for XQD memory cards)

MEAD-SD02 (for SDHC cards)

USB wireless LAN module

IFU-WLM3

Wireless adapter

CBK-WA100

Notes

- Always make a test recording, and verify that it was recorded successfully.
SONY WILL NOT BE LIABLE FOR DAMAGES OF ANY KIND INCLUDING, BUT NOT LIMITED TO, COMPENSATION OR REIMBURSEMENT ON ACCOUNT OF FAILURE OF THIS UNIT OR ITS RECORDING MEDIA, EXTERNAL STORAGE SYSTEMS OR ANY OTHER MEDIA OR STORAGE SYSTEMS TO RECORD CONTENT OF ANY TYPE.
- Always verify that the unit is operating properly before use. SONY WILL NOT BE LIABLE FOR DAMAGES OF ANY KIND INCLUDING, BUT NOT LIMITED TO, COMPENSATION OR REIMBURSEMENT ON ACCOUNT OF THE LOSS OF PRESENT OR PROSPECTIVE PROFITS DUE TO FAILURE OF THIS UNIT, EITHER DURING THE WARRANTY PERIOD OR AFTER EXPIRATION OF THE WARRANTY, OR FOR ANY OTHER REASON WHATSOEVER.
- SONY WILL NOT BE LIABLE FOR CLAIMS OF ANY KIND MADE BY USERS OF THIS UNIT OR MADE BY THIRD PARTIES.
- SONY WILL NOT BE LIABLE FOR THE LOSS, REPAIR, OR REPRODUCTION OF ANY DATA RECORDED ON THE INTERNAL STORAGE SYSTEM, RECORDING MEDIA, EXTERNAL STORAGE SYSTEMS OR ANY OTHER MEDIA OR STORAGE SYSTEMS.
- SONY WILL NOT BE LIABLE FOR THE TERMINATION OR DISCONTINUATION OF ANY SERVICES RELATED TO THIS UNIT THAT MAY RESULT DUE TO CIRCUMSTANCES OF ANY KIND.

Design and specifications are subject to change without notice.

- XDCAM, SxS, SxS PRO, SxS-1, XQD, i.LINK , and Remote Commander are registered trademarks of Sony Corporation.
- The terms HDMI and HDMI High-Definition Multimedia Interface, and the HDMI Logo are trademarks or registered trademarks of HDMI Licensing LLC in the United States and other countries.
- The ExpressCard word mark and logos are owned by the Personal Computer Memory Card International Association (PCMCIA) and any use of such marks by Sony Corporation is under license. Other trademarks and trade names are those of their respective owners.

The products or system names appearing in this document are trademarks or registered trademarks of their respective owners.

