

CION™



AJA[®]
VIDEO SYSTEMS





Science of the Beautiful™

CION; definition – a descendant or offspring, esp. of an illustrious family

Aesthetic; definition –
Science of the beautiful

CION™ represents a new direction for AJA but one that is firmly rooted in everything we've learned over the last 21 years. Our foundation has always been to introduce ground breaking products that combine high quality engineering and passion. CION fulfills these core values but adds a new creative vision for the demanding needs of production for both today and tomorrow.

CION is the culmination of years of development; from it's foundation as an extension of our revolutionary Ki Pro range,

we've used a considered process to create a true production camera with a feature set and form factor that offers the user a wide variety of options both in the field and the studio. The design of the camera allows complete flexibility for the user to adapt to any environment.

We believe CION is a union of great design and functionality, an engineered aesthetic that we are proud to describe as the Science of the Beautiful.

CION™ | Operational Features Overview



Sensor

CION features a 4K APS-C sized CMOS sensor with an electronic global shutter and 12 stops of dynamic range. Lenses designed for Super 35mm cover the sensor imaging area and the global shutter eliminates the undesirable qualities associated with rolling shutter-based sensors.



Recording Formats

CION can record at 4K (4096x2160), UltraHD (3840x2160), 2K (2048x1080) and HD (1920x1080). 2K and HD are hardware scaled from the full 4K sensor, resulting in beautiful over-sampled images, which also retain your lens' focal length at any desired resolution. Frame rates up to 50 and 60p are supported - even at full 4K resolution.



Pak Media

CION uses AJA's proven SSD-based Pak storage. The robust high speed compact storage mounts directly in-camera and allows recording of 4K/UHD and 2K/HD as ProRes 4444, ProRes 422 (HQ), ProRes 422, ProRes 422 (LT) and ProRes (Proxy). Choose from generous 256GB or 512GB capacities and by utilizing the AJA Pak Dock (sold separately) you can transfer your footage over high-speed Thunderbolt™ or USB3.



PL Lens Mount

PL mount lenses are the industry standard for cinema and professional production cameras, and are widely available the world-over. In addition, CION's lens mount has been designed to be removable so third parties may develop mounts for other lens types.



Optical Low Pass Filter and IR Cut Filter

An integrated OLPF (Optical Low-Pass Filter) reduces unwanted moiré effects while still retaining vital image detail. The Infra-red cut filter produces high quality colors within the image by blocking unwanted light wavelengths.



Back Focus Adjustment

The inclusion of a mechanical back focus adjustment allows the proper calibration of the distance between lens and sensor. By making finely tuned adjustments, the sharpest image quality is assured.



Chassis

CION's sleek chassis is formed of gravity molded magnesium which is lightweight but extremely strong. Integrated steel rosettes allow you to mount industry standard accessories including hand grips and handle extensions directly to the camera body.



Mounting

Aluminum cheese plates are fitted to both the top and the bottom of the chassis to provide easy mounting of accessories from both AJA and third parties, with standard thread sizes to offer the widest range of compatibility.

User Interface

All interface controls are found on the side of the camera facing the operator to provide easy single user functionality. The menu structure itself is elegant and free of cumbersome sub-menu navigation. Confidently dial settings with a robust selection knob that gives clear mechanical feedback as you adjust.

A set of dedicated menu buttons offer direct access to vital camera settings including device status (STATUS), configuration (CONFIG), media management (MEDIA), format and frames per second (FPS), exposure index (EI) and white balance (WB). Easy to access and with a clear and consistent layout, you'll find the key controls at your fingertips, including play, fast-forward, rewind and stop.

The integrated confidence monitor not only displays the menu information but also previews your real-time image, allowing independent operation.

CION also offers powerful network-based control. Via the LAN connection, a web-browser UI allows for remote configuration of the camera. Your CION is completely controllable whether it's on a crane, jib or car mount from virtually any web browser.

LED VU meters are placed for easy and accurate audio monitoring. Control knobs for each audio channel allow adjustment of the input level. A headphone monitoring output and a headphone volume control knob are also provided.



Ergonomics

CION was designed to be comfortable, convenient and totally flexible for any shooting environment. A contoured shoulder pad fits comfortably to your shoulder for hand held use. An included top handle made of high grade aluminum and wood features an integrated LANC start/stop button. The handle base itself uses a standard 15mm rod and through hole to allow the additional mounting of third party accessories.

Conveniently Connected

All of the audio and video connections used on CION are industry-standard and thoughtfully positioned. Audio and video connectors have been placed where they are unobtrusive to the operator.

3G-SDI and HDMI monitor outputs, as well as a power output, make monitor and viewfinder additions to CION easy to implement. Utilizing CION's high-quality scaling capabilities, these dedicated monitoring outputs are always active even when working with 4K or Ultra HD.

CION was designed as an open camera, with no proprietary connectors.





- 1** 4x 3G-SDI main outputs for 4K/UHD and 2K/HD
In addition to baseband 4K/UHD and 2K/HD output AJA Raw via 3G-SDI at up to 4K 120 fps
- 2** LTC connector
For timecode input
- 3** Reference connector
For connecting genlock/sync
- 4** USB connector
For connecting USB powered accessories such as assistant lights
- 5** 2x XLR balanced analog audio inputs
Featuring independent selections for line, mic and phantom power
- 6** 2x LANC ports
For start/stop triggering via AJA LANC Collars or third-party LANC controllers
- 7** 2x 3G-SDI monitor outputs for 2K/HD
Outputs can be configured to display superimposed information
- 8** 2x HDMI monitor outputs
Features an option for superimposed camera data information (in 2K/HD); rear HDMI monitor output may additionally be configured for 4K up to 24 fps and Ultra HD up to 30 fps
- 9** 2-pin input power connector
For connecting to third-party battery plates

Rear Side of CION

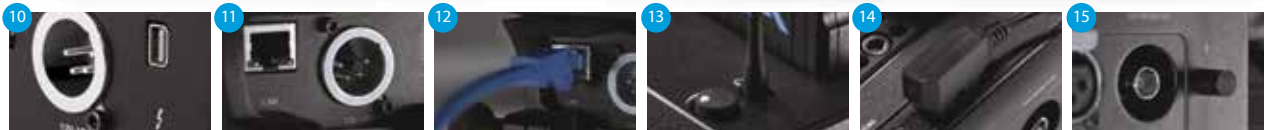

10 Thunderbolt™ connector
Output AJA Raw via Thunderbolt up to 4K 30 fps

11 4-pin XLR power connector

12 LAN connector
For network configuration and control

13 Mini TRS headphone jack and volume control knob

14 2-pin output power connector
For powering accessories like electronic viewfinders

15 Sensor plane post
Two positions are available for the sensor plane post

CION™ | Open Connectivity



Open up your world

CION is designed to create an open approach to accessorizing the camera.

This open system gives you immense flexibility no matter the shooting environment, both indoors and outdoors. From shoulder to tripod and from dolly to crane, CION keeps all of your options open.

Lenses

PL mount lenses are offered in standard focal lengths as well as zoom options. Manufacturers continue to release new and improved lenses designed for the demands of 4K resolution. Because the PL mount system is firmly established in production, you can choose the right lens to suit your creative needs.

Electronic Viewfinders

The open system approach allows you to choose from a wide range of electronic viewfinders and connect them directly via CION's HDMI or 3G-SDI. Dedicated monitoring outputs are even conveniently placed at the front of the camera. A convenient power connector near the front can also provide power for many electronic viewfinders.

Monitors

CION is a monitoring powerhouse. In addition to the front 3G-SDI and HDMI monitor outputs, additional rear 3G-SDI and HDMI outputs may also be used for monitoring. 4K and Ultra HD monitoring is possible via the 4x 3G-SDI main outputs and the rear HDMI output (when appropriately configured). You can configure CION so that everyone can see what's happening.

Microphones

Two balanced analog audio XLR inputs are built into CION allowing compatibility with a huge range of professional audio gear. You can choose to mount a shotgun microphone to the cold shoe found on the top handle or run longer cable from external mixers to CION. Independent switches for mic or line level as well as phantom power are provided meaning you're ready for any audio situation.

Rods and On-Camera Rigging

Removable cheese plates on the top and bottom of the camera make attaching accessories easy. The bottom cheese plate features 1/4-20 and 3/8-16 threaded holes. The AJA-provided top handle attaches to the top cheese plate via 1/4-20 screws for example. CION's top handle is based on standard 15mm rods, allowing compatibility with third-party accessories and endless possible configurations. Standard-sized rosettes on either side of the camera allow easy and dependable mounting points for handles and grips. By design, it's incredibly easy to add a wealth of accessories to CION to enhance your shooting experience.



CION™

Open Connectivity



Production Operation and Workflow

CION's considered design brings ease of operation to both field and studio based productions. For single users, set up and operation is intuitive and straightforward. For more complex productions camera operators, camera assistants and digital imaging technicians may all interact with CION without conflict. In such a scenario, the camera operator can use one monitor output for framing, the camera assistant another monitor output for judging focus and the digital imaging technician can use yet another monitor output as well as the web UI to configure the unit.

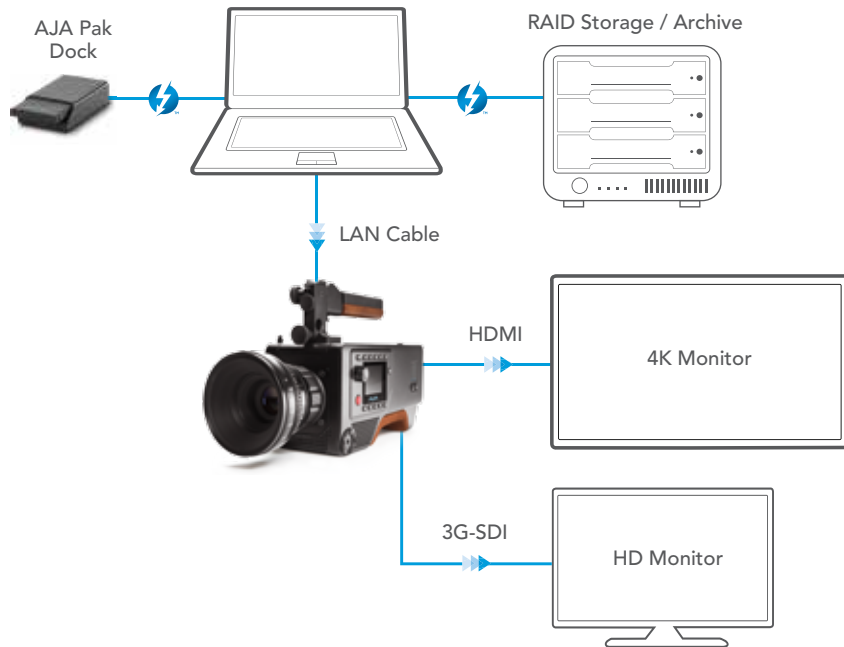

On-Set Backup and Monitoring Workflow

CION provides a multitude of on-set monitoring options for 4K/UHD and 2K/HD including a hardware dedicated down convert for 4K/UHD to 2K/HD. CION's outputs are simultaneously live allowing great flexibility in any scenario independent of resolution.

The AJA Pak Dock and Pak media are designed for field use, featuring a rugged and reliable form factor; unlike a bare SSD drive, AJA Pak media features a multi-insertion rated connector. Connecting to CION via the LAN connector provides real time information regarding the Pak currently in use and by utilizing a Thunderbolt enabled RAID storage drive you can quickly back up your Pak media as you shoot.

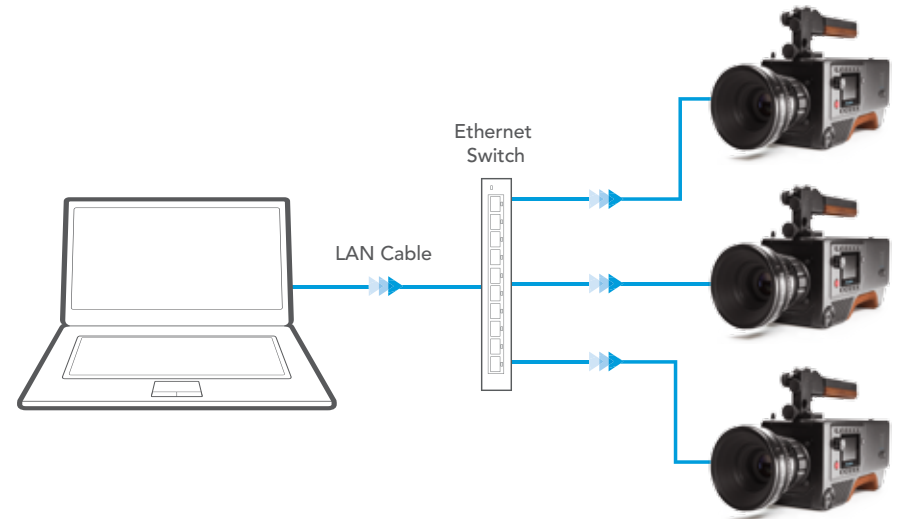

Multicam Gang Control

CION multicam shoots are straightforward to implement and manage by using a laptop with a simple ethernet switch and LAN cables. The web UI allows complete and independent set up of multiple CION cameras; you may name each camera and consolidate control of the cameras from within a web browser using the unique gang recording feature. The web UI will also allow realtime monitoring of the capacity of the Pak media used in each CION.

File naming options are easily accessed in CION's menu structure. There is even an option to create custom names for clips as well.

ProRes

Production and Post Unified

CION elegantly connects production and post with support for the Apple ProRes family of codecs. In 2007 AJA introduced the Io HD. It was the first device to offer hardware-based encoding of Apple ProRes. In 2009, AJA introduced the Ki Pro tapeless video recorder, the first camera-connected recorder to offer Apple ProRes encoding. CION draws on this distinguished history of support for Apple ProRes capturing vivid and detailed images that are easily manipulated in professional video editing and finishing applications.



Editing Software Compatibility

Native codec handling enhances your editorial experience, resulting in fast and responsive playback with no compromise in quality. Apple ProRes offers pristine image quality at extremely manageable file sizes. Using the latest generation of Apple Mac Pro and the AJA Io 4K along with Apple ProRes files from CION makes even 4K and Ultra HD editing a smooth experience.



High Frame Rate Workflow

CION is fully capable of outputting frame rates up to 120 fps as either 4K or UHD from its 4 x 3G-SDI outputs as AJA Raw. AJA's Corvid Ultra in conjunction with TruZoom software can take the AJA Raw output and replay it at up to 60 fps.



Ingest and Playout

Apple ProRes files also provide great compatibility with many of the leading playout tools from Gallery, Softron and Tools on Air to name but a few.

VFX and Finishing Applications

Whether you're manipulating complex visual effects sequences or creating beautiful looks in your preferred grading application, 10-bit Apple ProRes 422 and 12-bit Apple ProRes 4444 codecs maintain quality throughout the post production pipeline.





Front Baseplate

This accessory attaches to the bottom front cheese plate of CION. It features LWS spaced 15mm rod clamps. It is ideal for attaching follow focus units, lens supports and matteboxes.



Rear Baseplate

This piece is attached to the AJA-supplied Battery Adapter Plate and the heel of CION. The Rear Baseplate features LWS spaced 15mm rod clamps allowing you to attach accessories to the rear of CION.



Upper Rod Clamps

In some situations, you may want to attach accessories to LWS spaced 15mm rods above the lens instead of below it. The Upper Rod Clamps accessory makes this possible.



Viewfinder Mount

You may configure this accessory to support electronic viewfinders or even lightweight on-board monitors. Nearly infinite adjustments are possible via sliding 15mm rods and the L-shaped bracket.



Handle Grip

One Handle Grip is included with every CION; additional Handle Grips are available to purchase.



LANC Collar

A simple start/stop trigger that may be connected to either of CION's two LANC ports. The LANC Collar attaches to AJA handles or any 15mm rod. (One LANC Collar is included with CION.)



Rod to Rosette Adapter

This piece allows you to connect handles or other rosette attached accessories to 15mm rods.

User Interface

- 6x Dedicated Menu Buttons (STATUS, CONFIG, MEDIA, FPS, EI and WB)
- 4x Transport Buttons (Play, Fast Forward, Reverse Playback, Stop)
- 1x Media Unmount Button
- 1x Record Button
- 1x User Interface Control Knob
- 1x User Interface Screen, 320x240 LCD

Sensor Type

- CMOS, Electronic global shutter, 12 stops of dynamic range

Sensor Size

- 4K APS-C sized, 22.5mm x 11.9mm

Lens Mount

- PL (positive lock)

Filtration

- Optical Low Pass Filter (OLPF) and IR Cut Filter (combined)

Removable Storage

- AJA Pak media

Video Outputs

- 4x 3G-SDI Main Outputs (4x BNC connectors, 3G/1.485Gbps)
- 2x 3G-SDI Monitor Outputs (1x front mounted BNC connector, 1x rear mounted BNC connector, 3G/1.485Gbps)
- 2x HDMI Outputs (1x front mounted HDMI v1.3 Type A connector, 1x rear mounted HDMI v1.4 Type A connector)

Audio Inputs

- 2x Balanced Analog Audio Inputs (2x 3-pin XLR connectors with dedicated line/mic/48v selection switch per input)

Audio Output

- 1x Headphone Jack (3.5mm stereo mini TRS)

Reference Input

- 1x Reference Input (BNC connector, analog color black)

Timecode

- 1x LTC (BNC connector, 0.5 to 4.5Vpp)

Start/Stop Trigger

- 2x LANC (1x 2.5mm top connector and 1x 2.5mm side connector)

Network Interface

- 1x LAN connector (RJ45 connector, 10/100/1000)

Data Output

- AJA Raw via 3G-SDI up to 120 fps or Thunderbolt™ up to 30 fps

Weight

- 6.38 lbs / 2.89 kg (without top handle attached)
- 7.40 lbs / 3.35 kg (with top handle attached)

Power

- AC Range: 100-240 VAC 50/60Hz (AC adapter)
- DC Range: 12-18Vdc, 5A maximum (4-pin XLR connector or 2-pin input connector)
- Consumption: 38-42W typical, 45-47W maximum (Note: does not include power draw from 2-pin output connector)
- Output: 2-pin power output connector, 10W recommended maximum

Temperature Range

- Safe Operating Temperature Range: 5C to 40C
- Safe Storage Temperature Range (power OFF): -20C to 60C

Format/Frame Rate/Encoding/Output

• 4K

4K (4096x2160) progressive 23.98/24/25/29.97/30/50/59.94/60/119.88/120
 Apple ProRes 4444 or Apple ProRes 422 (all versions) up to/including 30 fps
 Apple ProRes 422 (or a lower data rate ProRes version) for 50/59.94/60 fps
 SDI output support for 23.98/24/25/29.97/30 fps (SDI 1-4 YCbCr, SDI 1-4 RGB or SDI 1 Raw)
 SDI output support for 50/59.94/60 fps (SDI 1-4 YCbCr or SDI 1-2 Raw)
 SDI output support for 119.88/120 fps (SDI 1-4 Raw)

• Ultra HD

Ultra HD (3840x2160) progressive 23.98/24/25/29.97/30/50/59.94/60/119.88/120
 Apple ProRes 4444 or Apple ProRes 422 (all versions) up to/including 30 fps
 Apple ProRes 422 (or a lower data rate ProRes version) for 50/59.94/60 fps
 SDI output support for 23.98/24/25/29.97/30 fps (SDI 1-4 YCbCr, SDI 1-4 RGB or SDI 1 Raw)
 SDI output support for 50/59.94/60 fps (SDI 1-4 YCbCr or SDI 1-2 RAW)
 SDI output support for 119.88/120 fps (SDI 1-4 Raw)

• 2K

2K (2048x1080) progressive 23.98/24/25/29.97/30/50/59.94/60
 Apple ProRes 4444 or Apple ProRes 422 (all versions) up to/including 30 fps
 Apple ProRes 422 (all versions) for 50/59.94/60 fps
 SDI output support for 23.98/24/25/29.97/30 fps (SDI 1 YCbCr, SDI 1-2 RGB, or SDI 1 RGB)
 SDI output support for 50/59.94/60 fps (SDI 1-2 YCbCr or SDI 1 YCbCr)

• 1080 progressive

1080 HD (1920x1080) progressive 23.98/24/25/29.97/30/50/59.94/60
 Apple ProRes 4444 or Apple ProRes 422 (all versions) up to/including 30 fps
 Apple ProRes 422 (all versions) for 50/59.94/60 fps
 SDI output support for 23.98/24/25/29.97/30 fps (SDI 1 YCbCr, SDI 1-2 RGB, or SDI 1 RGB)
 SDI output support for 50/59.94/60 fps (SDI 1-2 YCbCr or SDI 1 YCbCr)

• 1080 interlaced

1080 HD (1920x1080) interlaced 25/29.97/30
 Apple ProRes 422 (all versions) up to/including 30 fps.
 SDI output support up to/including 30 fps (SDI 1 YCbCr)

2-year warranty

AJA Video warrants that CION will be free from defects in materials and workmanship for a period of two years from the date of purchase.

About AJA Video Systems, Inc.

Since 1993, AJA Video has been a leading manufacturer of video interface and conversion solutions, bringing high-quality, cost-effective digital video products to the professional, broadcast and post-production markets.

AJA products are designed and manufactured at our facilities in Grass Valley, California, and sold through an extensive sales channel of resellers and systems integrators around the world. For further information, please see our website at www.aja.com

Because it matters.®

AJA Video Systems, Inc.
Grass Valley, California
www.aja.com • sales@aja.com • support@aja.com

