

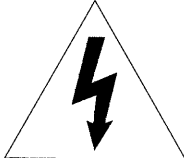

PROFESSIONAL

Model PMD501/PMD502 User Guide

Stereo Cassette Deck

marantz®

	CAUTION RISK OF ELECTRIC SHOCK DO NOT OPEN	
CAUTION: TO REDUCE THE RISK OF ELECTRIC SHOCK, DO NOT REMOVE COVER (OR BACK) NO USER-SERVICEABLE PARTS INSIDE REFER SERVICING TO QUALIFIED SERVICE PERSONNEL		

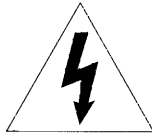

The lightning flash with arrowhead symbol, within an equilateral triangle, is intended to alert the user to the presence of uninsulated "dangerous voltage" within the product's enclosure that may be of sufficient magnitude to constitute a risk of electric shock to persons.



The exclamation point within an equilateral triangle is intended to alert the user to the presence of important operating and maintenance (servicing) instructions in the literature accompanying the appliance.

WARNING

**TO REDUCE THE RISK OF FIRE OR ELECTRIC SHOCK,
DO NOT EXPOSE THIS APPLIANCE TO RAIN OR MOISTURE.**

**CAUTION: TO PREVENT ELECTRIC SHOCK, MATCH WIDE
BLADE OF PLUG TO WIDE SLOT, FULLY INSERT.**

**ATTENTION: POUR ÉVITER LES CHOCS ÉLECTRIQUES,
INTRODUIRE LA LAME LA PLUS LARGE DE LA
FICHE DANS LA BORNE CORRESPONDANTE DE LA
PRISE ET POUSSER JUSQU'AU FOND.**

SAFETY INSTRUCTIONS

READ BEFORE OPERATING EQUIPMENT

This product was designed and manufactured to meet strict quality and safety standards. There are, however, some installation and operation precautions which you should be particularly aware of.

1. Read Instructions — All the safety and operating instructions should be read before the appliance is operated.
2. Retain Instructions — The safety and operating instructions should be retained for future reference.
3. Heed Warnings — All warnings on the appliance and in the operating instructions should be adhered to.
4. Follow Instructions — All operating and use instructions should be followed.
5. Water and Moisture — The appliance should not be used near water—for example, near a bathtub, wash-bowl, kitchen sink, laundry tub, in a wet basement, or near a swimming pool, etc.
6. Carts and Stands — The appliance should be used only with a cart or stand that is recommended by the manufacturer.
7. An appliance and cart combination should be moved with care. Quick stops, excessive force, and uneven surfaces may cause the appliance and cart combination to overturn.



8. Wall or Ceiling Mounting — The appliance should be mounted to a wall or ceiling only as recommended by the manufacturer.
9. Ventilation — The appliance should be situated so that its location or position does not interfere with its proper ventilation. For example, the appliance should not be situated on a bed, sofa, rug, or similar surface that may block the ventilation openings; or, placed in a built-in installation, such as a bookcase or cabinet that may impede the flow of air through the ventilation openings.
10. Heat — The appliance should be situated away from heat sources such as radiators, heat registers, stoves, or other appliances (including amplifiers) that produce heat.
11. Power Sources — The appliance should be connected to a power supply only of the type described in the operating instructions or as marked on the appliance.

12. Grounding or Polarization — Precautions should be taken so that the grounding or polarization means of an appliance is not defeated.

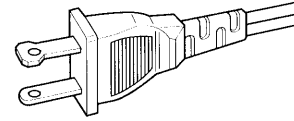

AC POLARIZED PLUG

13. Power-Cord Protection — Power-supply cords should be routed so that they are not likely to be walked on or pinched by items placed upon or against them, paying particular attention to cords at plugs, convenience receptacles, and the point where they exit from the appliance.
14. Cleaning — The appliance should be cleaned only as recommended by the manufacturer.
15. Power Lines — An outdoor antenna should be located away from power lines.
16. Outdoor Antenna Grounding — If an outside antenna is connected to the receiver, be sure the antenna system is grounded so as to provide some protection against voltage surges and built up static charges. Section 810 of the National Electrical Code, ANSI/NFPA No. 70 — 1984, provides information with respect to proper grounding of the mast and supporting structure, grounding of the lead-in wire to an antenna discharge unit, size of grounding conductors, location of antenna-discharge unit, connection to grounding electrodes, and requirements for the grounding electrode. See Fig. 1.
17. Nonuse Periods — The power cord of the appliance should be unplugged from the outlet when left unused for a long period of time.
18. Object and Liquid Entry — Care should be taken so that objects do not fall and liquids are not spilled into the enclosure through openings.
19. Damage Requiring Service — The appliance should be serviced by qualified service personnel when:
 - A. The power-supply cord or the plug has been damaged; or
 - B. Objects have fallen, or liquid has spilled into the appliance; or
 - C. The appliance has been exposed to rain; or
 - D. The appliance does not appear to operate normally or exhibits a marked change in performance; or
 - E. The appliance has been dropped, or the enclosure damaged.
20. Servicing — The user should not attempt to service the appliance beyond that described in the operating instructions. All other servicing should be referred to qualified service personnel.

FIGURE 1

**EXAMPLE OF ANTENNA GROUNDING ACCORDING TO
NATIONAL ELECTRICAL CODE INSTRUCTIONS
CONTAINED IN ARTICLE 810 - "RADIO AND TELEVISION EQUIPMENT"**

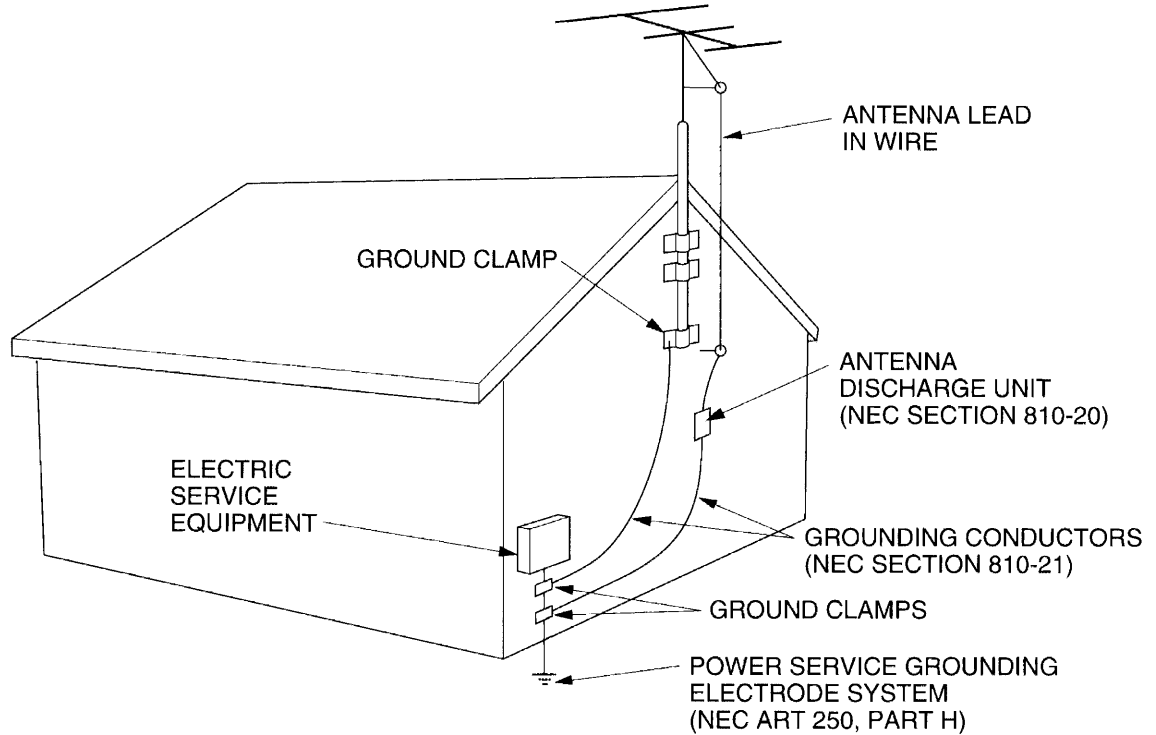

NEC - NATIONAL ELECTRICAL CODE

NOTE TO CATV SYSTEM INSTALLER:

This reminder is provided to call the CATV (Cable-TV) system installer's attention to Article 820-40 of the NEC that provides guidelines for proper grounding and, in particular, specified that the cable ground shall be connected to the grounding system of the building, as close to the point of cable entry as practical.

Model PMD501/502

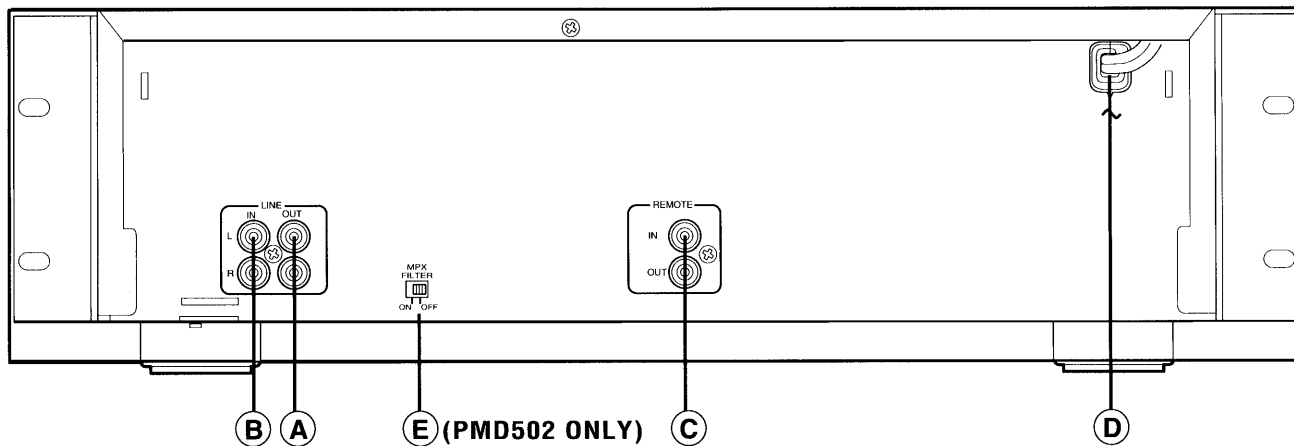

Model PMD501

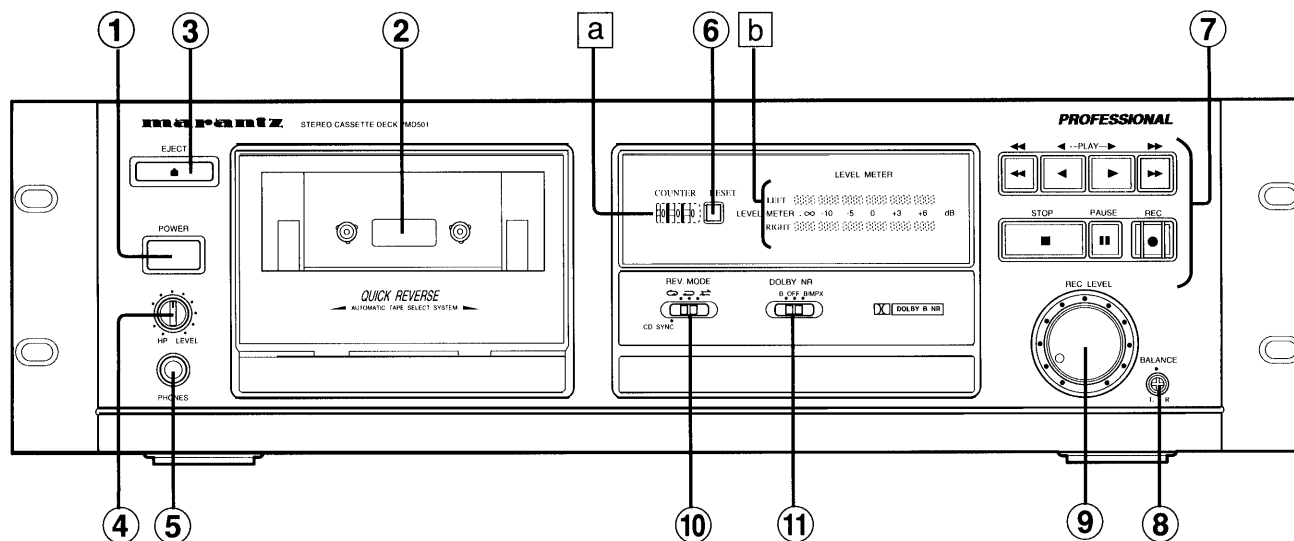

Model PMD502

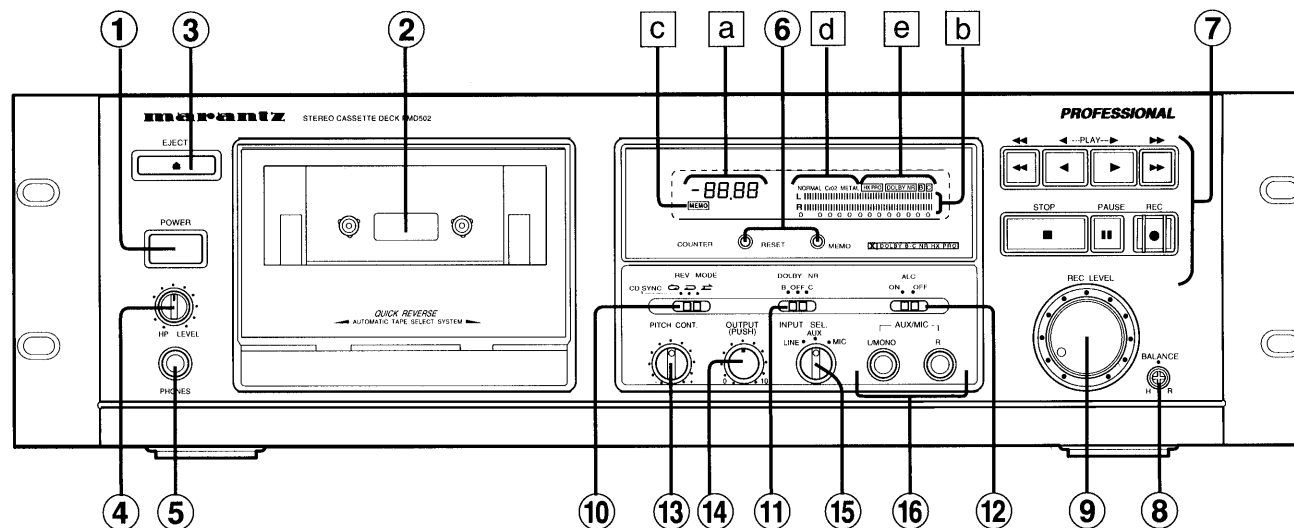

INTRODUCTION

Thank you for selecting the Marantz Model PMD501/PMD502 Stereo Cassette Deck for your audio system.

Please read these operating instructions carefully. We recommend that you read the entire user guide before you connect or operate the unit.

After you have reviewed the contents of this manual, we suggest that you make all system connections before you attempt to operate the unit.

Refer to the Figures on pages 4 and 10 of this user guide.

The callout numbers on the Figures correspond to those found in the text. All references to connections and controls are printed in **BOLD** type as they appear on the unit.

PRECAUTIONS

The following precautions should be taken when operating the equipment.

GENERAL PRECAUTIONS

When setting the equipment ensure that:

- the ventilation holes are not covered
 - air is allowed to circulate freely around the equipment
 - the equipment is on a vibration free surface
 - the equipment will not be exposed to interference from an external source
 - the equipment will not be exposed to excessive heat, cold, moisture or dust
 - the equipment will not be exposed to direct sunlight
 - the equipment will not be exposed to electrostatic discharges
- In addition, never place heavy objects on the equipment.
 - If a foreign body or water does enter the equipment, contact your nearest dealer or service center.
 - Do not pull out the plug by pulling on the mains lead, Hold the plug.

Dolby noise reduction and HX Pro headroom extension manufactured under license from Dolby Laboratories Licensing Corporation. HX Pro originated by Bang & Olufsen.

“DOLBY” the double-D symbol  and “HX PRO” are trademarks of Dolby Laboratories Licensing Corporation.

FEATURES

ALL-OPTICAL AUTOREVERSE

All autoreverse circuits are optically sensed, employing “quick autoreverse” circuits, to minimize lost signal while reversing tape. This applies in all playback and record modes, including autoreverse, continuous modes.

PITCH CONTROL (PMD502 ONLY)

Well features $\pm 15\%$ pitch control on playback.

TIME BASE TAPE COUNTERS (PMD502 ONLY)

The display on tape counter is only an approximate indication of minutes and seconds. It is most accurate when using 60 minute tapes.

DOLBY NR SYSTEMS

The Dolby NR (Noise Reduction) systems compress and amplify signals during recording in order to raise the signal-to-noise ratio on the tape. During playback, these signals are expanded and attenuated by the same amount, in order to regain the original dynamic range of the music. An additional result of this expansion and attenuation is that the noise floor of the recording is reduced significantly. Dolby B typically reduces noise by 10 dB, while Dolby C typically reduces noise by 20dB.

DOLBY HX PRO HEADROOM EXTENSION (PMD502 ONLY)

The Dolby HX PRO system monitors the total amount of effective bias during recording and instantaneously compensates for any excess bias by reducing the deck’s bias signal level accordingly. The system operates independently on each channel. HX PRO is unlike a noise reduction system because it functions only during recording and no decoding is required. Therefore, a tape recorded with the HX PRO system can be played back on any other cassette deck while retaining the benefits of HX PRO.

REAR PANEL CONNECTIONS

(A) LINE OUTPUT

These jacks should be connected to the TAPE INPUT of your PA or monitoring system.

(B) LINE INPUT

These jacks should be connected to the TAPE OUTPUT of your source.

(C) RC-5 REMOTE CONTROL JACKS

These jacks are for use with the Marantz RC5PMD serial remote control accessory. Connect the output of the remote control sensor to the RC-5 input of the PMD501/ PMD502. The RC-5 output of the PMD501/ PMD502 may be connected to the RC-5 input of other machines for multiple-machine control from the same RC5PMD remote control accessory.

(D) AC POWER CONNECTION





With the POWER switch set to OFF, plug the AC line cord into an AC outlet providing the proper voltage.

(E) MPX FILTER SWITCH (PMD502 ONLY)

When recording FM broadcasts with Dolby NR, set this switch to ON.

FRONT PANEL FEATURES

- ① **POWER switch**
For switching the unit on and off.
- ② **CASSETTE holder**
Insert cassette into this holder with the exposed tape facing downward.
- ③ **EJECT button**
For opening the cassette door.
- ④ **PHONES LEVEL control**
This control adjusts the volume of the headphone output.
- ⑤ **PHONES jack**
Use this jack to connect a pair of headphones with a stereo 1/4" connector.
- ⑥ **COUNTER buttons**
MEMO button (PMD502 ONLY)
When this button is pressed, MEMO indicator  will light up, and the position of the tape counter will be stored in memory. When the tape passes that location during fast winding, the transport will STOP. When the **MEMO** button is pressed again, the indicator will go out, and the memory will be cleared.
RESET button
Pressing this button will reset the counter to 000 (PMD501), 00.00 (0 minutes / 0 seconds. PMD502)
- ⑦ **CONTROL BUTTONS**
 - ▶ **PLAY(forward)**
Press this button to start playback in the forward direction.
 - ◀ **PLAY(reverse)**
Press this button to start playback in the reverse direction.
 - ◀◀ ▶▶ **FAST WIND**
Press these buttons to fast wind in the direction of the arrows. If the well is already in play mode, this button will place the well in skip to beginning of the next/previous program. (PMD502 ONLY)
 - **STOP**
Press this button to cancel any operation modes and to stop tape travel.
 - || **PAUSE**
If this button is pressed during recording or playback, the tape travel stops, the unit enters the REC-PAUSE mode. To cancel the pause mode and resume recording or playback, press the || **PAUSE** button again or press the **PLAY** button.
 - **REC**
Press this button to enter REC-PAUSE mode. Press the **PLAY** or **PAUSE** to initiate recording.
Note: Prior to recording, check the head direction (◀ or ▶) indicated by the lit play button indicator.
- ⑧ **REC BALANCE control**
Used to adjust the left-right balance of channels while recording.
- ⑨ **REC LEVEL control**
For adjusting the record input level.

- ⑩ **REVERSE MODE switch**
With this switch, you can select the autoreverse mode for recording, playback and CD synchronized mode for recording
 - ↔ : Select this mode to play or record in one direction (no autoreverse).
 - ↔ : Select this mode to play or record in both directions. When the end of side B is reached, the Deck will enter stop mode.
 - ↔ : Select this mode to continuously play both sides of a tape. When the end of side B is reached, the tape will autoreverse, and begin playing side A again, and so on, until the **STOP** button is pressed. In the record mode, this feature functions like the single pass Autoreverse  function.
- CD SYNC:** In REC mode, this mode works CD synchro recording when connected to a Marantz Professional CD player. (See descriptions of CD SYNCHRO RECORDING on page 7.)
- ⑪ **DOLBY NR SELECTOR**
This switch is used to select Dolby noise reduction for recording or playback. Most commercially available cassettes which display the Double-D Logo are encoded with Dolby B noise reduction. If recording FM broadcasts with Dolby NR, switch the MPX filter to ON.
- ⑫ **ALC SWITCH (PMD502 ONLY)**
 - OFF** : At this setting, the recording level can be adjusted manually by the **REC LEVEL** volume.
 - ON** : At this setting, the recording level is automatically set to optimum level irrespective of the **REC LEVEL** volume setting.
- ⑬ **PITCH CONTROL (PMD502 ONLY)**
This control allows ±15% variation in playback speed. A center detente allows you to locate the standard speed by feeling for the center "click". This control is not active while the unit is in the record mode.
- ⑭ **OUTPUT LEVEL VOLUME (PMD502 ONLY)**
With this control in the "out" position you can adjust the output level of the **LINE OUT**  on the rear panel. With this control in the "in" position, this prevents accidental changing of the Output level.
- ⑮ **INPUT SELECTOR (PMD502 ONLY)**
This switch selects the input signal source.
 - LINE** : In this position, the input signal will come from the rear panel **LINE IN**  jack.
 - AUX** : This position is used to input a line level signal from the front utilizing the 1/4" jacks .
 - MIC** : This position is used for microphone input from the front utilizing 1/4" jack . If you wish to record monaurally, input the microphone into the L / MONO jack only.
- ⑯ **AUX/MIC INPUT(PMD502 ONLY)**
Will accept AUX or microphone level input utilizing 1/4" plug.

DISPLAY

- a) TAPE COUNTER**
Displays the current tape position.
- b) BARGRAPH LEVEL METER**
This meter display the signal levels in stereo.
- c) MEMO INDICATOR (PMD502 ONLY)**
This indicator lights when the **MEMO** button ⑥ is pressed.
- d) TAPE TYPE INDICATORS (PMD502 ONLY)**
One of the indicators lights up to indicate the type of tape in the cassette compartment. The **METAL** indicator lights up when there is no cassette in the cassette compartment.
- e) DOLBY NR INDICATORS (PMD502 ONLY)**
The **DOLBY NR** indicator lights up according to the setting of the **DOLBY NR** selector ⑪.

OPERATION

PLAYBACK

1. Set the **POWER** ① button to ON.
2. Press the **EJECT** button ③ to open the cassette door ②.
3. Insert the Cassette into the Cassette Holder 2 with the exposed tape facing down, and side "A" facing you.
4. Reset the tape counter by pressing the **RESET** button ⑥.
5. If the tape has been encoded with Dolby NR, set the **Dolby NR** selector ⑪ accordingly.
6. Press either the **PLAY** ▶ or ◀ **PLAY** button ⑦ to play side "A" or side "B" of the cassette.
7. Press the **STOP** ■ button ⑦ to stop playback or the **PAUSE** button ⑦ to pause playback. Press the **PAUSE** or **PLAY** button ⑦ to continue playback.

NEXT/PREVIOUS (PMD502 ONLY)

1. When the deck is in the play mode, press the fast wind (▶▶ or ◀◀) button ⑦ in the direction in which you wish to skip. Press the **FAST WIND** button several times to skip several selections.
2. When the beginning of the correct selection is reached, the unit will automatically enter play mode.

Note: Deck will not auto-reverse while searching.

QUICK REVERSE

During recording or playback, the Quick Reverse function reverses the tape travel direction quickly by means of an infrared tape sensor.

- The cassette tapes used with this unit should have a transparent or near-transparent leader tape. When using leaderless tape, or a cassette with an opaque leader, quick reverse will not operate, and autoreverse will occur on a tension basis. When using a cassette with leader tape that is printed line or character, autoreverse will sometimes occur at that place.
- When a previously recorded tape is used for two way recording, the beginning of the reverse direction will not be erased for about 0.3 seconds. Therefore, when using a previously recorded tape, the beginning of the other tape side should be erased manually prior to recording.

- Quick Reverse will not occur if the transport has been moving for less than 15 seconds. In other words, if playback/recording is started less than 15 seconds before the end of a side, autoreverse will operate on a tension basis.
- The input signal is interrupted for about 1 second at the time of Quick Reverse. The sound cannot be recorded during this time.

RECORDING

1. Press the **EJECT** button ③ to open the cassette door.
2. Insert the cassette into the Cassette Holder ② with the exposed tape facing down.
3. Reset the tape counter by pressing the **RESET** button ⑥.
4. Set the **Dolby NR** selector ⑪ accordingly.
5. Press the **REC** ● button ⑦ to enter REC-PAUSE mode.
6. Adjust the record level using the **REC LEVEL** ⑨ control, so that the red section lights only at peaks in the music.
7. Press the **PLAY** ▶ or ◀ **PLAY** button ⑦ to initiate RECORD.
8. Press the **STOP** ■ button ⑦ to end recording, or press the **PAUSE** button to re-enter the REC-PAUSE mode. Press the **PAUSE** button again to continue recording.

QUICK REWIND

If the tape is rewound immediately after recording, without pressing **STOP** first, it will automatically enter stop mode at the point in the tape where recording was started. This is very useful for listening to a recording you have just completed, or for starting recording over again.

TAPE TYPES AND LENGTH

Any type of tape (Normal, Chrome, or Metal) can be used with the PMD501/PMD502. Chrome or Metal tapes have superior performance compared to Normal Tapes. The PMD501/ PMD502 can sense which kind of tape is being used, and will automatically adjust bias, EQ, etc.

Note: C-60 or C-90 length tapes are recommended, as C-120 tapes are often too thin, and can become entangled in the transport mechanism.

Note: The time counter of PMD502 is only approximate measurement of minutes and seconds. It is most accurate with 60 minute tapes.

CD SYNCHRO RECORDING

(When connected to a Marantz Professional CD player.)

The CD Synchro Recording is possible only when this unit is connected with a Marantz Professional CD player equipped with the Sync Recording function.

The CD Synchro Recording connection consists of a single RCA cable which runs to the RC-5 REMOTE C input jack on the rear panel of the PMD501/502, from the RC-5 REMOTE output jack on the rear panel of the Marantz CD player. (See Figure 6)

1. Insert cassette (rewound), set Dolby NR, and set reverse mode switch to either ⇄ or ⇂ mode (not ⇃ mode).
2. Press the **REC** ⑦ button. Check to see that REC-PAUSE mode is indicated.
3. Adjust the recording level with CD playing.
4. Set reverse mode switch to ⇃ mode.
5. Press the play button of the CD player.
6. The tape recording will start when the CD starts and stop when the CD player stops.

REMARKS

CAUTION

- If you must stop playback or recording in the middle of a tape, be sure to press the **STOP** ■ button first, then turn the power off.
If the power is turned off in the middle of an operation, the cassette tape remains loaded, and it may be impossible to eject. In such a case, turn the power on, enter PLAY mode, then press STOP, and the eject the tape.
- The same caution as above applies in case of power failure.
To prevent damage, never attempt to force the removal of a cassette while the power is off.

ERASURE OF TAPE

When a program source is recorded onto a tape, the previously recorded sound is erased automatically, and replaced with the new recording. If you wish to erase a tape without recording, set the REC LEVEL control to the minimum(0) position and let the tape travel in the Record mode.

AUTO TAPE SELECTOR

This unit is equipped with an auto tape selector which automatically sets the bias and equalizer level using the detection holes provided in the cassette shell. The bias and equalizer levels are automatically set according to the type of cassette as follows. (See Figure 3)

- | | | |
|--------------------------|------------------|-------------|
| • Normal tapes | EQ; 120 μ S, | Bias; Low |
| • CrO ₂ tapes | EQ; 70 μ S, | Bias; High |
| • Metal tapes | EQ; 70 μ S, | Bias; Metal |

TO PROTECT VALUABLE RECORDINGS

In the record mode, information previously recorded on the tape will automatically be erased. To prevent this from happening, use a small screwdriver to break out one or both safety tabs (See Figure 4).

It is possible to restore the recording capability of either side of the cassette by covering the opening with clear adhesive tape (See Figure 5).

CARE AND MAINTENANCE

This section describes the care and maintenance tasks that must be performed to optimize the operation of your Marantz equipment.

MAINTENANCE FOR TAPE

Head Cleaning

If the heads are not cleaned for a long period, dirt or dust may be deposited on the heads and capstans, causing degraded high-frequency characteristics, volume drop, or degraded recording and erasure performances.

To prevent this, clean the heads, etc., periodically as follows.

1. Turn the power off.
2. Open the cassette holder by pressing the **EJECT** button.
3. As shown in Figure 2, clean the parts which come in contact with tape, including the heads, capstans, tape guides, pinch wheels, etc., with a cotton swab soaked in head cleaning solution.

Head Demagnetization

When a magnetized metallic objects (such as a screwdriver tip, etc.) comes in contact with a head or capstan, or when the deck has been used for a long period of time, the head may be magnetized and noise may be generated. If the head is extremely magnetized, the high frequencies in recorded tapes could even be erased.

To prevent this, demagnetize the heads and capstans periodically (every 20 hours of use) using a commercially-available head demagnetizer. (For the operation, please refer to the instruction manual supplied with your head demagnetizer.)

Caution: Be sure to turn the power of the cassette deck off before using a head demagnetizer.

CLEANING OF EQUIPMENTAL SURFACES

The exterior finish of your unit will last indefinitely with proper care and cleaning. Never use scouring pads, steel wool, scouring powders or harsh chemical agents (e.g., lye solution), alcohol, thinners, benzine, insecticide or other volatile substances, as these will mar the finish of the equipment. Likewise, never use cloths containing chemical substances. If the equipment gets dirty, wipe the external surfaces with a soft, lint-free cloth.

If the equipment becomes heavily soiled:

- dilute some liquid soap in water, in a ratio of one part detergent to six parts water
- dip a soft, lint free cloth in the solution and wring the cloth out until it is damp
- wipe the equipment with the damp cloth
- dry the equipment by wiping it with a dry cloth.

REPAIRS

Only the most competent and qualified technicians should be allowed to service your unit. Marantz and its factory trained warranty station personnel have the knowledge and special equipment needed for repair and calibration of this precision instrument.

In the event of difficulty, call the toll-free telephone number listed on the face of the warranty to obtain the name address of the Marantz Authorized Service Center nearest you. In many cases, the dealer where you purchased your Marantz unit may be equipped to provide service. Please include the model and serial number of your unit together with a copy of your purchase receipt and a full description of what you feel is abnormal in its behavior.

TROUBLESHOOTING

Should faults occur it is in many cases not necessary to consult your dealer or technical service department. On the basis of the following checks you will be able to rectify a number of conditions yourself without difficulty.

If the condition cannot be remedied after the following check, please consult your dealer or nearest Marantz service agent.

- **The tape does not travel.**

1. Check that the power cord is plugged properly.
2. Check that the **POWER** switch is set to ON.
3. Check that the tape is rewound.

- **The tape travels, but no sound is output.**

1. Check that the cassette tape is recorded.
2. Check that the mixer, amplifiers and speakers are connected and functioning properly.

- **Tape will not record.**

1. Check that the protection tabs of cassette tape are not broken.
2. Check that the recording level is set properly.

- **Sound is distorted.**

1. Check that the recording level is not too high.
2. Check that the head is not dirty.

- **Sound is unstable.**

1. Check that the head is not dirty.
2. Check that the pinch wheels and capstans are not dirty.
3. Check that the tape is wound regularly.

- **Noise is noticeable.**

1. Check that the head is not dirty.
2. Check that the head is not magnetized.
3. Check that the **DOLBY NR** switch is set properly according to the tape.

- **Hum interferes with the sound.**

1. Check that cords are connected properly.
2. Check that there is not any source of magnetism (TV, motor, transformer, etc.) placed near the unit.
3. When this unit and amplifier are stacked, hum noise is sometimes generated depending on the amplifier model. In such a case, place the components in positions where interference does not occur.

NOTICE

- Quick reverse operation will only occur after the transport has been moving for 15 seconds. Before that time it take approximately 4 seconds to reverse.
- One second of audio is lost during quick reverse.
- Automatic search operations can only operate on one well at a time.
- Eject buttons will not function unless the deck is in the stop mode. Thus, if the power is turned off without hitting the stop button, the door may not open.
- The tape counters are only approximate measurements of minutes and seconds and are not intended for timing-critical applications. They are most accurate with 60 minute tapes.

TECHNICAL SPECIFICATIONS *

Track System 4 Track, 2 Channel

Head System

Rec/Play Head Hard Metal Alloy(Rotary)

Erase Head Dual Gap Ferrite

Recording/Erasure System AC 105kHz Bias

Motor System

Capstan DC Servo Control

Reel DC

Overall S/N,no NR,"A"weighted

PMD501 PMD502

Normal 51dB 52dB

Chrome 52dB 53dB

Metal 52db 53dB

S/N(Overall),Dolby C NR,"A"Wtd.

PMD502

Normal 67dB

Chrome 68dB

Metal 69dB

Frequency Response, Rec/Play, no NR

PMD501 PMD502

(±3dB, Hz) Normal 25~14k 20~16k

Chrome 25~15k 20~17k

Metal 25~16k 20~18k

Dolby NR effect, CCIR/ARM Wtd.

PMD501 PMD502

NR B 9dB 9dB

NR C 18dB

Output

Line 500mV

Phone(8 ohm) 100mV

Output Impedance

Line 2.2kΩ

Phone 120Ω

Input Sensitivity

Line/Impedance 100mV/47kΩ

Pitch control (PMD502 ONLY) ±15%

Wow & Flutter

W RMS 0.14%

Power supply

Power Requirement 120 VAC 60Hz

PMD501 PMD502

Power consumption 0.17A 0.23A

Dimensions (MAX)

Width 19-1/8 inches (485 mm)

Height 5-1/4 inches (133 mm)

Depth 11 inches (280 mm)

Net Weight 11.5 lbs.(5.2 kg)

These specifications represent design standards. Higher levels of performance can be expected under most conditions.

* Subject to change without prior notice.

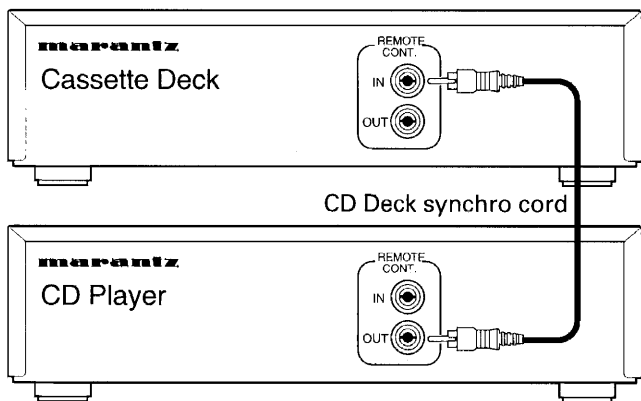
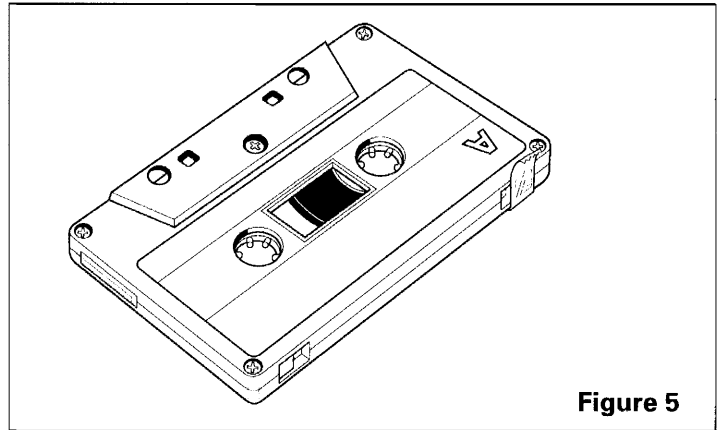
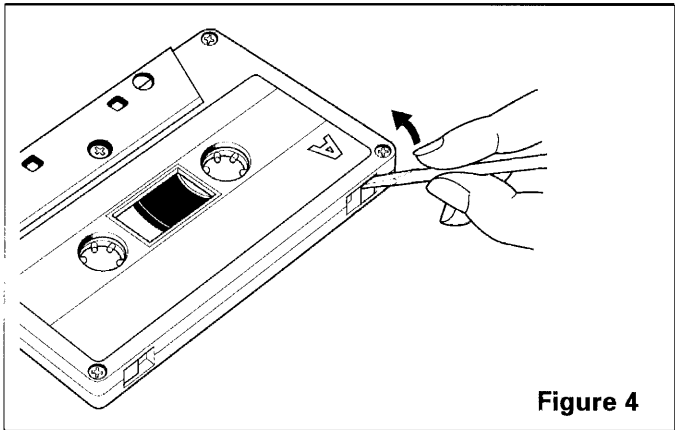
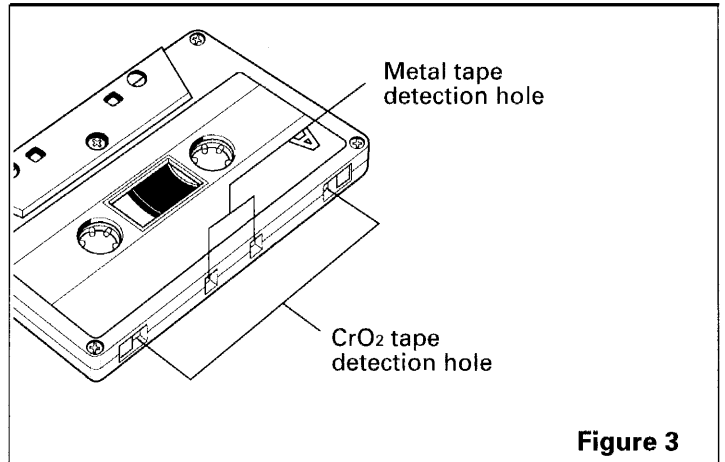
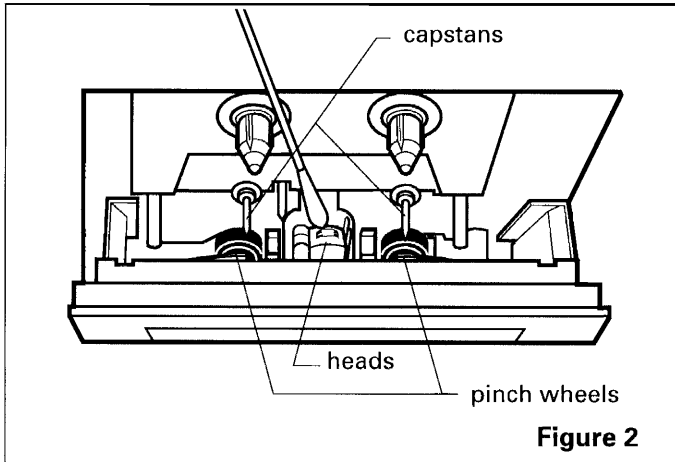

REAR PANEL SIGNAL CONNECTIONS

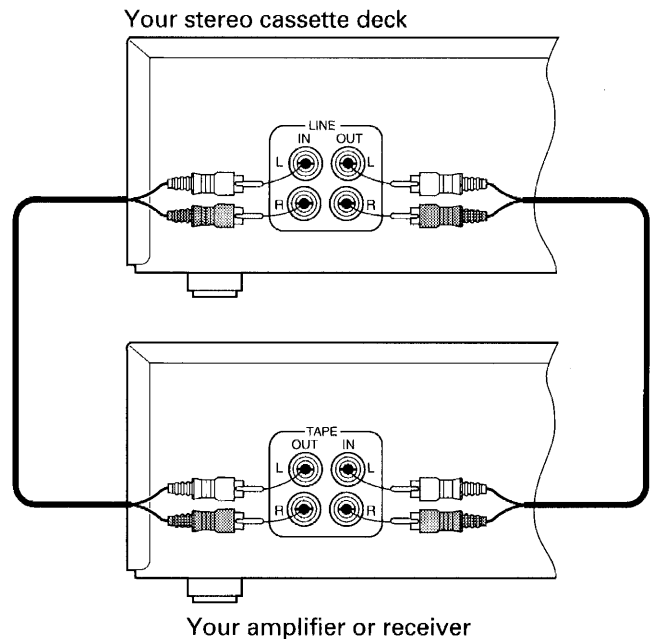

marantz® is a registered trademark.