

MONSTER POWER[®]



PRO 2500

Professional PowerCenter™
with Clean Power™ Stage 2 v.2.1 Filtering

Owner's Manual

TABLE OF CONTENTS

| | Page |
|---|-------------|
| Important Safety Precautions | ii |
| Proper Grounding and Installation Tips | v |
| Introduction | 1 |
| The Design Minds Behind the PowerCenter | 2 |
| Content Checklist | 4 |
| Product Features | 7 |
| Troubleshooting | 11 |
| Frequently Asked Questions | 13 |
| Appendices | |
| Glossary of Power-Related Terms | 15 |

IMPORTANT SAFETY PRECAUTIONS

Please read and observe the following safety points at all times. Failure to do so may cause serious personal injury and/or death.

WARNING – Power Sources

Do not plug this Professional PowerCenter™ into a power outlet that differs from the source indicated for safe use on the PowerCenter. If you don't know the type of electrical power that is supplied to home, studio, or venue, please consult the local power company.

WARNING – Grounding

A. Your Monster PowerCenter has a three-wire grounding-type AC plug (a three-prong plug). This plug is designed to be inserted into a grounding-type outlet only. If this plug doesn't fit directly inside the outlet, do not attempt to force it. If this doesn't work, contact a local electrician to install the proper grounded outlet, or find a proper grounded outlet where you are performing. Never attempt to dismantle the plug in any way (or to alter an extension cord) to make it fit into a two-prong outlet. Do not attempt to defeat the grounding feature by using a 3-to-2 prong adapter.

⚠ WARNING – Proper Cleaning

In general, the only cleaning necessary for your Monster PowerCenter is a light dusting.

Unplug from the wall before cleaning your PowerCenter. Do not use any type of liquid or aerosol cleaners.

⚠ WARNING – Liquid: Avoiding Electrical Shocks

Do not operate your Monster PowerCenter if liquid of any kind is spilled onto or inside the unit.

Contact Monster Power for instructions (see page 22). Do not operate your Monster PowerCenter near rain or any standing water (e.g., puddle, bathtub, kitchen or bathroom sink).

⚠ WARNING – Power Cord Safety

A. When routing your Monster PowerCenter AC power cord, do not place it near heavy foot traffic areas (e.g., hallways, doorways, etc.). Do not create a trip hazard with the power cord.

B. If your power cord's protective jacket begins to rip or fray, exposing the internal wiring, shielding, etc., disconnect it from the power source and discontinue use of the Monster PowerCenter immediately. See the warranty section of this owner's manual (page 18).

⚠ WARNING – Storm Precautions

In the event of a lightning storm, immediately disconnect (unplug) your Monster PowerCenter from its power source. After you've done this, it's not necessary to disconnect any components from your Monster PowerCenter.

⚠ WARNING – No User Serviceable Parts Inside

If, for any reason, your Monster PowerCenter is not operating properly, do not remove any part of the unit (cover, etc.,) for repair. Unplug the unit and consult this owner's manual for warranty and service information.

⚠ CAUTION – Exposure to Heat

Do not expose your Monster PowerCenter to direct sunlight or place it near wall heaters, space heaters, or any enclosed space prone to temperature increase (e.g., car trunk).

PROPER GROUNDING AND INSTALLATION TIPS

CAUTION – Proper Grounding

Monster PowerCenters require a properly grounded 3-wire outlet to protect connected equipment. If your AC outlet is improperly wired (no ground or reverse polarity), the Green “Ground OK” light on the front panel of the Professional PowerCenter PRO 2500 will not light up. In this event, call an electrician to fix the problem in your home’s wiring.

Many older buildings are inadequately wired. It’s very common for a building to be improperly grounded. Building wiring and grounding must conform to applicable NEC (USA) or CEC (Canada) codes. If you’re not sure about your the wiring you are using, have it checked by a qualified electrician.

IMPORTANT NOTE – Proper Power and Protection

To completely deliver clean power and protect your equipment against electrical surges, every wire into or out of your equipment must be connected to an appropriate Monster PowerCenter.

INTRODUCTION

About Monster Power

Since 1979, Monster has provided high performance instrument and speaker cables to performing musicians and recording professionals around the world. In 1998, we introduced Monster Power, a complete line of affordable, audiophile-grade PowerCenters that provided better sound, and complete protection against electrical surges and spikes. Robert Harley and The Absolute Sound magazine said it best, "In my ten years as a reviewer, I've never heard as dramatic an improvement in sound quality for so little money as that rendered by Monster Power's Home Theatre PowerCenter™ HTS 2000." Now, Monster has created a new line of Professional Power Centers for the musician, studio owner, installer, and backline tech. The PowerCenter PRO 2500 reflects Monster's commitment to creating performance-enhancing solutions for music professionals.

Ordinary AC power accessories don't increase the performance of the equipment they power. The PowerCenter's advanced technology and innovative design offers several patented convenience and performance features.

While your new PowerCenter also does an excellent job of protecting your equipment from harmful power surges, its main performance benefit is much more than just surge protection. Our patented Clean Power™ filter circuitry (U.S. Pat. No. 6,473,510 B1) virtually stops noise that goes right through ordinary surge protectors.

There is also more than one type of noise that can degrade connected equipment. Your PowerCenter features revolutionary separate noise isolation between digital and analog filtered outlets. If any noise from components sharing the powerline gets through one Clean Power filter, it will have to go through another filter to get to an adjacent set of outlets. The result is an extremely low noise floor without hum or buzz that allows all of the rich harmonics and tone to come through your performance.

As fellow musicians and audiophiles, we designed your PowerCenter to help achieve the best possible sound. Enjoy!

THE DESIGN MINDS BEHIND THE POWERCENTER



Richard Marsh – There are few experts able to solve the complex problems of AC power. Richard Marsh is one of the illustrious few. He has designed best selling power conditioning components costing more than \$3,000 and now brings his expertise to Monster Power. Richard developed Monster's exclusive Clean Power™ circuitry. He is also responsible for several other groundbreaking designs. Richard's background and research into amplifier and capacitor design led to his development of the Servo-DC feedback concept in power amplifiers – a concept that is used by virtually every amplifier manufacturer today. His status as both the inventor of the MultiCap™ internal bypass capacitor and as the driving force behind the high-end audio balanced circuit design concept has influenced the audiophile community for years. Richard is responsible for some of the high end audio world's most respected product designs, essays and articles, and has contributed to *Fi*, *The Absolute Sound* and *Audio* magazines. He is included in *Who's Who in the West*.



Demian Martin – Demian Martin has been solving complex AC power problems for several years. As a technical consultant for successful paper and steel mills, Demian helped create several innovative AC power solutions. He developed techniques to dramatically improve the efficiency of these factories' high power motor control systems – up to 50,000 watts each – helping them avoid the costly premiums many factories must pay for AC power inefficiency. Demian was also co-founder of Spectral Audio where he designed many breakthrough products such as amplifiers and digital-to-analog converters. He now brings his expertise to Monster Power's elite research and development team.

Noel Lee – Noel is best known for popularizing the concept of high performance audio cable over 20 years ago with his creation of Monster Cable. Originally a laser-fusion design engineer at Lawrence Livermore National Laboratory and later a touring musician, Noel has invented or co-invented 150 patented products and drives the explosive growth of Monster into more than 80 countries worldwide. As a fellow musician, he understands the importance of reliable, safe, clean power, and how it can make or break a performance on stage or in the studio. Noel solicited the advice and input from numerous studio aces when laying the groundwork for the PowerCenter PRO 2500, so every musician, recording engineer, and studio owner could enjoy an affordable power solution that delivered the best possible performance.



And You – The thousands of Famous Monsters and unsung musicians who have given us ideas on how to create new and exciting products. Monster is full of musicians who understand the needs of performing and recording professionals and amateurs alike.

Please help us continue to bring new and exciting products to musicians around the world. Tell us what you like, don't like, or how to improve Monster Products by surfing to: www.monsterpower.com

CONTENT CHECKLIST

Before You Begin

Before you do anything, make sure you have everything you need to enjoy the high performance of your Monster PowerCenter. You'll need the following items to get started:

- 1) This owner's manual.
- 2) Your favorite pen or a computer with internet browser (for registering your warranty information).
- 3) Your Monster Professional PowerCenter PRO 2500.

Rackmounting Your PowerCenter

Use 10/32 screws (not supplied) to fasten your PowerCenter into any standard, 19" wide equipment rack.

NOTE: Monster recommends using protective washers to prevent damaging the faceplate finish.

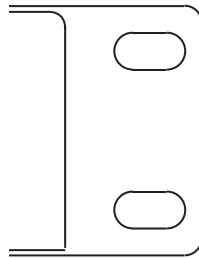

PRO2500 Faceplate Rack "Ear"

Two-Stage Sequential Power-Up/Power-Down for Digital, Analog, and High Current Outlets

Turn on the PowerCenter. The digital and analog outlets are switched, and the high current outlets are timed, providing sequential activation of your components. This gives your digital and analog "front end" equipment a chance to initialize and run any self tests that the manufacturer has programmed. The high current outlets are turned on last after a 6-second delay, preventing a loud thump from getting to your speakers. Power down is in the reverse order to protect your equipment.

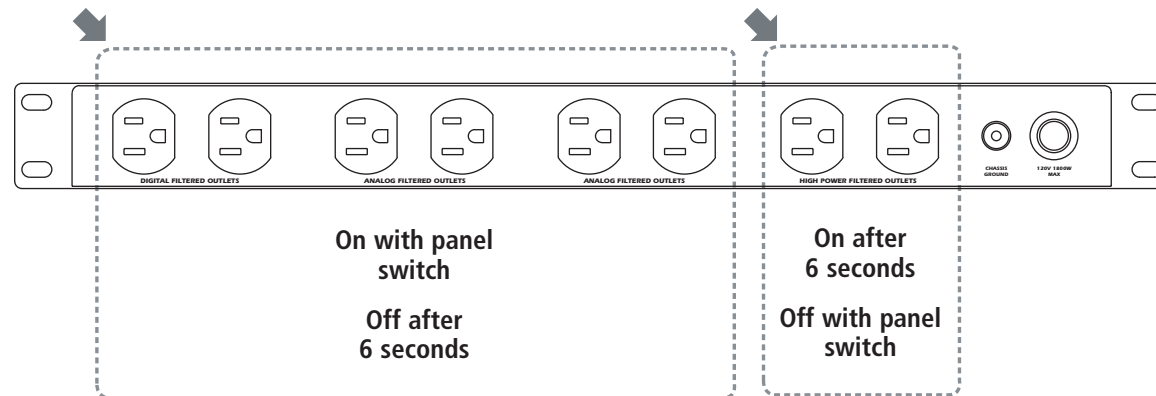

PRO 2500 FEATURES

SEE PAGE 8 FOR DESCRIPTION OF PRODUCT FEATURES

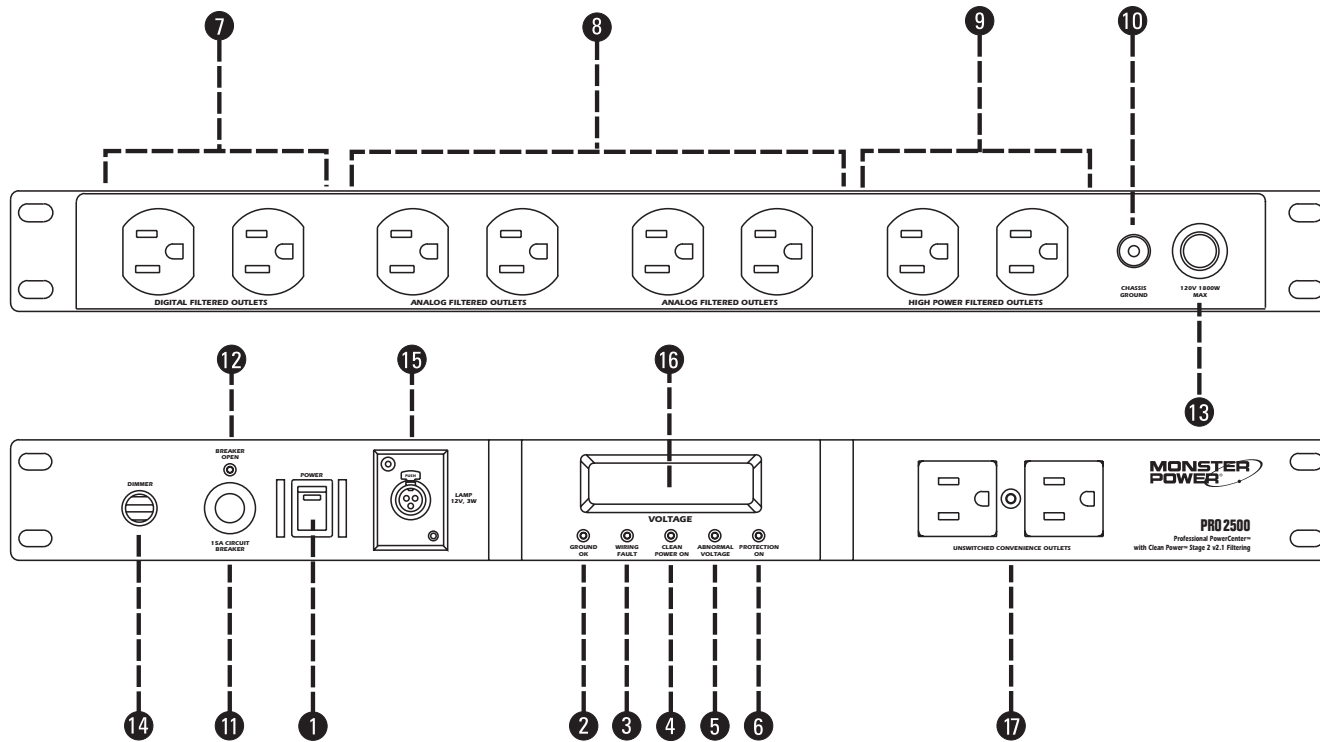

PRO 2500 FEATURES

NUMBERS REFER TO DRAWING ON PAGE 7

- 1. ON/OFF Switch:** Once the PowerCenter is plugged into a grounded 120V outlet, turning the Front Panel switch to the "on" position will provide AC power sequentially to the components plugged into the PowerCenter's Switched, and Switched (Timed) outlets. Turn "off" this switch to power down the rear outlets.
- 2. Ground OK:** When this LED is On, the PowerCenter is plugged into a properly grounded 120V AC power outlet. If the LED is Off, unplug the PowerCenter immediately. **Monster Cable® is not responsible for equipment damage due to improper grounding of your residential or commercial outlets.**
- 3. Wiring Fault:** This LED indicates if the Line and Neutral wires inside the wall outlet are reversed. If this LED is on, unplug the unit immediately and consult your electrician.
- 4. Clean Power On:** This LED indicates that the PowerCenter is providing filtered AC power to all connected components.
- 5. Abnormal Voltage:** When this LED is On, the PowerCenter warns of unstable power conditions (over 130 VAC or under 90 VAC).
- 6. Protection On:** When this LED is On, Monster Power Surge Protection Circuitry is functioning properly. If this LED is off, Monster Power Surge Protection Circuitry has malfunctioned. If the light is off, unplug the PowerCenter immediately. See warranty information for details on how to return damaged equipment to Monster Power (page 18).

NUMBERS REFER TO DRAWING ON PAGE 7

7. Digital Filter (Switched) Outlets: These outlets have a special filter circuit that is designed to reduce AC supply interference to your digital components (such as effects, CD Players, and Computers). They also isolate the rest of your system from noise generated by the digital components themselves.

8. Analog Audio Filter (Switched) Outlets: These outlets have a special filter circuit that reduces audible noise in your analog components (mixers, etc).

9. High Current Filter (Timed) Outlets: These outlets have a special filter circuit designed to handle high current components like power amplifiers.

IMPORTANT NOTE It does not harm digital components, analog components or amplifiers to be connected to the "wrong" filter section. However, for the best possible performance, we recommend plugging in digital to digital, analog to analog and amps to high current filter outlets.

10. Gold-Plated Ground Post: Provides a ground reference point for any ungrounded components.

11. Thermal Circuit Breaker: Protects the PowerCenter from power overload.

NUMBERS REFER TO DRAWING ON PAGE 7

12. Breaker Open: When this LED is on, the thermal circuit breaker has tripped, due to overload, to protect your equipment. Find the reason for overload, correct it, and press the breaker in to reset.

13. Ultra-High Current PowerLine™ 200 AC Power Cable: High-density, double-shielded AC Power cord is specially designed to maximize power transfer to ultra-high power components such as amplifiers.

14. Dimmer: This knob controls the flexible MonsterLight; Push On/Push Off, clockwise brighter, counter-clockwise dimmer. The MonsterLight can be turned on even when the unit is switched off.

15. 12V XLR Lamp Socket: Provides 12 volts (pin 2) to the flexible Monster Light.

16. Numerical Display: Three-character 1-line LED numeric display indicates the AC voltage the unit is receiving from the wall.

17. Unswitched Convenience Outlets: These outlets provide an easy front panel connection that is “always on,” even when the PowerCenter is switched off. These outlets provide filtered power.

TROUBLESHOOTING

PROBLEM – The PowerCenter is not receiving power.

Possible Cause #1

The PowerCenter is not turned On.

Possible Solutions

- *Turn the PowerCenter switch On.*
- *Make sure the PowerCenter's AC power plug is plugged into a properly grounded 120V wall outlet.*
- *In some cases, a wall switch may need to be thrown to make the wall plug come alive. Try turning on the light switches located near the wall unit powering the PowerCenter.*

Possible Cause #2

Too many devices drawing too much power are connected, causing an overload, throwing the Thermal Circuit Breaker.

Possible Solutions

- *Press the PowerCenter Thermal Circuit Breaker button in to reset. Please allow 10 minutes before attempting to reset. If you reset too soon, the breaker may prematurely sense power overload and not allow unit to operate.*

TROUBLESHOOTING

Possible Cause #3

The PowerCenter cord is plugged into an outlet on the back of one of your components and the component is not turned On.

Possible Solutions

- *Turn the component power On.*

NOTE: For the best possible performance, plug the PowerCenter into a wall outlet, not another component.

PROBLEM – Speakers emit a humming or buzzing noise.

Possible Cause

The PowerCenter is sharing AC power with equipment that is not properly grounded.

Possible Solution

- *Connect your PowerCenter to a properly grounded outlet.*

FREQUENTLY ASKED QUESTIONS

Q. What is the importance of component-to-component filtering?

A. With the Monster PowerCenter, AC power must first go through a segment of noise filters that isolate your equipment from noise on the AC power line. Most manufacturers' battle against line noise stops there. The next crucial step of noise filtering must occur between components. Our patented component-to-component noise filtering is one of the PowerCenter's incredibly innovative features because it protects components from degrading each other's performance via their own special type of interference. The PowerCenter outlets are all directly connected, so the noise that's generated by a particularly noisy component (digital components like samplers are infamous for this) will attempt to get onto other components. It will not, however, because it must go through a specialized filter to get to an adjacent outlet, and noise is eliminated for the best possible performance.

Q. What is the importance of separate filtering for analog and digital?

A. The nature of the analog and digital signals are very different. Each application generates a different kind of noise and is sensitive to different types of noise. Digital components generate a wide band of clock frequency-related interference. Audio components generate a narrow band of interference. Monster's patented analog and digital filters are optimized for each application, for maximum noise filtering.

Q. Does it matter which outlets I plug my components into?

A. Yes. Each group of outlets is specifically designed to protect and maximize performance of ONLY the component types they are intended to power. For example, an amplifier is high current and an effects processor is not. Each gets separate noise filtering to accommodate their inherent needs and differences.

Q. Will it harm a component to plug it into an outlet that it is not designated to power, like a high current amplifier into an analog outlet?

A. No. However, you may not realize the full performance potential of the PowerCenter. If you were to plug an amplifier into an analog outlet, for example, you may experience a thumping noise when you turn on the PowerCenter. The amplifier is a high current device that ideally should be plugged into a PowerCenter Timed outlet (which the analog outlet is not) to avoid this problem.

APPENDIX A

Glossary of Power-Related Terms

Audio Noise: In the audio-frequency range, any electrical disturbance introduced from a source extraneous to the signal.

Alternating Current (AC): A flow of electricity which reaches maximum in one direction, decreases to zero, then reverses itself and reaches maximum in the opposite direction. This cycle is repeated continuously.

Amp: A common abbreviation for Ampere. Ampere is a unit of electrical current or rate of flow of electrons.

CSA: A common abbreviation for Canadian Standards Association. CSA has developed over 200 standards, including several for electrical and electronic products.

Clean Power™: Noise filtering designed exclusively for Monster Power products by renowned engineer/inventor Richard Marsh. Filters out unwanted interference caused by RFI, EMI, and component-generated noise, so components plugged into a PowerCenter can deliver maximum performance without noise entering their signal path.

Conducted Noise: Any unwanted electrical signal conducted on the power lines supplying the equipment.

Current: The movement of electrons through a conductor.

Digital Noise: In the digital-frequency range, any electrical disturbance introduced from a source extraneous to the signal.

Direct Current (DC): A flow of continuous electric current in one direction.

Electromagnetic Interference (EMI): Electromagnetic phenomena in which various appliances and components generate interference that can contribute to a degradation in performance of an electronic receiver or system.

Filter: A selective network of resistors, inductors, or capacitors which offers comparatively little opposition to certain frequencies, while blocking or attenuating other frequencies.

Ground: A point in an electrical system that has zero voltage. Usually, the chassis of an electrical component is at ground potential and thus serves as the return path for signals as well as for power circuits.

Hertz (Hz): A unit of frequency equal to one cycle per second.

Joule Rating: A measurement of how much surge can be absorbed by a surge suppressor device. The higher the joule rating, the more surge it can absorb.

Peak Current: The maximum current which flows during a complete cycle without permanent change in breakdown ratings or published life specifications.

Power: The energy dissipated into an electrical or electronic circuit or component that is conducting either AC or DC. Electrical energy developed to do "work" such as the voltage from an amplifier used to drive a speaker.

Power Line: Two or more wires conducting electric power from one location to another.

Radio Frequency Interference (RFI): Any electrical signal capable of being propagated into and interfering with the proper operation of electrical or electronic equipment. The frequency range of such interference may be taken to include the entire electromagnetic spectrum.

Spike: An abrupt transient which comprises part of a pulse, but exceeds its average amplitude considerably.

Surge: A large, sudden change of voltage or current, usually caused by the collapse of a magnetic field or by a shortened or opened circuit element.

Surge Protector: A device which protects component circuitry from high alternating voltage peaks or transients.

Transient: A momentary surge on a signal or power line which may cause component breakdown and failure.

UL: A common abbreviation for Underwriters' Laboratories, Inc., a corporation supported by some underwriters for the purpose of establishing safety standards on types of equipment or components.

Volt (V): The unit of measurement of electromotive force. One volt is equivalent to the force required to produce a current of one ampere through a resistance of one ohm.

Voltage: Electrical pressure—i.e., the force which causes current to flow through an electrical conductor.

Voltage Rating: The maximum voltage which an electrical device or component can sustain without breaking down.



Monster, LLC
7251 Lake Mead Blvd West, 3rd Floor • Las Vegas, NV 89128 • USA
Visit us on the web at: monsterpower.com

The Monster Power Professional PowerCenter™ PRO 2500 is protected under U.S. Pat. No. 5,589,718. Other Patents Pending.

"Monster" "Monster Cable" "Monster Power" "Clean Power" and "PowerCenter" are registered and unregistered trademarks of Monster, LLC.

© 2003 Monster, LLC