



Quam

LOUDSPEAKER ASSEMBLIES

SYSTEM 6VPS

SURFACE MOUNT

**Stainless Steel, Vandal Resistant,
Paging Horn Speaker System**

GENERAL DESCRIPTION

The SYSTEM 6VPS is a complete loudspeaker assembly with a double re-entrant horn, compression type loudspeaker, 16W- 25/70V transformer, BS8VPS baffle (stainless steel, vandal resistant, powder-coated white) and a SE1WVPS surface mount enclosure (stainless steel, vandal resistant, powder-coated white). Mounting hardware is #8-32 'pin-in-torx'.

INTENDED USE

Indoor or protected outdoor environment

Installation.....Horizontal or vertical surface mount

Program Material.....Paging and signal tones

AUDIO SPECIFICATIONS

Average Sensitivity.....110 dB SPL, 1W/ 1M

Loudspeaker Power Rating.....16W RMS, EIA 426A Standard

Calculated Output.....121dB SPL, 5W/ 1M

Magnet Type & Weight.....BeFe Ceramic, 10 oz. Nominal

Frequency Response.....350Hz - 10 kHz EIA 426A Standard

Nominal Coverage Angle.....90° Included Angle, -6 dB / 2 kHz, half space

Audio Connection.....7" color-coded pigtails, pre-cut



SYSTEM COMPONENTS

Loudspeaker.....H16

Transformer.....Integral to unit

25/70V 16W-5 tap Color Coded Leads
(16W, 8W, 4W, 2W, 1W)

Baffle.....BS8VPS - stainless steel, vandal resistant, powder-coated white

Enclosure.....SE1WVPS - Square, stainless steel, vandal resistant,
powder-coated white, interior and exterior use

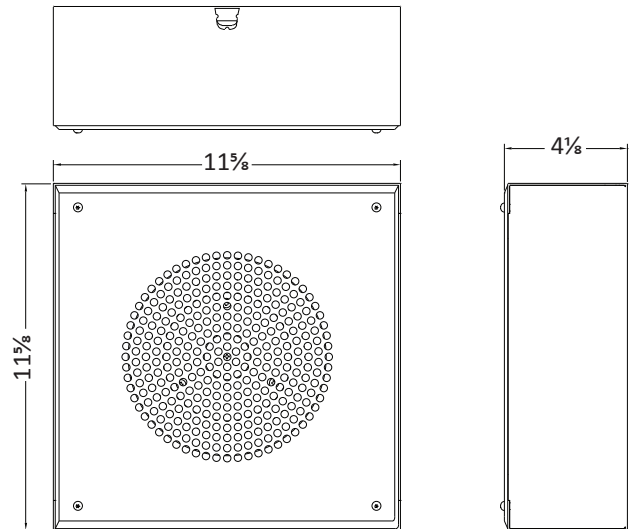

Recommended construction sequences, installation instructions, and A&E Specifications are available in various formats in the QUAM Architects' and Engineers' Resources section on the web at: www.QuamSpeakers.com

© 2013 Quam-Nichols Company Quam-Nichols reserves the right to make changes and/or improvements to its products at any time and without notice.

