

REVEAL™

VADDIO™ IN-WALL™ ARCHITECTURAL SERIES CAMERAS

Model Numbers:

999-6925-000: Clear Glass - HD-18 Quick-Connect SR Interface - North American Version

999-6925-001: Clear Glass - HD-18 Quick-Connect SR Interface - International Version

999-6926-000: Clear Glass - Quick-Connect DVI/HDMI SR Interface - North American Version

999-6926-001: Clear Glass - Quick-Connect DVI/HDMI SR Interface - Euro & UK Cord Set

999-6935-000: Smart Glass - HD-18 Quick-Connect SR Interface - North American Version

999-6935-001: Smart Glass - HD-18 Quick-Connect SR Interface - International Version

999-6936-000: Smart Glass - Quick-Connect DVI/HDMI SR Interface - North American Version

999-6936-001: Smart Glass - Quick-Connect DVI/HDMI SR Interface - International Version

999-1105-022: Quick-Connect CCU Controller Option for REVEAL



REVEAL IN-Wall PTZ Architectural Series Cameras

Overview:

Vaddio's REVEAL IN-Wall PTZ cameras are the first in Vaddio's Architectural Series robotic camera products. The REVEAL was designed to blend into high-end videoconference and presentation rooms and the aesthetics match closely to that of flat screen monitors in shape, color and finish. The REVEAL uses a Smart Glass technology framing system which when activated, frosts the front glass frame and shuts off the camera so there is no mistake that the REVEAL is on or off. This ensures that conference participants know what state the camera is in (on or off) which is important in the high-end room system designs.



REVEAL IN-Wall PTZ Smart Glass - Frosted/OFF

The REVEAL Smart Glass is composed of a liquid crystal matrix, laminated between ITO coatings and glass. When the camera is turned on, the glass switches to its clear state, the camera homes and is ready for use. Vaddio also offers a clear glass version of the REVEAL system.



REVEAL IN-Wall PTZ Camera with Clear Glass

Key features include the use of a 1/3-type, 1.3 Megapixel CCD image sensor for crisp clear images, 1.8 LUX rating and 18X glass optical zoom lens which works well in small or large rooms and lower light environments. The REVEAL enclosure uses the depth of the wall cavity eliminating the cameras extension into the room and the REVEAL works with the Vaddio HSDS™ cabling standard for video, power and control over Cat. 5 cabling. The REVEAL looks as good as it does on the inside as the outside and provides superior HD video images for wide range of HD applications.

Intended Use:

Before operating the system, please read the entire manual thoroughly. The system was designed, built and tested for use indoors, and with the provided power supply. The use of a power supply other than the one provided or outdoor operation has not been tested and could damage the camera and/or create a potentially unsafe operating condition.

Save These Instructions:

The information contained in this manual will help you install and operate your system. If these instructions are misplaced, Vaddio keeps copies of Specifications, Installation, User Guides and the most pertinent product drawings on the Vaddio website. These documents can be downloaded from www.vaddio.com free of charge.

Important Safeguards:

Read and understand all instructions before using. Do not operate any device if it has been dropped or damaged. In this case, a Vaddio technician must examine the product before operating. To reduce the risk of electric shock, do not immerse in water or other liquids and avoid extremely humid conditions.



Use only the power supply provided with the REVEAL system. Use of any unauthorized power supply will void any and all warranties.



Please do not use "pass-thru" type RJ-45 connectors. These pass-thru type connectors do not work well for professional installations and can be the cause of intermittent connections which can result in the RS-232 control line failing and locking up, and/or compromising the HSDS™ differential video. For best results please use standard RJ-45 connectors and test all cables for proper pin-out prior to termination.

Unpacking:

Carefully remove the complete REVEAL camera assembly and all of the hardware from the packaging. The exploded view drawing below details the parts included. Please verify that all the parts are included.

- 1) One(1) REVEAL Camera Module and Enclosure
- 2) Four (4) Spiral Wall Anchors
- 3) Four (4) #8-32 x 1.25" Sheet Metal Screws
- 4) Four (4) 0.5" OD x 0.25" ID x 1.25" White Nylon Spacers
- 5) One (1) Face Frame Cover for Enclosure
- 6) Four (4) 3/4" OD x 3/4" Tall Brushed Aluminum Stand-offs
- 7) Four (4) 3/4" OD Thin (clear) Nylon Washers
- 8) Four (4) 1/4" x 20 x 1.0" Threaded Posts
- 9) One (1) Glass Plate (either dual pane smart glass or clear glass - depending on the camera ordered)
- 10) Four (4) 3/4" OD Nylon Washers with Centering Ridge
- 11) Four (4) 3/4" OD Brushed Aluminum Post Caps

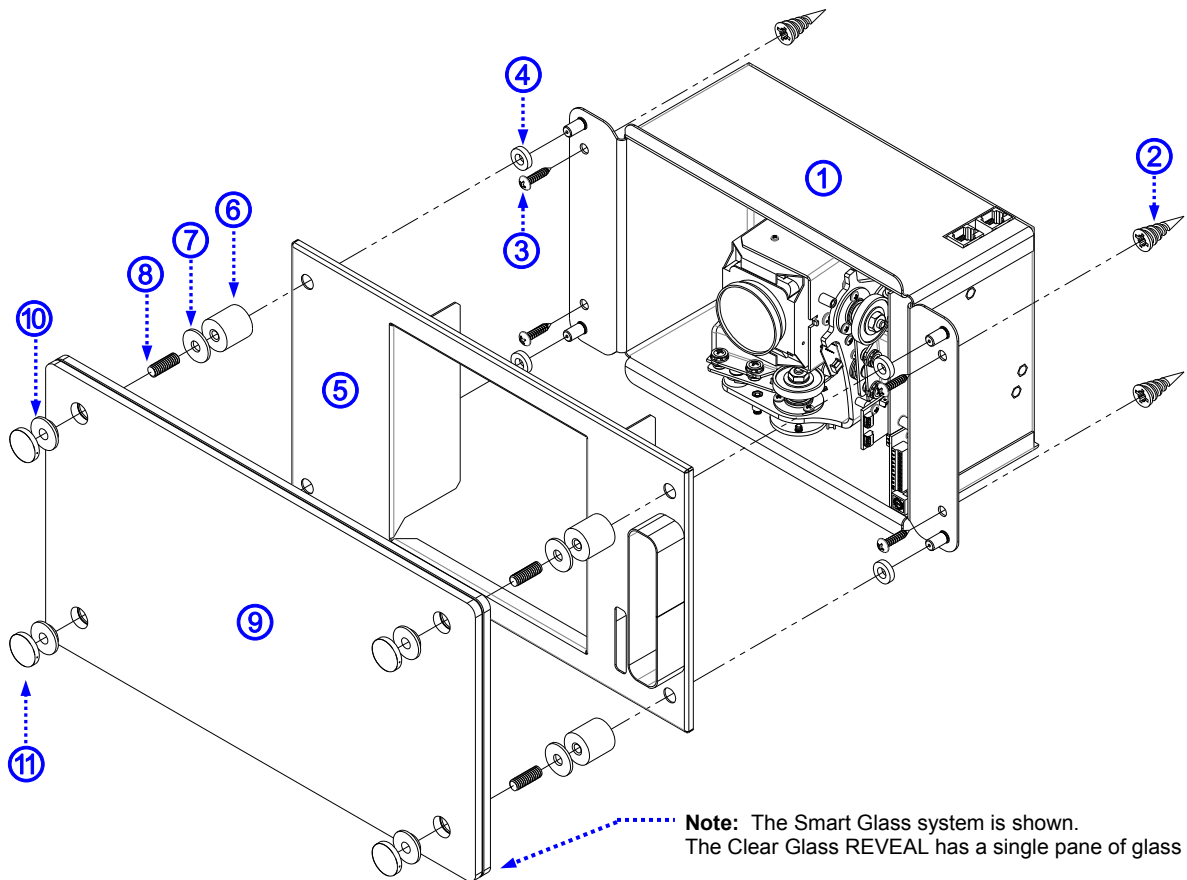

Packages:

Depending on the package ordered, the contents of the system differ. There are two (2) glass types (Clear and Smart Glass), (2) Quick-Connect options (HD-18 Quick-Connect SR Interface and Quick-Connect DVI/HDMI SR Interface), two (2) geographic options (North America and International) and finally an option for the Quick-Connect CCU Controller that works with any system aforementioned above. The REVEAL product line is flexible with many options. The following information regarding the contents of each of the packages will cover all the combinations available.

Packages (continued):

REVEAL 999-6925-000 - Clear Glass - North America includes:

- One (1) Complete REVEAL Camera Module Assembly (see page 4)
- One (1) **HD-18 Quick-Connect - SR Interface**
- One (1) 24VDC, 2.0A PowerRite™ Switching Power Supply
- One (1) North American AC Cord Set
- One (1) EZCamera Control Adapter
- One (1) Vaddio IR Remote Control and Manual
- One (1) Installation Guide (342-0059)



HD-18 Quick-Connect - SR Interface
1/3-Rack Size

REVEAL 999-6925-001 - Clear Glass - International includes:

- One (1) Complete REVEAL Camera Module Assembly (see page 4)
- One (1) **HD-18 Quick-Connect - SR Interface**
- One (1) 24VDC, 2.0A PowerRite Power Supply
- One (1) Euro AC Cord Set
- One (1) UK AC Cord Set
- One (1) EZCamera Control Adapter
- One (1) Vaddio IR Remote Control and Manual
- One (1) Installation Guide (342-0059)



REVEAL 999-6926-000 - Clear Glass - North America includes:

- One (1) Complete REVEAL Camera Module Assembly (see page 4)
- One (1) **Quick-Connect DVI/HDMI - SR Interface**
- One (1) 24VDC, 2.0A PowerRite Switching Power Supply
- One (1) North American AC Cord Set
- One (1) EZCamera Control Adapter
- One (1) Vaddio IR Remote Control and Manual
- One (1) Installation Guide (342-0059)



Quick-Connect DVI/HDMI - SR Interface
1/2-Rack Size

REVEAL 999-6926-001 - Clear Glass - International includes:

- One (1) Complete REVEAL Camera Module Assembly (see page 4)
- One (1) **Quick-Connect DVI/HDMI - SR Interface**
- One (1) 24VDC, 2.0A PowerRite Power Supply
- One (1) Euro AC Cord Set
- One (1) UK AC Cord Set
- One (1) EZCamera Control Adapter
- One (1) Vaddio IR Remote Control and Manual
- One (1) Installation Guide (342-0059)



REVEAL 999-6935-000 - Smart Glass - North America includes:

- One (1) Complete REVEAL Camera Module Assembly (see page 4)
- One (1) **HD-18 Quick-Connect - SR Interface**
- One (1) 24VDC, 2.0A PowerRite™ Switching Power Supply
- One (1) North American AC Cord Set
- One (1) EZCamera Control Adapter
- One (1) Vaddio IR Remote Control and Manual
- One (1) Installation Guide (342-0059)



HD-18 Quick-Connect - SR Interface
1/3-Rack Size

REVEAL 999-6935-001 - Smart Glass - International includes:

- One (1) Complete REVEAL Camera Module Assembly (see page 4)
- One (1) **HD-18 Quick-Connect - SR Interface**
- One (1) 24VDC, 2.0A PowerRite Power Supply
- One (1) Euro AC Cord Set
- One (1) UK AC Cord Set
- One (1) EZCamera Control Adapter
- One (1) Vaddio IR Remote Control and Manual
- One (1) Installation Guide (342-0059)



Packages (continued):

REVEAL 999-6936-000 - Smart Glass - North America includes:

- One (1) Complete REVEAL Camera Module Assembly (see page 4)
- One (1) **Quick-Connect DVI/HDMI - SR Interface**
- One (1) 24VDC, 2.0A PowerRite Switching Power Supply
- One (1) North American AC Cord Set
- One (1) EZCamera Control Adapter
- One (1) Vaddio IR Remote Control and Manual
- One (1) Installation Guide (342-0059)



Quick-Connect DVI/HDMI - SR Interface
1/2-Rack Size

REVEAL 999-6936-001 - Smart Glass - International includes:

- One (1) Complete REVEAL Camera Module Assembly (see page 4)
- One (1) **Quick-Connect DVI/HDMI - SR Interface**
- One (1) 24VDC, 2.0A PowerRite Power Supply
- One (1) Euro AC Cord Set
- One (1) UK AC Cord Set
- One (1) EZCamera Control Adapter
- One (1) Vaddio IR Remote Control and Manual
- One (1) Installation Guide (342-0059)



Optional Quick-Connect CCU Controller:

The Quick-Connect CCU controller can be used with any of the REVEAL packages listed above. This CCU Controller differs from the original Quick-Connect CCU in that it does not provide power to the REVEAL camera, nor does it have the HSDS™ differential video I/O. The power and video are handled by the HD-18 Quick-Connect - SR Interface and the Quick-Connect DVI/HDMI - SR Interface. The Quick-Connect CCU Controller works in conjunction with the Control I/O of each of the SR Interfaces allowing image control including Detail (sharpness) Color (red and blue gain), White Balance (auto/manual), Iris(auto/manual), Gain, Pedestal, Chroma, Gamma, Knee and allows for three (3) preset scenes.

Quick-Connect CCU Controller for REVEAL IN-Wall Series Cameras - Front Panel (controls covered later in the manual)



Quick-Connect CCU Controller Rear Panel (I/O and controls covered later in the manual)



The 999-1105-022 System Includes:

- One (1) 998-1105-022 Quick-Connect CCU Controller for REVEAL IN-Wall Series Cameras
- One (1) 12 VDC, 1.0 Amp Switching Power Supply
- One (1) North American AC Cord Set
- One (1) Euro AC Cord Set
- One (1) UK AC Cord Set
- One (1) Manual

REVEAL Installation Instructions:

Step 1:

Read this manual before starting the installation. There are several things to consider before mounting an architectural camera like the REVEAL.



When locating the REVEAL, consider camera and meeting participant viewing angles, lighting conditions, possible line of site obstructions and check for in-wall obstructions where the camera is to be mounted. Pick a mounting location to optimize the performance of the camera. Avoid locating lighting elements directly above the REVEAL camera.

The REVEAL system was designed to use the wall cavity of a 2" x 4" (1.5: x 3.5") stud with a 1/2" to 5/8" drywall. For wall systems that use a lesser depth stud, a simple extension frame can be fabricated and finished by the integrator or the owner's contractors to support the REVEAL system.

Step 2:

Prior to starting work, please review and verify the contents of the system that was purchased (see pages 4 through 6). Please contact Vaddio Tech Support if any parts are missing. It is difficult to install an incomplete system.

Step 3:

Carefully measure the position of the camera enclosure and mark the drywall accordingly. The size of the wall opening should be 6.0" tall x 8.75" wide a small 1/4" tall notch can be cut in the drywall in order to more easily allow the camera enclosure to slip into the wall after the Cat. 5 cables are connected (see diagram below). Check the wall for studs before cutting the drywall. In some cases, part of a stud may require removal and this should be done by qualified personnel.



Use an accurate level to position the enclosure opening and trace a line to fit the back of the enclosure leaving a 1/4" tall notch above the RJ-45 connectors to help ease the camera inside the wall. The face frame will cover the 1/4" notch.

Cut this area out only after verifying that no studs or obstructions exist behind the drywall.

Cut the hole to 6.0" tall x 8.75" wide as stated above.

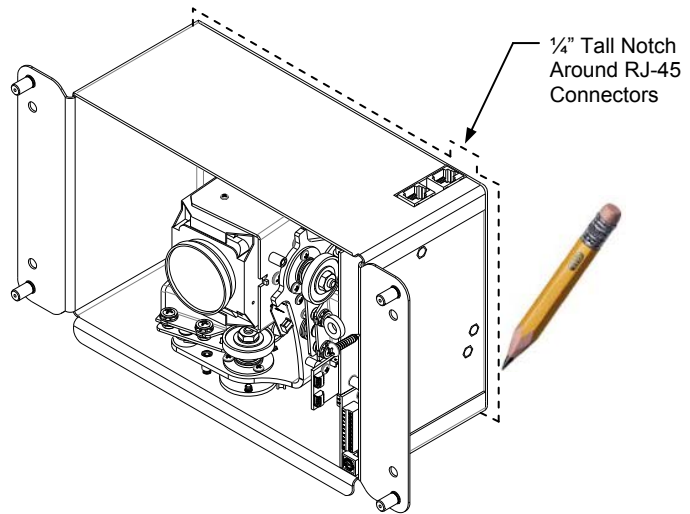

Step 4:

Carefully cut the drywall. Tape the edges of the cut drywall with masking tape to keep the gypsum dust from infiltrating the camera enclosure and making a dastardly and significant drywall mess. Ease the camera into the wall opening and check for fit. Using the level, position the camera enclosure into the hole and mark the holes for the spiral wall anchors and screws.



Step 5:

Remove the camera enclosure from the wall and install the spiral wall anchors on the marks drawn in Step 4.

Step 6:

The REVEAL System uses two (2) Cat. 5e cables. One Cat. 5e cable will to power the camera and return HSDS video signals, and the 2nd Cat. 5e cable will handle the RS-232 control signals. Please TEST and label the POWER/VIDEO and the CONTROL cables accordingly.

On the bottom of the camera, remove the Pan locking screw as indicated on the right. The purpose of the screw is to hold down the pan/tilt mechanism securely during shipment. Please do not connect power to the REVEAL before removing the screw

Remove the pan locking screw prior to connecting power to the REVEAL

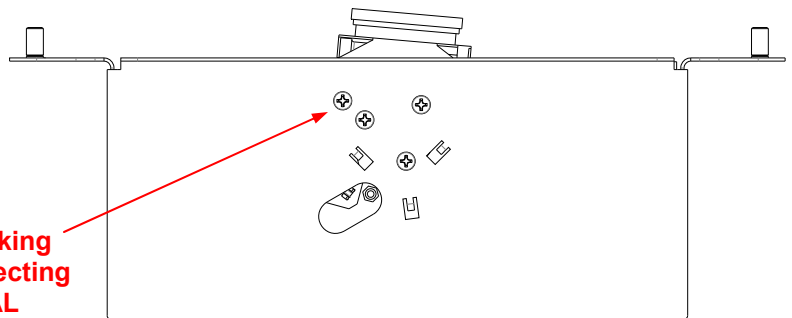

Route two (2) labeled Cat. 5e cables into the wall cavity and through the opening in the drywall. Plug the POWER/VIDEO cable into the RJ-45 jack marked EZCAMERA POWER & HD VIDEO and plug the CONTROL RJ-45 into the RS-232 & IR OUT jack (see below). At the Quick-Connect system, connect the corresponding Cat. 5e cables to the POWER & HD VIDEO port and the RS-232 OUT port. Please do not cross-connect these cables, instead please label the cables and avoid the “trial and error” connection technique. **TEST THE CAMERA AT THIS POINT TO ENSURE THE REVEAL WORKS PROPERLY.** (Refer to the Switch Settings section for HD video output resolutions and dip switch settings on page 11).

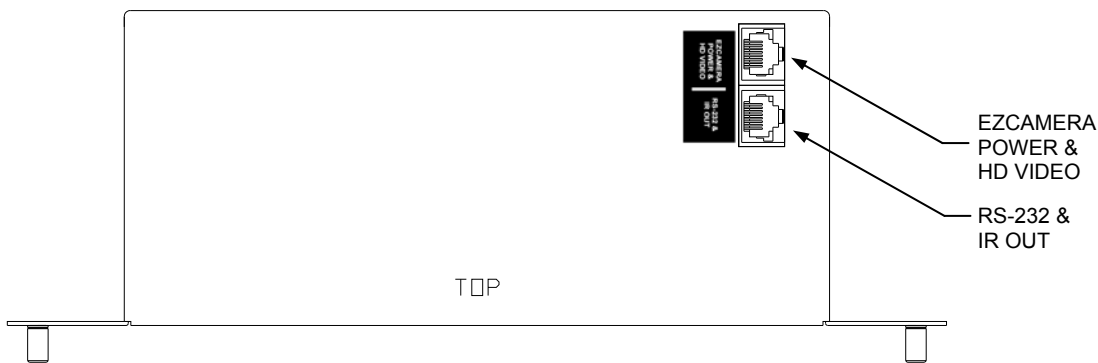

Step 7: Ease the Camera Module back into the wall opening with the connected Cat. 5e cables as illustrated below:

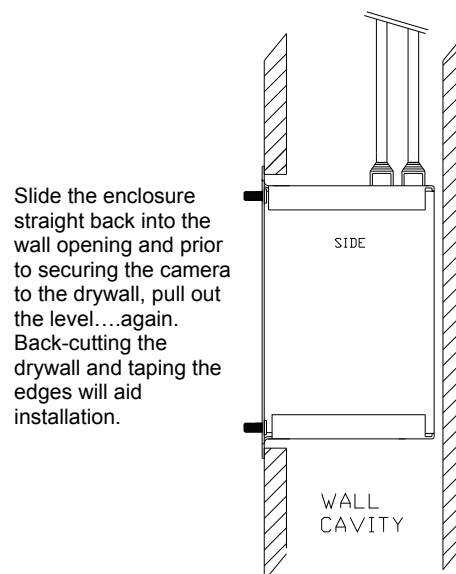
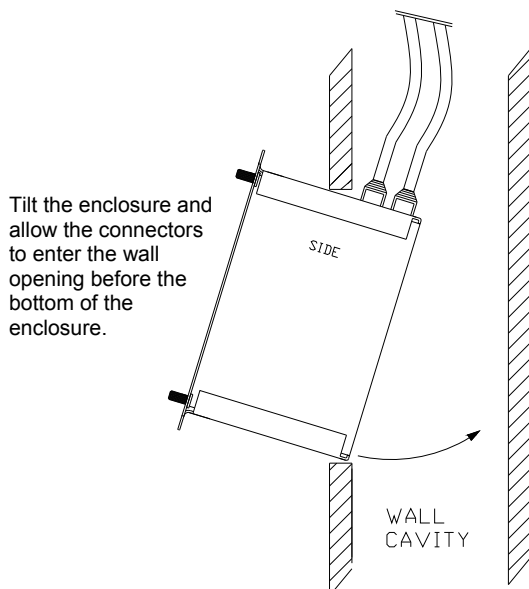

Step 8:

Insert the four (4) #8-32 x 1.25" sheet metal screws into the previously installed spiral wall anchors but do not tighten completely. Use the level and adjust the enclosure so that the system is both level and plumb, then tighten the screws.



Step 9:

Apply the 1/2" OD x 1/4" ID x 0.125" white nylon spacers over the 1/4"-20 PEM posts attached to the enclosure's mounting flanges.



STEP 10:

To install the Face Frame Cover, first connect the 4-Wire IR/LED lead with the white connector to the camera control board and connect the 2-Wire Smart Glass lead with the black connector to the control board as shown.

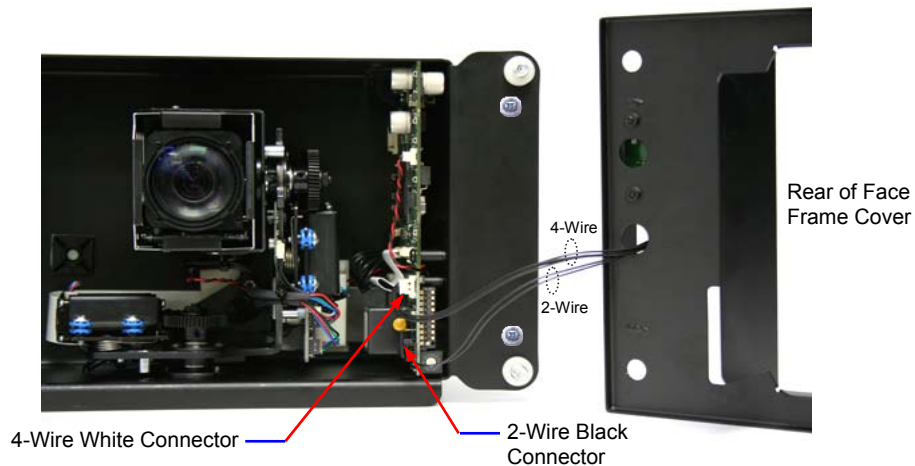

Step 11:

After the connections are made in Step 10, attach the Front Face Cover over the 1/4"-20 posts and carefully tuck the extra wires length of the IR/LED and Smart Glass leads along the side of the circuit boards and behind the vertical cover fins of the face frame.



Step 12:

Attach the four (4) 3/4" OD x 3/4" tall, brushed aluminum stand-offs over the 1/4"-20 posts and tighten snugly by hand. Screw in the four (4) 1/4" x 20 x 1.0" threaded posts into the 3/4" brushed aluminum stand-offs with the Allen (hex) wrench receptacle facing out. Slip the four (4) 3/4" OD thin (clear) nylon washers over the threaded posts. The connector for the Smart Glass is on the circuit board inside the race track shaped front bezel housing on the right hand side of the face frame cover. See page 11 for rotary and dip switch settings and set the switches to the desired position now.



Step 13: For Smart Glass Only

From the back of the Smart Glass, there are two (2) wires that terminate on a black 2-wire connector. This cable is connected to the Smart Glass PCB connector.

NOTE: Skip this step when using the Clear Glass model (since there are no wires on the clear glass).

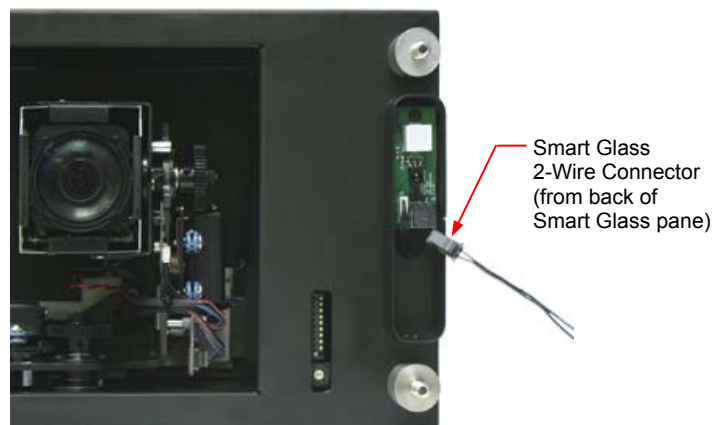

Step 14:

Place the glass over the exposed 1/4"-20 posts. The Clear Glass model has a single pane of glass while the Smart Glass model has a double glass pane with the liquid crystal matrix sandwiched between. The 1/4"-20 posts can be screwed in all the way for the Clear Glass, but the Smart Glass, the 1/4"-20 posts will need to be screwed out slightly to protrude through the double pane glass. Put the four (4) 3/4" OD nylon washers with centering ridge (ridge toward the camera) and attach the four (4) 3/4" OD brushed aluminum post caps. This concludes the installation of the REVEAL IN-Wall PTZ Camera into the wall cavity.



Camera Switch Settings:

There is a 16-position rotary switch that selects the video output resolution of the REVEAL camera and a 10-position dip switch that sets other functions such as the IR remote control frequency and test bars on/off. The placement of the Switch Setting Label is behind the black border masking on the glass pane as shown below.

Front View - Behind Black Border Mask

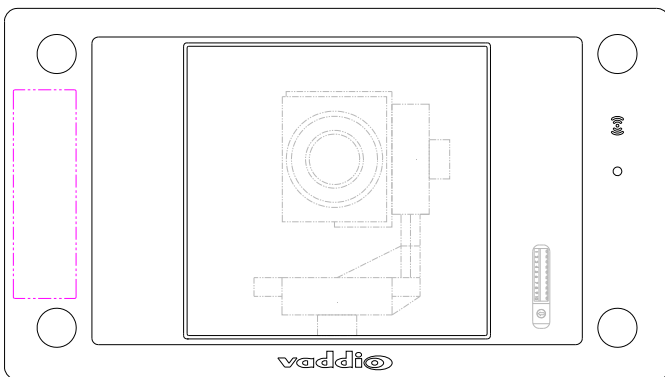

Rear View - Remove Glass to Read and Change Settings as Needed

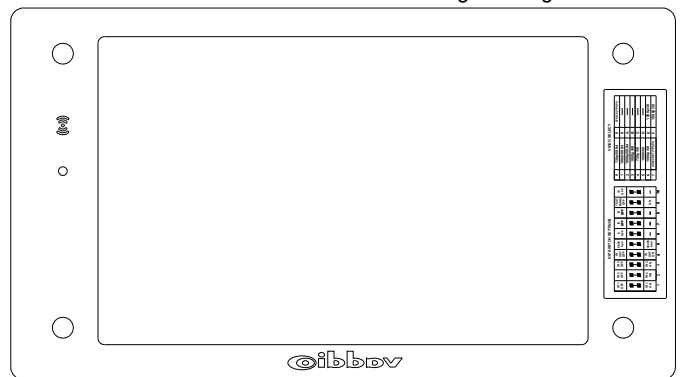

Switch Setting Label:
Set to required settings in Installation Step 6.

DIP SWITCH SETTINGS										VIDEO SELECT			
IR 1 OFF	IR 2 OFF	IR 3 OFF	IR OUT OFF	9600 bps	6 OFF	6 OFF	8 OFF	TEST BARS OFF	10 OFF	0	720p/59.94	8	576i/25 (YPbPr)
■	■	■	■	■	■	■	■	■	■	1	1080i/59.94	9	---
■	■	■	■	■	■	■	■	■	■	2	1080p/59.94	A	---
■	■	■	■	■	■	■	■	■	■	3	1080p/60	B	---
■	■	■	■	■	■	■	■	■	■	4	720p/50	C	---
■	■	■	■	■	■	■	■	■	■	5	1080i/50	D	---
IR 1 ON	IR 2 ON	IR 3 ON	IR OUT ON	38400 bps	---	---	---	ON	---	6	1080p/50	E	1080p/30
1	2	3	4	5	6	7	8	9	10	7	480i/29.97 (YPbPr)	F	1080p/25

The Quick-Connect Interfaces and Basic Configurations

- HD-18 Quick-Connect SR Interface (used with REVEAL Systems 999-6925-000, 999-6925-001, 999-6935-000 and 999-6935-001):

Rear Panel of the HD-18 Quick-Connect SR Interface (1/3 Rack Width Enclosure)

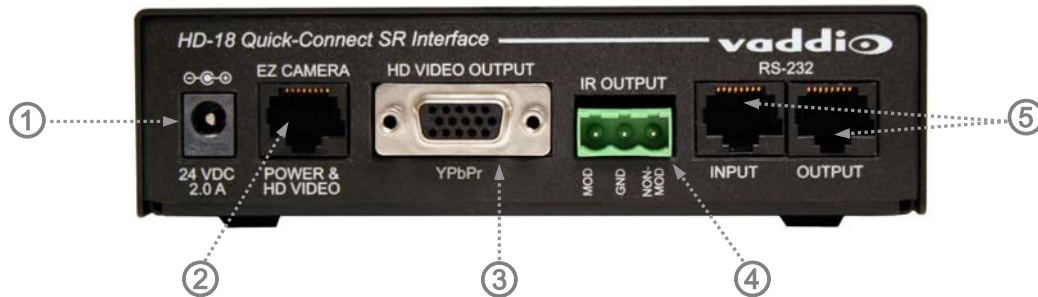

Connectors:

- 1) **Power Input:** 24 VDC, 2.0 Amp Power Connection, 5.5mm OD x 2.5mm ID, Positive Center.
- 2) **EZCamera POWER & HD VIDEO:** The Cat. 5e connection supplies 24 VDC power to the REVEAL and returns HSDS differential video from the camera. Maximum distance on the CAT-5 cable is 100 feet (30.5 m)
- 3) **HD VIDEO OUTPUT:** DE-15F (15-pinHD) connector outputs the YPbPr analog component video from the REVEAL camera. Note: The REVEAL also puts out SD video (480i/30fps & 576i/25fps) in YPbPr analog component format.
- 4) **IR OUTPUT Ports:** With the IR pass-thru function (IR OUT) turned on at the camera (see Camera Switch Settings section), it is possible to send IR from third-party IR remote controls to third-party equipment, such as videoconferencing codecs. IR can be output as either modulated (for IR Probe) or non-modulated (direct connection) signals for added flexibility in codec connection.
- 5) **RS-232 Input & Output RJ-45 Jacks:** The RS-232 INPUT RJ-45 accepts signals from controllers and the RS-232 OUTPUT is connected to the camera, although this port can be bypassed when not using 3rd party IR remotes. When using the IR pass-thru function, the IR signals are pulled from the REVEAL from the RS-232 Output Cat. 5e cable.

System Connectivity Example: Featuring the REVEAL Camera, HD-18 Quick-Connect SR Interface & Precision Camera Controller.

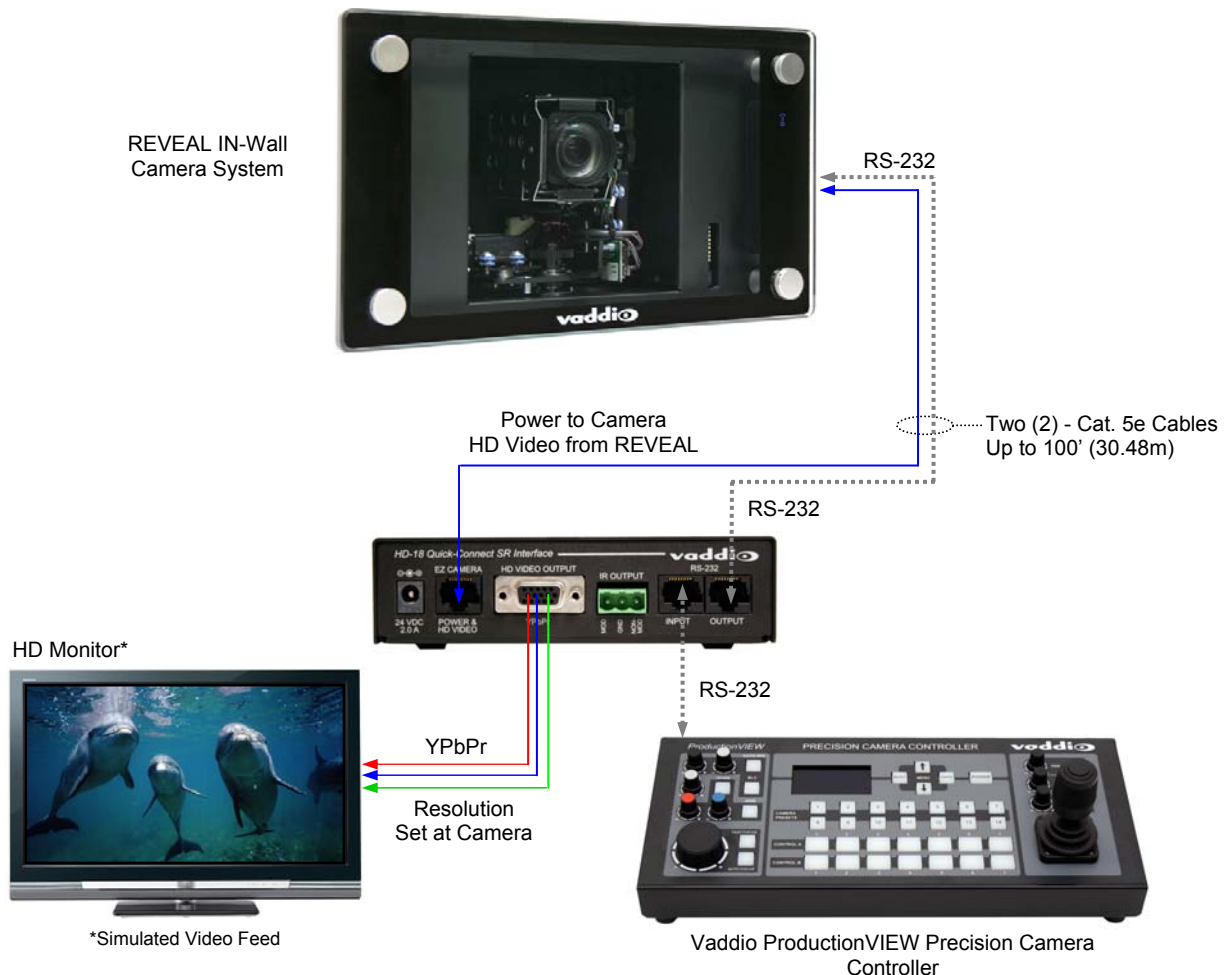

- Quick-Connect DVI/HDMI - SR Interface (used with REVEAL SYSTEMS 999-6926-000, 999-6926-001, 999-6936-000 and 999-6936-001):

Rear Panel of the Quick-Connect DVI/HDMI - SR Interface (1/2 Rack Width Enclosure)

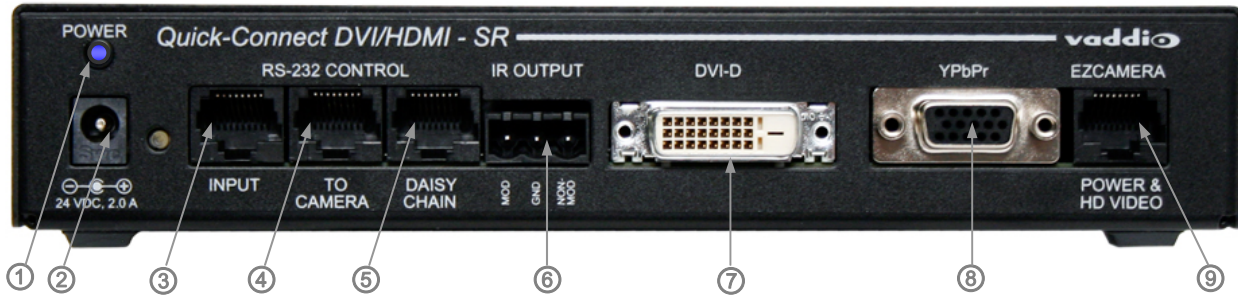

Connectors:

- 1) **Vaddio Blue LED Power Indicator:** Illuminates when the 24 VDC Power supply is plugged in.
- 2) **Power Input:** 24 VDC, 2.0 Amp Power Connection, 5.5mm OD x 2.5mm ID, Positive Center.
- 3) **RS-232 INPUT:** Connect to joystick controller, codec or control system to control the REVEAL Camera.
- 4) **TO CAMERA:** RS-232 Control to & from the Camera and IR signals returned from the camera.
- 5) **DAISY CHAIN Control Port:** Daisy Chain Control Emulation (DCCE) output to next Quick-Connect DVI/HDMI for use when daisy chain control lines can't be avoided.
- 6) **IR OUTPUT Ports:** With the IR pass-thru function (IR OUT) turned on at the camera (see Camera Switch Settings section), it is possible to send IR from third-party IR remote controls to third-party equipment, such as videoconferencing codecs. IR can be output as either modulated (for IR Probe) or non-modulated (direct connection) signals for added flexibility in codec connection.
- 7) **DVI-D Output:** High Definition Multimedia Interface (HDMI) Transmitter, HDMI (v 1.3 with deep color) and DVI v 1.0 Compliant, Resolutions up to 1080p/60 are supported.
- 8) **YPbPr Output:** DE-15F (15-pinHD) connector outputs the YPbPr analog component video from the REVEAL camera. Note: The REVEAL also puts out SD video (480i/30fps & 576i/25fps) in YPbPr analog format. Resolutions up to 1080p/60 with monitor support are possible.
- 9) **EZCamera POWER & HD VIDEO Port:** Supplies power to camera and returns HD video from the camera via Cat-5e. Maximum distance on the CAT-5e cable is 100' (30.5 m).

System Connectivity Example 1: Featuring the REVEAL Camera, Quick-Connect DVI/HDMI SR Interface, Preview Monitors and Precision Camera Controller.

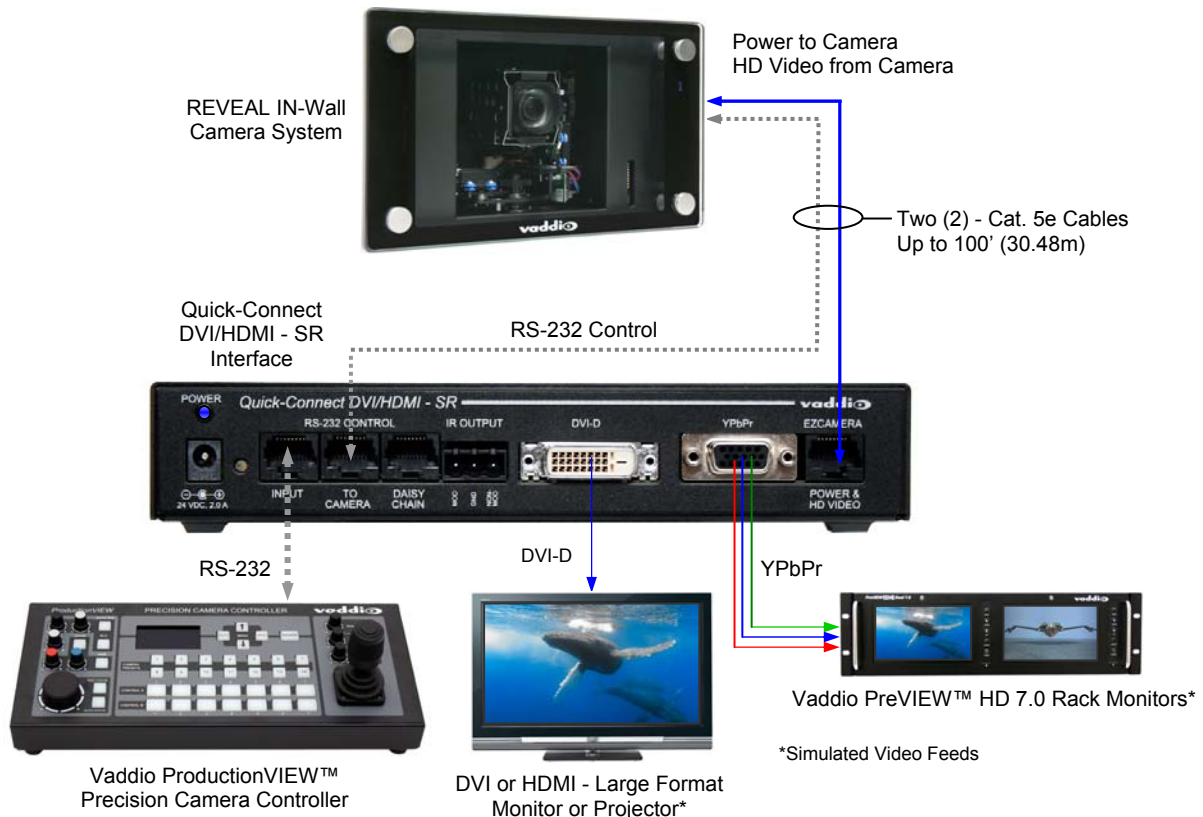

System Connectivity Example 2:

Advanced videoconferencing solution featuring two (2) Vaddio REVEAL cameras, Quick-Connect DVI/HDMI - SR Interfaces, configured with single control port codec (C60) with Daisy Chain Control Emulation (DCCE) and IR forwarded through the main REVEAL camera to the codec via IR emitter.

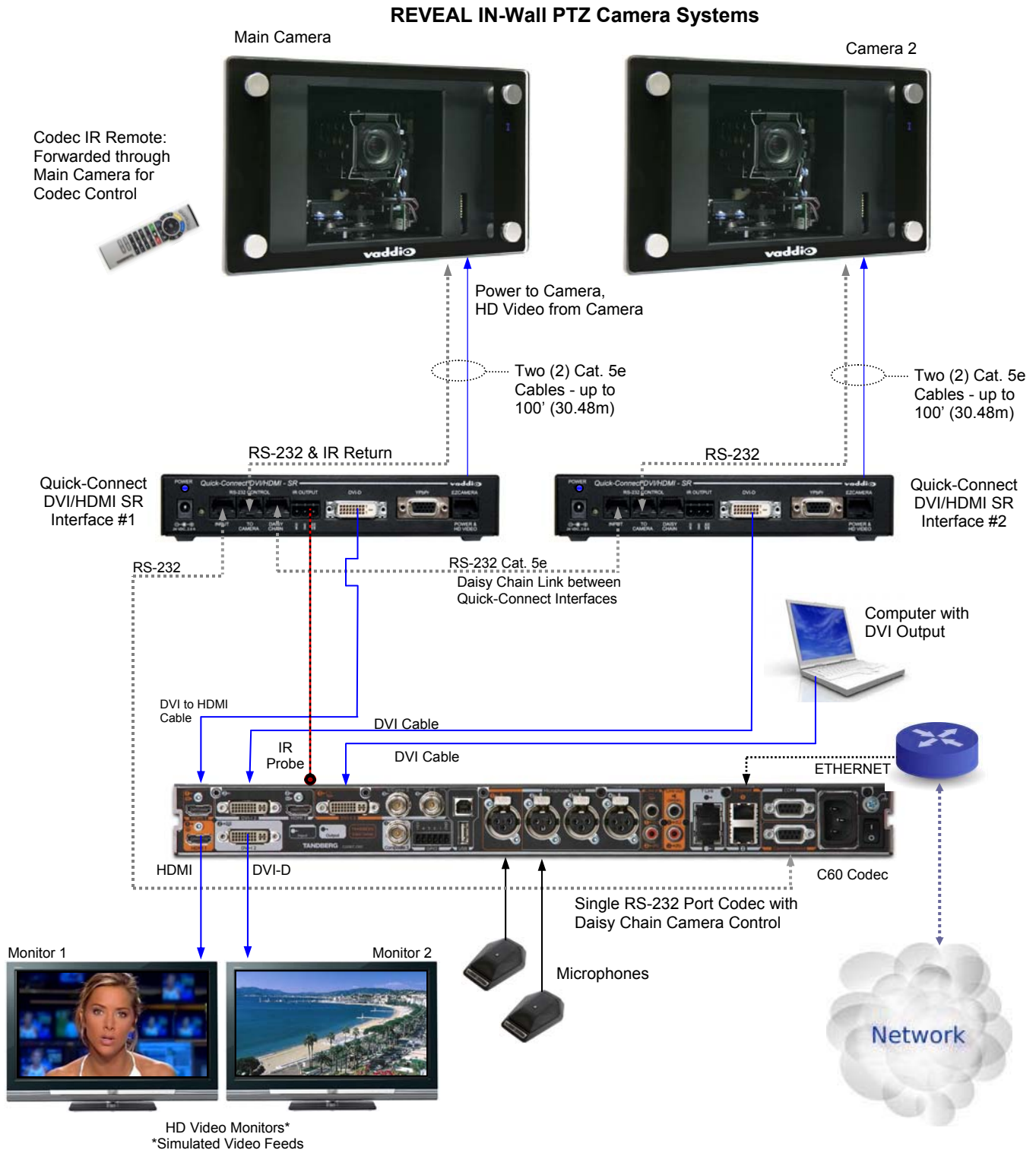

Optional Quick-Connect CCU Controller:

The Quick-Connect CCU controller can be used with any of the REVEAL packages. To review, this CCU Controller differs from the original Quick-Connect CCU in that it does not provide power to the REVEAL camera, nor does it have the HSDS™ differential video I/O. The power and video are handled by the HD-18 Quick-Connect - SR Interface or the Quick-Connect DVI/HDMI - SR Interface. The following section will outline the functions of the front panel controls and the rear panel connectivity.



Front Panel Controls (left to right):

Tally Light:

The blue LED tally light on the front panel is tied to the tally contacts on the rear panel allowing the user to easily track which camera interface is being used in a multi-camera system by supplying a simple contact closure (i.e. from ProductionVIEW Precision Camera Controller or ProductionVIEW HD).

LCD Display:

Backlit (blue) display indicates which parameter (iris, detail, etc.) is being adjusted. When a rotary encoder is moved, the name of the control being adjusted and the value of that assigned parameter will be displayed.

Scenes A, B & C:

Three camera adjustment scenes (A, B & C) can be stored into microprocessor memory. When lit (backlit blue SPDT Button), the scene is activated. To store a scene, the user adjusts the controls and touches and holds the scene button down until the button blinks.

Detail:

The Detail control sharpens or softens objects in the frame.

Red & Blue Gain Controls:

The Red and Blue Gain encoders adjust the red and blue gain of the signal when AWB is disengaged.

AWB:

The Automatic White Balance controls/adjusts the color levels automatically when engaged. Turn off AWB to manually adjust the Red and Blue levels, as well as Red, Green and Blue Enhance.

SHIFT:

Pressing Shift illuminates the button and changes the Pedestal adjustment knob to Knee adjustment. Knee adjustment allows bright objects that are easily overexposed to be reproduced more accurately. Pressing the Shift button a second time turns the light off, and the knob reverts to Pedestal adjustment.

Pedestal / Knee, Chroma & Gamma:

The Pedestal adjustment controls the absolute black level of an image. Chroma controls the overall color of the image being captured. Gamma adjusts the overall brightness of an image. See SHIFT for information on Knee.

Auto Iris:

The Auto Iris mode automatically adjusts the iris and gain of the camera. To manually adjust the iris or gain, turn off this control.

Manual Iris:

The manual iris control allows the user to set the iris manual to one of the 18 settings available.

Gain:

The Gain control boosts the signal level when the iris is open all the way, and there is not enough lighting available. To manually adjust the gain Auto Iris must be off.

Rear Panel Connectivity (left to right):



Power Input:

5.5mm OD x 2.5mm ID, Positive Center 12 VDC, 1.0 Amp, Power Jack
Use with Provided 12 VDC, 1.0 Amp Power supply only.

RS-232 IN:

Control input from Joystick Controller (i.e. Precision Camera Controller, ProductionVIEW HD, etc...), control system or codec. This input provides for camera control other than CCU controls.

RS-232 OUT (To Camera):

Attach to REVEAL camera RS-232 Port for CCU Control. The IR OUT, IR Forwarding feature is not processed by the CCU Controller.

Tally Contact:

Local front panel tally - lights up Blue LED on front panel when shorted.

Camera Settings:

10-position dip switch for added functions and future control parameters.

Instructions for using the Quick-Connect CCU Controller with the REVEAL Camera:



- **Power Up Order:** When using the Quick-Connect CCU, power up the REVEAL camera first, then the Quick-Connect CCU. The Quick-Connect CCU and ProductionVIEW Controllers will auto-detect the camera attached, so naturally the REVEAL has to be ON first.
- **Monitor Set Up:** Verify that the video monitor used in conjunction with the Quick-Connect CCU is set up correctly and is delivering accurate color reproduction.
- **Initial CCU Set Up:** Adjust the iris level of the camera so that brighter areas are not washed out. Then adjust the Pedestal level so that the black levels are not too dark, and not too light. When those levels are set, adjust the Red & Blue Gain, Gamma, Detail, Knee and Chroma. NOTE: Gain (next to Iris) should be left at 0 (zero), unless lighting is inadequate, then turn it to a level where the signal brightness is at an appropriate level. Higher Gain levels add additional noise (grain) to the video signal.
- **IR Output Switch 4:** When operating the REVEAL camera connected directly to the Quick-Connect CCU, set the IR Output dip switch on the front of the REVEAL to the OFF position. If it is not turned off, it may interfere with proper operation of the PTZ camera.

See the next page for a system configuration diagram using the SR Series Interfaces with the CCU controller.

System Connectivity Example: Featuring the REVEAL Camera, HD-18 Quick-Connect SR Interface, REVEAL Series Quick-Connect CCU Controller & ProductionVIEW HD

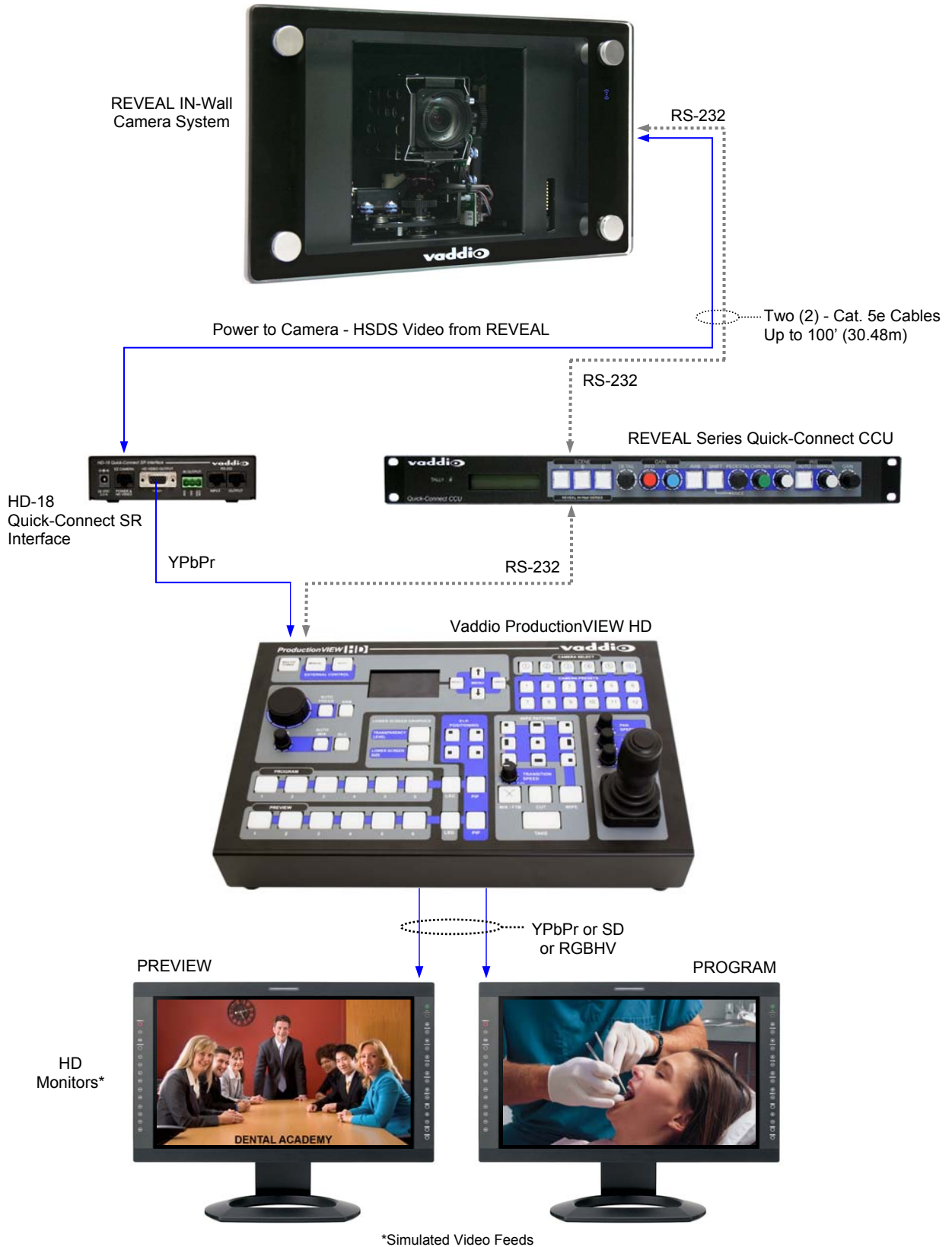

Vaddio IR Remote Commander

The REVEAL camera uses the standard Vaddio IR Remote Commander. Selection of the remote frequency can be performed through a dip switch setting on the REVEAL. The IR remote can transmit up to 3 different sets of IR codes allowing the use and IR control of 3 REVEAL cameras in a room.

The following functions are accessible with the Vaddio remote:

- Camera Power On/Off (Toggle on/off same button)
- Back Light Compensation (Toggle on/off same button)
- Camera Select for Remote: The remote can operate three (3) cameras
- Pan/Tilt and Home controls with Reverse and Std. Pan direction
- Pan/Tilt Reset
- Auto Focus (Toggle on/off same button)
- Data Screen (Toggles the Smart Glass version - frosted to clear)
- Zoom In/Out controls Wide & Telephoto
 - Fast speed controls (W & T)
 - Slow speed controls (W & T)
- Manual Focus On/Off control (Toggle on/off same button)
 - Near (-) adjustment
 - Far (+) adjustment
- Six (6) pan/tilt/zoom positioning presets (1 through 6)
- Preset Set (store)
- Preset Reset (clear)

Vaddio IR Remote Commander

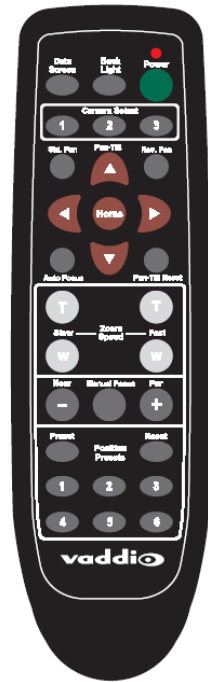

Connectors and Pin-out Detail:

The connections on the top of the camera enclosure are as follows:

- 1) One (1) RJ-45 connector for RS-232 communication and IR Out
- 2) One (1) RJ-45 connector for Power/Video for the Quick-Connect HD-18 - SR or Quick-Connect DVI/HDMI - SR.

RS-232/IR Out RJ-45:

This jack provides for RS-232 bi-directional control and IR Out for IR Forwarding of 3rd party IR Remotes to control codecs.

Pin	Function
1)	Unused
2)	Unused
3)	Unused
4)	IR Output (Diff Signal to Quick-Connect)
5)	IR Ground (Diff Signal to Quick-Connect)
6)	GND
7)	RXD (from TXD of control source)
8)	TXD (to RXD of control source)

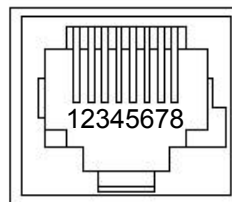

Power/Video RJ-45:

The Power/Video Port supplies power to the REVEAL and returns HSDS (differential HD Video) up to 100' (30.5m).

Pin	Function
1)	Power+
2)	Power-
3)	Y+
4)	PB+
5)	PB GND
6)	Y GND
7)	PR+
8)	PR-

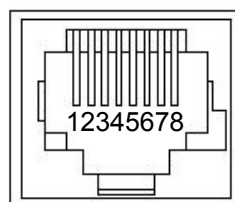

Switch Settings Detail:

There are user accessible rotary and dip switches to select video resolution and other functions as well. The switches are as follows:

- 16-Position Rotary Switch with Detents for HD Video Selection:**
 The REVEAL camera has user selectable video output resolution. The video resolutions are selected via the 16-position rotary switch (right) which is accessible from the front of the REVEAL camera.



Accessible Switch Gear

The video resolution assignments are as follows:

Position	Resolution
0	720p/59.94
1	1080i/59.94
2	1080p/59.94
3	1080p/60
4	720p/50
5	1080i/50
6	1080p/50
7	480i/29.97 (YPbPr - component video)
8	576i/25 (YPbPr - component video)
9	Unused/Future
A	---
B	---
C	---
D	---
E	1080p/30
F	1080p/25



16-Position Rotary Switch

- 10-position Dip Switch**

The REVEAL has a 10-position dip switch accessible on the front of the camera for IR frequency selection, and other control functions. The accessible functions are listed below:

Functions:

Position	Resolution
1	IR Freq 1 - On/Off
2	IR Freq 2 - On/Off
3	IR Freq 3 - On/Off
4	IR Out - On/Off
5	Control Speed - 9600 or 38400
6	Unused
7	Unused
8	Unused
9	Test Bars - On/Off
10	Unused

10-Position Dip Switch

Accessible from the front of the REVEAL camera without the glass in place

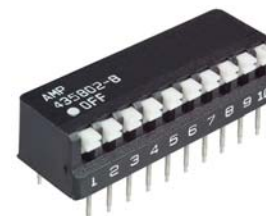

UP - ↑
DOWN - ↓

GENERAL SPECIFICATIONS:

REVEAL IN-Wall Camera Systems	
Part Numbers	999-6925-000 - Clear Glass - HD-18 Quick-Connect SR Interface - North American Version 999-6925-001 - Clear Glass - HD-18 Quick-Connect SR Interface - International Version 999-6926-000 - Clear Glass - Quick-Connect DVI/HDMI SR Interface - North American Version 999-6926-001 - Clear Glass - Quick-Connect DVI/HDMI SR Interface - Euro & UK Cord Set 999-6935-000 - Smart Glass - HD-18 Quick-Connect SR Interface - North American Version 999-6935-001 - Smart Glass - HD-18 Quick-Connect SR Interface - International Version 999-6936-000 - Smart Glass - Quick-Connect DVI/HDMI SR Interface - North American Version 999-6936-001 - Smart Glass - Quick-Connect DVI/HDMI SR Interface - International Version Option 999-1105-022 - Quick-Connect CCU Controller for REVEAL
• Camera Characteristics	
Image Device	1/3-type CCD Sensor
Picture Elements	1.3 Megapixel
Video Resolutions	720p-59.94/50, 1080i-59.94/50, 1080p-60/59.94/50/30/25, 480i/30fps, 576i/25fps
Lens	18x Optical Zoom
Focal Length	f=4.7 to 84.6mm
Horizontal Viewing Angle	3.2 to 55.2 degrees (16:9)
Frame Delay	1 frame
Video S/N Ratio	>50 dB
Invertible	Yes
Minimum Illumination	1.8 Lux
Control Protocol	VISCA
Serial Communication	RS-232 (9600 or 38,400)
Pan Range	140 degrees (\pm 70 degrees)
Tilt Range	+25 degrees to -40 degrees
Preset Positions	16 (internal), 6 recalled via IR Remote
• Quick-Connect Systems (Quick-Connect DVI/HDMI SR Interface and HD-18 Quick-Connect SR Interface)	
YPbPr Support (Analog Component)	HD-18 Quick-Connect SR Interface Power Connector: 5.5mm OD x 2.5mm ID, Positive Center Control In RJ-45: Accepts RS-232 from ProductionVIEW or other non-daisy-chain control systems Control Out RJ-45: To REVEAL Camera Video RJ-45: Transports power to REVEAL and return HSDS video from camera YPbPr Out: DE-15F Connector, Resolution set at camera 1/3-Rack Size - Accessory Rack Panel Option: 998-6000-002
DVI-D/HDMI and YPbPr Support (Digital - DVI-D and HDMI with adapter cable and Analog Component)	Quick-Connect DVI/HDMI SR Interface Power Connector: 5.5mm OD x 2.5mm ID, Positive Center Control In RJ-45: Accepts RS-232 from ProductionVIEW or other non-daisy-chain control systems Control Out RJ-45: To REVEAL Camera Video RJ-45: Transports power to REVEAL and return HSDS video from camera YPbPr Out: DE-15F Connector, Resolution set at camera DVI-D Out: HDMI (v1.3 with deep color) Transmitter and DVI v1.0 Compliant, Resolutions up to 1080p/60 supported DCCE - Daisy Chain Control Emulation Port: RJ-45 Connector 1/2-Rack Size - Accessory Rack Panel Option: 998-6000-003
Cat. 5e Cable Distance	Up to 100' (30.5m) for Video, Power and Control
Power Supply	24 VDC, 2.0 Amp PowerRite Power Supply included with AC Cord Sets
Dimensions	1-RU Rack Mount - 1.72" H x 19" W x 6" D (4.45 cm x 4.26 cm x 15.24 cm)
• REVEAL Module Characteristics	
Glass Properties	The REVEAL Smart Glass is composed of a liquid crystal matrix, laminated between ITO (Indium tin oxide) layers and glass. When a charge is applied to the opaque glass, the glass becomes transparent. The REVEAL Clear Glass model uses clear glass.
Power Consumption	500mA in stand-by frosted opaque mode, 550mA in clear glass camera on mode
Connectors	Two (2) RJ-45 on top of camera enclosure: One (1) for Power and HSDS Video, One (1) for Control
Dimensions (H x W x D)	IN-Wall section of back box: 5.75" (146mm) H x 8.5" (216mm) W x 3.85" (98mm) D, Wall cut out dimensions: 6" (152.4mm) H x 8.75" (222.25) W Outer Frame Size: 6.75" (171.5mm) H x 11.75" (298.5mm) W Glass Dimensions: 7.1875" (182.56mm) H x 12.75" (323.85mm) W x 0.4125" D (Clear Glass, 0.5" D (Smart Glass) Glass Offset from wall: 1.25" (31.75mm)
Weight	8.55 lbs. (3.878214763500001 kg, roughly)
• Optional Quick-Connect CCU Controller for REVEAL Series Cameras	
Connectors	Power Connector: 5.5mm OD x 2.5mm ID, Positive Center Control In RJ-45: Accepts RS-232 from ProductionVIEW or other non-daisy-chain control systems Control Out RJ-45: To REVEAL Camera Tally: 2-Pin Phoenix type connector Video RJ-45: Transports power to REVEAL and return HSDS video from camera
Controls	3-Preset Scenes, Detail, AWB, Red Gain, Blue Gain, Pedestal, Knee, Chroma, Gamma, Iris (Auto/Manual), Gain
Dimensions	1-RU Rack Mount - 1.72" H x 19" W x 6" D (4.45 cm x 4.26 cm x 15.24 cm)

Compliance and CE Declaration of Conformity - REVEAL IN-Wall Camera Systems and HD-18 Quick- Connect SR Interface



FCC Part 15 Compliance

This equipment has been tested and found to comply with the limits for a Class A digital device, pursuant to Part 15 of the FCC Rules. These limits are designed to provide reasonable protection against harmful interference when the equipment is operated in a commercial environment. This equipment generates, uses, and can radiate radio frequency energy and, if not installed and used in accordance with the instruction manual, may cause harmful interference to radio communications. Operation of this equipment in a residential area is likely to cause harmful interference in which case the user will be required to correct the interference at his/her own expense.

Operation is subject to the following two conditions: (1) This device may not cause interference, and (2) This device must accept any interference including interference that may cause undesired operation of the device.

Changes or modifications not expressly approved by Vaddio can affect emission compliance and could void the user's authority to operate this equipment.



ICES-003 Compliance

This digital apparatus does not exceed the Class A limits for radio noise emissions from digital apparatus set out in the Radio Interference Regulations of the Canadian Department of Communications.

Le présent appareil numérique n'émet pas de bruits radioélectriques dépassant les limites applicables aux appareils numériques de la classe A prescrites dans le Règlement sur le brouillage radioélectrique édicté par le ministère des Communications du Canada.



European Compliance

This product has been evaluated for Electromagnetic Compatibility under the EMC Directive for Emissions and Immunity and meets the requirements for a Class A digital device. In a domestic environment this product may cause radio interference in which case the user may be required to take adequate measures.

Standard(s) To Which Conformity Is Declared:

EMC Directive 2004/108/EC

EN 55022 A: 2006 + A1 2007 (CISPR 22:2005/A1:2005) Conducted and Radiated Emissions

EN 55024: 1998 + Amendments A1: 2001 + A2: 2003 - Electromagnetic Compatibility - Immunity

EN 61000-4-2: 1995 + Amendments A1: 2001 + A2: 2003 - Electrostatic Discharge

EN 61000-4-3: 2006 - Radiated Immunity

EN 61000-4-4: 2004 + Corrigendum 2006 - Electrical Fast Transients

EN 61000-4-5: 2006 - Surge Immunity

EN 61000-4-6: 2007 - Conducted Immunity

EN 61000-4-8: 1993 + Amendment A1: 2001 - Power Frequency Magnetic Field

EN 61000-4-11: Second Edition: 2004 - Voltage Dips, Interrupts and Fluctuations

Compliance and CE Declaration of Conformity - Quick-Connect DVI/HDMI SR Interface



FCC Part 15 Compliance

This equipment has been tested and found to comply with the limits for a Class A digital device, pursuant to Part 15, Subpart B, of the FCC Rules. These limits are designed to provide reasonable protection against harmful interference when the equipment is operated in a commercial environment. This equipment generates, uses, and can radiate radio frequency energy and, if not installed and used in accordance with the instruction manual, may cause harmful interference to radio communications. Operation of this equipment in a residential area is likely to cause harmful interference in which case the user will be required to correct the interference at his/her own expense.

Operation is subject to the following two conditions: (1) This device may not cause interference, and (2) This device must accept any interference including interference that may cause undesired operation of the device.

Changes or modifications not expressly approved by Vaddio can affect emission compliance and could void the user's authority to operate this equipment.



ICES-003 Compliance

This digital apparatus does not exceed the Class A limits for radio noise emissions from digital apparatus set out in the Radio Interference Regulations of the Canadian Department of Communications.

Le présent appareil numérique n'émet pas de bruits radioélectriques dépassant les limites applicables aux appareils numériques de la classe A prescrites dans le Règlement sur le brouillage radioélectrique édicté par le ministère des Communications du Canada.



European Compliance

This product has been evaluated for Electromagnetic Compatibility under the EMC Directive for Emissions and Immunity and meets the requirements for a Class A digital device. In a domestic environment this product may cause radio interference in which case the user may be required to take adequate measures.

Standard(s) To Which Conformity Is Declared:

EMC Directive 2004/108/EC

EN 55022 A: 2006 + A1 2007 (CISPR 22:2005/A1:2005) Conducted and Radiated Emissions

EN 55024: 1998 + Amendments A1: 2001 + A2: 2003 - Electromagnetic Compatibility - Immunity

EN 61000-4-2 Electrostatic Discharge

EN 61000-4-3 Radiated Immunity

EN 61000-4-4 Electrical Fast Transients

EN 61000-4-5 Surge Immunity

EN 61000-4-6 Conducted Immunity

EN 61000-4-8 Power Frequency Magnetic Field

EN 61000-4-11 Voltage Dips, Interrupts and Fluctuations

To comply with the EMC Directive, it is recommended that the supplied ferrite cylinders are applied to the cables as described below:

- One (1) Laird Technologies 28A2432-0A2 Clamp-on Ferrite Cylinder (If using the IR Forwarding Function, wrap IR forwarding LED wires twice before screwing stripped wire ends to 3 conductor Molex 5.0mm Euro Jack)
- Two (2) Laird Technologies 28A0640-0A2 Clamp-on Ferrite Cylinder (Clamp around 0.8" diameter shielded DVI cable at the Quick-Connect end)
- One (1) Laird Technologies HFA163090-0A2 Clamp-on Ferrite Cylinder (Clamp around 0.8" diameter shielded DVI Cable at the Monitor end).



Compliance and CE Declaration of Conformity - Quick-Connect CCU Controller for REVEAL Series Cameras



FCC Part 15 Compliance

This equipment has been tested and found to comply with the limits for a Class A digital device, pursuant to Part 15 of the FCC Rules. These limits are designed to provide reasonable protection against harmful interference when the equipment is operated in a commercial environment. This equipment generates, uses, and can radiate radio frequency energy and, if not installed and used in accordance with the instruction manual, may cause harmful interference to radio communications. Operation of this equipment in a residential area is likely to cause harmful interference in which case the user will be required to correct the interference at his/her own expense.

Operation is subject to the following two conditions: (1) This device may not cause interference, and (2) This device must accept any interference including interference that may cause undesired operation of the device.

Changes or modifications not expressly approved by Vaddio can affect emission compliance and could void the user's authority to operate this equipment.



ICES-003 Compliance

This digital apparatus does not exceed the Class A limits for radio noise emissions from digital apparatus set out in the Radio Interference Regulations of the Canadian Department of Communications.

Le présent appareil numérique n'émet pas de bruits radioélectriques dépassant les limites applicables aux appareils numériques de la classe A prescrites dans le Règlement sur le brouillage radioélectrique édicté par le ministère des Communications du Canada.



European Compliance

This product has been evaluated for Electromagnetic Compatibility under the EMC Directive for Emissions and Immunity and meets the requirements for a Class A digital device. In a domestic environment this product may cause radio interference in which case the user may be required to take adequate measures.

Standard(s) To Which Conformity Is Declared:

EMC Directive 89/336/EEC

EN 55022A: September 1998, A1 October 2000 - Conducted and Radiated Emissions

EN 55024: 1998 + Amendment A1: 2001 - Electromagnetic Compatibility - Immunity

EN 61000-4-2	Electrostatic Discharge Requirements
EN 61000-4-3	Radiated Electromagnetic Field Requirement
EN 61000-4-4	Electrical Fast Transients / Burst Requirements
EN 61000-4-5	Surge Requirements
EN 61000-4-6	Conducted Immunity Requirements
EN 61000-4-8	Power Frequency Magnetic Field Requirements
EN 61000-4-11	Voltage Dips, Interrupts and Fluctuations Requirements

Warranty Information:

Hardware* Warranty - One year limited warranty on all parts. Vaddio warrants this product against defects in materials and workmanship for a period of one year from the day of purchase from Vaddio. If Vaddio receives notice of such defects during the warranty period, they will, at their option, repair or replace products that prove to be defective.

Exclusions - The above warranty shall not apply to defects resulting from: improper or inadequate maintenance by the customer, customer applied software or interfacing, unauthorized modifications or misuse, operation outside the normal environmental specifications for the product, use of the incorrect power supply, improper extension of the power supply cable or improper site operation and maintenance.

Vaddio Customer Service – Vaddio will test, repair, or replace the product or products without charge if the unit is under warranty and is found to be defective. If the product is out of warranty, Vaddio will test then repair the product or products. The cost of parts and labor charge will be estimated by a technician and confirmed by the customer prior to repair. All components must be returned for testing as a complete unit. Vaddio will not accept responsibility for shipment after it has left the premises.

Vaddio Technical Support - Vaddio technicians will determine and discuss with the customer the criteria for repair costs and/or replacement. Vaddio Technical Support can be contacted through one of the following resources: e-mail support at support@vaddio.com or online at www.vaddio.com.

Return Material Authorization (RMA) Number - Before returning a product for repair or replacement, request an RMA from Vaddio's technical support. Provide a technician with a return phone number, e-mail address, shipping address, and product serial numbers and describe the reason for repairs or returns as well as the date of purchase and proof of purchase. Include your assigned RMA number in all correspondence with Vaddio. Write your assigned RMA number on the outside of the box when returning the product.

Voided Warranty – The warranty does not apply if the original serial number has been removed or if the product has been disassembled or damaged through misuse, accident, modifications, or unauthorized repair. Cutting the power supply cable on the secondary side (low voltage side) to extend the power to the device (camera or controller) voids the warranty for that device.

Shipping and Handling - Vaddio will not pay for inbound shipping transportation or insurance charges or accept any responsibility for laws and ordinances from inbound transit. Vaddio will pay for outbound shipping, transportation, and insurance charges for all items under warranty but will not assume responsibility for loss and/or damage by the outbound freight carrier.

• If the return shipment appears damaged, retain the original boxes and packing material for inspection by the carrier. Contact your carrier immediately.

Products not Under Warranty - Payment arrangements are required before outbound shipment for all out of warranty products.

*Vaddio manufactures its hardware products from parts and components that are new or equivalent to new in accordance with industry standard practices.

Other General Information:

Care and Cleaning

Do not attempt to take this product apart at any time. There are no user-serviceable components inside.

- Do not spill liquids in the REVEAL.
- Keep this device away from food and liquid.
- For smears or smudges on the console, wipe with a clean, soft cloth with a light duty household cleaner, "Windex®" type that leaves no residue.
- Do not use any abrasive chemicals.

Operating and Storage Conditions:

Do not store or operate the REVEAL under the following conditions:

- Temperatures above 40°C (104°F) or temperatures below 0°C (32°F)
- High humidity, condensing or wet environments or In inclement weather
- Dusty environments
- In outer space or in a swimming pool
- Under severe vibration

Communication Specification:

- Communication Speed: 9600 bps (default)
- Start bit: 1
- Stop bit: 1
- Data bits: 8
- Parity: None
- No Flow control

NOTE: The Vaddio REVEAL Control Protocol is similar, but not identical to the Sony® VISCA™ command set in order to be compatible with several popular control devices and codecs. Not all VISCA commands are supported and there are many REVEAL specific commands in the following Command and Inquiry Lists.

HD-18 Command List (1/2)

Command Set	V	Command	Command Packet	Comments
AddressSet	Y	Broadcast	88 30 01 FF	Address Set
IF_Clear	Y	Broadcast	88 01 00 01 FF	I/F Clear
CommandCancel	Y		81 2p FF	p: Socket No(=1 to2)
CAM_Power	Y	On	81 01 04 00 02 FF	Power On/Off
	Y	Off	81 01 04 00 03 FF	
CAM_Zoom	Y	Stop	81 01 04 07 00 FF	p:0(Slow) to 7(Fast) p:0(Slow) to 7(Fast) pqrs: Zoom Position* V:(Speed) 0-7
	Y	Tele(Standard)	81 01 04 07 02 FF	
	Y	Wide(Standard)	81 01 04 07 03 FF	
	Y	Tele(Variable)	81 01 04 07 2p FF	
	Y	Wide(Variable)	81 01 04 07 3p FF	
	Y	Direct	81 01 04 47 0p 0q 0r 0s FF	
	Y	Direct(Variable)	81 01 7E 01 4A 0V 0p 0q 0r 0s FF	
CAM_Focus	Y	Stop	81 01 04 08 00 FF	Supported as 'Standard' Supported as 'Standard'
	Y	Far(Standard)	81 01 04 08 02 FF	
	Y	Near(Standard)	81 01 04 08 03 FF	
	Y	Far(Variable)	81 01 04 08 2p FF	
	Y	Near(Variable)	81 01 04 08 3p FF	
	Y	AutoFocus	81 01 04 38 02 FF	
	Y	ManualFocus	81 01 04 38 03 FF	
	Y	Auto/Manual	81 01 04 38 10 FF	
CAM_WB	Y	Auto	81 01 04 35 00 FF	
	Y	Manual	81 01 04 35 05 FF	
CAM_RGain	Y	Reset	81 01 04 03 00 FF	pqr:000-1ff
	Y	Up	81 01 04 03 02 FF	
	Y	Down	81 01 04 03 03 FF	
	Y	Direct	81 01 04 43 00 0p 0q 0r FF	
CAM_BGain	Y	Reset	8x 01 04 04 00 FF	pqr:000-1ff
	Y	Up	8x 01 04 04 02 FF	
	Y	Down	81 01 04 04 03 FF	
	Y	Direct	81 01 04 44 00 0p 0q 0r FF	
CAM_AE	Y	Full Auto	81 01 04 39 00 FF	Auto Exposure Mode Manual Control Mode Shutter Priority Mode Exposure Priority Mode (default) AGC Priority Mode
	Y	Manual	81 01 04 39 03 FF	
	Y	Shutter Priority	81 01 04 39 0A FF	
	Y	Iris Priority	81 01 04 39 0B FF	
	Y	Bright	81 01 04 39 0D FF	
CAM_Iris	Y	Reset	81 01 04 0B 00 FF	pq(0x00-0x11)
	Y	Up	81 01 04 0B 02 FF	
	Y	Down	81 01 04 0B 03 FF	
	Y	Direct	81 01 04 4B 00 00 0p 0q FF	
CAM_Gain	Y	Reset	81 01 04 0C 00 FF	pq(0x00-0x1E)
	Y	Up	81 01 04 0C 02 FF	
	Y	Down	81 01 04 0C 03 FF	
	Y	Direct	81 01 04 4C 00 00 0p 0q FF	

REVEAL Command List (2/2)

Command Set	V	Command	Command Packet	Comments	
CAM_Backlight	Y	On	81 01 04 33 02 FF		
	Y	Off	81 01 04 33 03 FF		
CAM_Aperture	Y	Reset	81 01 04 02 00 FF		
	Y	Up	81 01 04 02 02 FF		
	Y	Down	81 01 04 02 03 FF		
	Y	Direct	81 01 04 42 00 00 0p 0q FF	pq:(0x00-0x3F)	
CAM_Memory	Y	Reset	81 01 04 3F 00 0p FF	p:Memory No(=0-0xf)	
	Y	Set	81 01 04 3F 01 0p FF		
	Y	Recall	81 01 04 3F 02 0p FF		
CAM_IDWrite	Y		81 01 04 22 0p 0q 0r 0s FF	pqrs:Camera ID(==0000 – FFFF)	
IR_Receive	Y	On	81 01 06 08 02 FF		
	Y	Off	81 01 06 08 03 FF		
	Y	On/Off	81 01 06 08 10 FF		
IR_ReceiveReturn	N+	On	81 01 7D 01 03 00 00 FF		
	N+	Off	81 01 7D 01 13 00 00 FF		
Pan-tiltDrive	Y	Up	81 01 06 01 VV WW 03 01 FF	WW: Pan Speed (0x01-0x18) VV:Tilt Speed(0x01-0x14)	
	Y	Down	81 01 06 01 VV WW 03 02 FF		
	Y	Left	81 01 06 01 VV WW 01 03 FF		
	Y	Right	81 01 06 01 VV WW 02 03 FF		
	Y	UpLeft	81 01 06 01 VV WW 01 01 FF		
	Y	UpRight	81 01 06 01 VV WW 02 01 FF		
	Y	DownLeft	81 01 06 01 VV WW 01 02 FF		
	Y	DownRight	81 01 06 01 VV WW 02 02 FF		
	Y	Stop	81 01 06 01 VV WW 03 03 FF		
	Y	Absolute Position	81 01 06 02 VV WW 0Y 0Y 0Y 0Y 0Z 0Z 0Z 0Z FF 0Y 0Y 0Y 0Y 0Z 0Z 0Z 0Z FF		YYYY: Pan Position* ZZZZ: Tilt Position*
	Y	Home			
	Y	Reset	81 01 06 04 FF 81 01 06 05 FF		
	Tally	Y	On	81 01 7E 01 0A 00 02 FF	
Y		Off	81 01 7E 01 0A 00 03 FF		
Preset Pan Speed	Y	Pan/Tilt Speed	81 01 7E 01 0B WW VV ZZ FF	WW: Pan Speed (0x01-0x18) VV:Tilt Speed(0x01-0x14) ZZ:Zoom Speed(0-7);	
Motor Config	Y	Hard Motor Stops	81 01 7E 01 70 00 00 FF		
	Y	Soft Motor Stops	81 01 7E 01 70 00 01 FF		
BLK.Enhance	Y	Pedestal	81 01 7E 53 00 00 0p 0q FF	pq: Black Level (0x01-0xFD)	
GMA.Enhance	Y	Gamma	81 01 7E 54 00 00 0p 0q FF	pq: Gamma (0x00-0x8F)	
CRM.Enhance	Y	Chroma	81 01 7E 55 00 00 0p 0q FF	pq: Chroma (0x08-0x1F)	
KNE.Enhance	Y	Knee	81 01 7E 55 00 00 0p 0q FF	pq: Knee (0x0-07F)	
CAM_Shutter	Y	Reset	81 01 04 0A 00 FF	(Only supported in Shutter Priority Mode)	
	Y	Up	81 01 04 0A 02 FF		
	Y	Down	81 01 04 0A 03 FF		
	Y	Direct	81 01 04 4A 00 00 0p 0q FF		
CAM_ExpComp	Y	On	81 01 04 3E 02 FF	Auto Exposure Off	
	Y	Off	81 01 04 3E 03 FF		
	Y	Reset	81 01 04 0E 00 FF	Auto Expouse On	
	Y	Up	81 01 04 0E02 FF		
	Y	Down	81 01 04 0E 03 FF		
	Y	Direct	81 01 04 4E 00 00 0p 0q FF		
CAM_ICR Cut Filter	Y	ICR On	81 01 04 01 02 FF	ICR On	
	Y	ICR Off	81 01 04 01 03 FF	ICR Off	
*Smart_Glass_Assign		Smart Glass ON	81 01 08 0A 02 ff	Smart Glass ON (clear)	
		Smart Glass OFF	81 01 08 0A 03 ff	Smart Glass OFF (frosted)	

Additional Information:

Pan Range: +/- 17326 (43AE - BC52)
 Tilt Range: +1500 -19000 (3A98 -B5C8)
 (Actual Pan/Tilt ranges defined in Inquiry list)

*Commands for Smart Glass version only. The Clear Glass version will not respond to these commands.

HD-18 Inquiry List (1/1)

Inquiry Command	V	Command	Command Packet	Comments
CAM_PowerInq	Y	81 09 04 00 FF	y0 50 02 FF y0 50 03 FF	On Off(Standby)
CAM_ZoomPosInq	Y	81 09 04 47 FF	y0 50 0p 0q 0r 0s FF	pqr: Zoom Position
CAM_WBModelInq	Y	81 09 04 35 FF	y0 50 00 FF y0 50 05 FF	Auto Manual
CAM_RGain	Y	81 09 04 43 FF	y0 50 00 0p 0q 0r FF	pqr:000-1ff
CAM_BGain	Y	81 09 04 44 FF	y0 50 00 0p 0q 0r FF	pqr:000-1ff
CAM_AEModelInq	Y	81 09 04 39 FF	y0 50 00 FF y0 50 03 FF	Auto Exposure Mode Manual Control Mode
CAM_Iris	Y	81 09 04 4B FF	y0 50 00 00 0p 0q FF	pp(0x00-0x11)
CAM_Gain	Y	81 09 04 4C FF	y0 50 00 00 0p 0q FF	pp(0x00-0x1E)
CAM_BacklightModelInq	Y	81 09 04 33 FF	y0 50 02 FF y0 50 03 FF	On Off
CAM_ApertureInq	Y	81 09 04 42 FF	y0 50 00 00 0p 0q FF	pp(0x00-0x3F)
CAM_MemoryInq	Y	81 09 04 3F FF	y0 50 0p FF	p:Memory No(=0-0xf)
CAM_IDInq	Y	81 09 04 3F FF	y0 50 0p 0q 0r 0s FF	pqrs:(0000 – FFFF)
CAM_ReceiveInq	Y	81 09 06 08 FF	y0 50 02 FF y0 50 03 FF	On Off
Pan-TiltMaxSpeedInq	Y	81 09 06 11 FF	y0 50 WW VV FF	WW: Pan Speed (0x01-0x18) VV:Tilt Speed(0x01-0x14)
Pan-tiltPositionInq	Y	81 09 06 12 FF	y0 50 0Y 0Y 0Y 0Y 0Z 0Z 0Z 0Z FF	YYYY: Pan (0x0100-0x1800) ZZZZ:Tilt (0x0100-0x1400)
TallyInq	Y Y	81 09 7E 01 0A FF	y0 50 02 FF y0 50 03 FF	On Off
PresetSpeedInq	Y	81 09 7E 01 0B FF	y0 50 WW VV ZZ FF	WW: Pan Speed (0x01-0x18) VV:Tilt Speed(0x01-0x14) ZZ:Zoom Speed(0-7);
Motor Config	Y	81 09 7E 01 70 FF	y0 50 00 FF y0 50 01 FF	Hard Motor Stops Soft Motor Stops
BLK.Enhance	Y	81 01 7E 53 FF	y0 50 00 00 0p 0q FF	pq: Black Level (0x01-0xFD)
GMA.Enhance	Y	81 01 7E 54 FF	y0 50 00 00 0p 0q FF	pq: Gamma (0x00-0x8F)
CRM.Enhance	Y	81 01 7E 55 FF	y0 50 00 00 0p 0q FF	pq: Chroma (0x08-0x1F)
KNE.Enhance	Y	81 01 7E 56 FF	y0 50 00 00 0p 0q FF	pq: Knee (0x0-07F)
CAM_AEModelInq	Y	81 09 04 39 FF	y0 50 00 FF y0 50 03 FF y0 50 0A FF y0 50 0B FF y0 50 0D FF	Auto Exposure Mode Manual Control Mode Shutter Priority Mode Exposure Priority Mode AGC Priority Mode
CAM_ShutterPosInq	Y	81 09 04 4A FF	y0 50 00 00 0p 0q FF	pq: ShutterPosition (Only supported in Shutter Priority Mode)
CAM_ExpCompModelInq	Y	81 09 04 3E FF	y0 50 02 FF y0 50 03 FF	On - AE Mode Off Off – AE Mode On
CAM_ExpCompPosInq	Y	81 09 04 4E FF	y0 50 00 00 0p 0q FF	pq: ExpComp Pos -Iris Position
CAM_ICRModelInq	Y	81 09 04 01 FF	y0 50 02 FF y0 50 03 FF	ICR On ICR Off
**Smart_Glass_Status	Y	81 09 08 0a FF	x0 50 02 ff x0 50 03 ff	Smart Glass On (Clear) Smart Glass OFF (Frosted)

**Inquiry for Smart Glass version only. The Clear Glass version will not respond to these inquiries.



9433 Science Center Drive, Minneapolis, MN 55428
Toll Free: 800-572-2011 ▪ Phone: 763-971-4400 ▪ FAX: 763-971-4464
www.vaddio.com