

# OWNER MANUAL

**TTL31-A**  
**TTL33-A**  
**TTL55-A**

LINE ARRAY MODULES

Rev E





# CONTENTS

## **1. INTRODUCTION**

TRANSDUCERS TECHNOLOGY  
ELECTRONICS  
CABINET AND MECHANICS

## **2. GENERAL SAFETY INSTRUCTION AND WARNINGS**

SAFETY PRECAUTIONS  
GENERAL OPERATING PRECAUTIONS

## **3. POWER REQUIREMENTS AND SET-UP**

VOLTAGE  
CURRENT  
GROUNDING  
AC CABLES DAISY CHAINS  
POWERING FROM THREE PHASE

## **4. THE TTL SYSTEM**

AUDIO CONNECTIONS AND CABLING  
SIGNAL CABLE DAISY CHAINS  
INPUT PANEL LEDS

## **5. RIGGING THE SYSTEM**

GENERAL RIGGING WARNINGS AND SAFETY PRECAUTIONS  
"RCF SHAPE DESIGNER" SOFTWARE AND SAFETY FACTOR  
RIGGING SYSTEM  
FLY-BAR SYSTEM  
RIGGING PROCEDURE  
TTL33-A GROUND STACKING  
RCF TTL33-A KART

## **6. SOUND DESIGN**

HOW LINE ARRAYS WORK  
DISTANCE TO THE FAR FIELD OF A LINE ARRAY  
SYSTEM CONFIGURATION  
ARRAY SYSTEM DESIGN  
RCF SHAPE DESIGNER SOFTWARE  
CLIMATIC EFFECTS  
AMPLIFIER GAIN SETTINGS  
USING SUBWOOFERS

## **7. MAINTENANCE PROCEDURES**

PARTS INSPECTION CHECK LIST

## **8. TECHNICAL SPECIFICATIONS**

# 1. INTRODUCTION

*The TT+ line arrays are the active line array module of RCF TT+ family. The TT+ line arrays are a full range, ultracompact, wide dispersion, line array modules that sets a new standard in the touring and theatre sound reinforcement.*

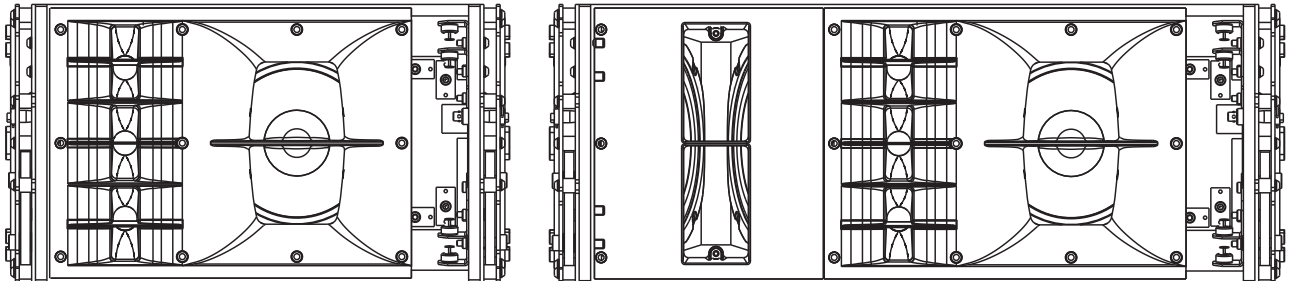

Thanks to digital amplifiers, high power neodymium transducers and well designed cabinet and mechanics the TTL33-A and TTL31-A are unique products and offers the maximum output per size and weight; acoustically are "fully horn loaded" in order to properly control directivity and to provide the highest sensitivity. The system is very easily configurable; the cabinet is 15° shaped and is possible to build very small flown clusters starting from 4 modules or very big, long throw, systems of 16 modules. A 32 bit floating point DSP, sampling at 96 kHz, is taking care of system equalization, 24 db/oct crossovers, soft clipping and system configuration parameters like air absorption or cluster size correction.

## TRANSDUCERS TECHNOLOGY

Each transducer has been specifically designed for the application. The woofer provide large excursion and very light weight, the midrange has an incredibly high BL for best vocal presence, the unique compression driver design offers the minimum spacing between throats to avoid HF cancellation. Thanks to the extensive use of neodymium and new basket designs, the total weight of the transducers is negligible!

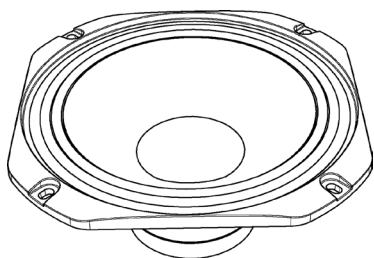

### TTL33-A 8" NEO WOOFERS

The MB8N251 is a high output, high power handling mid-bass designed to provide a very tight and fast response in band-pass designs. Extended response down to 60 Hz, inside-outside voice coil, M-roll surround. The voice coil size is 2.5" .

The TTL33-A is equipped with 2 MB8N251 in bandpass configuration:

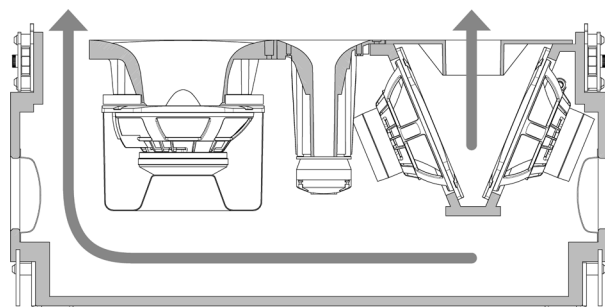

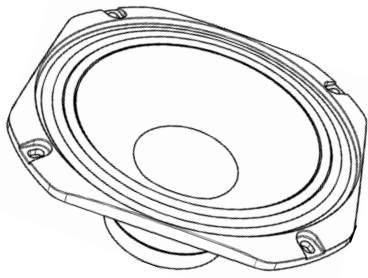

The TTL31-A is equipped with 1 MB8N252 in a hybrid reflex-hornloaded bandpass configuration:

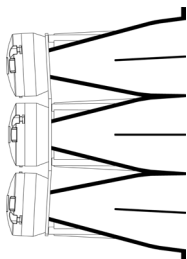
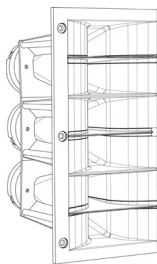
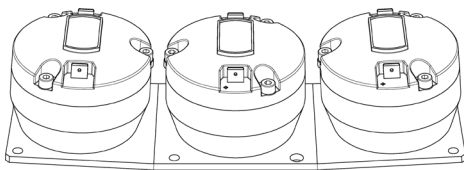
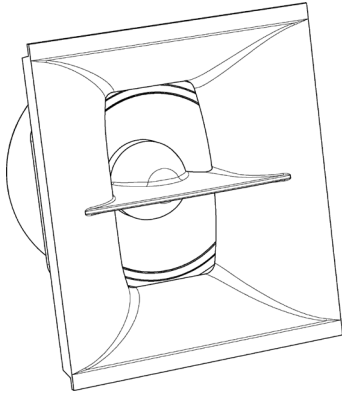

## THE TTL31-A 8" NEO WOOFERS

The MB8N252 is a high output, high power handling mid-bass designed to provide a very tight and fast response in hybrid reflex-hornloading designs. Extended response down to 60 Hz, inside-outside voice coil, M-roll surround. The voice coil size is 2.5".

## THE TTL33-A 8" NEO MIDRANGE

The MR8N251 is a high efficiency, low distortion midrange specially designed to provide superior sound pressure level in a very compact size. The total weight is reduced to less than half of a comparable ceramic midrange thanks to an incredibly powerful neodymium magnet assembly. Every detail of this speaker has been optimised to offer maximum linearity and perfect control to the midrange and midhigh frequencies. The voice coil size is 2.5".

In the TTL33-A application, the MR8N251 is frontally horn loaded and equipped with a lightweight aluminum back-can.

## THE TTL33-A/TTL31-A 1" NEO COMPRESSION DRIVER

The ND1411-MT compression driver is a design conceived for array applications: very high output, high power handling, the overall size is very small for the minimum spacing. Neodymium magnet, titanium dome, mylar surround, radial phase plug. The voice coil size is 36 mm.

The TTL33-A /TTL31-A is equipped with 3 ND1411-MT in horn-loaded configuration.

## HIGH FREQUENCY HORN

The high frequency horn is one of the key parts of the line array. One of the biggest problems in line array designs is the difference in path lengths from driver to driver in high frequencies; this is cause of hf comb filtering and cancellation. To avoid this problem many array designs present in front of the driver complex "acoustic chambers" to equalise different paths ( sound chambers, reflective chambers, waweguides, ...). Those devices are usually creating impulse response problems and acoustic loads that are changing with the frequency.

In the TTL33-A/TTL31-A horn design, thanks to the very small overall diameter of the drivers, the spacing between ND1411-MT centres of emission in the array application is only 70 mm. Thanks to this small spacing it has been possible to equalise the different paths with a simple straight horn, with a very simple design that avoids reflections. The result is a very even frequency response, a coherent wave source, a very natural and transparent sound.

The TTL33-A/TTL31-A high frequency horn is designed to create a continuous and coherent line from cabinet to cabinet.

## TTL55-A LOW SECTION

At low frequency vertical line array pattern control is reached by the constructive interference of the low frequency sources on line array axis and destructive interference on line array off axis. This is true over a frequency range where sources are omni-directional (for a 12inch below 400Hz) and its separation is comparable or lower than signal wave length reproduced (TTL55-A vertical 12inch separation is 380mm this means that we should control vertical pattern with constructive and destructive interference up to 1100Hz). Both these conditions are satisfied in the range where 12inch works.

As the sound wave length decreases, more and more drivers, smaller in size and spaced more closely, are required to maintain directivity. Practical line array systems act as line arrays only in the low and mid frequencies. For the high frequencies, some other method must be founded to reach vertical directional characteristics that match those of the low. The most practical method is to use wave guides coupled to the drivers. Rather than using constructive and destructive interference, the waveguides achieve directionality by confining sound into a specified coverage pattern.

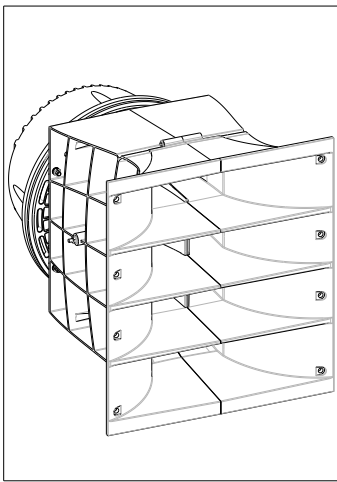

## TTL55-A MID FREQUENCIES

TTL55-A mid frequencies are reproduced by one 10 inch dedicated midrange coupled to dedicated unique 90°H by 15°V wave guide. It has been designed with exponential expansion area for best low frequencies coupling and to minimize distortion and back reflections. Wave guide has been designed to couple a single annular isophase wave front on 10 inch cone to a unique rectangular horn throat capable to create a single isophase rectangular output. This wave guide is then coupled to other horns wave guide to refine the narrow vertical coverage pattern and wide horizontal coverage pattern. Final result show extremely narrow vertical pattern control.

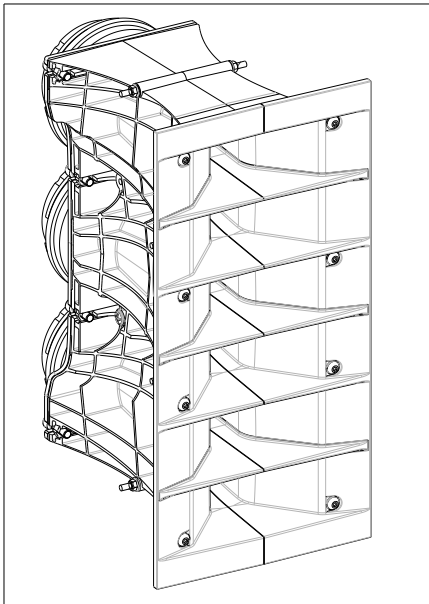

## TTL55 MID-HIGH FREQUENCY WAVE GUIDES

TTL55 is loaded with three 2.5inch voice coil compression driver designed with the minimum overall dimension actually on the pro audio market 4inch (102mm!!). By the driver compact size it has been possible to fit three of them in only 310mm with evident benefit on tight directional vertical control over the frequencies. A dedicated TTL55 high frequency wave guide couples three driver circular (1.3inch diameter) isophase exit to the six rectangular output apertures through six channels with exponential area expansions. Each rectangular channel exit is capable to form a perfect isophase wave front over the frequencies for best coupling to other adjacent exits. From here another horns wave guide with constant directivity is introduced for wide 90° horizontal pattern control. Finally, both mid and high frequency wave guides are closely fitted on TTL55 for better coupling on horizontal plane.

## ELECTRONICS

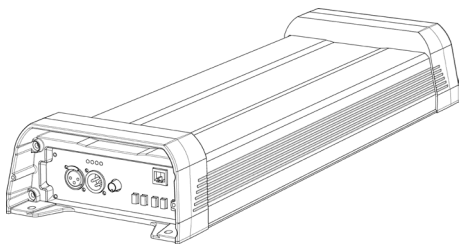

All the TT+ line arrays electronic is in a strong, separate, extruded aluminum housing. From the right side of the amplification module are available Neutrik Powercon input and output, on/off switch and protected ports for the ventilation fan. From the left side of the amplification module are available all the inputs and controls. The amplification module is connected to the main cabinet in 4 points with M6 metric screws and easily removable.

## INPUTS

The TT+ line arrays input section offers XLR input, XLR output for daisy chaining, and sensitivity control (+∞, -2 dB). A set of 5 switch is used for parameters and configuration control: air absorption, cluster size, low frequencies cut off. A data port is available for firmware upgrade and special applications.

## SIGNAL PROCESSING

Each TT+ line arrays cabinet features a last generation, 32 bit floating point DSP for audio processing and a separate micro-processor for general system management.

Analog-digital conversions are operated from high resolution 24 bit, 96 kHz converters.

The signal processing make use of state-of-the-art algorithms and performs a very accurate system equalization (6 point each band), 24 dB/oct crossovers, transducers time alignment, hard limiter circuit, soft clipping circuit.

The DSP reads the system configuration and adjust the parameters to optimise the performances related to air absorption, cluster size and subwoofer filtering. "RCF Shape Designer" software helps defining all parameters for specific projects and system designs.

## AMPLIFIERS

The TT+ line arrays amplification power is delivered from high accuracy, high power digital amplifiers. Very low distortion and very natural sound combined to minimum weight and minimum heat dissipation are the distinctive characteristics of this unique amplifier's design.

### THE TTL55-A AMPLIFICATION SECTION FEATURES:

- 2x1500 watt switching power supply module
- 2x1000 watt low frequency digital amplifier module
- 1000 watt midrange digital amplifier module
- 500 watt high frequency digital amplifier module
- extra capacitor bus able to sustain the full voltage for over 100 ms burst signals

The total available power supply power is 3000 watts and can be distributed to the 4 final amplifier sections. Each amplifier section has a very high maximum output power capability in order to provide, when necessary, maximum output bursts in a specific frequency range. A small fan, speed controlled, guarantee the air circulation inside the amplifier in the most demanding situations.

#### THE TTL33-A AMPLIFICATION SECTION FEATURES:

- 750 watt switching power supply module
- 500 watt low frequency digital amplifier module
- 500 watt midrange digital amplifier module
- 250 watt high frequency digital amplifier module
- extra capacitor bus able to sustain the full voltage for over 100 ms burst signals

The total available power supply power is 750 watts and can be distributed to the 3 final amplifier sections. Each amplifier section has a very high maximum output power capability in order to provide, when necessary, maximum output bursts in a specific frequency range. A small fan, speed controlled, guarantee the air circulation inside the amplifier in the most demanding situations.

#### THE TTL31-A AMPLIFICATION SECTION FEATURES:

- 750 watt switching power supply module
- 500 watt low frequency digital amplifier module
- 250 watt high frequency digital amplifier module
- extra capacitor bus able to sustain the full voltage for over 100 ms burst signals

## **CABINET AND MECHANICS**

The TT+ line arrays cabinet is in baltic birch plywood, coated with high resistance epoxy paint. The wood quality, the small thickness in conjunction to a proper internal bracing, the metal structure design make this cabinet very light and robust.

The mechanical suspension and orientation system is in high quality steel, very precise and easy to use. All the mechanical parts are laser cut, machined and precision assembled with metric screws and threat locker.

The design guarantees a precise inclination of each module from 0° up to 15° in small 2° steps for TTL33-A / TTL31-A and from 0° to 7° in steps of 1° for TTL55-A.

The system is very light and can be moved or transported from one or two people using the side handles or rear handles (on the amplifier sides).

The suspension system is designed to have a proper safety factor (configuration dependent). Using the "RCFShape Designer" software it is very easy to understand safety factors and limits for each specific configuration.

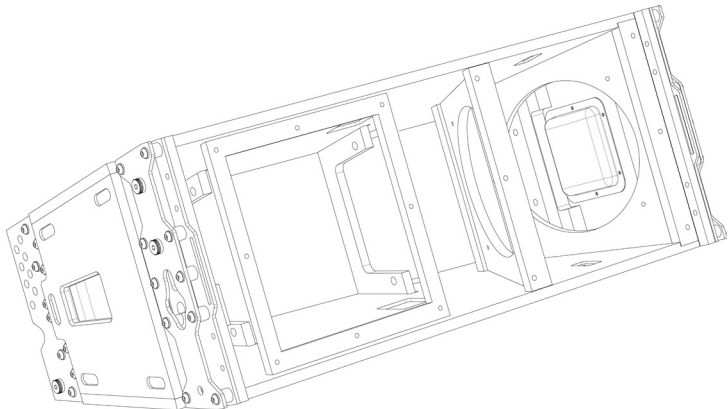



## 2. GENERAL SAFETY INSTRUCTION AND WARNINGS



### IMPORTANT NOTE

*Before connecting using or rigging the system, please read this instruction manual carefully and keep it on hand for future reference. The manual is to be considered an integral part of the product and must accompany the system when it changes ownership as a reference for correct installation and use as well as for the safety precautions. RCF S.p.A. will not assume any responsibility for the incorrect installation and/or use of the product.*



### WARNING

- *To prevent the risk of fire or electric shock, never expose this equipment to rain.*
- *The system TT+ line arrays should be rigged and flown by professional riggers or trained personnel under professional riggers' supervision.*
- *Before rigging the system carefully read this manual.*



## SAFETY PRECAUTIONS

1. All the precautions, in particular the safety ones, must be read with special attention, as they provide important information.
2. The power supply voltage of this equipment is sufficiently high to involve a risk of electrocution; therefore, never install or connect the product with the power supply switched on.
3. Before powering up the amplifier, make sure that all the connections have been made correctly and that the voltage of your power mains corresponds to the voltage shown on the rating plate on the unit; if it does not, please contact your RCF dealer.
4. The metallic parts of the unit are earthed by means of the power cable. In the event that the current outlet used for power does not provide the earth connection, contact a qualified electrician to earth the equipment using the dedicated terminal.
5. To protect the power cable from damage, make sure that it is positioned so that it cannot be stepped on or crushed by objects.
6. To prevent the risk of electric shock, never open the amplifier. There are no parts on the inside that the user needs to access.
7. Make sure that no objects or liquids can get into the amplifier, as this may cause a short circuit.
8. Never attempt to carry out any operations, modifications, or repairs that are not expressly described in this manual. Contact your authorized service centre or qualified personnel should any of the following occur:
  - the amplifier does not function (or functions in an anomalous way);
  - the power supply cable has been damaged;
  - objects or liquids have got into the unit;
  - the amplifier has been subject to heavy impact.
9. When the amplifier is not to be used for long periods of time, switch it off and disconnect the power cable.

10. If the amplifier begins to emit any strange odours or smoke, switch it off immediately and disconnect the power supply cable.
11. Do not connect this product to any equipment or accessories not specified. For suspended installation, only use the dedicated anchoring points and do not try to hang this product using HANDLES or elements that are unsuitable or not specific for this purpose. Also check the suitability of the support surface to which the product is anchored (wall, ceiling, structure, etc.), and the components used for attachment (screw anchors, screws, brackets not supplied by RCF etc.), which must guarantee the security of the system/installation over time, also considering, for example, the mechanical vibrations normally generated by the transducer. To prevent the risk of falling equipment, do not stack multiple units of this product unless this possibility is specified in the instruction manual.
12. RCF Spa. strongly recommends this product is installed by professional qualified installers (or specialised firms) who can ensure correct installation and certify it according to the regulations in force. The entire audio system must comply with the current standards and regulations regarding electrical systems.
13. Supports and trolleys. The equipment should only be used on trolleys or supports, where necessary, that are recommended by the manufacturer. The equipment/support/trolley assembly must be moved with extreme caution. Sudden stops, excessive pushing force and uneven floors may cause the assembly to overturn.
14. Hearing loss. Exposure to high sound levels can cause permanent hearing loss. The acoustic pressure level that leads to hearing loss is different from person to person and depends on the duration of exposure. To prevent potentially dangerous exposure to high levels of acoustic pressure, anyone who is exposed to these levels should use adequate protection devices. When a transducer capable of producing high sound levels is being used, it is therefore necessary to wear ear plugs or protective earphones. See the technical specifications in the instruction manual for the maximum sound pressure the loudspeaker is capable of producing.

#### IMPORTANT NOTE

To prevent the occurrence of noise on the cables that carry microphone signals or line signals (for example, 0 dB), only use screened cables and avoid running them in the vicinity of:

- equipment that produces high-intensity electromagnetic fields (for example, high power transformers);
- mains cables;
- lines that supply loudspeakers.

## GENERAL OPERATING PRECAUTIONS

- Do not obstruct the ventilation grilles of the unit. Situate this product far from any heat sources and always ensure adequate air circulation around the ventilation grilles.
- Do not overload this product for extended periods of time.
- Never force the control elements (keys, knobs, etc. ).
- Do not use solvents, alcohol, benzene or other volatile substances for cleaning the external parts of this product.

### 3. POWER REQUIREMENTS AND SET-UP

#### **⚠ VOLTAGE**

The *TT+ line arrays* amplifier is designed to work within the following AC Voltage limits: 230 Volt NOMINAL VOLTAGE: minimum voltage 185 Volt, maximum voltage 260 Volt 115 Volt NOMINAL VOLTAGE: minimum voltage 185 Volt, maximum voltage 260 Volt . If the voltage goes below the minimum admitted voltage the system stops working If the voltage goes higher than the maximum admitted voltage the system can be seriously damaged. To obtain the best performances from the system it is very important that the voltage drop it is as low as possible.

#### **⚠ WARNING**

- *The TT+ line arrays System is designed to operate in hostile and demanding situations. Nevertheless it is important to take extremely care of the AC power supply and set up a proper power distribution.*
- *The TT+ line arrays System is designed to be GROUDED. Always use a grounded connection.*
- *PowerCon appliance coupler is a AC mains power disconnection device and must be readily accessible during and after the installation.*

#### **CURRENT**

The following are the long term and peak current requirement for each TTL33-A/TTL31-A module:

MODEL	VOLTAGE	BURST (100 ms)	LONG TERM
TTL33-A / TTL31-A	230 Volt	4.5 A	3.15 A
TTL33-A / TTL31-A	115 Volt	9.0 A	6.3 A
TTL55-A	230 Volt	17.7A	6.3A X 2
TTL55-A	115 Volt	28.2A	10A X 2

The total current requirement is obtained multiplying the single current requirement by the number of modules. To obtain the best performances make sure that the total burst current requirement of the system doesn't create a significant voltage drop on the cables.

#### **GROUNDING**

Make sure that all the system is properly grounded. All the grounding points shall be connected to the same ground node. This will improve reducing hums in the audio system.

#### **TTL33-A / TTL31-A, AC CABLES DAISY CHAINS**

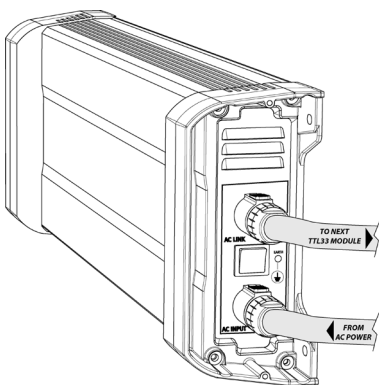

Each TTL33-A/TTL31-A module is provided with a Powercon outlet to daisy chain other modules. The maximum number of modules that is possible to daisy chain is:

**230 VOLT: 6 modules total**

**115 VOLT: 3 modules total**

#### **⚠ WARNING - RISK OF FIRE**

*A superior number of modules in daisy chain will exceed the Powercon connector maximum ratings and create a potentially dangerous situation.*

#### **POWERING FROM THREE PHASE**

When the TT+ line arrays system is powered from a three phase power distribution it is very important to keep a good balance in the load of each phase of the AC power. It is very important to include subwoofers and satellites in power distribution calculation: both subwoofers and satellites shall be distributed between the three phases.

# 4. THE TTL SYSTEM

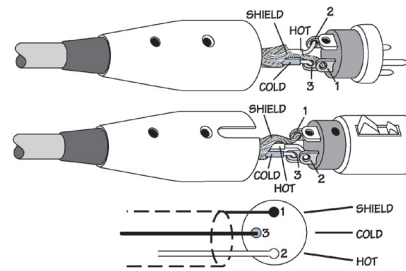

## AUDIO CONNECTIONS AND CABLING

The TT+ line arrays input panel presents balanced XLR input/output.

## SIGNAL CABLES DAISY CHAINS

Audio signal can be daisy-chained using the male XLR loop through connectors. A single audio source can drive multiple speakers modules (like a full left or right channel made of 8-16 speaker modules); make sure that the source device is able to drive the impedance load made of the modules input circuits in parallel.

The TT+ line arrays input circuit presents a 100 KOhm input impedance. The total input impedance seen as a load from the audio source (ex. audio mixer) will be:

- system input impedance =  $100 \text{ KOhm} / \text{number of input circuits in parallel}$ .

The required output impedance of the audio source (ex. audio mixer) will be:

- source output impedance  $> 10 * \text{system input impedance}$
- always make sure that XLR cables used to feed audio signal to the system are:
  - balanced audio cables
  - wired in phase

*A single defective cable can affect the performance of the overall system!*

## TTL55-A INPUT PANEL

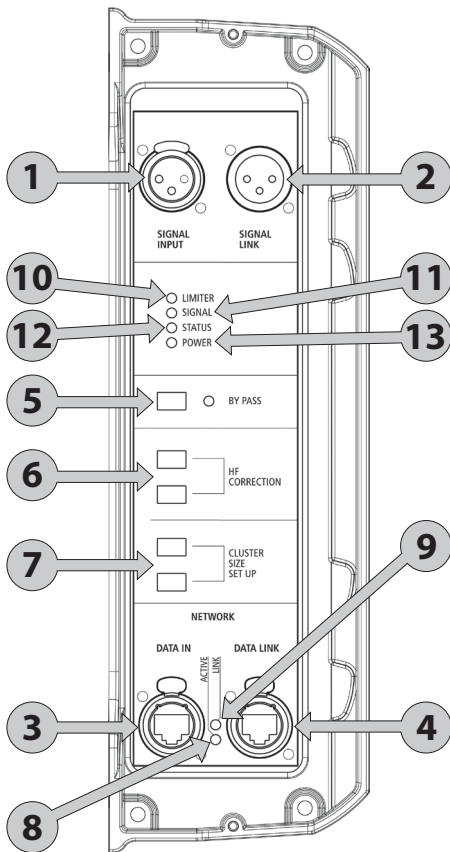

## TTL55-A INPUT PANEL LEDS

The input panel presents 4 system LEDs:

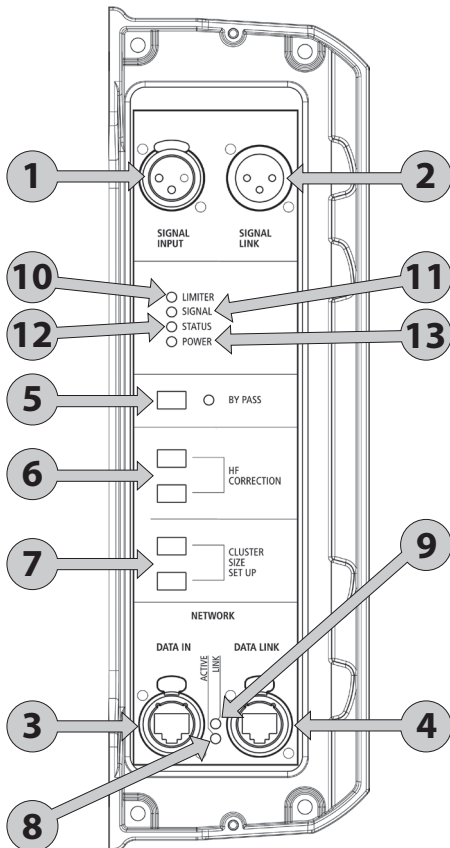

**1 XLR INPUT.**

**2 XLR LINK OUTPUT.**

**3 DATA INPUT.** This port is used for the network input of RD NET remote monitoring

**4 DATA OUTPUT.** This port is used for the network daisy chain output of RD NET remote monitoring.

**5 BY PASS (RESET).** This switch by-pass (reset) the last preset loaded on TTL55A DSP with RD NET remoting control.

**6 HIGH FREQUENCY CORRECTION.** The combination of the 2 top switches gives 4 possibilities of high frequencies correction depending on target distance (air absorption correction):

-near field ( up to 25 meters)

-mid field ( from 25 to 40 meters)

-mid far field ( from 40 to 60 meters)

-far field ( more than 60 meters)

**7 CLUSTER SIZE.** The combination of the 2 central switches gives 4 possibilities of mid low frequencies correction depending on cluster size:

• 4-6 modules (small flown systems)

• 7-9 modules (medium flown systems)

• 10-12 modules (medium large flown systems)

• 13-20 modules (large flown systems)

**8 ACTIVE NETWORK LED.** This led flash when there's a data transmission.

**9 LINK NETWORK LED.** This led is ON when the speaker has been recognized and connected from the RD NET master unit.

**10 RED/ORANGE - LIMITER LED.** This led is ON when the limiter circuit is active to prevent output distortion or damage of the speaker:

- ORANGE - Soft limiter circuit. When the LED is flashing ORANGE one of the power amplifiers reaches the maximum output for short periods of time and the working condition can be considered normal.

- RED - Hard limiter. When the LED is flashing RED (following the signal) one of the power amplifiers reaches the maximum output for longer periods of time. When the LED is blinking RED one of the RMS limiter circuit is active in order to prevent damage to one of the transducers or power amplifiers.

**!** Always avoid operating conditions where the System works for long periods of time with the RED LED flashing or blinking.

**11 GREEN - SIGNAL LED.** This led is ON when the audio input signal is superior to -20 dB. When there is no input signal the led is flashing

**12 YELLOW - STATUS LED.** This LED is flashing during the bootstrap procedure and in case of communication problems with the DSP processor.

**13 GREEN - POWER LED.** This led is ON when the system is connected to the AC power source and the main on/off switch is in position ON.

## TTL33-A/TTL31-A INPUT PANEL

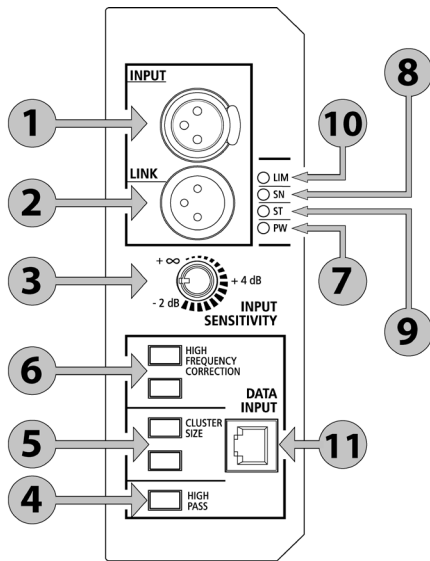

- 1 XLR INPUT.
- 2 XLR LINK OUTPUT.
- 3 SENSITIVITY ( +∞, +4 dB, -2 dB).
- 4 HIGH PASS. This switch inserts a 110 Hz, 24 dB/octave high pass, to be used in conjunction with subwoofers without any high pass signal output. When the system is used in conjunction with the TTS18-A or TTS28-A subwoofers the optimum solution is to use the high pass crossover signal output from the subs and leave the line array module in full range.
- 5 CLUSTER SIZE. The combination of the 2 central switches gives 4 possibilities of mid low frequencies correction depending on cluster size:
  - 2-3 modules (used for stacking configurations)
  - 4-6 modules (small flown systems)
  - 7-9 modules (medium flown systems)
  - 10-16 modules (large flown systems)
- 6 HIGH FREQUENCY CORRECTION. The combination of the 2 top switches gives 3 possibilities of high frequencies correction depending on target distance (air absorption correction):
  - near field ( up to 30 meters)
  - mid field ( from 30 to 60 meters)
  - far field ( more than 60 meters)

## TTL33-A/TTL31-A INPUT PANEL LEDs

The input panel presents 4 system LEDs:

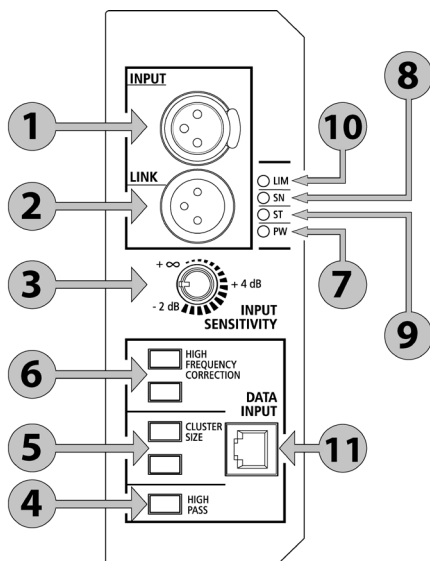

- 7 GREEN - POWER LED. This led is ON when the system is connected to the AC power source and the main on/off switch is in position 1.
- 8 GREEN - SIGNAL LED. This led is ON when the audio input signal is superior to -20 dB. When there is no input signal the led is flashing.
- 9 YELLOW - STATUS LED. This LED is flashing during the bootstrap procedure and in case of communication problems with the DSP processor.
- 10 RED/ORANGE - LIMITER LED. This led is ON when the limiter circuit is active to prevent output distortion or damage of the speaker:
  - ORANGE - Soft limiter circuit. When the LED is flashing ORANGE one of the power amplifiers reaches the maximum output for short periods of time and the working condition can be considered normal.
  - RED - Hard limiter. When the LED is flashing RED (following the signal) one of the power amplifiers reaches the maximum output for longer periods of time. When the LED is blinking RED one of the RMS limiter circuit is active in order to prevent damage to one of the transducers or power amplifiers.



Always avoid operating conditions where the System works for long periods of time with the RED LED flashing or blinking.

- 11 DATA INPUT. This port is used to update DSP firmware, DSP presets, microprocessor firmware.

# 5. RIGGING THE SYSTEM

## GENERAL RIGGING WARNINGS AND SAFETY PRECAUTIONS

- *Suspending loads should be done with extreme caution.*
- *When deploying a system always wear protective helmets and footwear.*
- *Never allow people to pass under the system during the installation process.*
- *Never leave the system unattended during the installation process.*
- *Never install the system over areas of public access.*
- *Never attach other loads to the array system.*
- *Never climb the system during or after the installation.*
- *Never expose the system to extra loads created from the wind or snow.*

## WARNING

- The system must be rigged in accordance with the laws and regulations of the Country where the system is used. It is responsibility of the owner or rigger to make sure that the system is properly rigged in accordance with Country and local laws and regulations.
- Always check that all the parts of the rigging system that are not provided from RCF are:
  - appropriate for the application
  - approved, certified and marked
  - properly rated
  - in perfect condition
- Each cabinet support the full load of the part of the system below. It is very important that each single cabinet of the system is properly checked.

## “RCF SHAPE DESIGNER” SOFTWARE AND SAFETY FACTOR

The suspension system is designed to have a proper **safety factor** (configuration dependent). Using the “RCF Shape Designer” software it is very easy to understand safety factors and limits for each specific configuration. To better comprehend in which safety range the mechanics are working a simple introduction is needed: TT+ line arrays mechanics are built with certified **UNI EN 10025-95 S 235 JR** Steel. RCF prediction software calculates forces on every single stressed part of the assembly and shows the minimum safety factor for every link. S 235 JR is a structural steel and has a stress-strain (or equivalent Force-Deformation) curve like the following:

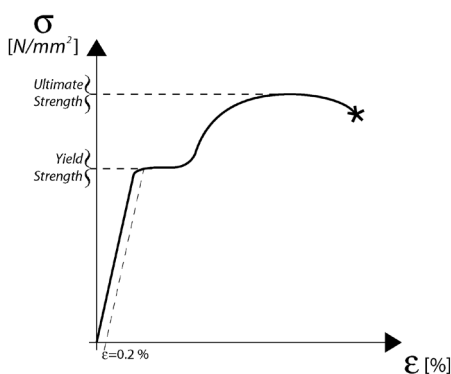

The curve is characterized by two critical points: the **Break Point** and the **Yield Point**. The tensile ultimate stress is simply the maximum stress attained. Ultimate tensile stress is commonly used as a criterion of the strength of the material for structural design, but it should be recognized that other strength properties may often be more important. One of these is for sure the Yield Strength. Stress-strain diagram of S 235 JR exhibit a sharp break at a stress below the ultimate strength. At this critical stress, the material elongates considerably with no apparent change in stress. The stress at which this occurs is referred to as the yield point. Permanent deformation may be detrimental, and the industry adopted 0.2% plastic strain as an arbitrary limit that is considered acceptable by all regulatory agencies. For tension and compression, the corresponding stress at this offset strain is defined as the yield.

S 235 JR characteristic values are  $R=360$  [N/mm<sup>2</sup>] for Ultimate Strength and  $R_{p0.2}=235$  [N/mm<sup>2</sup>] for **Yield Strength**.

In our prediction software the **Safety Factors** are calculated considering the **Maximum Stress Limit** equal to the **Yield Strength**, according with many international standards and rules.

The resulting Safety Factor is the minimum of all the calculated safety factors, for each link or pin.

This is where you are working with a **SF=7**

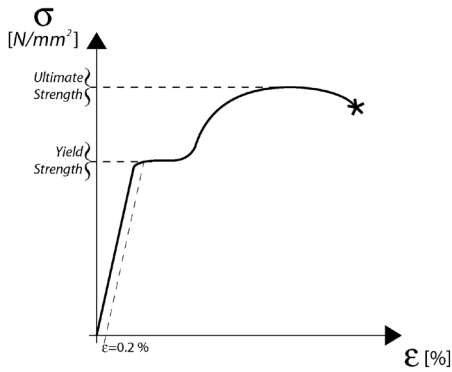

Depending on local safety regulation and on situation the required safety factor can vary. It is responsibility of the owner or rigger to make sure that the system is properly rigged in accordance with Country and local laws and regulations.

The "RCF Shape Designer" software gives detailed information of the safety factor for each specific configuration.

The results are classified in 4 classes:

<b>-GREEN:</b>		<b>SAFETY FACTOR</b>	<b>&gt; 7</b>	<b>SUGGESTED</b>
<b>-YELLOW</b>	<b>4 &gt;</b>	<b>SAFETY FACTOR</b>	<b>&gt; 7</b>	
<b>-ORANGE</b>	<b>1.5 &gt;</b>	<b>SAFETY FACTOR</b>	<b>&gt; 4</b>	
<b>-RED</b>		<b>SAFETY FACTOR</b>	<b>&lt; 1.5</b>	<b>NEVER ADMITTED</b>



### WARNING

- The safety factor is the result of the forces acting on fly bar's and system's front and rear links and pins and depends on many variables:
  - number of cabinets
  - fly bar angles
  - angles from cabinets to cabinets. If one of the cited variables change the safety factor **MUST BE** recalculated using the software before rigging the system.
- In case the fly bar is picked up from 2 motors make sure that the fly bar angle is correct. An angle different from the angle used in the prediction software can be potentially dangerous. Never allow persons to stay or pass under the system during the installation process.
- When the fly bar is **particularly tilted** or the array is **very curved** the centre of gravity can move out from the rear links. In this case the front links are in compression and the rear links are supporting the total weight of the system plus the front compression. Always check very carefully with the "RCF Shape Designer" software all this kind of situations (even with a small number of cabinets).

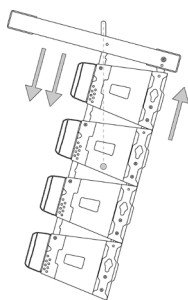

System particularly tilted

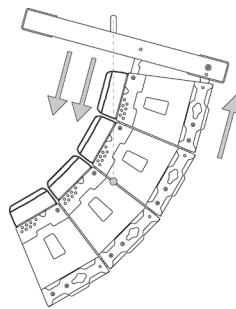

System very curved



## RIGGING SYSTEM

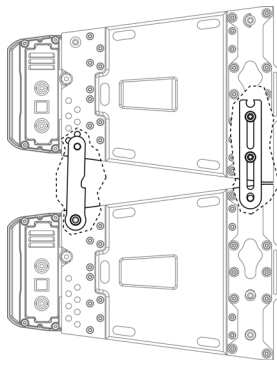

The TT+ line arrays module is provided with 4 rigging bars, 2 in the front and 2 in the rear corners. The rigging bars are securely connected to front and rear metal corners. Front and rear metal corners are securely connected to the cabinet. The rigging system is made of rigging bars and metal corners in sequence. Rigging bars and metal corners are securely connected by:

- Rectified bolts
- Quick lock pins

The wooden cabinet is not a primary part of the rigging system.

## THE TTL55-A FLY BAR

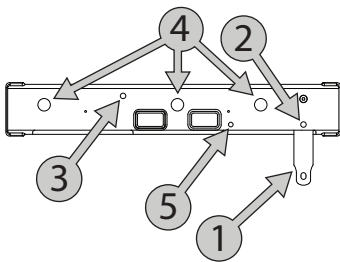

### THE TTL55-A FLY BAR FEATURES:

- 1 FRONT FLYING BRACKET
- 2 QUICK LOCK PIN HOLE (to be used to lock the front bracket before installation)
- 3 REAR BAR HOLE
- 4 SAFETY CHAIN SHACKLE HOLES
- 5 QUICK LOCK PIN HOLE
- 6 PICKUP FIXING HOLES

The TTL55-A system must be suspended using the RCF TTL55-A fly bar

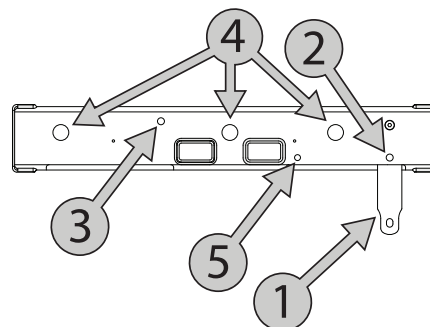
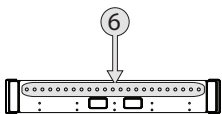

## FRONT BRACKETS, FRONT AND REAR MOUNTING:

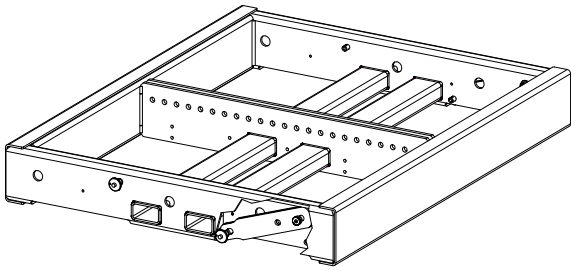

**1** Front brackets in transport position

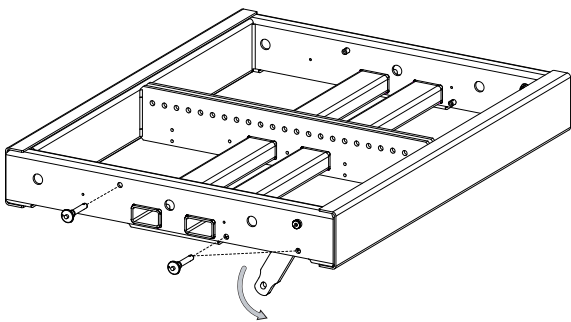

**2** Remove the side pins and tilt the front bracket

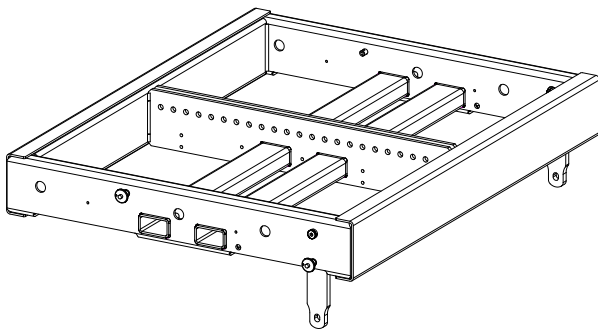

**3** Fix the front brackets in vertical position locking the pin in position 2

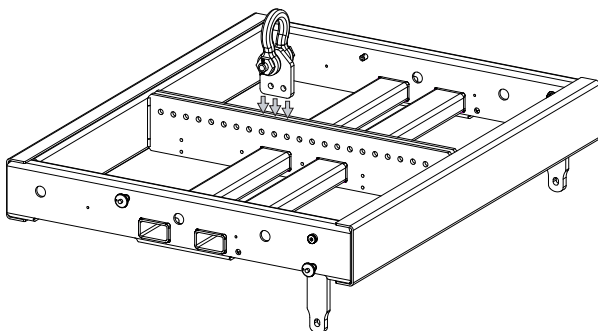

**4** Fit the picip in the middle of the two central brackets

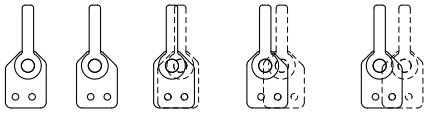

**5** The pickup is asymmetric and can be fit in two positions (A and B). A position brings the shackle towards the front. B position allows an intermediate step using the same fixing holes

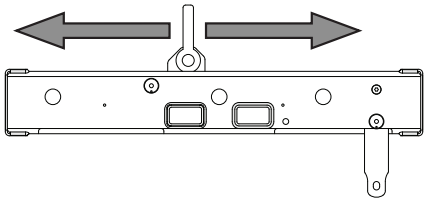

**6** Move the pickup bracket in the position suggested by RCF Shape Designer

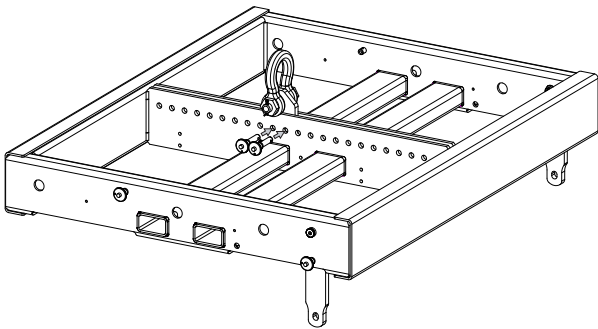

**7** Fix the pickup bracket with the two pins on the bracket's lanyard to lock the pickup

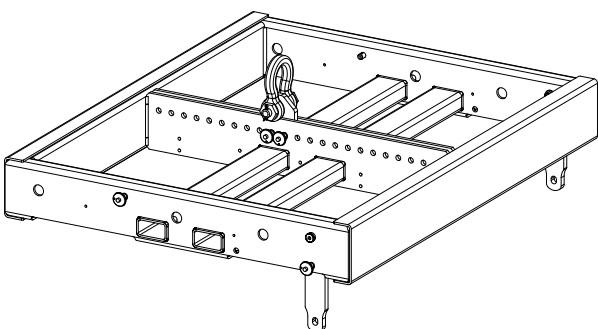

**8** Check that all the pins are secured and locked

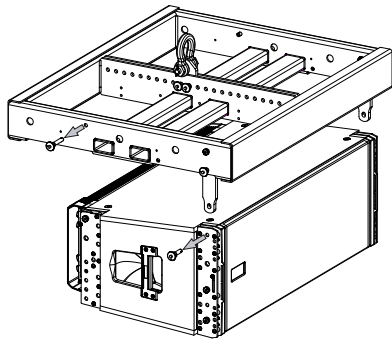

**9** Put the first speaker under the flybar

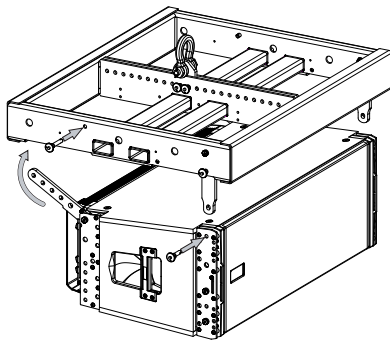

**10** Fit the front flybar brackets in the speaker's front housing and fix it with the quicklock pin supplied with the speaker

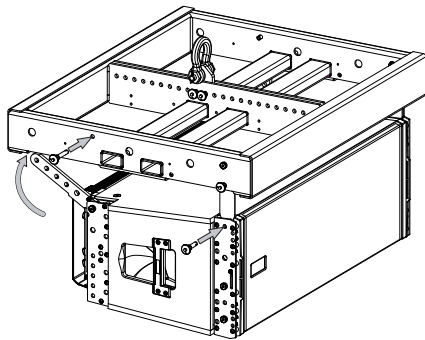

**11** Tilt the speaker's rear bracket in the flybar housing and fix it with the quick lock pin supplied with the flybar

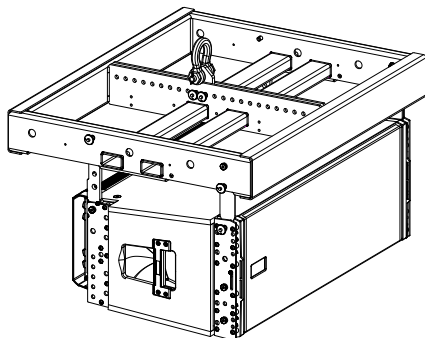

**12** Check that the front and rear pins are secured and locked

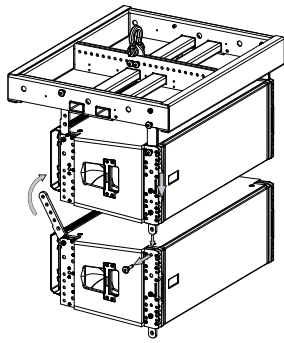

**13** Go on linking the other speakers. Fit the front bracket and fix it tilt the rear bracket, close tilt angle and fix it

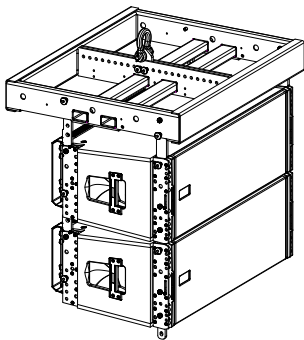

**14** Always check that the pins is locked in the hole corresponding to the tilt angle shown on the bracket

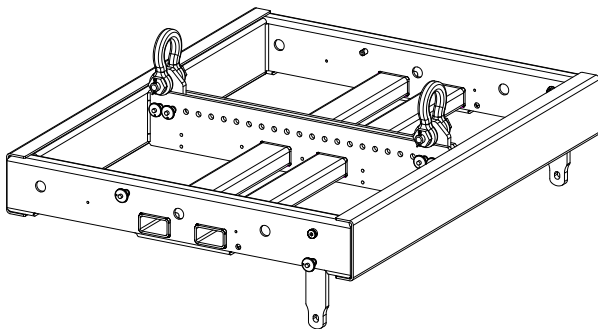

**15** Lifting with two chain hoists allowed adding an optional pickup point

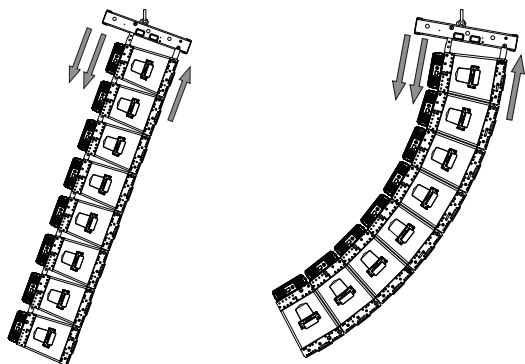

**16** Always check carefully load conditions with RCF Shape Designer

# THE TTL33-A FLY BAR

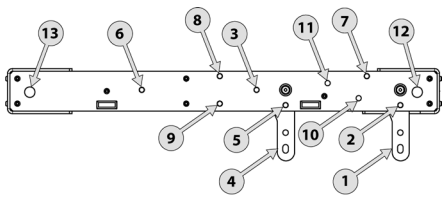

## THE TTL33-A FLY BAR FEATURES:

- 1 FRONT FLYING BRACKET - Front mounting
- 2 QUICK LOCK PIN HOLE - Front mounting (to be used to lock the front bracket before installation)
- 3 REAR BAR HOLE - Front mounting
- 4 FRONT FLYING BRACKET - Rear mounting
- 5 QUICK LOCK PIN HOLE - Rear mounting (to be used to lock the front bracket before installation)
- 6 REAR BAR HOLE - REAR MOUNTING.
- 7 FRONT STACKING POINT.
- 8 REAR STACKING POINT - UPPER POSITION.
- 9 REAR STACKING POINT - LOWER POSITION.
- 10 FRONT BRACKET - TRANSPORT POSITION HOLE.
- 11 REAR BRACKET - TRANSPORT POSITION HOLE.
- 12 CORNER DOUBLE-MOTOR PICK-UP POINT.
- 13 CORNER DOUBLE-MOTOR PICK-UP POINT.
- 14 12 CENTRAL PICK-UP POINTS.

The TTL33-A system must be suspended using the RCF TTL33-A fly bar

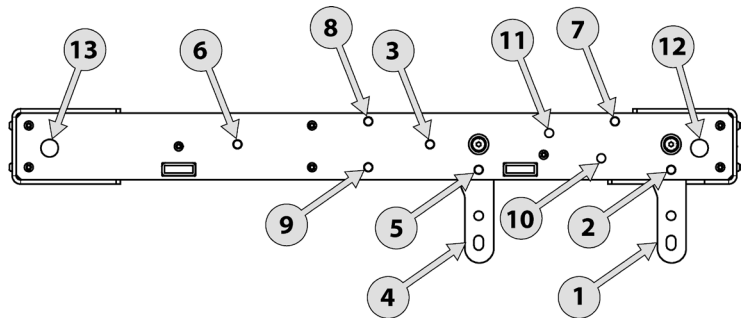
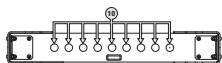

# THE TTL31-A FLY BAR

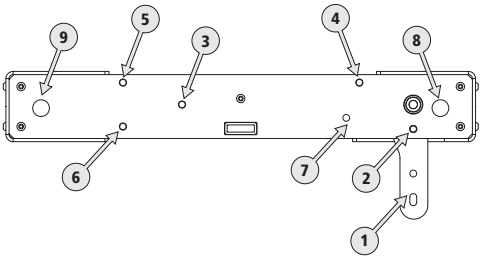

## THE TTL31-A FLY BAR FEATURES:

- 1 FRONT FLYING BRACKET - Front mounting
- 2 QUICK LOCK PIN HOLE - Front mounting (to be used to lock the front bracket before installation)
- 3 REAR BAR HOLE - Front mounting
- 4 FRONT STACKING POINT.
- 5 REAR STACKING POINT - UPPER POSITION.
- 6 REAR STACKING POINT - LOWER POSITION.
- 7 FRONT BRACKET - TRANSPORT POSITION HOLE.
- 8 CORNER DOUBLE-MOTOR PICK-UP POINT.
- 9 CORNER DOUBLE-MOTOR PICK-UP POINT.
- 10 9 CENTRAL PICK-UP POINTS.

The TTL31-A system must be suspended using the RCF TTL31-A fly bar

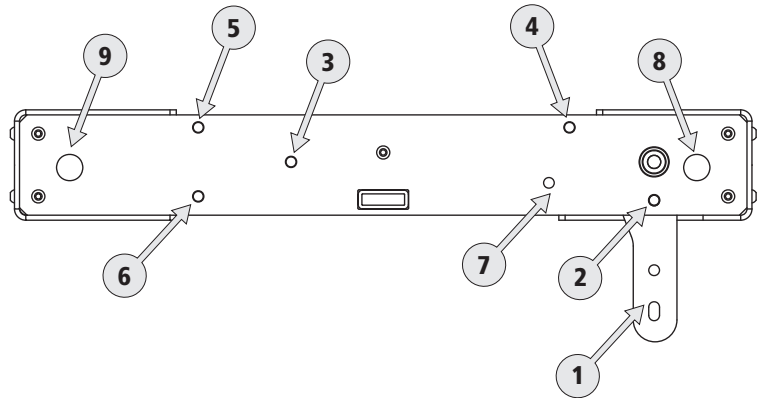
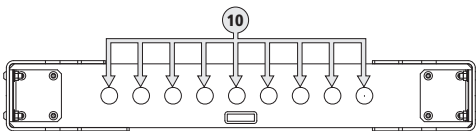

## FRONT BRACKETS, FRONT AND REAR MOUNTING:

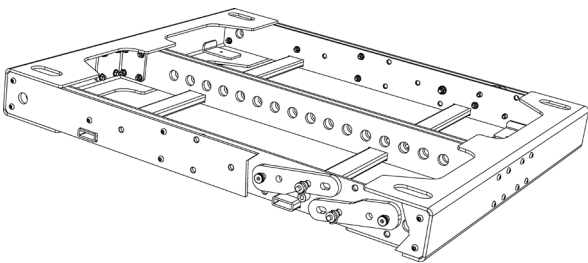

Front brackets in transport position

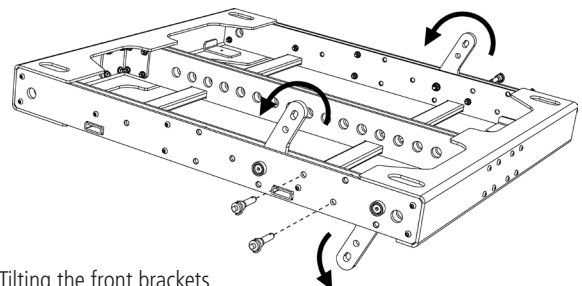

Tilting the front brackets

THE 3 POSSIBLE PICK-UP SYSTEMS FOR THE TTL33-A/TTL31-A FLY BAR ARE THE FOLLOWING:

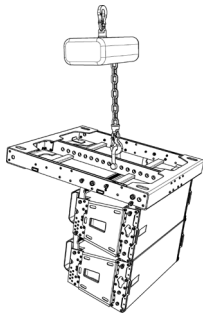

SINGLE MOTOR - CENTRAL PICK-UP

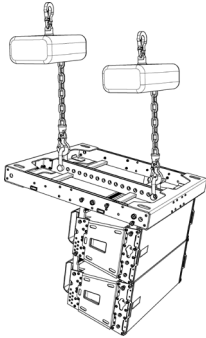

DOUBLE MOTOR - CENTRAL FRONT-BACK PICK-UP

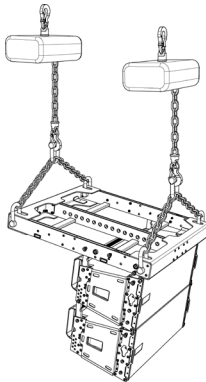

DOUBLE MOTOR - 4 CORNERS PICK-UP



**WARNING**

- Always check that the rigging motors rating exceed the total load to be suspended.
- Always check that the connection hoist rating exceed the total load to be suspended. The connection hoist must be connected using the flat part in contact to the bar and the round part connected to the motor hoist.



# TTL33-A / TTL31-A, RIGGING PROCEDURE

RIGGING THE SYSTEM FOLLOW THE PROCEDURE:

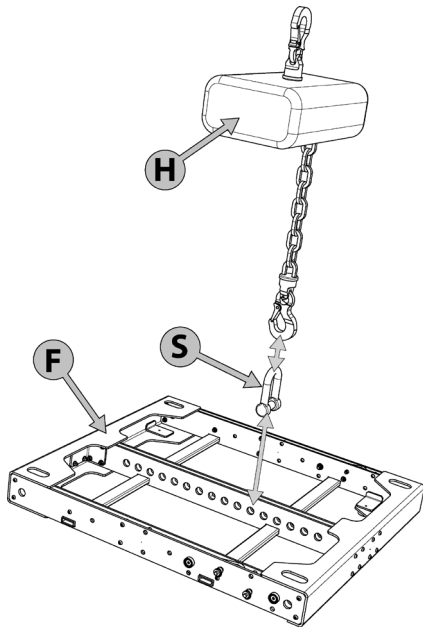

H RIGGING CHAIN HOIST

S CERTIFIED SHACKLE

F FLY BAR

**1** Connect the fly-bar F to the chain hoist H (o motors) using a certified shackle. Secure the shackle to prevent un-screwing (following the shackle supplier instructions and warnings)

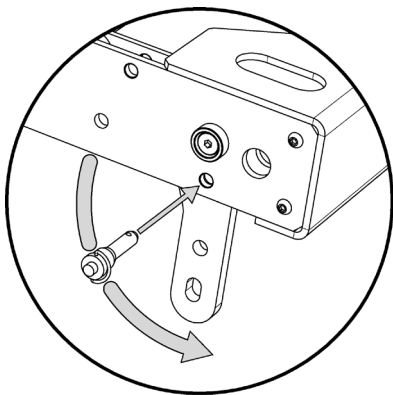

**2** Connect the second pin on the front bracket to make sure that the connecting bracket is vertical

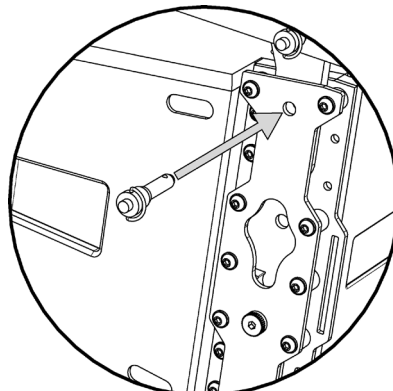
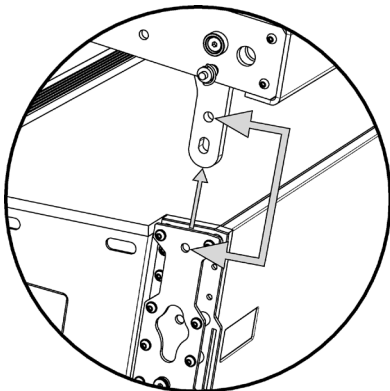

**3** Connect the front bracket to the first TTL33-A/TTL31-A cabinet using 2 quick lock pins

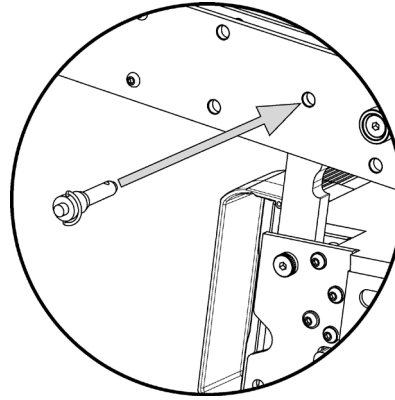
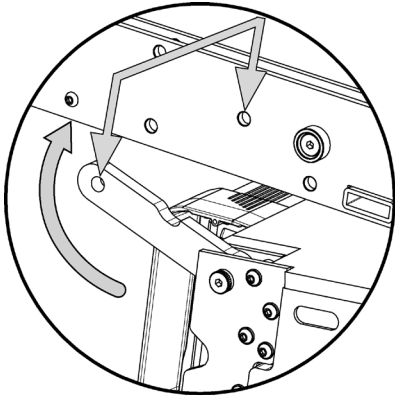

**4** Reverse and connect the 2 rear bracket to the fly-bar using 2 quick lock pins

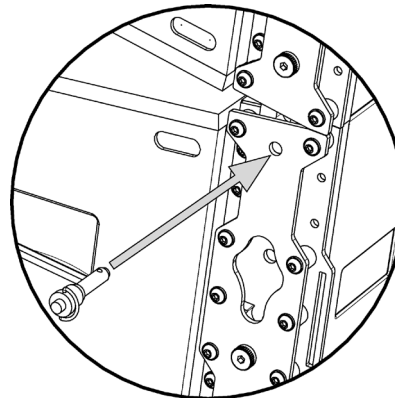
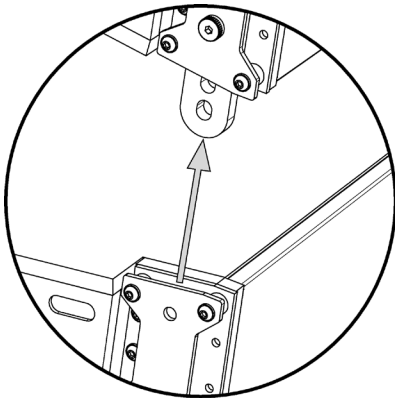

**5** Connect the second cabinet to the first always starting from the 2 front brackets

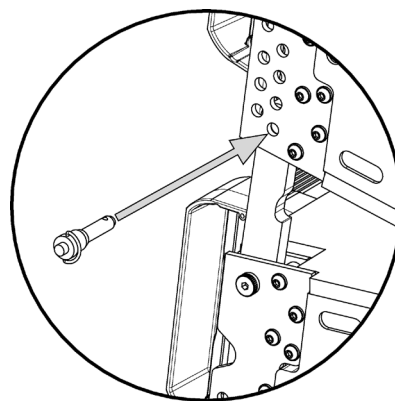
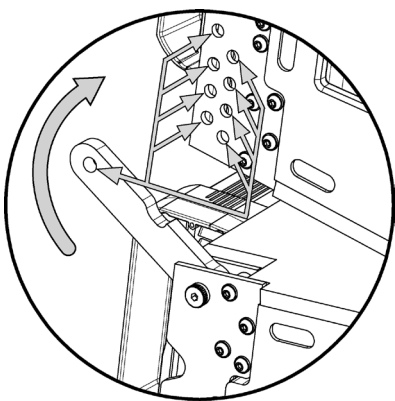

**6** Reverse and connect the rear brackets of the second cabinet using the hole for the proper angle.

**7** Connect all the other cabinets following the same procedure and connecting a single cabinet each time.

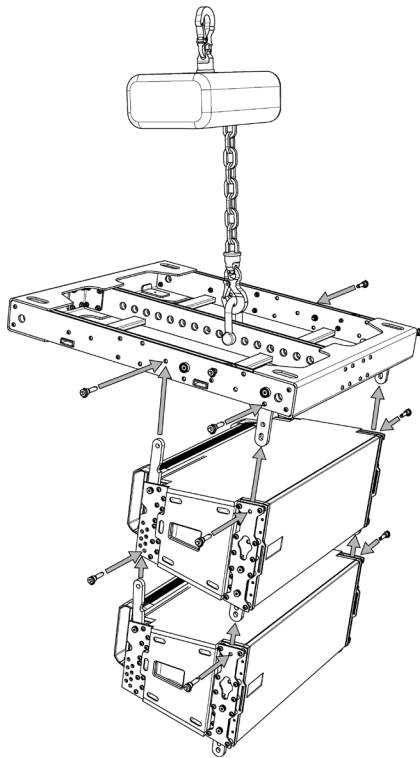

TTL33-A/TTL31-A RIGGING SYSTEM

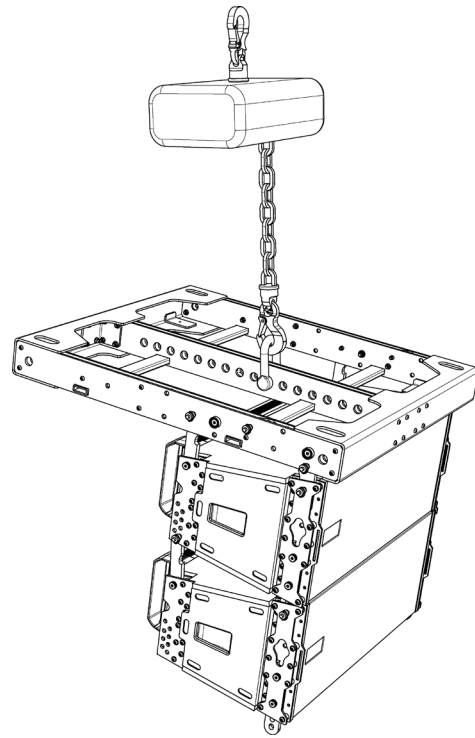

TTL33-A/TTL31-A FLOWN SYSTEM

**! WARNING**

- Always make sure that each quick locking pin is properly entered in the right position and securely locked.
- Always make sure that rear left and right angle set-up are the same.
- Rigging the array, in any case, always lock the 2 front pins at first, then the 2 rear pins. Un-rigging the array, in any case, always un-lock the 2 rear pins at first, than the 2 front pins.

**UN-RIGGING THE SYSTEM**

Un-rigging the system follow this instructions:

- remove the last cabinet un-locking the 2 rear pins at first, than the 2 front pins.
- remove all the other cabinets following the same procedure and removing a single cabinet each time.
- remove the fly-bar from the motor (o motors).

**RIGGING OR UN-RIGGING MULTIPLE CABINETS**

If the array is made of a small group of cabinet it is possible to rig or un-rig more than one cabinet a time. For example an array made of six cabinets can be rigged in two group of three cabinets, each group directly from the kart.

**! WARNING**

This procedure is generally more dangerous and it is very important to respect the following limits of application:

- NEVER CONNECT A GROUP OF CABINETS BIGGER THAN 4
- NEVER CONNECT CABINETS IN GROUPS IF THE ARRAY IS BIGGER THAN 8
- NEVER CONNECT CABINETS IN GROUPS IF THE ARRAY IS VERY CURVED
- NEVER FLY THE SYSTEM AT TEMPERATURES LESS THAN -5° C

Use the same general strategy un-rigging the system.

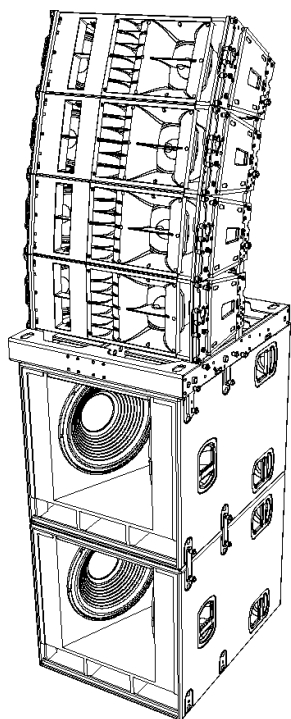

## TTL33-A GROUND STACKING

The mechanical design of the suspension system allows the TTL33A system to be either flown or ground stacked. Either method requires the array frame, the FLY BAR TTL33A.

Even the smallest of arrays benefit from a careful review of what vertical coverage is being created, and how that affects the listening environment. Typically, four TTL33A enclosures is the minimum practical array format if controlled coverage and precise directivity is a system design criteria for an event.

The figure below shows a ground stack of four boxes with a mild baffle arc setting on TT+ subs.

This array solution can be expected to provide controlled directivity. This type of compact array can work well in small venues, including concert clubs and smaller auditoriums.

In addition to its flown capabilities, the FLY BAR TTL33A frame forms a secure base for ground-stacking having rubber feet already installed.

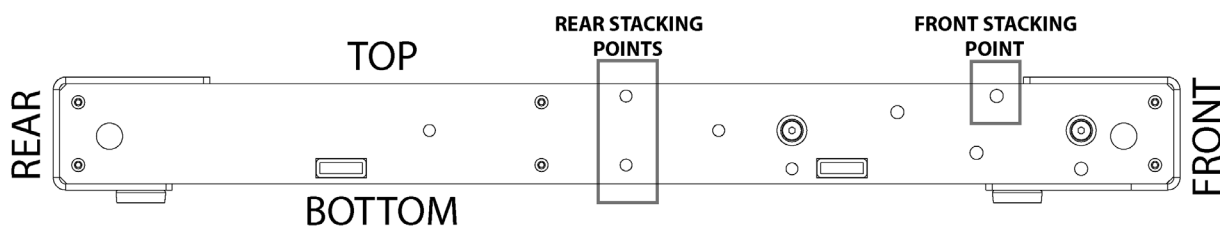

For ground-stacking are necessary optional STCK BAR TTL33A rigging frames and additional quick release pins.

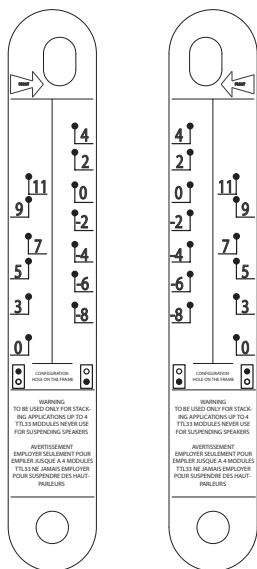

figure: STCK BAR TTL33A for connecting TTL33A

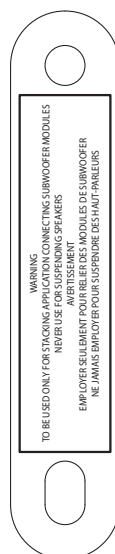
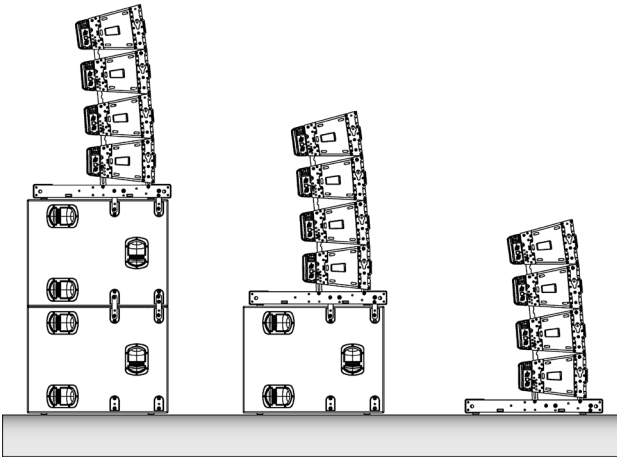
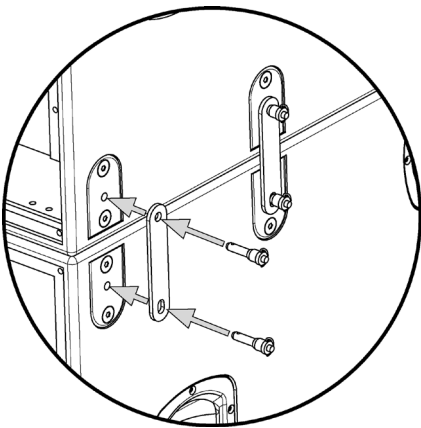

figure: STCK BAR TTL33A for connecting subs



Ground stacking configurations: on subs and directly on the ground

TTL33A loudspeakers can be stacked by themselves on the FLY BAR TTL33A, or can be placed on top of TT+ subwoofers (with the same FLY BAR TTL33A fitted with the optional STCK BAR TTL33A rigging frames) pinned to the grid.



Secure sub enclosures with the optional STCK BAR TTL33A rigging frames for subs using 2 quick lock pins for each bracket

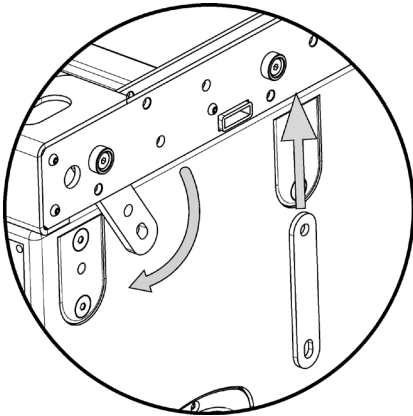

Reverse FLY BAR TTL33A front bracket and use the optional STCK BAR TTL33A rigging frames for subs for securing the frame to subs enclosures.

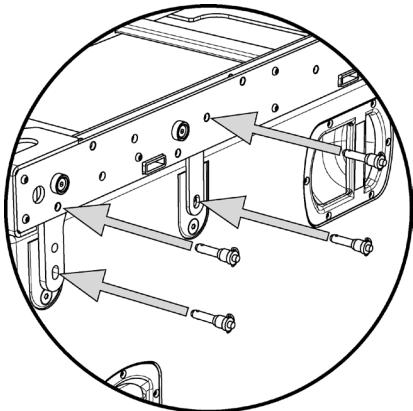

Connect the optional STCK BAR TTL33A rigging frames for subs and the FLY BAR TTL33A front bracket using 2 quick lock pins for each bracket.

The STCK BAR TTL33A link adds a fixed amount of up or downtilt to ground-stacked TTL33A loudspeakers, with additional 19 degrees of adjustment possible (from +11° to -8°).

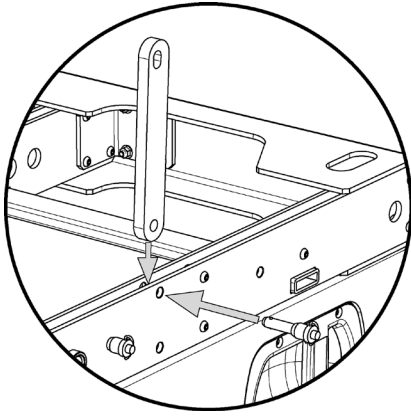

Use the optional STCK BAR TTL33A rigging frames for satellite enclosures for securing them to the frame.

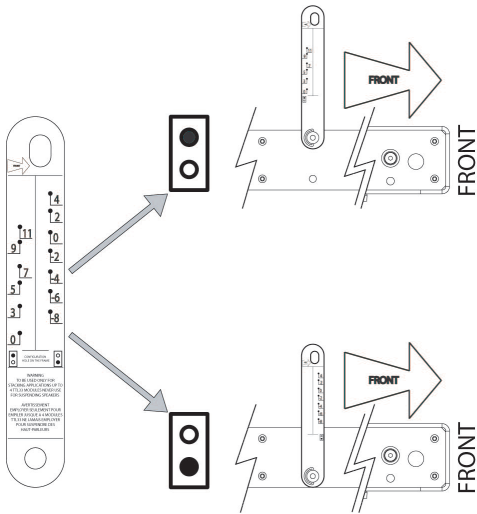

Depending on the two different holes on the FLY BAR TTL33A frame various tilt angles of the whole array are possible. Check the acoustical and mechanical set up with SHAPE DESIGNER software for stacked set ups.

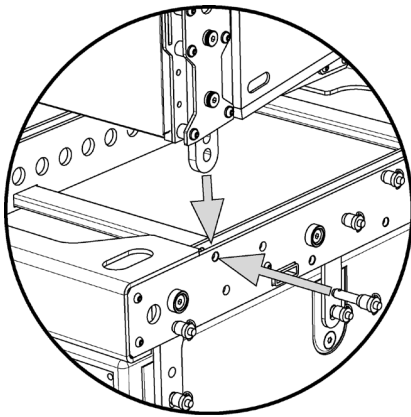

Connect front bracket of the first TTL33-A cabinet using 2 quick lock pins

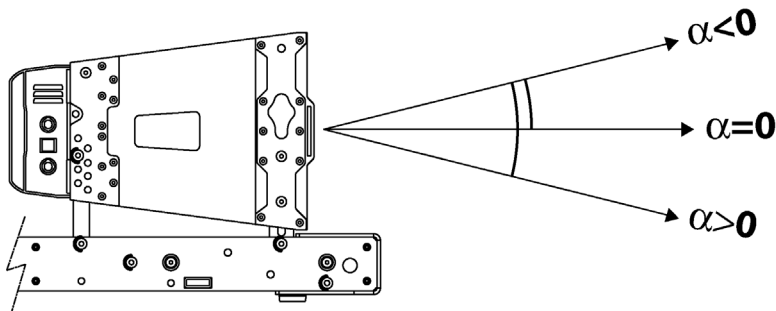

The baffle of the bottom box in a stacked array does not necessarily have to be parallel to the stage or the array frame. It can be tilted up or downward if desired. In this way arced arrays can be readily created from a ground stack position.

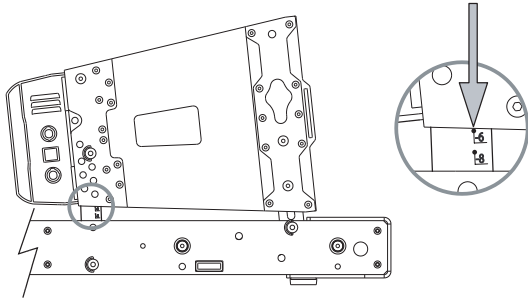
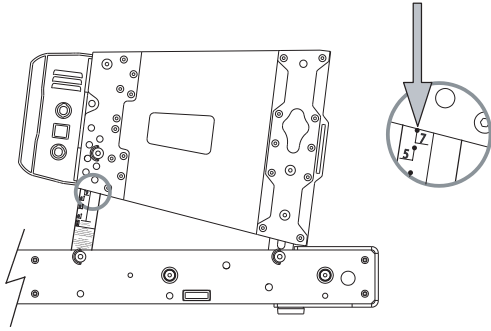

The bottom box in a stacked array can be tilted with 2 degrees steps to obtain proper coverage patterns (from +11° to -8°) as shown in the figure.

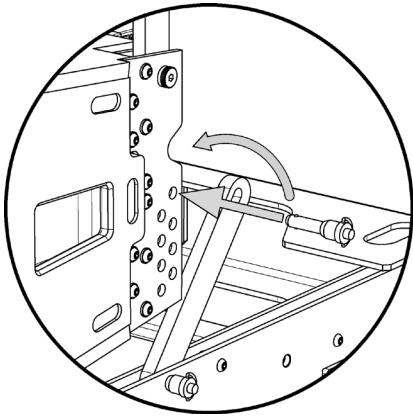

Reverse and connect the 2 rear STCK BAR TTL33A bracket to the first enclosure using the hole for the proper angle and quick lock pins

Add TTL33A cabinets one by one as indicated for flown configurations. Up to four TTL33A enclosures can be stacked and interlinked using the standard TT+ rigging components and the FLY BAR TTL33A flying frame as ground support.

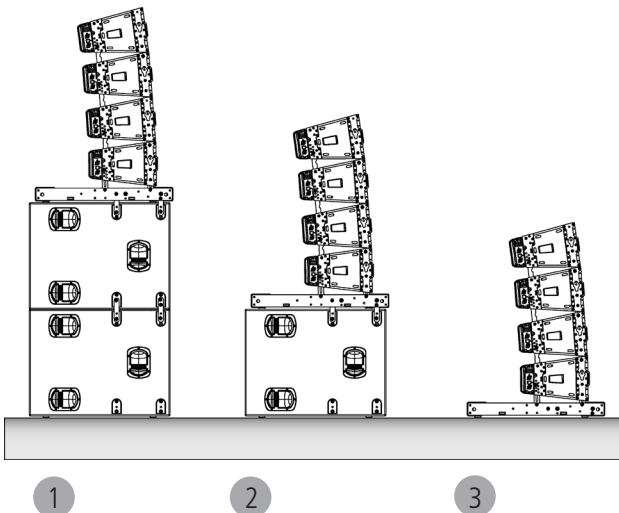

Ground stacking summary: possible configurations

The configuration No. 1 requires:

No. 1 Stack bar accessory STCK BAR TTL33A p/n 13360057 of which all bars will be used, and additional Nos 16 pins (Nos 4 AC-QL PIN4X p/n 13360060).

The configuration No. 2 requires:

No. 1 Stack bar accessory STCK BAR TTL33A p/n 13360057 of which only 2 bars type A) and 2 bars type B) will be used, and additional Nos 8 pins (Nos 2 AC-QL PIN4X p/n 13360060).

The configuration No. 3 requires:

No. 1 Stack bar accessory STCK BAR TTL33A p/n 13360057, of which only 2 bars type B) will be used, and no additional pins are required.

## RCF TTL33-A KART

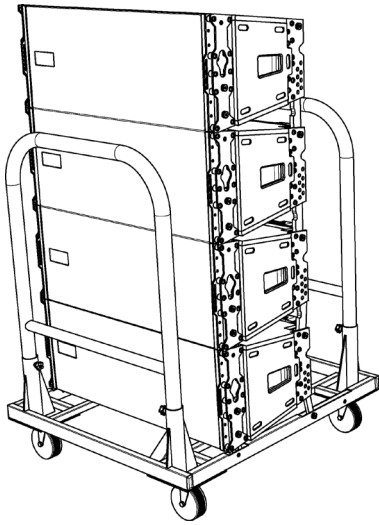

The heavy duty RCF TTL33-A Kart can be use to easily transport up to 4 TTL33-A cabinets. The cabinets and Kart are fully compatible and it is possible to easily transport TTL33-A cabinets in straight or splayed configurations.

It is possible to transport 4 TTL33-A modules with the fly-bar connected, making sure that the total system centre of gravity is properly in centre of the kart.

### **WARNING**

- Do not exceed 4 cabinets transportation. A bigger number of cabinet can cause tipping over the stack.
- Always take care, in case of splayed configurations, that the centre of gravity of the system is properly in centre of the kart. It is always possible to adjust the centre of gravity position choosing an appropriate angle between the first cabinet and the kart.



# 6. SOUND DESIGN

The RCF TTL33-A loudspeaker employs a unique combination of drivers to enable you to optimise both coverage and directivity in a TTL33-A line array system. To achieve optimal results, it's important to understand how these components work together.

## HOW LINE ARRAYS WORK

Line arrays can provide increased gain compared to other methods of arranging loudspeaker elements. An understanding of how specific radiating devices operate allows the creation of effective line-source arrays. In the realm of loudspeaker systems, a line-source array is a group of similar-sized sound-radiating sources that provide increased directivity at various frequencies. This directivity, known as the Line Array summation effect, can be predicted based on known characteristics of the individual sources and the size and height of the array, along with center-to-center spacing of the acoustic sources. Line arrays achieve directivity through constructive and destructive interference. The loudspeaker's directivity varies with frequency: When the wavelengths being reproduced are larger than the driver at low frequencies it is omni directional; as the frequency increases (and the wavelength is comparable to the size of the driver), directivity narrows. For example, stacking two loudspeakers one atop the other and driving both with the same signal results in a different radiation pattern. At common points on-axis, there is constructive interference, and sound pressure increases by 6 dB relative to a single unit. At other points off-axis, path length differences produce cancellation, resulting in a lower sound pressure level. In fact, if you drive both units with a sine wave, there will be points where the cancellation is complete. This is destructive interference, sometimes referred to as combing. A typical line array comprises a line of loudspeakers carefully spaced so that constructive interference occurs on-axis of the array, and destructive interference (combing) is aimed to the sides. While combing has traditionally been considered undesirable, line arrays use combing to positive effect: to control the directivity.

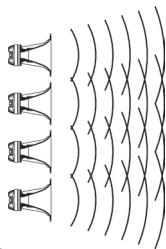

wave front interference

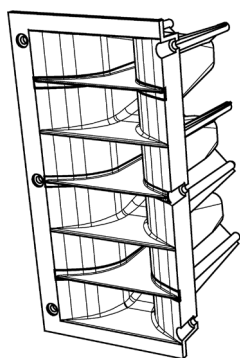
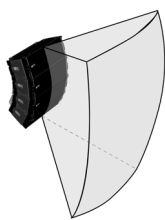

RCF wave guide horn

For high frequencies, TTL33-A/TTL31-A uses very precise Constant Q horns which provide a consistent beamwidth of coverage in both the vertical and horizontal planes. By properly aligning the acoustic sources and observing the wavelength-related spacing, the combined output takes on the characteristics of a coherent wave front within the pass-band of the high frequency devices.

In the vertical pattern RCF wave guide horn-loading provides narrow coverage in order to minimize destructive interference between adjacent elements and promote coupling to throw longer distances. As more elements are arrayed in a vertical column, they project mid- and high-frequency energy more effectively through coupling. The amount of energy can then be controlled using the relative splay between the elements.

Curving a line array can aid in covering a broader vertical area, while narrow angles provide a longer throw and coverage which more closely matches that of the mid-low frequencies. The horizontal directivity of a line-source array will typically be the same as that of one of the single elements within the array and is independent of both the number of arrayed enclosures and the vertical configuration of the array. In the horizontal pattern of the array, RCF wave guide horns work to produce a wide 100-degree coverage for TTL33-A/TTL31-A. Due to the coplanar symmetric arrangement of components, the horizontal coverage is symmetric with respect to the 0° axis.

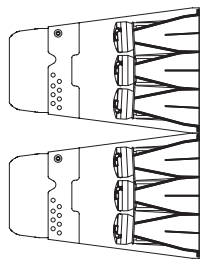

0° between adjacent enclosures

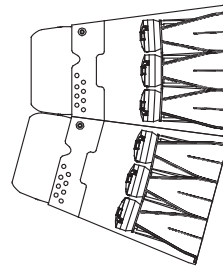

15° between adjacent enclosures

This 100° coverage angle also defines the recommended limit for the relative angle between TTL33-A/ TTL31-A arrays, for example, when main L/R FOH TTL33-A/ TTL31-A arrays are oriented at zero degrees, offstage LL/RR arrays can be oriented at up to 100° relative to the main L/R arrays while maintaining a 6-7 metre separation between arrays in order to maximize overall system coverage while reducing the audible effects of interference.

For the mid to low frequencies, line arrays must be coupled together to narrow their vertical coverage and project mid and low energy to the far field. The directional control of the array is achieved when the length of the array is similar or larger than the wavelength of the frequencies being reproduced by the array. As frequencies get lower and wavelengths get longer, the number of cabinets has a critical effect but the splay angle between cabinets has little effect since the total length is not modified substantially. The number of array elements, however, is important: the more TTL33-A/ TTL31-A loudspeakers used, the more directional the vertical beamwidth becomes at the lower frequencies.

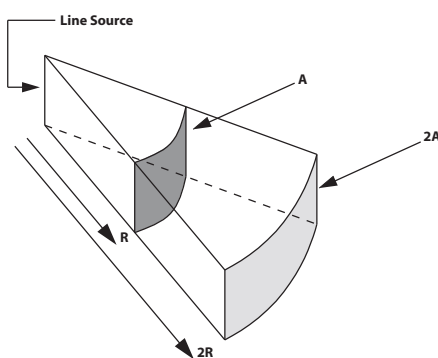

Cylindrical wave expands in horizontal dimension only at 2R surface area increase 2 times -> 3 dB attenuation

Apart from coverage precision and predictability, another significant benefit of TTL33-A/ TTL31-A is the fact that the system effectively extends the near field region at higher frequencies. For flat TTL33-A/ TTL31-A arrays, this results in a 3 dB reduction in SPL with doubling of distance as opposed to the 6 dB reduction that is typical of conventional systems. This property arises due to the physics of cylindrical waves versus spherical waves. Due to its ability to perform planar wave front, TTL33-A/ TTL31-A has different attenuation properties than conventional systems. Comparing SPL predictions according to standard calculations is not meaningful since TTL33-A/ TTL31-A produces a combination of cylindrical and spherical wave front propagation that must be evaluated using specific calculations. When curved TTL33-A/ TTL31-A arrays are employed, there is a combination of cylindrical and spherical propagation. Although pure cylindrical wave propagation is not always in effect, 3 dB reduction with distance can still be obtained along with extension of the near field by correctly focusing the system on the audience. Psycho acoustically, near field extension allows one to walk a considerable distance from a TTL33-A/ TTL31-A system with only a small difference in SPL due to the system's unconventional attenuation rate

## DISTANCE TO THE FAR FIELD OF A LINE ARRAY\*

(\* from AES Convention paper Presented at the 110th Convention 2001 May 12-15 Amsterdam)

The analysis of line arrays relies on a far field assumption, that is, that the distance to the point of observation P is large compared to the length of the array. The far field is characterized by sound pressure level decreasing at 6dB for every doubling of distance. In the near field the sound pressure level undulates and decreases nominally at 3dB per doubling of distance.

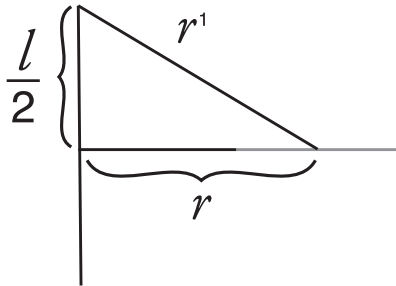

Geometric construction for far field distance

The transition point can be estimated if we set as a criterion that the far field is reached when the distance to P from the centre point of a line array is within a quarter-wavelength of the distance to P from the endpoint of the array.

Referring to the previous figure, the far field is obtained when

$$r = r' - \frac{\lambda}{4}$$

where r is the distance to P from the centre point and r' is the distance from the endpoint. Solving for r',

$$r' = \sqrt{\left(\frac{l}{2}\right)^2 + r^2}$$

where l is the length of the array. Rewriting, the distance to the far field is

$$r = \frac{l^2}{2\lambda} - \frac{\lambda}{8} \quad l \geq \frac{\lambda}{2}$$

the square of the array length and inversely proportional to wavelength. For most applications, the second term can be dropped. For convenience, the far field equation for a line array can also be expressed in terms of frequency rather than wavelength. Two useful forms are:

$$r \approx \frac{l^2 f}{700} \quad (l \text{ in meters, } f \text{ in Hz})$$

and

$$r \approx \frac{l^2 f}{2300} \quad (l \text{ in feet, } f \text{ in Hz})$$

## SYSTEM CONFIGURATIONS

In practice, not all line arrays can be straight lines, i.e., depending on the application and needs, it may be necessary to curve the array in order to achieve sufficient coverage throughout the audience areas. For this reason, each box that makes up the "line array" must incorporate a rigging system that allows aiming in the vertical plane. It is important to note that the rigging system, as well as being integral to the units, needs to allow for hinging at the front of the box so that the separation between the speakers remains the same (hinging at the back of speakers would increase the vertical spacing, which works against line array theory). Thus, curved systems are frequently used.

## CURVED ARRAY

A curved array is comprised of radiating elements arranged along a segment of a circle. It generally provides a wider directivity response than a straight-line array. At high frequency, it provides a polar pattern corresponding to the included angle of the arc. There exist limitations with respect to the maximum allowable splay angles to comply with the theory. One of the conditions is specified on the following sentences: a) for curved arrays, the vertical splay angles must vary inversely with the distance to the listening location. I.e., for the farthest positions the splay angle will be small, and will widen progressively as the listening point gets closer to the "line array". b) the vertical coverage of a curved array is given by the size or height of each box, the splay angles between boxes and the number of units being flown.

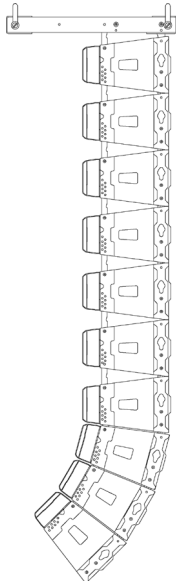

## "J" ARRAY

A J-Array is comprised of a straight line array and a curved array. Generally the straight segment is located above the curved segment and is intended to provide the long throw component of the polar response. The curved segment is intended to provide coverage in the relative near field(f) below and in front of the array. Together, the segments provide an asymmetric polar response in the vertical plane.

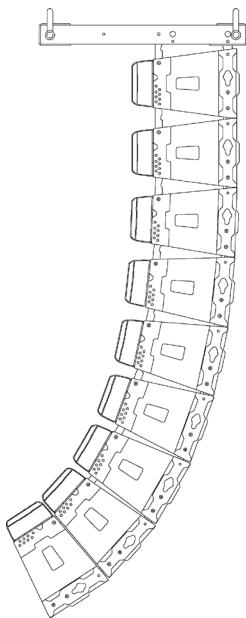

## SPIRAL ARRAY

Like the J-array, a spiral array provides an asymmetric polar response in the vertical plane. However, unlike the J-array, it is a continuous curve rather than two distinct segments. The curvature increases with distance along the curve. This results in an upper portion that is largely - but not perfectly - straight, and a lower portion that is curved downward. There are many types of spirals providing various rates of curvature. The relevant set of spirals for arrays of loudspeaker enclosures are those for which the curvature changes at predetermined intervals of length along the spiral. This length interval corresponds to the height of the enclosure. An arithmetic spiral is one for which the angle between successive enclosures changes by a predetermined angle  $\Delta$ . For example, the top box might be hung at  $0^\circ$ , the next box at  $1^\circ$ , the next at  $2^\circ$  and so on. This defines a spiral where the angle of the nth box is oriented to the vertical axis by  $0^\circ, 1^\circ, 3^\circ, 6^\circ, 10^\circ$  and so on - an arithmetic expansion. An incremental angle of  $2^\circ$  would yield  $0^\circ, 2^\circ, 6^\circ, 12^\circ, 20^\circ$  and so on.

RCF Shape Designer calculates the optimum progressive curvature for a given audience area. The progressive curvature produces a more consistent frequency response from the front rows to the rear seats than often used J-shaped arrays having a straight, long throw section at the top and a curved lower section. An over-angular J-shaped array acts like a foreshortened straight array above a point source array and creates vertical lobes that result in irregular coverage.

## STEREO IMAGING: THE LEFT/RIGHT CONFIGURATION

Although not the best technical solution, the left/right configuration meets both visual and practical criteria and is most commonly used. By nature, the stereo imaging of any left/right system is limited for a large part of the audience and there are compromises with respect to the consistency of tonal balance in the horizontal plane. The left/right configuration has the advantage of being able to reproduce effects of spatialization and localization. The area over which these effects is audible depends on the separation of the two arrays and the orientation of the left array with respect to the right array, defined by the intersection of the coverage for both arrays. More the arrays are rotated or panned onstage, greater is the area over which stereo imaging is experienced. Less they are rotated onstage and more they are aimed offstage, less stereo imaging is audible. Typically, for concert applications L/R arrays are separated 15-20 meters and used at zero degrees. Experience has shown that this provides the best trade-off between stereo imaging, evenness of horizontal coverage and reduction of the potential for build up of low frequency and upper mid bass energy in the centre.



## LEFT/CENTRE/RIGHT (LCR) CONFIGURATIONS

Although it can be sometimes difficult to negotiate the centre position (from a visual standpoint), LCR systems offer more flexibility in optimising audience coverage with the potential for improved intelligibility, more even horizontal tonal balance and better image localization compared with standard LR configurations. When using the LCR configuration for live music applications, three TTL33-A/TTL31-A arrays can be installed with the C array at 0 degrees and the L/R arrays panned offstage up to 50 degrees (for speech reinforcement, L/R arrays can be panned offstage up to 100 degrees to optimise coverage and intelligibility). For theatrical sound reinforcement, the 100 degree coverage of TTL33-A/TTL31-A is highly recommended to centre cluster applications and L/R coverage for the typical 12-15 metre L/R array separation that occurs in theatres.

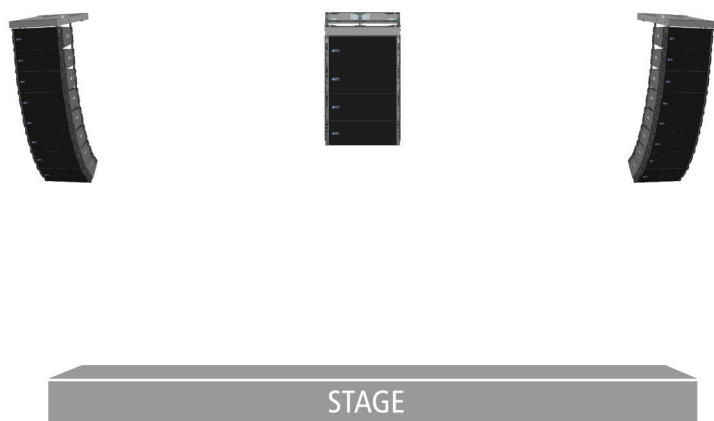

## MULTIPLE ARRAY (>100° horizontal coverage)

When the horizontal coverage of a TTL33-A/TTL31-A array (100° nominal) is not sufficient, it is not recommended to place a second array directly beside the first one. The best approach is to utilize a second array which is focused on another portion of the audience (typically at 60° - 100° relative to the first array) and spaced at least 6-7 meters (approximately 20 ft) from the first array. By focussing main and offstage fill arrays at different panning angles, audible comb filtering interaction is lessened since the overlap region between the two arrays is reduced. The main L/R FOH arrays are normally physically larger than the offstage side fill arrays and act as the reference for time alignment. Typically, a side fill array is delayed with respect to the FOH array. To geometrically improve time alignment in the overlap region between the main and offstage arrays, the location of the offstage array should follow the arc of a circle with the radius of the circle at upstage centre.

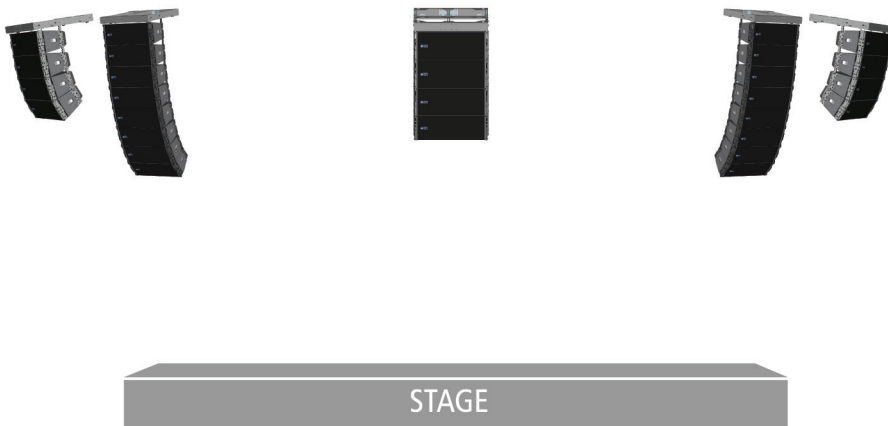

The offstage fill system should be time aligned towards the direction where both array produce equal level. Time alignment of a horizontal array.

The delay time value  $\Delta t$  is equivalent to the physical offset  $\Delta x$  divided by the speed of sound (i.e. 343 m/s)

$$\Delta t = \frac{\Delta x}{v_{\text{sound}}}$$

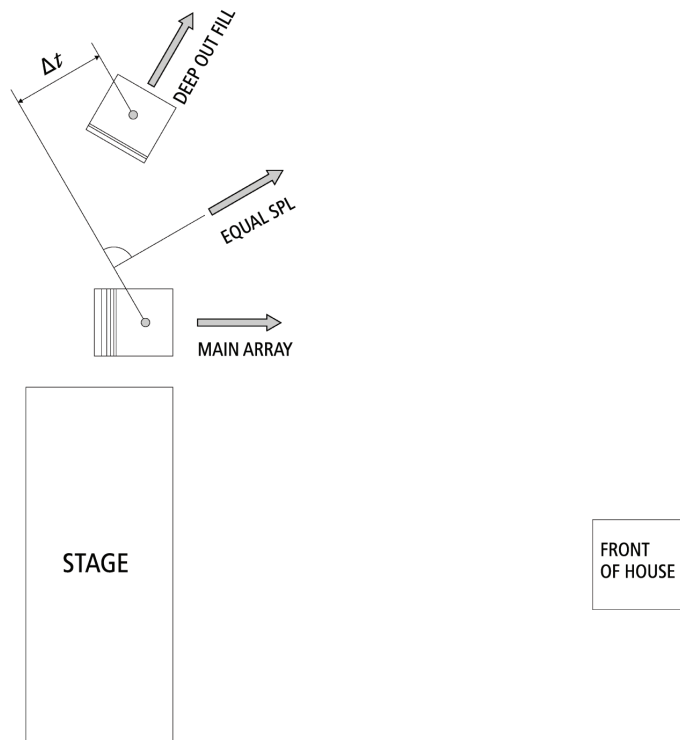

Time alignment of a horizontal array

## ARRAY SYSTEMS DESIGN

TTL33-A/ TTL31-A allow users to choose from different face-to-face angle adjustments to create arrays with varying curvature. Thus, designers can create arrays custom-tailored to each venue's profile.

The basic approach to array design dependent on three factors:

- Number of Array Elements
- Vertical Splay Angles
- Horizontal Coverage.

Determining the number of elements to use is critical: the number of elements greatly affects the SPL available from the system as well as the uniformity of coverage in both SPL and frequency response. The number of elements profoundly effects the directivity at lower frequencies. The next easy equation, works as an approximation for flat listening planes.

$$\begin{array}{l} \text{Coverage (x)} \approx 10n \text{ (m)} \\ \quad \approx 6n \text{ (N)} \end{array} \quad \left| \begin{array}{l} \text{Coverage distance required} = x \text{ (metres)} \\ \text{Number of boxes} = n \text{ (TTL33-A/TTL31-A enclosures)} \end{array} \right.$$

Changing the splay angles between cabinets has a significant impact on vertical coverage for the high frequencies, with the result that narrower vertical splay angles produce a higher Q vertical beamwidth, while wider splay lowers the Q at high frequencies. In general, the splay angles do not affect the vertical coverage at lower frequencies.

The curved array system design can be summarized as:

- flat-front TTL33-A/TTL31-A s for long throw sections
- increase curvature as distance decreases
- add more enclosures for more output.

This approach focuses more transducers mounted on long-throw horns at the farthest seat, gradually focusing fewer transducers as distance decreases. As long as the no gap rule is maintained, arrays constructed according to these principles will provide even SPL and a consistent sonic character throughout the venue without requiring complex processing.

This approach, where the same amount of acoustic energy is spread over a larger or smaller vertical angle depending on required throw, typically have the following objectives:

- even horizontal and vertical coverage
- uniform SPL
- uniform frequency response
- sufficient SPL for the application

This discussion represents, of course, just a basic approach. Given the infinite variety of venues and performers, users will find themselves needing to solve specific problems in specific situations. RCF Shape Designer software designed to help calculate optimum splay angles, aiming angles, and fly-bar pick points (crucial in aiming the array) for a given venue, will be explained later in this Guide.

## RCF SHAPE DESIGNER SOFTWARE

### INSTALLING RCF SHAPE DESIGNER

RCF Shape Designer is supplied in a zip folder which contains a setup executable file:



Double-click on this and follow the on-screen prompts.

## COMPUTER REQUIREMENTS

The RCF Shape Designer requires an IBM compatible PC with the Windows® 98, Windows® 98SE, Windows® 2000, Windows® ME, Windows® XP, or Windows NT® operating systems. It is not designed to work with Windows® 3.x, Windows® 95, or Macintosh® operating systems.

## INTRODUCTION

Use the RCF Shape Designer for designing TTL33-A arrays. The RCF Shape Designer's primary function is to determine the configuration that will provide the best vertical performance for a given application. Various venue dimensions are entered that allow the RCF Shape Designer to calculate the resultant array performance.

## USING RCF SHAPE DESIGNER SOFTWARE

Once you have installed RCF Shape Designer, it will be visible as a shortcut in All Programs via your Windows Start button.



A single click on the RCF Shape Designer tab will open the following page:



A single click on the window will open the following page:

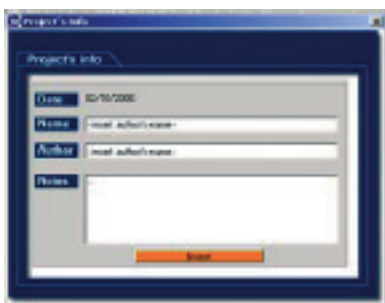



Filling the blank tabs it's possible to start the program:

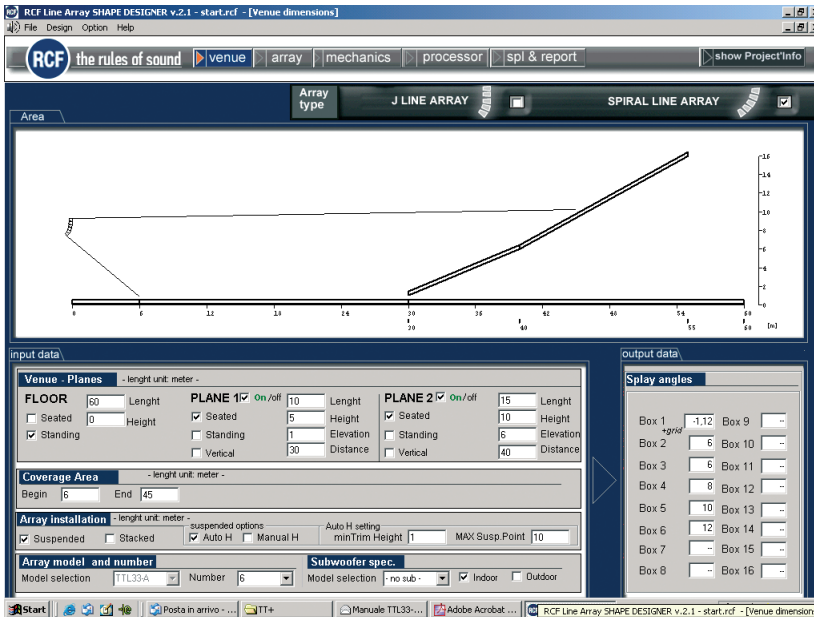

## ENTERING VENUE DATA

For best results, planes should be used as follows:

Floor is used to simulate the main floor area from the stage to a rear bleacher or boundary.

Plane 1 is used to simulate any audience continuation behind Floor (e.g. a rear bleacher) from the end of the main floor to furthest and highest seat below Plane 2.

Plane 2 is used to simulate the furthest/highest audience area.

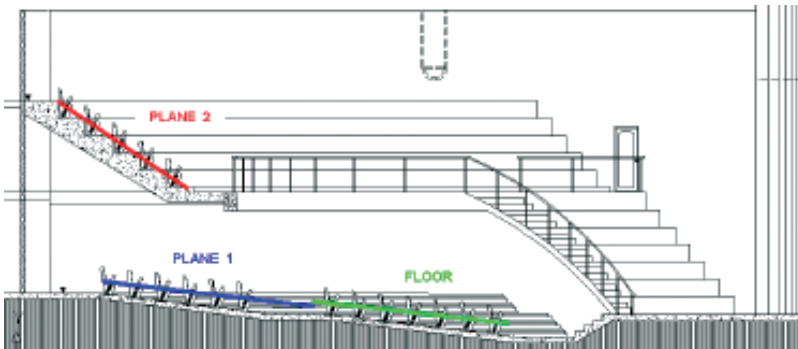

*Example: audience modelling*

Enter the height, length and elevation of up to three planes.

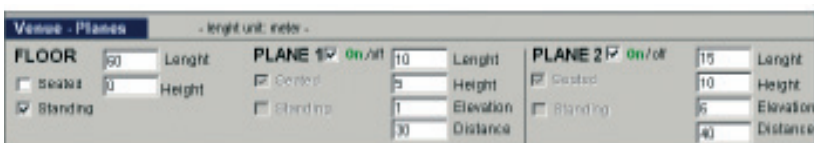

For all planes **Length** refers to the horizontal length of that plane

For all planes **Height** refers to the height of the rear of the plane.

For planes 1 and 2 **Elevation** refers to the elevation (height) of the front of the plane.  
 For plane 1 and 2 **Distance** relates to the actual distance from the front of the array to the start of the plane.  
 For all planes selecting **Seated or Standing** places ear level at 1.3 or 1.7m above the respective plane.  
 Filling the blank tabs it's possible to start the program:

## COVERAGE

Specify the horizontal coverage distances from the front of the array.

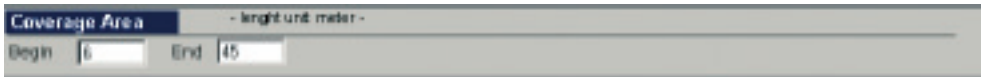

## ARRAY INSTALLATION

Select either Suspended or Stack in the Array installation section to determines how the array is supported.

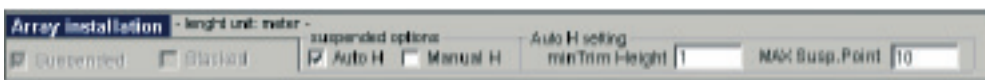

In Suspended mode the grid is suspended and cabinets are attached beneath.  
 In Stack mode the grid forms a base and cabinets are placed on top.

## SUSPENDED MODE

### AUTO H SETTING - MIN TRIM HEIGHT

This is the low limit for the array and is defined as the smallest allowable distance from the lowest point of the array to the ground below

### AUTO H SETTING - MAX SUSPENSION POINT

Set this to the maximum array height allowable (usually the highest part of the flying frame). The maximum pick height is usually chosen to allow for the maximum flying point height minus a sensible allowance for any shackles, stingers, bridles or flying hooks. 1m should be allowed for a stinger between each grid flying lug and the relevant motor hook to ensure that motor chain bags do not rest on the grid or top cabinet and upset its tilt angle.

### MANUAL H SETTING

In manual installation mode it is possible to enter the height required for flying the system.



## NUMBER OF CABINETS AND MODEL SECTION

Array model and number of cabinets can be set depending also on cabs availability.



# RCF SHAPE DESIGNER RESULTS

## VENUE PAGE

- Graphical representations of the array and the venue
- Aiming splay angle between each pair of enclosures

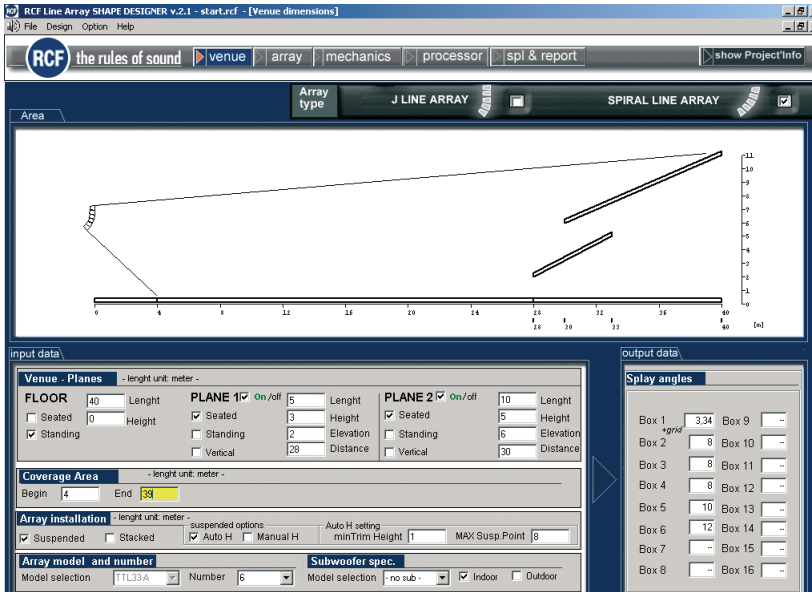

## ARRAY PAGE

- Height of the array and trim height to the bottom of the array from the floor
- Pick Point on the Fly-Bar to achieve the calculated array angle when suspended
- Weight of the array
- Mechanical check result

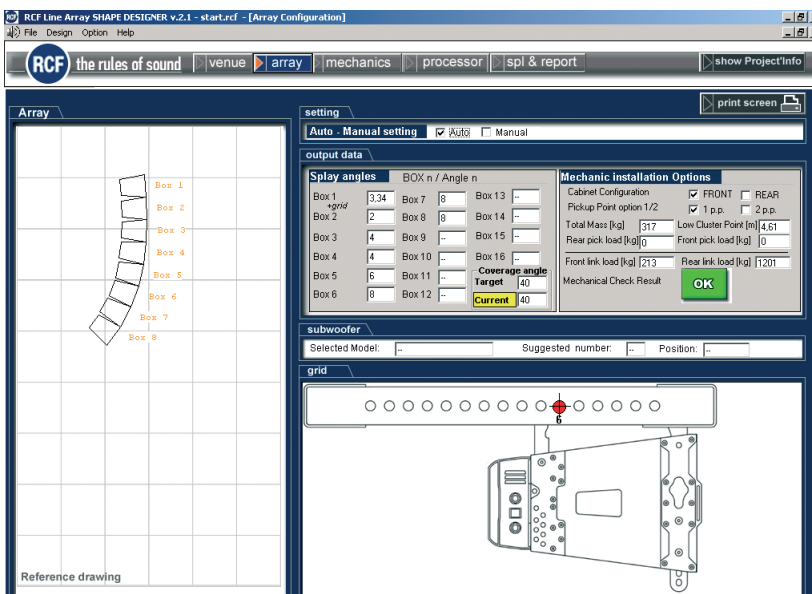

## MECHANICS PAGE

- Cluster Mechanical specifications
- Mechanical safety factors

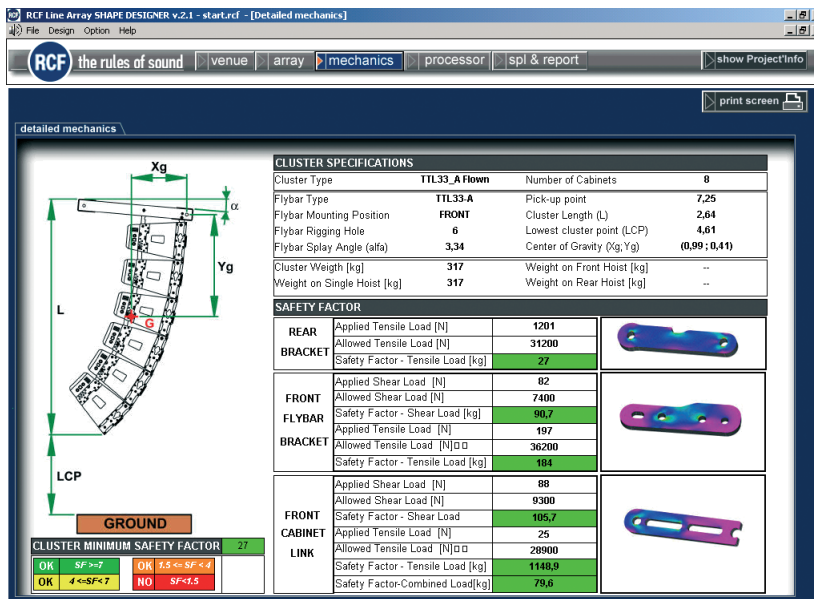

## PROCESSOR PAGE

- DSP preset configuration

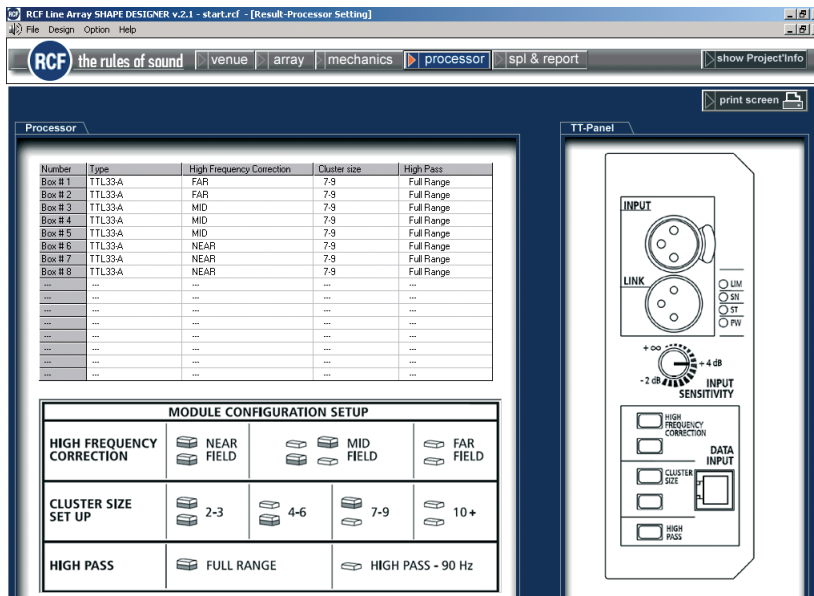

## SPL & REPORT PAGE

- On-axis aiming angle for each enclosure as a difference from 0° horizontal
- Various angles and throw distances calculated from the venue's dimensions
- DSP preset configuration
- SPL representation on the audience area

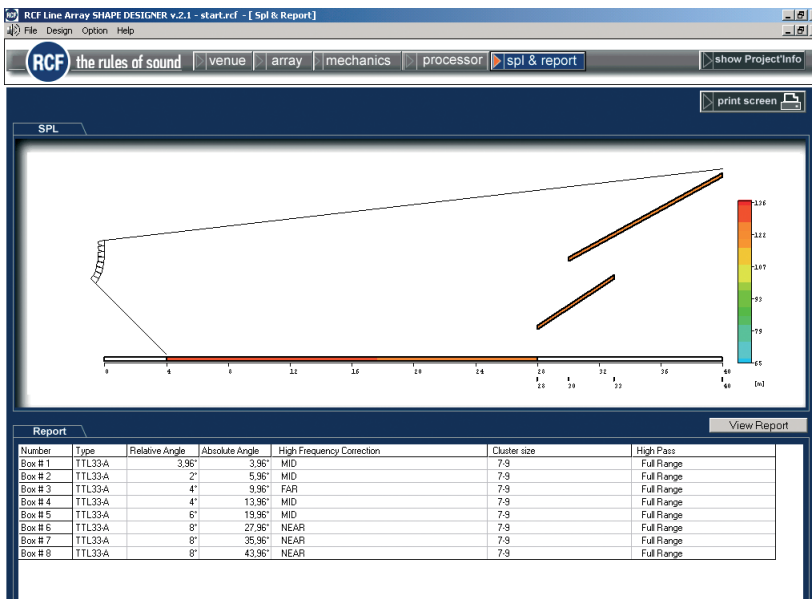

**WARNING:**

It is possible to display different pages only in sequence (venue • array • mechanics • processor • SPL & report, and back), in order to be sure that all pages will be shown to the user, including the one regarding mechanics.

**MANUAL MODE**

RCF Shape Designer works in either of two basic ways:

AUTOMATIC MODE (DEFAULT SETTING): The RCF Shape Designer will select the optimum enclosure splays, array aiming angle, fly-bar pick point and DSP preset configurations.

MANUAL MODE: this provides a partial control over the array's configuration. The enclosure splays can be increased with a progression of 2° steps for each adjacent speaker, in order to maintain a spiral array configuration. Then array aiming angle, and fly-bar pick point can be entered manually by switching on "box1 + grid changeable" and "Manual H" flags.



Array window: Manual splays setting

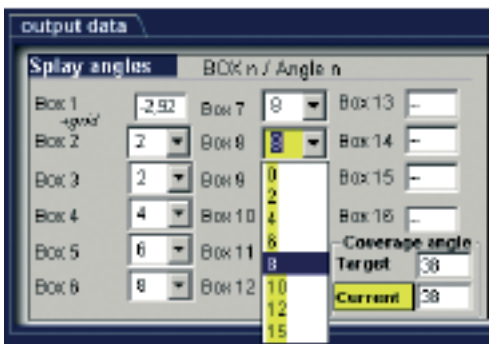

Angles manual changing

# CLIMATIC EFFECTS

When working in large venues or outdoors it's always necessary to remember that sound propagates through air and is affected by air temperature, humidity and wind.

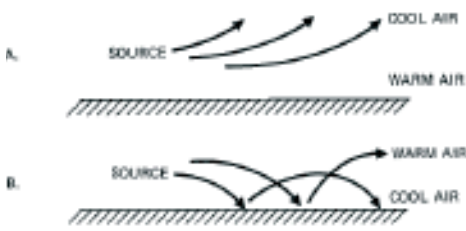

Effects of temperature gradients on sound propagation

## EFFECTS OF TEMPERATURE GRADIENTS ON SOUND PROPAGATION

If sound is propagated over large distances outdoors, its behaviour may seem erratic. Differences (gradients) in temperature above ground level will affect propagation as shown in next figure. Refraction of sound refers to its changing direction as its velocity increases slightly with elevated temperatures. At next figure, particular A, we observe a situation which often occurs at nightfall, when the ground is still warm. The case shown at B may occur in the morning, and its "skipping" characteristic may give rise to hot spots and dead spots in the listening area.

## EFFECTS OF WIND VELOCITY AND GRADIENTS ON SOUND PROPAGATION

Next figure shows the effect wind velocity gradients on sound propagation. The actual velocity of sound in this case is the velocity of sound in still air plus the velocity of the wind itself. The following figure shows the effect of a cross breeze on the apparent direction of a sound source. The effects shown in these two figures may be evident at large rock concerts, where the distances covered may be in the 200 - 300 m range.

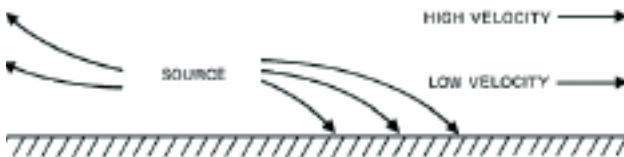

Effect of wind velocity gradients on sound propagation

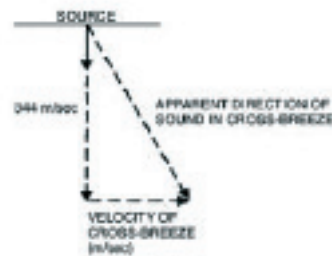

Effect of cross breeze on apparent direction of sound

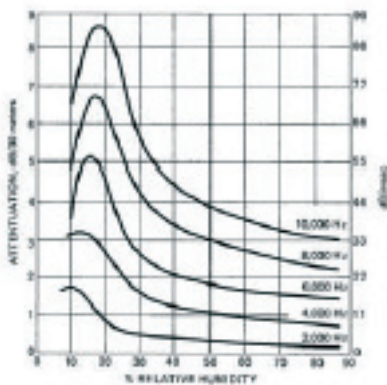

Absorption of sound in air vs. relative humidity

## EFFECTS OF HUMIDITY ON SOUND PROPAGATION

Contrary to what most people believe, there is more sound attenuation in dry air than in damp air. The effect is a complex one, and it is shown in the next figure. Note that the effect is significant only at frequencies above 2 kHz. This means that high frequencies will be attenuated more with distance than low frequencies will be, and that the attenuation will be greatest when the relative humidity is 20 percent or less.

Under the above conditions air absorption at 10KHz can reach 0.3dB/m at 20% RH. This means 30dB excess attenuation (over and above the 3dB per doubling of distance) at 100m from the column. The incredible high frequency efficiency and headroom of the TTL33-A can prove beneficial here. Air absorption also varies with temperature and is notoriously difficult to predict with accuracy.

The best policy is to get your crew to check all audience areas during the performance and apply a sensible amount of correction. Luckily, a large audience tends to raise the local humidity so HF absorption often reduces once the audience is in place. Line array systems should be corrected with caution and distant audience areas rechecked at regular intervals during large events.

## HIGH-FREQUENCY COUPLING EFFECTS

Planning for high-frequency coverage is a matter of deciding the number of elements and fine-tuning the splay angles between cabinets. The number of elements does not necessarily have a significant impact on SPL at high frequencies (it will at low frequencies), but can profoundly affect vertical coverage and throw capabilities of the array.

For the far field, a smaller mechanical splay angle between cabinets achieves superior throw through better coupling to compensate for energy lost over distance. The longer the throw needed, the more elements needed with smaller angles at the top of the array. In the near- to mid-field, larger splay angles are used to increase vertical coverage.

## LOW-FREQUENCY COUPLING EFFECTS

While wave-guides provide isolated control over various mid- to high-frequency coverage areas, the low-frequency section of a TTL33A array still requires mutual coupling - with equal amplitude and phase - to achieve better directionality.

Low-frequency directionality is less dependent on the array's relative splay angles and more dependent on the number of elements of the array.

At low frequencies, the more elements in the array (the longer the array), the more directional the array becomes, providing more SPL in this range. The directional control of the array is achieved when the length of the array is similar or larger than the wavelength of the frequencies being reproduced by the array.

## OPTIMIZING THE ARRAY

Once the design (number of elements and vertical splay angles) has been designed using SHAPE DESIGNER software, you can effectively optimize the array depending on the environment and the application by driving it using different DSP presets stored onboard. Typically arrays are divided in two or three zones depending the design and size of the array. To optimize and EQ the array, different strategies are used for high frequencies (long throws and short throws) and low frequencies.

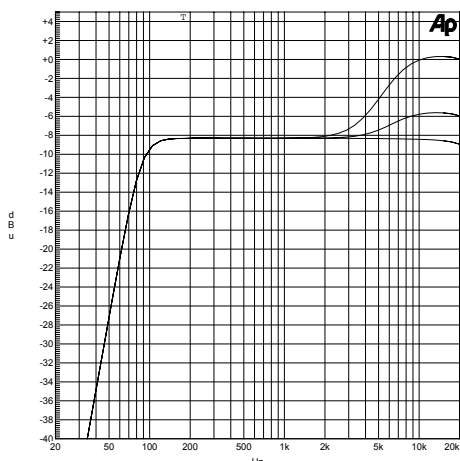

## HIGH-FREQUENCY EQUALIZATION STRATEGIES

For the far field, air absorption plays a critical role. The longer the distance, the greater the attenuation at high frequencies. In this zone, high frequencies generally need a correction to compensate for energy lost over distance; the correction needed is usually proportional to the distance and high-frequency air absorption. In the near- to mid-field, the air absorption is not nearly as critical; in this zone, high frequencies need little or no additional correction.

In the next figure is shown the equalization that corresponds to DSP settings for "near field", "mid field" and "far field":

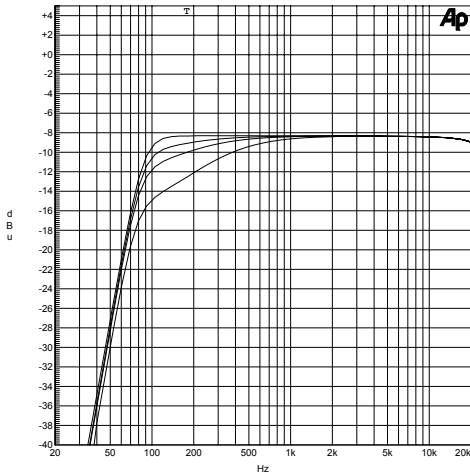

## LOW-FREQUENCY STRATEGIES

Although the array can (and usually should) be zoned for implementing different equalization curves for high frequencies, identical equalization should be maintained in all the low-frequency filters. Different low-frequency equalization settings in the same array will degrade the desired coupling effect. For the same reason, gain differences are not recommended for line arrays, since adjusting various zones with an overall amplitude control for each results in decrease of Low-frequency headroom and directionality. In any case, line arrays generally need a correction to compensate for energy sum on lows.

In the next figure is shown the equalization that corresponds to DSP settings for "cluster size set up", referring to different number of speakers from "2-3" up to "10+". Increasing the number of cabinets, response curves are decreased in order to compensate the low-frequency section mutual coupling.

## AMPLIFIER GAIN SETTINGS

In order to let the system work properly, all amplifiers must be set to the same gain. Among other things, equal amplifier gains are required to maintain array coherence throughout the venue. This does not only mean the same input sensitivity, but the same input to output voltage gain. Do not selectively boost or attenuate loudspeaker levels at the amplifiers in order to achieve consistent SPL at various distances. This is achieved by adjusting the array curvature.

## USER EQUALIZATION

Normally, the only user adjustable signal processing needed is straightforward 1/3 octave equalization. This is to correct for frequency response anomalies specific to a particular acoustical situation, type of program, or simply to satisfy a particular mixing engineer's taste in frequency balance. An important benefit of the TTL33-A/TTL31-A technology is that, by inherently maintaining the sonic character throughout the audience, user equalization will affect the frequency balance in all areas of the audience in the same way.

## PHYSICAL SET-UP

There are 8 splay angles engineered into the rigging for the TTL33-A/TTL31-As. These are set by changing the splay between the rear of the enclosures rather than the front. This means that the fronts of all enclosures are always tight-packed. The support of using RCF Shape Designer software greatly simplifies the physical set-up.

## USING SUBWOOFERS

### GENERAL CONSIDERATIONS

Although the impressive low frequency performance of TTL33-A arrays allows them to be used without subwoofers for some events, subwoofers will normally be used for live musical performances. The recommended subwoofer are TTS28-A and TTS18-A, specifically designed to complement TTL33-A line arrays.

NOTE: Bass performance is often highly program or venue-dependent, as well as subjective as to quantity and quality. For this reason the type, quantity, and disposition of subwoofers may vary considerably with the application. The quantity



recommendations below are for general purposes, providing a balanced system for most music applications. Quantities may need to be adjusted up or down for specific situations.

## TTS18-A AND TTS28-A SUBWOOFERS

TTS18-A and TTS28-A subwoofers are designed to complement the TTL33-A loudspeakers to both extend the low frequency response and provide more output for the upper low frequencies. The TTS18-A subwoofers may either be ground stacked, flown as part of a TTL33-A array, or flown separately alongside a TTL33-A array. A general recommendation is to use TTL33-A and TTS18-A in a ratio of one array module to one sub for outdoor applications and with respect of TTS28-A in a ratio of two array module to one sub for outdoor applications. For indoor applications the suggested ratio is a half number of subs.

### Subwoofer time alignment

A correct time alignment of ground stacked subwoofers to the main flown array is necessary. The signal arrival at the FoH position should be used as the reference for time alignment.

The delay time value  $\Delta t$  is equivalent to the physical offset  $\Delta x$  divided by the speed of sound (i.e. 343 m/s)

$$\Delta t = \frac{\Delta x}{v_{\text{sound}}}$$

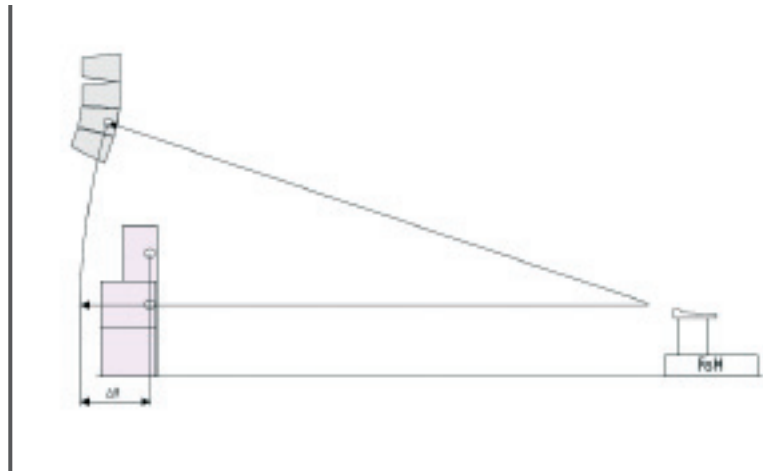

# 7.

## MAINTENANCE

### PARTS INSPECTION CHECK LIST



#### WARNING

Always check and inspect regularly and before the use all the parts of the system that are used for rigging. Always replace parts that results damaged or in not perfect conditions. DO NOT USE THE AFFECTED PARTS.

The following parts must be regularly inspected:

- **TTL33-A/TTL31-A FLY-BAR**  
(visual inspection, soldering inspection, screws securely fixed inspection, pin-holes inspection using a pin)
- **QUICK LOCK PINS**  
(visual inspection, working test)
- **FRONT BARS AND FRONT METAL CORNERS**  
(visual inspection, screws securely fixed inspection, pin-holes inspection using a pin)
- **REAR BARS AND REAR METAL CORNERS**  
(visual inspection, screws securely fixed inspection, pin-holes inspection using a pin)
- **WOODEN CABINET**  
(cabinet integrity visual inspection, metal corners securely fixed inspection, general integrity inspection)

# 8.

## TECHNICAL SPECIFICATIONS

### TTL55-A ACOUSTICAL

Operating frequ. range	50 - 20.000 Hz
Max SPL	143 dB
Horizontal Coverage	90°
Vertical Coverage	max 7°
Crossover points	20 Hz, 1.300 Hz

### TRANSDUCERS

Low frequency	2 x 12" midbass neo, 100 mm voice coil
Mid frequency	1 x 10" midrange neo, 89 mm voice coil
High frequency	3 x 1.5" compression driver

### AMPLIFIER

Total power supply switching	3500 Watt
Low section	D / 2 x 1000 Watt
Mid section	D / 1000 Watt
High section	D / 500 Watt

### CONNECTIONS

Signal Input/Output	XLR Ethercon
Power Input/Output	Powercon

### CONFIGURATION CONTROLS

Array size control (4/6-7/9-10/12-13/20)  
Distance control (Near field - Mid field - Mid far - Far)

### DSP PROCESSOR

- 32 bits, 96 KHz sampling, floating point
- 3 way equalisation, crossover filtering, fast limiter, RMS limiter.
- array size configuration set-up
- distance correction set-up
- low filtering set-up

### MECHANICAL

Size	1020 x 380 x 550 mm
Weight	67 Kg

### TTL33-A ACOUSTICAL

Operating frequ. range	60 - 20.000 Hz
Max SPL	135 dB
Horizontal Coverage	100°
Vertical Coverage	15°, depending on configuration
Crossover points	400 Hz, 1.800 Hz

### TRANSDUCERS

Low frequency	2 x 8" midbass neo, 64 mm voice coil
Mid frequency	1 x 8" midrange neo, 64 mm voice coil
High frequency	3 x 1" compression driver

### AMPLIFIER

Total power supply switching	750 Watt
Low section	D / 500 Watt
Mid section	D / 500 Watt
High section	D / 250 Watt

### CONNECTIONS

Signal Input/Output	XLR male/female
Power Input/Output	Powercon male/female

### CONFIGURATION CONTROLS

Array size control (2/3-4/6-7/9-10/16)  
Distance control (Near - Mid - Long)  
Full range / high pass  
Volume Control

### DSP PROCESSOR

- 32 bits, 96 KHz sampling, floating point
- 3 way equalisation, crossover filtering, fast limiter, RMS limiter.
- array size configuration set-up
- distance correction set-up
- low filtering set-up

### MECHANICAL

Size	760 x 300 x 450 mm
Weight	33 Kg

## **TTL31-A**

### **ACOUSTICAL**

Operating frequ. range	60 - 20.000 Hz
Max SPL	132 dB
Horizontal Coverage	100°
Vertical Coverage	15°, depending on configuration
Crossover points	1.600 Hz

### **TRANSDUCERS**

Low frequency	8" neo, 64 mm voice coil
Mid frequency	x
High frequency	3 x 1.0" neo, 37 mm voice coil

### **AMPLIFIER**

Total power supply switching	750 Watt
Low section	D / 500 Watt
Mid section	x
High section	D / 250 Watt

### **CONNECTIONS**

Signal Input/Output	XLR male/female
Power Input/Output	Powercon male/female

### **CONFIGURATION CONTROLS**

Array size control (2/3-4/6-7/9-10/16)  
Distance control (Near - Mid - Long)  
Full range / high pass  
Volume Control

### **DSP PROCESSOR**

- 32 bits, 96 KHz sampling, floating point
- 3 way equalisation, crossover filtering, fast limiter, RMS limiter.
- array size configuration set-up
- distance correction set-up
- low filtering set-up

### **MECHANICAL**

Size	300 x 538 x 450 mm
Weight	22,5 Kg









[www.rcfaudio.com](http://www.rcfaudio.com)

**RCF SpA:** Via Raffaello, 13 - 42124 Reggio Emilia > Italy  
tel. +39 0522 274411 - fax +39 0522 274484 - e-mail: [rcfservice@rcf.it](mailto:rcfservice@rcf.it)

10307091 Rev G