

Model: LMB-series

# Lowell Mobile Base

## Description:

The LMB mobile base is designed to mount inside the rack frame to provide the benefits of mobility and a floor positioned flush to the bottom rack space. This model is often specified to support extra-heavy equipment that is mounted in the lowest rack position. Construction is 14-gauge steel with a durable wrinkle black powder epoxy finish. To facilitate cable access, there is a center opening in the bottom and cable pass-through openings on the sides that match up to side openings on matching gangable racks (LGR-series). The base features 4 non-locking, heavy-duty swivel casters, which are positioned inside the platform. When installed in a rack, the increase in overall height is only 1.25". The casters have a load rating of 350 lbs. each (1,400 lbs. total).

Note: The mobile base is not for use with seismic-certified racks.



## Features:

- Rugged, fully-welded construction.
- Easy cable access through center opening.
- Includes hardware for bolt-on installation.
- Available in four depths: 27", 32", 36", 42"
- For use with 19" wide racks (LER, LER-F and LGR-series).
- Base increases rack height 1.25".
- Includes 4 non-locking (3") swivel casters with a load rating of 350 lbs. each.

## A & E Specifications:

The mobile base for the rack shall be Lowell Model \_\_\_\_\_, which shall be of an inner platform design that mounts inside the rack frame to add the benefits of mobility and a floor positioned flush to the bottom rack space. Construction shall be 14-gauge welded steel with a black wrinkle powder epoxy finish. The heavy-duty, 3" non-locking swivel casters shall be positioned inside the platform so that, when installed, the increase in overall rack height shall be 1.25". The casters shall have a load rating of 350 lbs. each (1,400 lbs. total). The mobile base shall facilitate cable access through a center opening. The base shall have side cable access via cable pass-through openings that align with the side openings on matching gangable racks (LGR-series). Mounting hardware to attach the base to the rack shall be supplied with the base.

Model No.	Description	Former No.	Overall Size (W x D x H)	Inside Size (W x D)	Center Opening (W x D)	Weight (lbs.)
LMB-27	Mobile Base (for 27"D rack)	MB227	22.81" x 26.75" x 3"	19.81" x 22.75"	12.97" x 11.00"	28
LMB-32	Mobile Base (for 32"D rack)	MB232	22.81" x 31.75" x 3"	19.81" x 27.75"	12.97" x 16.00"	31
LMB-36	Mobile Base (for 36"D rack)	MB236	22.81" x 35.75" x 3"	19.81" x 31.75"	12.97" x 20.00"	38
LMB-42	Mobile Base (for 42"D rack)	-----	22.81" x 41.75" x 3"	19.81" x 37.75"	12.97" x 26.00"	37

# Lowell Mobile Base

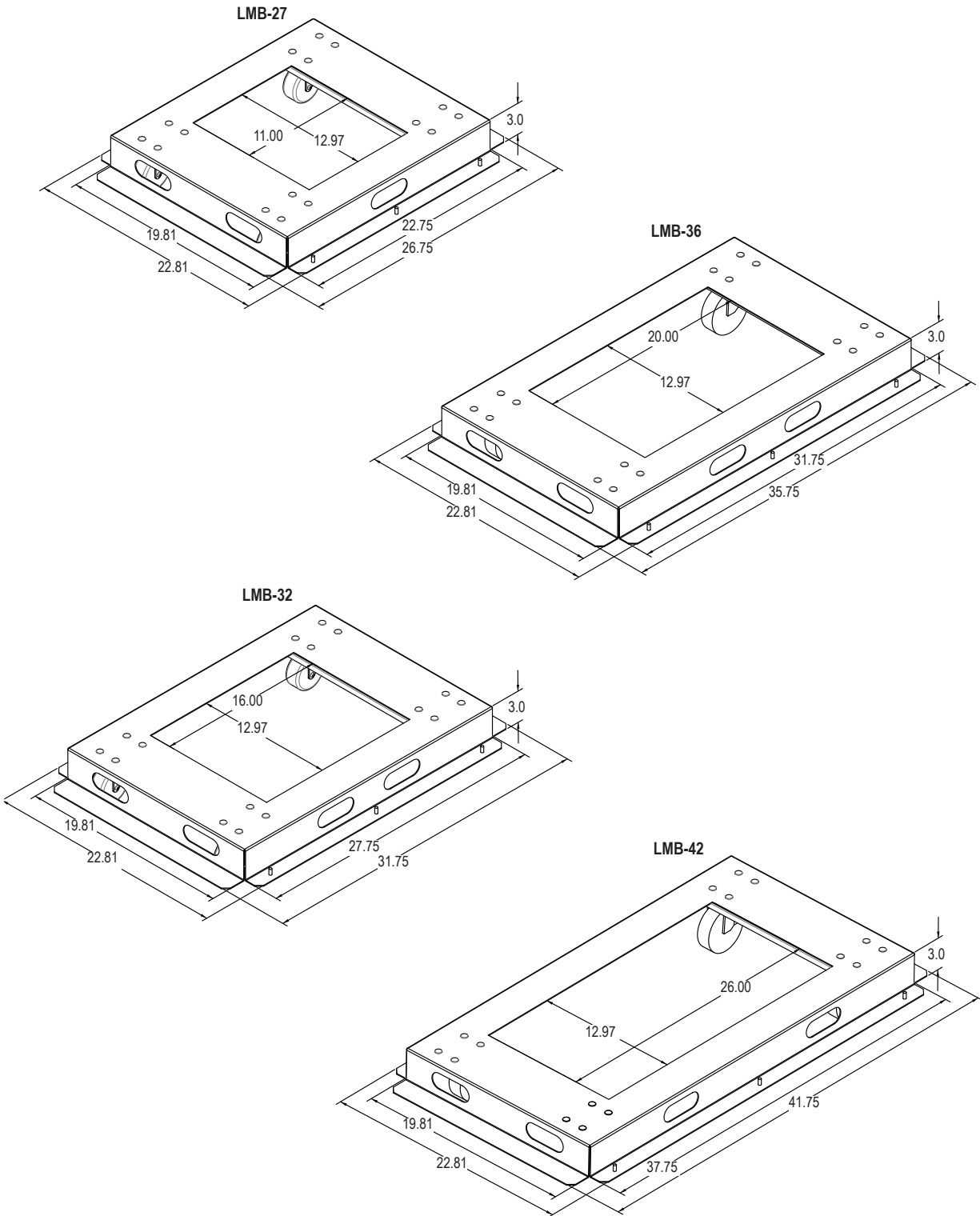

All measurements are inches.