

Model: FS-series

Flat Ship Wall Shelf

Description:

The fully-assembled FS wall shelf ships flat in a compact carton for economical, convenient warehousing. To mount, simply rotate the rear panel 90-degrees so the front panel flanges insert into the rear panel cutouts. The shelf provides secure support for up to 100 lbs. of equipment when properly mounted to a wall. Key-hole mounting slots are on 16" stud centers and are slotted so the shelf can be inverted to meet application requirements.

The top of the shelf has two oblong cutouts (2.5"L x 1.25"W) for cable drop-down. The wall side has a large center opening for wire access, while allowing the shelf to be placed over existing outlets and fixtures. Side openings are spaced for single gang stud-mounted conduit boxes. There are cable lacing points and pre-punched mounting holes between center and side openings for field versatility. The shelf also features a front retaining lip that is flanged for strength. Assembly is 16-gauge US steel with a durable black powder epoxy finish.

Features:

- Fully assembled wall shelf ships flat and folds out to serviceable position.
- Mounts on 16" stud centers. Center opening allows wire access and placement over existing outlets and fixtures.
- Side openings are spaced for single gang, stud-mounted conduit boxes.
- Pre-punched cable lacing and accessory mounting holes provide field versatility.
- Supports up to 100 lbs.
- Available in 14", 16" and 20" depths
- Made in the USA with 100% US steel

A & E Specifications:

The wall shelf shall be Lowell Model _____. The shelf shall require no field assembly and shall measure 8.19"H x 18.22"W x _____"D in open/service position and fold flat for shipping or storage. Wire management shall be provided on the top surface using two oblong cutouts measuring 2.5"L x 1.25"W. Top shall also include a retaining lip. Shelf shall support up to 100 lbs. when properly mounted (mounting hardware by others). Keyhole mounting slots on 16" centers are provided in the rear panel. Rear panel shall also have a large center opening for mounting the shelf over existing fixtures and side openings to accommodate single-gang stud-mounted conduit boxes. Rear panel shall be pre-punched for mounting accessories and lacing cable. Shelf shall be finished in black powder epoxy.



The FS wall shelf ships—fully assembled—in a folded position.



It can be installed in either direction.



Model No.	Description	Width	A Depth	Height	Load Capacity
FS18-14	Lowell Flat Ship Wall Shelf	18.22"	14"	8.19"	100 lbs.
FS18-16	Lowell Flat Ship Wall Shelf	18.22"	16"	8.19"	100 lbs.
FS18-20	Lowell Flat Ship Wall Shelf	18.22"	20"	8.19"	100 lbs.

One rack unit (RU or U) = 1.75"

Spec. No. 1153
(rev. 07.21.11)
pg. 1 of 2

©2011 Lowell Manufacturing Company, 100 Ingram Dr., Pacific MO 63069. Phone-800.325.9660 Fax-636.257.6606. Lowell makes every effort to provide accurate information while reserving the right to change specifications and/or improve manufacturing methods without notification. (lowellmfg.com)



Model: FS-series

Flat Ship Wall Shelf

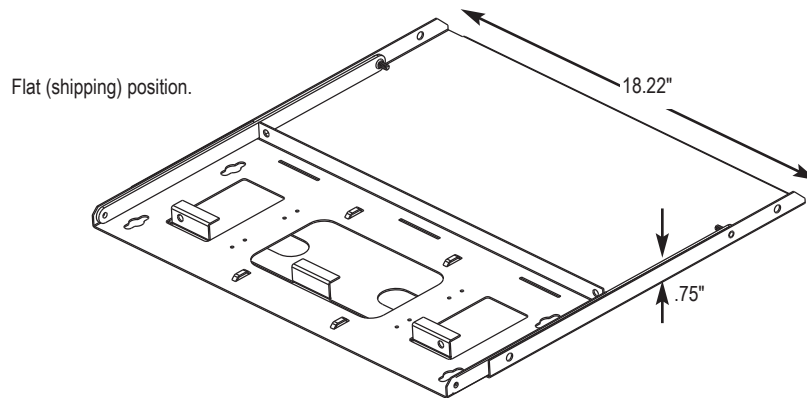
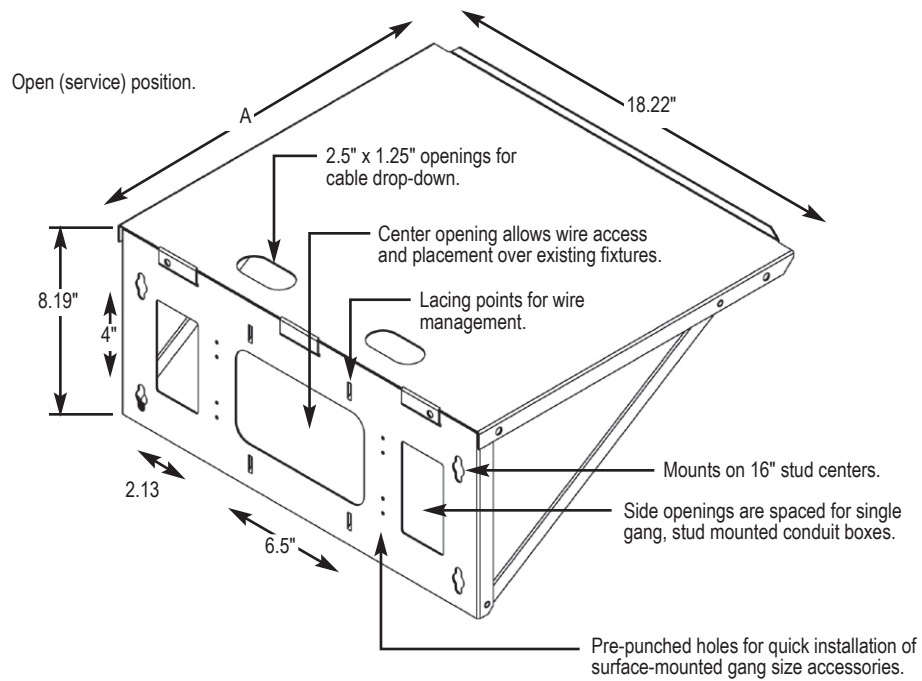

Measurements are shown in inches.