

15A AC Power Strip with Attached (Fixed) Cord

Description:

These 15A AC power strips provide convenient access to power in racks and cabinets. The UL Listed devices feature single outlets spaced to accept some large power supplies (wall warts) and terminate to an attached cord with NEMA 5-15P molded plug. Includes common mode transient voltage surge suppression (UL 1449-3 Listed) with an LED indicator and a 15A circuit breaker. Installs to rack with mounting clip and screw. Black chassis. Imported.



Features:

- Light colored single outlets provide high visibility inside dark cabinets and are spaced to allow room for some large “wall-wart” power supplies.
- Attached cord (6-ft. or 12-ft., depending on model) with NEMA 5-15P molded plug.
- Common mode transient voltage surge suppression (UL 1449-3 Listed) with LED indicator and 15A circuit breaker:
 - Suppressed voltage rating: 400V
 - Energy dissipation: 450 Joules (8 x 20us waveform)
 - Lines protected: L-G, L-N, N-G
 - Maximum surge: 6000V
 - Maximum peak current: 6500 Amperes (L-G, L-N, N-G)
 - Response time: less than one (1) nanosecond
 - Noise filtering: EMI / RFI
 - LED is on when protection is active
- Bag of cable ties (to secure power supplies) and mounting clip/screw
- Model ACS-1506: features 6 (15A) single outlets on 20”L chassis with 6-ft. fixed cord.
- Model ACS-1512: features 12 (15A) single outlets on 32”L chassis with 12-ft. fixed cord.
- Model ACS-1524: features 24 (15A) single outlets on 60”L chassis with 12-ft. fixed cord.

A & E Specifications:

The UL Listed power strip shall be Lowell Model _____. Power rating shall be 15A with circuit breaker protection and an LED indicator that is lit when protection is active. The power strip shall have a suppressed voltage rating of 400V with maximum surge at 6000V and 6500 Amperes maximum peak current. Power strip shall include _____ outlets spaced to accept power supplies. It shall be terminated with a _____ foot cord and molded plug. It shall install to adjustable or fixed rail racks with a mounting clip and screw.

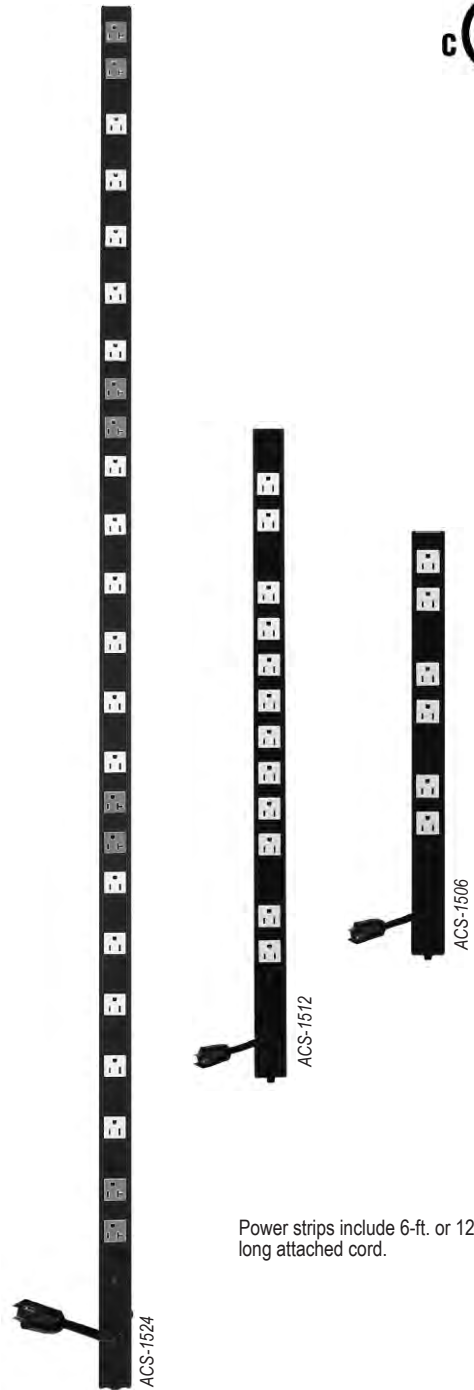

Power strips include 6-ft. or 12-ft. long attached cord.

Model No.	Description	Power	Outlets	NRTL	Surge Suppression	Chassis Size
ACS-1506	AC Power Strip with fixed (attached) cord	15A	6 single	UL	Yes	20" x 1.625" x 1.375"
ACS-1512	AC Power Strip with fixed (attached) cord	15A	12 single	UL	Yes	32" x 1.625" x 1.375"
ACS-1524	AC Power Strip with fixed (attached) cord	15A	24 single	UL	Yes	60" x 1.625" x 1.375"

15A AC Power Strip with Attached (Fixed) Cord

Front Panel Layout

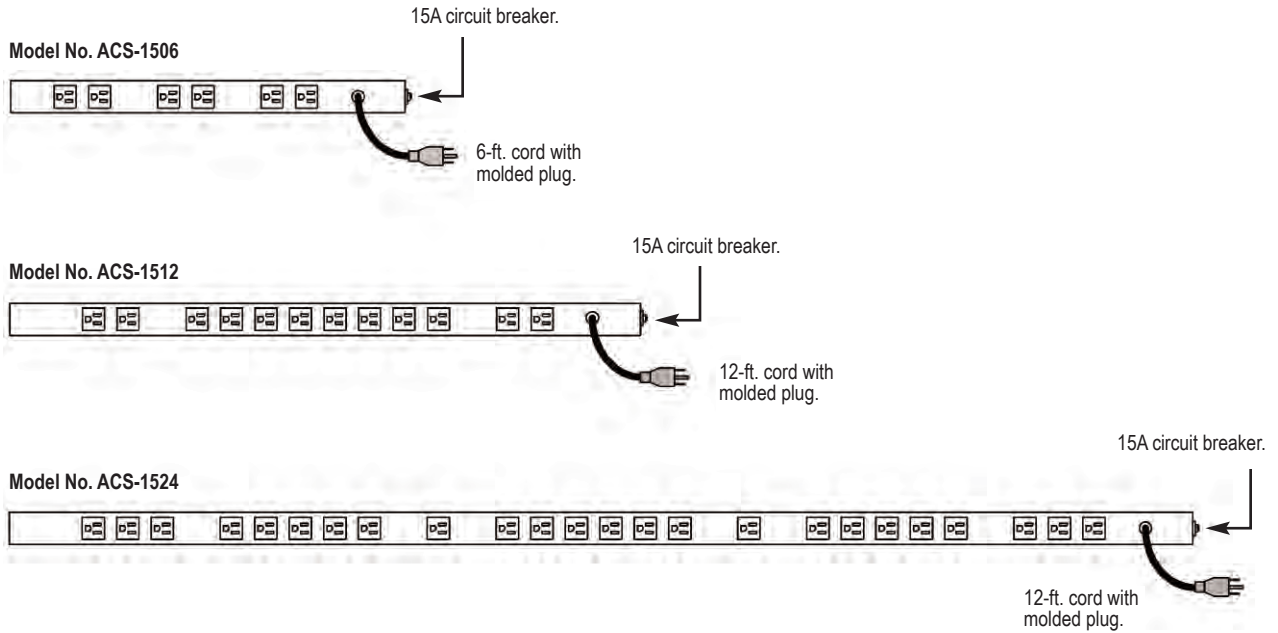

Features

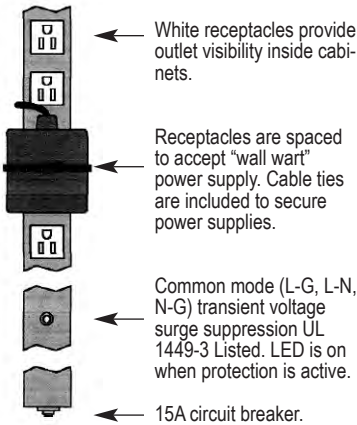

Installation: adjustable mounting rails

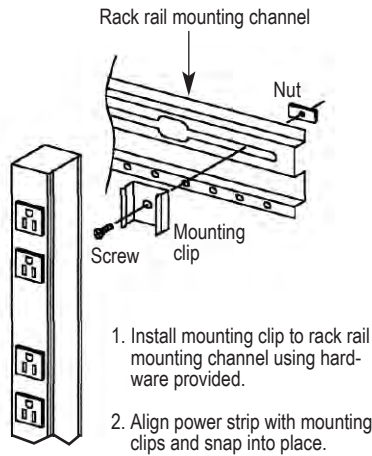

Installation: fixed mounting rails

