

# 8" Dual Cone Speaker (optional transformer)

## Description

Lowell speaker Model 810 is a step up in full range performance from the commercial industry standard 8-in. (5 oz.) speaker. It features a 10 oz. magnet for higher power handling and greater sensitivity and includes a 1-in. copper voice coil, dual cone design, and plated steel basket. It provides solid performance and good value in almost any basic paging or background music system. The speaker is available with a selection of factory-wired transformers and will fit standard 8-in. ceiling grilles and backboxes. The dual cone speaker assembly employs a highly efficient magnetic structure energized by a 10 oz. ceramic magnet. The use of a 3/4 in. hard fiber whizzer cone mechanically coupled to the 1-in. voice coil provides extended high frequency response with fine clarity, while the molded fibre cone enhances mid- and low-range frequency performance.

## Features

- 15W 8" (10 oz.) speaker
- Dual cone speaker provides clear and accurate reproduction of music and voice communications.
- Frame is stamped 20-gauge steel with zinc-plated finish to prevent corrosion.
- Compatible with Lowell architectural grilles, backboxes, and surface baffles
- Manufactured in USA to meet or exceed all applicable EIA standards.
- Optional factory-wired transformer:
  - TLM-572: taps at 0.25, 0.5, 1, 2, 5W (70/25V)
  - TLM-470: taps at 0.5, 1, 2, 4W (70V)
  - TLM-870: taps at 1, 2, 4, 8W (70V)



Model No. 810



Model No. 810-T72



Model No. 810-T470



Model No. 810-T870

## A&E Specifications

The dual cone 8-inch speaker shall be Lowell Model \_\_\_\_\_. It shall be of the permanent magnet type having a seamless molded fiber cone with a hard fiber whizzer cone mechanically coupled to the voice coil for extended high frequency response. It shall be capable of producing a uniform audible frequency response over the range of 47Hz-20kHz+6dB with a dispersion angle of 120-degrees @ 2000Hz-6dB. The average sensitivity shall measure 95dB (SPL at 1W/1M). Rated power handling capacity shall be 15 watts RMS. The voice coil shall have a 1-in. dia. and shall operate in a magnetic field derived from a strontium ferrite (ceramic) magnet having a nominal weight of 10 oz. The voice coil impedance shall be 8 ohms. The speaker shall have a round, structurally reinforced stamped 20-ga. steel frame to maintain precise mechanical alignment and shall provide facilities to mount a transformer. The speaker shall have an overall dia. of 8.062-in. with eight obround holes equally spaced at 45-degrees on a 7.625-in. dia. mounting bolt circle. The overall depth shall not exceed 2.84-in. (not including transformer). External metal parts shall be zinc-plated to resist rust and corrosion.

**For 25 or 70.7 volt distributed systems:** The speaker shall be equipped with a transformer, factory-mounted and wired. The transformer's primary voltage shall be \_\_\_\_ and shall provide selectable power taps of \_\_\_\_ watts. The transformer frequency response shall be from \_\_\_\_ to \_\_\_\_Hz +\_\_\_\_dB, with max. insertion loss of \_\_\_\_dB.

Model No.	Mounted Xfmr	Assembly Depth*	Assembly Weight	Xfmr Power Rating	Xfmr Primary Voltage	Xfmr Primary Taps	Xfmr Response	Xfmr Insertion Loss
810	---	---	---	---	---	---	---	---
810-T72	TLM-572	2.84"	2.4 lb	5 Watts	25/70V	0.25, 0.5, 1, 2, 5W	40Hz - 20kHz +1dB	<0.5dB
810-T470	TLM-470	2.84"	2.6 lb	4 Watts	70V	.5, 1, 2, 4W	60Hz - 15kHz +1dB	0.8dB
810-T870	TLM-870	2.84"	2.9 lb	8 Watts	70V	1, 2, 4, 8W	50Hz - 15kHz +1dB	0.8dB

\* Minimum depth required for the speaker transformer assembly to be rear mounted in an enclosure.

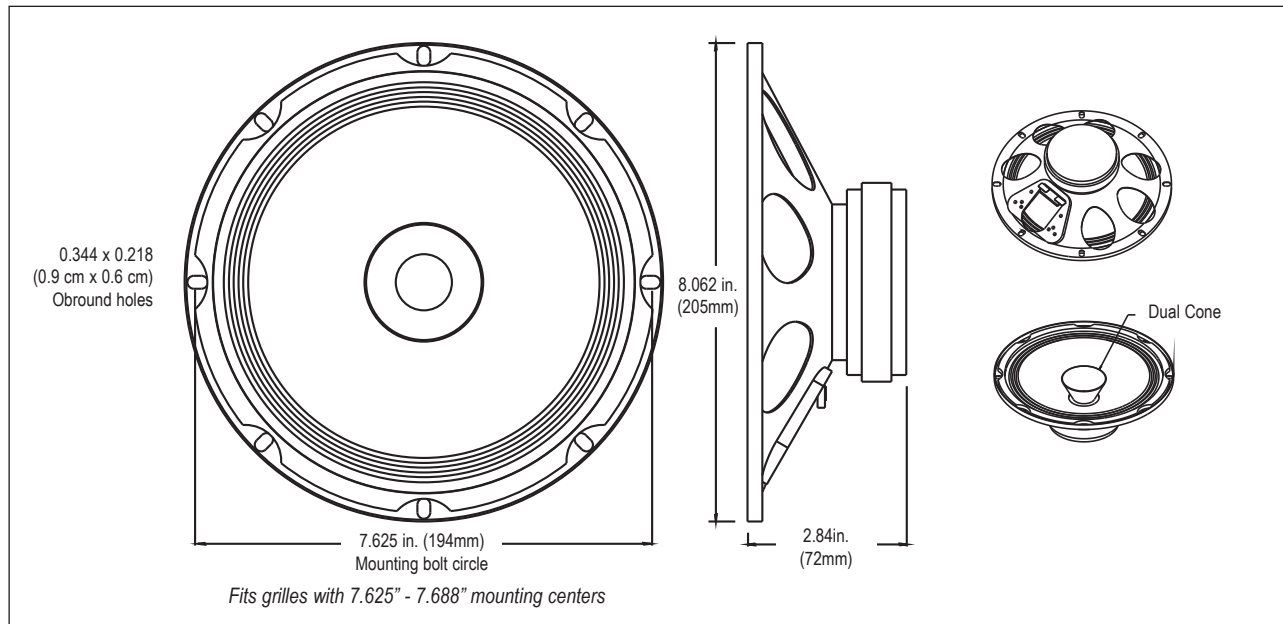

### Driver (only) Specifications:

#### PERFORMANCE

Power Handling	15 watts RMS (nominal) measured per EIA Standard RS-426B
Sensitivity	95dB Average SPL (measured 2.83V @ 1m) 106.8 dB Maximum SPL (calculated based on power rating and measured sensitivity)
Impedance	8 ohms (nominal), 8.8 ohms @260Hz (minimum)
Frequency Response	47Hz-20kHz (+6dB)
Dispersion Angle	120° conical @ 2000Hz octave (-6dB)

#### PHYSICAL - WOOFER

Magnet Weight, Material	10oz. (264g), strontium ferrite ceramic
Voice Coil Diameter, Material	1 inch (26mm), copper wire
Cone Material	Dual cone paper with self edge surround
Terminals	Quick disconnect type - spade lugs

#### MECHANICAL

Basket	20 gauge stamped steel with zinc plating
Outside Diameter	8.062 inch (205mm)
Mounting Bolt Circle	7.625 inch (194mm) with 8 obround holes equally spaced at 45 degrees.
Cutout Diameter	7.15 inch (182mm)
Mounting Depth	2.84 inch (72mm)
Net Weight	2.0 lbs. (0.91kg)

#### THIELE-SMALL PARAMETERS

Pe.....15W	Qts.....1.05	BL.....5.0Tm	Sd.....33.6 in <sup>2</sup> , 214cm <sup>2</sup>
Fs.....88Hz	Qes.....1.25	Efficiency, η.....1.5%	Mms.....7.6g
Xmax.....0.05 in., 1.4mm	Qms.....6.4	Vas.....29 liters, 1770 cu.in.	Cms.....0.44mm/N
Re.....7.6W			

#### Optional Accessories (order separately):

Recessed Backbox (for screw-mount grille)		Recessed Backbox (for screw-mount or torsion grille)	
CP84	11.938Dia x 4.063D, Ext. lip for sheetrock	XCP84	10.063Dia x 4.063D, flat flange for tile ceiling
CP87	11.938Dia x 6.687D, Ext. lip for sheetrock + batting	XCP87	10.063Dia x 6.687D, flat flange for tile ceiling + batting
CP810	11.938Dia x 10.063D, Ext. lip for sheetrock + batting	XCP810	10.063Dia x 10.063D, flat flange for tile ceiling + batting
DX58	.5cuft 11.938Dia x 8D, Ext. lip for sheetrock + batting		
DX108	1cuft 15Dia x 10.125D, Ext. lip for sheetrock + batting		
IX810	10.063Dia x 10.063D Direct mnt 8in spkr-no load on grille+ batting		
DX198	1cuft 15Sq x 8D, Ext. lip for sheetrock + batting		
P68X	10Sq x 4D		
P68X-6	10Sq x 6D		
		Surface-mount Wall Baffle	
		SL8-W	Sloped front, wood with cloth grille 10.5H x 9.438W

**Scope of Lowell Performance & Power Tests:**

Lowell drivers and loudspeaker systems are tested to provide specifiers and contractors with data that reflects the performance of production products. Testing equipment includes the GoldLine TEF-20 analyzer (for performance measurements) and the LinearX LMS measurement system (for Thiele-Small Parameters).

**Power Handling** capability is tested based on EIA Standard RS-426B.

**Frequency Response data** is provided which is the measured frequency response range (defined by + 6dB) which is useful in predictive engineering calculations.

**Sensitivity (SPL) data** is presented in two ways: Log Average SPL is a computer calculated log average of the SPL measured at 1 meter with 1 watt input over the stated frequency response range. Maximum SPL is calculated based on the measured log average SPL and the 8-ohm power rating of the speaker. Maximum SPL for loudspeakers which do not include an 8 ohm input, is calculated based on the measured log average SPL and the highest transformer power tap.

**Dispersion Angle** is defined as the angle of coverage that is no more than 6dB down from the on-axis value averaged over the 2000Hz octave band. Since speech intelligibility is very dependent upon the 2000Hz octave, this specification is quite useful in designing speech reinforcement systems that provide even coverage and speech intelligibility.

**Thiele-Small Parameters** for raw drivers are measured using the LinearX LMS measurement system. These parameters are useful in determining the optimum type and size of enclosure for a specific driver.

**Impedance data** is presented in three ways: Nominal Impedance is the generally accepted impedance for use in making comparisons with competitive products, the Impedance Curve is a graphical representation of the impedance that is measured in the lab and gives the impedance of the device over the audio frequency range. Minimum Impedance is the lowest impedance measurement at a frequency within the specified frequency response range of the speaker. If a line matching transformer is included in the speaker assembly, relative impedance curves of the primary windings of the transformer when loaded by the driver may be shown.

**Polar data** is presented for the averaged one octave band surrounding the center frequencies of 1000Hz, 2000Hz, 4000Hz, and 8000Hz. Radial polar response curves show the relative change in sound pressure level as one moves from directly on-axis to an increasingly off-axis listening position. Since coaxial speaker drivers are symmetrical in the vertical and horizontal directions, only one set of polar plots will be presented for coaxial drivers and speaker systems incorporating coaxial drivers. Vertical and horizontal polar plots will be presented for two-way speaker systems that incorporate separate low frequency and high frequency drivers.

**SPL vs. Frequency (1W / 1M, On Axis)**

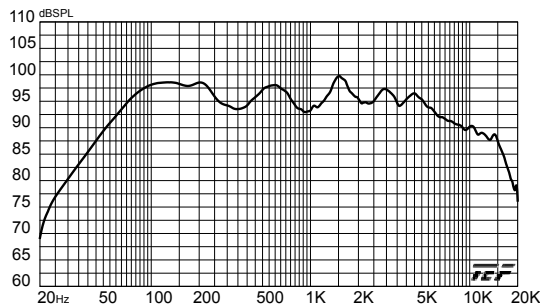

**SPL vs. Frequency (1W / 1M, Off Axis)**

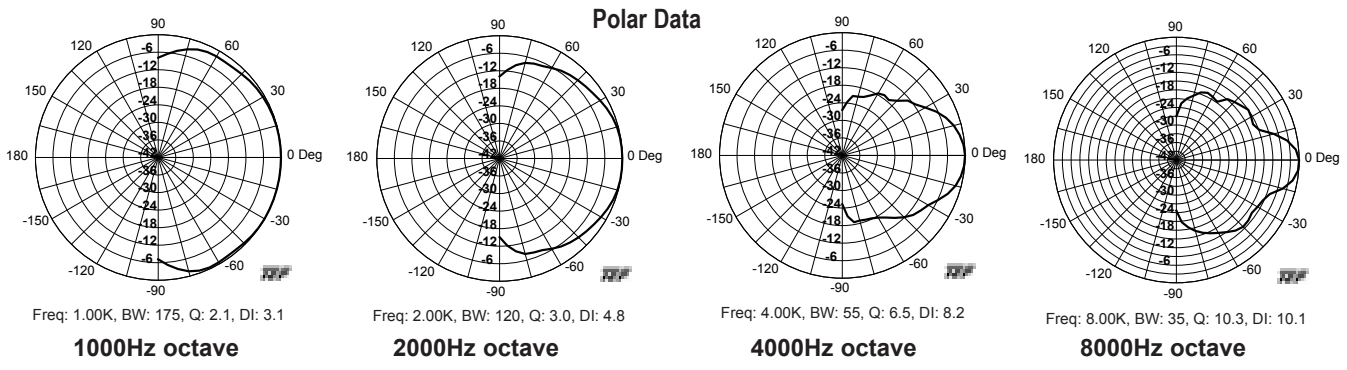
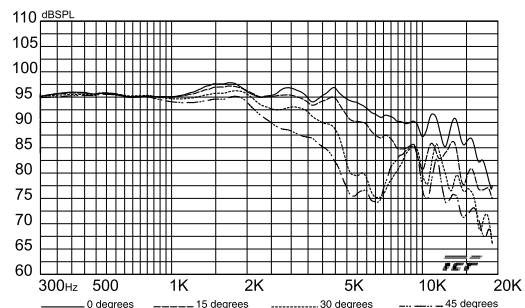

**Impedance**

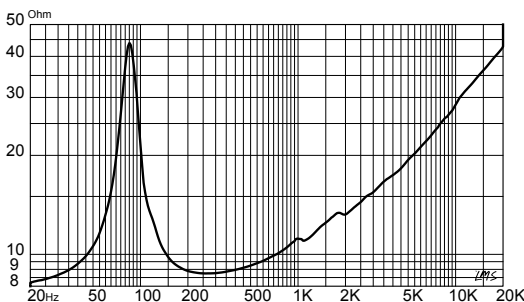

**Impulse**

