

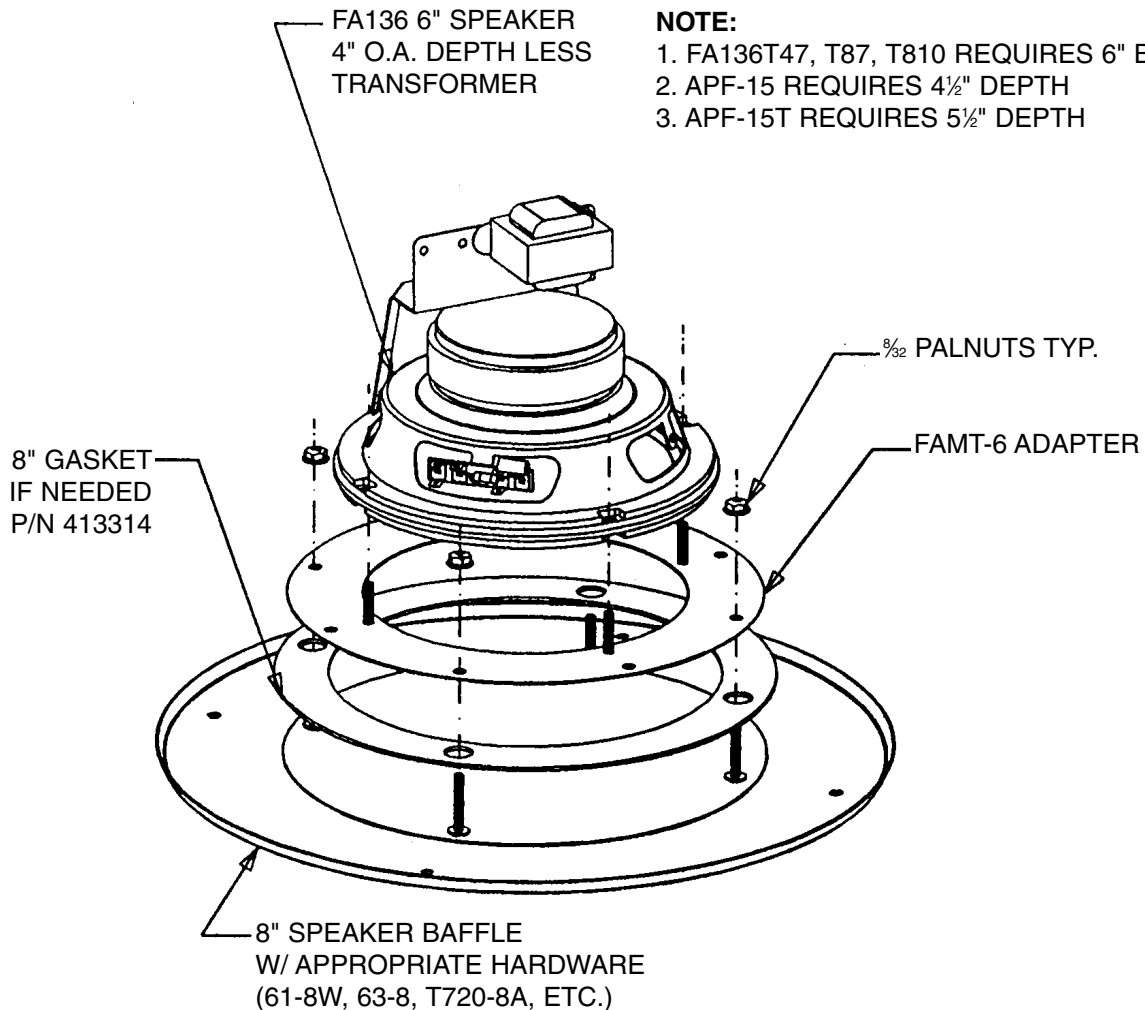

FAMT-6 INSTRUCTION SHEET CONTENTS:

1. FAMT-6 ADAPTER RING 8" TO 6" P/N377893
2. (4) PALNUTS P/N 112992
3. GASKET P/N413314



Specifications are subject to change without notice



**Atlas
Sound**

AtlasSound.com

1601 JACK MCKAY BOULEVARD ENNIS, TEXAS 75119 U.S.A. • TELEPHONE: (800) 876-3332 • FAX: (800) 765-3435

©2004 ATLAS SOUND LP

Printed in U.S.A.

00404

ATS001252 RevC 4/04

385525