

LMM1S

Mic/Line Input Module

Features

- Line mode for high impedance input
- MIC Mode for low impedance input
- Electronically balanced input
- Gain/Trim control with Gain range switch
- Bass and treble
- 24V Phantom power
- Audio Gating
- Gating with threshold and duration adjustments
- Fade back from mute
- 4 levels of available priority
- Can be muted from higher priority modules
- Can mute lower priority modules
- Removeable screw terminal input

1. Gate - Threshold (Thresh)

Controls the amount of input signal level necessary to turn the module's signal output on and mute lower priority modules. Clockwise rotation increases the necessary input signal level required to produce audio output and mute lower priority modules.

2. Gate - Duration (Dur)

Controls the amount of time the signal output and priority muting of the module remains applied to the main unit's buses after the input signal falls below the required minimum signal level (set by the threshold control).

3. Treble (Treb)

The Treble control provides +/- 10 dB at 10 kHz. Clockwise rotation provides boost; counterclockwise rotation provides cut. Center position provides no effect.

4. Bass

The Bass control provides +/- 10 dB at 100 Hz. Clockwise rotation provides boost; counterclockwise rotation provides cut. Center position provides no effect.

5. Gain

Provides control over the level of input signal that can be applied to the internal signal buses of the main unit. Balances the input levels of various devices so that the main unit controls can be set to relatively uniform or optimum levels. 18-60 dB Gain range in MIC position, -2 to 40 dB in Line position.

6. MIC/Line In

MIC/Line level input on removeable screw terminal strip. Electronically balanced input.

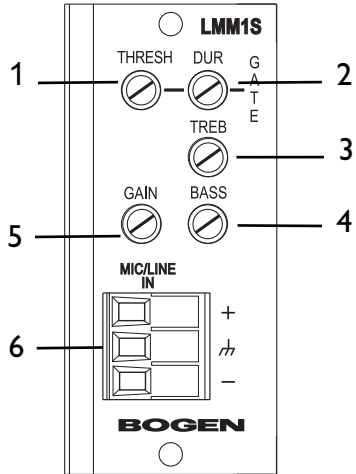

WARNING:
Turn off power to unit and make all jumper selections before installing module in unit.

Jumper Selections

Priority Level*

This module can respond to 4 different levels of priority. Priority 1 is the highest priority. It mutes modules with lower priorities and is never muted. Priority 2 can be muted by Priority 1 modules and can mute modules set for Priority Level 3 or 4. Priority 3 can be muted by either Priority 1 or 2 modules and can mute Priority 4 modules. Priority 4 modules are muted by all higher priority modules. Remove all jumpers for “no mute” setting.

*The number of priority levels available is determined by the equipment the modules are used in.

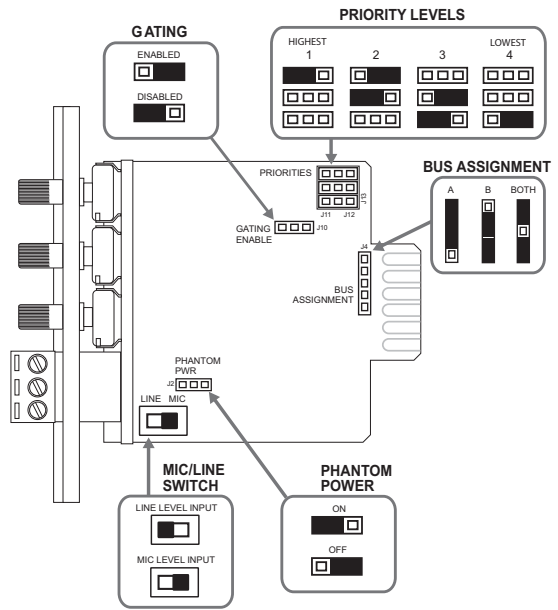

Gating

Gating (turning off) of the module’s output when insufficient audio is present at the input can be disabled. Detection of audio for the purpose of muting lower priority modules is always active regardless of this jumper setting.

Phantom Power

24V Phantom power can be supplied to condenser microphones when jumper is set to ON position. Leave OFF for dynamic mics.

Bus Assignment

This module can be set to operate so that the mono signal can be sent to the main unit’s A bus, B bus, or both buses.

MIC/LINE Switch

Sets input gain range for the intended input device. MIC gain range 18 – 60 dB, LINE gain range -2 – 40 dB.

Module Installation

1. Turn off all power to the unit.
2. Make all necessary jumper selections.
3. Position module in front of any desired module bay opening, making sure that the module is right-side up.
4. Slide module onto card guide rails. Make sure that both the top and bottom guides are engaged.
5. Push the module in to the bay until the faceplate contacts the unit’s chassis.
6. Use the two screws included to secure the module to the unit.

Input Wiring

Balanced Connection

Use this wiring when the source equipment supplies a balanced, 3-wire output signal.

Connect the shield wire of the source signal to the "G" terminal of the input. If the "+" signal lead of the source can be identified, connect it to the plus "+" terminal of the input. If the source lead polarity cannot be identified,

connect either of the hot leads to the plus "+" terminal. Connect the remaining lead to the minus "-" terminal of the input.

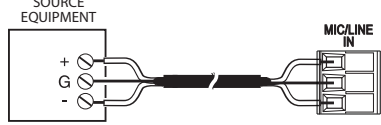

Note: If polarity of the output signal versus the input signal is important, it may be necessary to reverse input lead connections.

Unbalanced Connection

When the source device provides only an unbalanced output (signal and ground), the input module should be wired with the "-" input shorted to ground (G). The unbalanced signal's shield wire is connected to the input module's ground and the signal hot wire is connected to the "+" terminal. Since unbalanced connections do not provide the same amount of noise immunity that a balanced connection does, the connection distances should be made as short as possible.

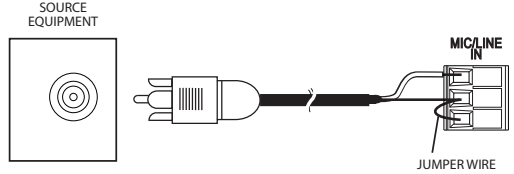

Block Diagram

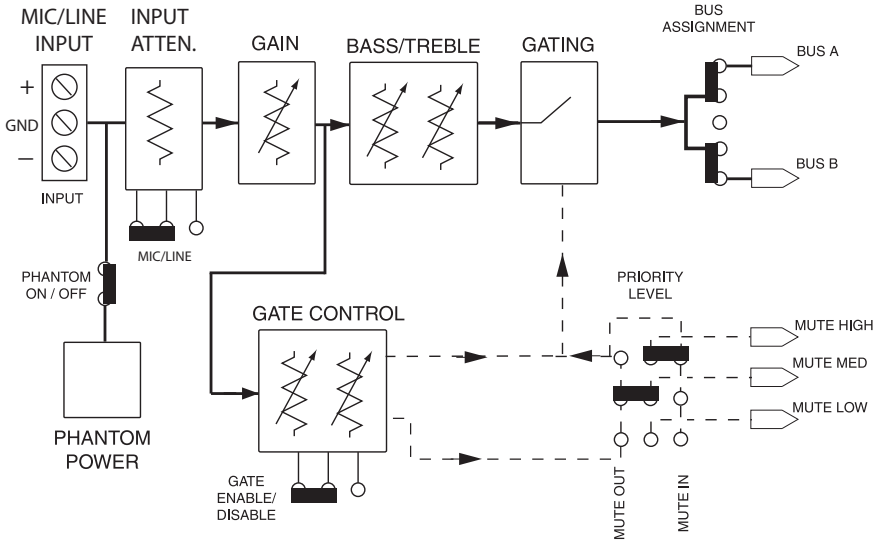

BOGEN[®]
COMMUNICATIONS, INC.

50 Spring Street, Ramsey, NJ 07446, U.S.A.

201-934-8500; Fax: 201-934-9832

www.bogen.com