

PERFORMANCE, PATTERN CONTROL AND PRICE.

in.LINE

← INSTALLATION GRADE LINE ARRAY →

The **ONLY** High Performance Line Array Technology Specifically **ENGINEERED** and **PRICED** for Installation.

CUSTOM-BUILD COVERAGE

The **IN.LINE™** series is the only line array technology to offer sound designers the ability to tailor the horizontal coverage to fit the unique dimensions of the installation. Full range **IN.LINE™** modules are available in three horizontal coverage patterns; 60°, 90° and 120°... yet are otherwise identical. These modules can be "mixed and

matched", within the same line array column, allowing designers to reap the benefits of a line array solution, while retaining the ability to configure horizontal coverage. This simple illustration shows how seven **IN.LINE™** modules could completely cover a rectangular listening space, while keeping excess acoustic energy off the walls.

OVERHEAD VIEW



IN.LINE SERIES
N60 60° FULL RANGE **N90** 90° FULL RANGE **N120** 120° FULL RANGE **NS1** LF MODULE



also available in black

APPLICATIONS

IN.LINE™ arrays have been successfully deployed in a wide range of high fidelity, high output foreground applications... including houses of worship, night clubs, live performance spaces, auditoriums, sports venue and more.

EXCEPTIONAL CLARITY

All three full range **IN.LINE™** modules feature **FREQUENCY DEPENDENT ADAPTIVE STEERING™** technology, a mechanical crossover function built into the cone drivers themselves, which contributes to the array being perceived as a single acoustic source. This improves cell-to-cell summation, boosting intelligibility and minimizing destructive lobing.

BUILT TO FLY

Designed exclusively for permanent installation only, a complete rigging hardware package is standard equipment with every **IN.LINE™** module. This simple "set it and forget it" system allows installers to set splays in a matter of minutes, while designers can choose from 0° to 10° of splay between each module when defining the vertical coverage of an array.

FACTORY DESIGN SUPPORT

The **SYSTEM DESIGN GROUP** is our in-house team of installation design specialists. Available exclusively to McCauley Sound's consultant and contractor partners, the **SDG** provides installation support, including array design, CAD file preparation, acoustic predictive modelling and more... lending the full talent of McCauley's engineering team to every installation.

BUDGET FRIENDLY

Offering a technologically superior solution is not always enough for many of today's budget-sensitive installations... **PRICE** is also a major factor. **IN.LINE™** overcomes this obstacle by offering installers the **BEST RATIO** of **PRICE TO PERFORMANCE** of any professional commercial line array.

in.LINE™

← INSTALLATION GRADE LINE ARRAY →

The IN.LINE™ series is a high performance, high fidelity sound reinforcement system which combines the superior sound reproduction qualities of a line array with the flexibility, versatility and affordability that installers require. IN.LINE™ line array modules are available in four models; three full range modules, and one low frequency module. All three full range modules are identical, except each generate a different horizontal coverage pattern; the N60 features a 60° horizontal coverage pattern, the N90 features a 90° pattern, and the N120 delivers 120° horizontal coverage pattern.

What makes the IN.LINE™ series unique, is that even though each full range module features a different horizontal coverage pattern, each IN.LINE™ module is engineered to operate in tangent with any other IN.LINE™ module, when deployed within the same "line array" column. All three modules can be combined in the same column to create seamless vertical coverage, (as determined by the size and curvature of the array) because all three full range modules have been designed to couple acoustically and form a single, undisturbed wavefront regardless of which horizontal patterns are chosen. Now, with the IN.LINE™ series, sound designers now have the ability to take advantage of the increased intelligibility, coherence and consistency of

coverage that a line array solution can offer, yet can still create the highly specialized coverage patterns that the majority of complex acoustic installations require. Because sound designers can "mix and match" horizontal dispersion patterns within the same array, coverage zones can be easily defined and highly targeted, reducing unwanted reflections and acoustic "overspill", all while maintaining a perfectly coherent vertical coverage pattern and highly consistent sound from the nearest listening position to the back of the room.

The series is completed by the NS1 low frequency module, which was designed to specifically complement the other three full range modules in applications where extended low frequency reinforcement is specified. Aesthetically, the NS1 integrates seamlessly and naturally with the other IN.LINE™ modules, creating a highly streamlined and professional appearance.

Finally, the IN.LINE™ series features a price point which is competitive enough to allow contractors and their customers to realistically make the transition from traditional loudspeaker clusters to a line array technology without jeopardizing the contractor's ability to win bids.

IN.LINE SERIES RECOMMENDED COMPANION PRODUCTS AND ACCESSORIES

- MCS2.6 Digital Systems Controller
- NB24 Bumper System
- SM72 Direct-Q™ 2-Way Stage Monitor System
- AC66 Compact 2-Way Full Range Under Balcony System

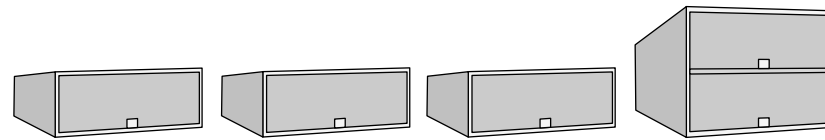

IN.LINE™ SERIES	N60 60° FULL RANGE MODULE	N90 90° FULL RANGE MODULE	N120 120° FULL RANGE MODULE	NS1 LOW FREQUENCY MODULE
FREQUENCY RESPONSE	60Hz - 19kHz (±3dB)	60Hz - 19kHz (±3dB)	60Hz - 19kHz (±3dB)	35Hz - 250Hz (±3dB)
SENSITIVITY				
LF (2.83v @1m)	97 dB SPL	97 dB SPL	97 dB SPL	99 dB SPL
HF (2.83v @1m)	107 dB SPL	106 dB SPL	105 dB SPL	n/a
POWER HANDLING				
LF	800w AES, 16Ω	800w AES, 16Ω	800w AES, 16Ω	(2) x 800w AES, 8Ω each
HF	120w AES, 16Ω	120w AES, 16Ω	120w AES, 16Ω	n/a
NOMINAL COVERAGE				
Horizontal	60°	90°	120°	n/a
Vertical	dependent on array size and array curvature.			
MAXIMUM SPL	132 dB SPL	132 dB SPL	132 dB SPL	133 dB SPL
COMPLEMENT				
LF	(2) x 8.8"	(2) x 8.8"	(2) x 8.8"	(2) x 15"
HF	(1) x 1"	(1) x 1"	(1) x 1"	n/a
PHYSICAL PROPERTIES				
Dimensions (inches)	27.3w x 10H ² x 7H ² x 18D	27.3w x 10H ² x 7H ² x 18D	27.3w x 10H ² x 7H ² x 18D	27.3w x 20.5H x 29.5D
Dimensions (centimeters)	69.4w x 26H ² x 17H ² x 46D	69.4w x 26H ² x 17H ² x 46D	69.4w x 26H ² x 17H ² x 46D	69.4w x 52H x 74.9D
Trapezoid Angle	5°	5°	5°	0°
Weight	62 lbs / 28 kgs	62 lbs / 28 kgs	62 lbs / 28 kgs	145 lbs / 65 kgs
Construction	5/8" Void Free Finland Birch	5/8" Void Free Finland Birch	5/8" Void Free Finland Birch	5/8" Void Free Finland Birch
Finish	ProCoat™, White or Raw	ProCoat™, White or Raw	ProCoat™, White or Raw	ProCoat™, White or Raw
APPLICATION DATA				
Design Factor	20 @ 7:1	20 @ 7:1	20 @ 7:1	12 @ 7:1
Vertical Splay	0° - 10° in 2° increments	0° - 10° in 2° increments	0° - 10° in 2° increments	0° - 10° in 2° increments
Connectors	NL4 & Terminal Strip	NL4 & Terminal Strip	NL4 & Terminal Strip	NL4 & Terminal Strip
Suspension	IN.LINE Integrated Rigging	IN.LINE Integrated Rigging	IN.LINE Integrated Rigging	IN.LINE Integrated Rigging

DIMENSIONAL ILLUSTRATIONS

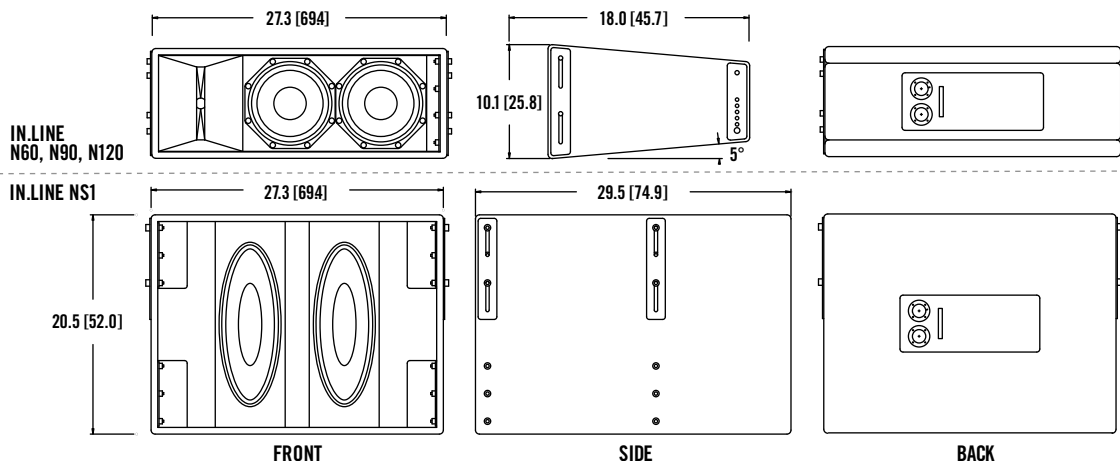

This loudspeaker series shall be (3) full range models of varying horizontal coverage patterns, each consisting of a two-way type configuration with two 8.8" low / mid frequency drivers mounted in a bass reflex enclosure and one 1" throat compression driver, and (1) model of matching low frequency module, consisting of two 15" low frequency transducers mounted in a coupled V configuration. The full range models' low frequency section shall contain two 8.8" drivers with a power handling capacity of 800 watts AES and shall have a sensitivity of 97dB SPL measured at 1 meter with 2.83 volts into a nominal 16Ω load. The high frequency section shall consist of one 1" exit compression driver and horn combination with a power handling capacity of 120 watts AES and a sensitivity of 107 (N60), 106 (N90) and 105 dB (N120) SPL measured at 1 meter with 2.83 volts into a nominal 16Ω load respectively. The combined loudspeaker system shall be capable of 129 dB SPL continuous and 135 dB SPL peak maximum output. The loudspeaker series shall have an effective operating range of 60 Hz to 19 kHz +/- 3 dB. The loudspeaker series shall offer Horizontal coverage angles of 60°, 90° and 120° respectively. Individual full range enclosures shall weigh a total of 62 lbs. and shall measure 27.3

inches wide, 10 inches tall (7 inches at rear) and 18 inches in depth. The enclosure top and bottom shall be angled at 5° from front to back forming a trapezoidal shape. The low frequency module shall contain two 15" drivers with a power handling capacity of 800 watts AES each and shall have a sensitivity of 99dB SPL measured at 1 meter with 2.83 volts. Individual subwoofer enclosures shall weigh a total of 80 lbs. and shall measure 27.3 inches wide, 20.5 inches tall and 29.5 inches in depth. Each enclosure shall be made of 12-ply void-free hardwood. Each loudspeaker shall have an integrated rigging system which will allow 0° - 10° of splay per module, allowing for the formation of vertical arrays up to 24 modules deep. Electrical connections shall be made via terminal strips or NL4 connectors. The system shall employ Frequency Dependent Adaptive Steering™ technology to achieve a high degree of directivity, and as such shall behave as an acoustic line array when arrayed in accordance to the systems design specifications, and shall exhibit only -3dB decrease of measurable SPL per doubling of distance. These loudspeakers shall be the McCauley IN.LINE™ Installation-Grade Line Array Series.

ARCHITECTURAL SPECIFICATIONS